

ESP-LXD Controller

ESP-LX Series Controllers

The popular Rain Bird ESP-LX Series commercial controller line now includes a two-wire controller. The ESP-LXD controller has been designed to maintain the look, feel and ease of programming of the ESP-LX Series controllers but with an interface to a two-wire path for decoder-based irrigation. The ESP-LXD controller provides flow sensing and management and 50 station capacity expandable to 200 stations.

Applications

The ESP-LXD provides flexible features and modular options that make the controller ideal for a wide variety of applications including light-commercial, commercial and industrial irrigation systems. Options include a metal case and pedestal, ET Manager Smart Cartridge, IQ v2.0 Central Control Communication Cartridges, and the PBC-LXD Programming Backup Cartridge. These options can easily be installed with the initial controller installation or when needed in the future.

Easy to Use

The ESP-LXD Controller utilizes the Rain Bird ESP Extra-Simple Programming user interface. The dial, switches, and buttons interface, which Rain Bird first introduced in the early 1990s, are easy to learn and use and have become a standard controller interface for the irrigation industry. The large LCD display incorporates softkey text labels for the button functions rather than dedicated buttons.

Multiple language support allows the end user or maintenance personnel to interface with the controller in his or her primary language. User-selectable languages include English, Spanish, French, German, Italian and Portuguese. Date, time and unit formats are also user-configurable.

Easy to Install

The ESP-LXD Controller has a spacious case and eight lugs for up to four two-wire paths making installation fast and easy. Multiple size wiring knockouts are provided on the bottom and back side of the case to adapt to a wide variety of wiring applications. The door and front panel are removable so the case can be easily mounted to the wall.

Controller Features

- Plastic, UV-resistant, locking, wall-mount case
- Uses the same decoder hardware as MDC, MDC2 and SiteControl
- Supported decoders: FD-101TURF, FD-102TURF, FD-202TURF, FD-401TURF, FD-601TURF
- Also supports SD-210TURF sensor decoders (flow sensing and weather sensor support) and LSP-1 line surge protectors (one per 500 feet of two-wire path required)
- 50-station capability standard expandable to 200 stations with optional ESPLXD-SM75 modules
- Four sensor inputs (one wired plus up to three decoder-managed) with override switch
- Program backup and barcode decoder address entry with the optional PBC-LXD
- Six user-selectable languages
- Removable front panel is programmable under battery power
- Optional LXMM metal case and LXMMPED metal pedestal
- Central Control capable with Rain Bird IQ v2.0 Communications Cartridges and software

Water Management Features

- Learn Flow utility and flow usage totalizer
- FloWatch™ protection for high and low flow conditions with user-defined reactions
- FloManager™ manages hydraulic demand, making full use of available water to shorten total watering time
- Programmable SimulStations™ allow up to 8 stations to operate at the same time
- Cycle+Soak™ by station
- Rain Delay
- 365-Day Calendar Day Off
- Programmable Station Delay by program
- Up to 5 Normally Open or Normally Closed Master Valves programmable by station
- Up to 4 Weather Sensors programmable by station to prevent or pause watering
- Program & Monthly Seasonal Adjust

Diagnostic Features

- Alarm light with external case lens
- Electronic diagnostic circuit breaker
- Program summary and review
- Variable test program
- Two-wire diagnostics to simplify and expedite troubleshooting



Operating Specifications

- Station timing: 0 min to 12 hrs
- Seasonal Adjust: 0% to 300% (16 hrs maximum station run time)
- 4 independent programs (ABCD); ABCD programs can overlap
- 8 start times per program
- Program Day Cycles include Custom days of the week, Odd, Odd no 31st, Even, and Cyclical dates
- Manual station, program, test program

Certifications

- UL, CUL, CE, CSA, C-Tick, FCC Part 15

Electrical Specifications

- Input required: 120 VAC ± 10%, 60Hz (International models: 230 VAC ± 10%, 50Hz; Australian Models: 240 VAC ± 10%, 50Hz)
- Power back-up: Lithium coin-cell battery maintains time and date while nonvolatile memory maintains programs
- Multi-valve station capacity: up to 2 solenoid valves per station; simultaneous operation of up to eight solenoids and/or master valves
- Rain Bird residential valves (DV and JTV series) are not compatible with ESP-LXD decoders. Use Rain Bird commercial valves (PGA, PEB, GB, EFB-CP and BPE series).

Dimensions (W x H x D)

- 14.32" x 12.69" x 5.50" (36.4 x 32.2 x 14.0 cm)

How To Specify

Controller ESP-LXD

Models
ESP-LXD: 120v Outdoor
IESP-LXD: 230v Intl
IESPLXDEU: 230V (EU)
IESP-LXDA: 240V (AUS)

Modules & Cartridges ESPLXD-SM75

Models
75-station module
PBC-LXD: Program Backup Cartridge

ESPLXD-M50 Module (included)

The ESP-LXD is a controller in a cabinet with locking door manufactured with UV-resistant plastics for outdoor use. Included with every ESP-LXD is the ESPLXD-M50 module, a “double-wide” module which snaps onto two adjacent mounts on the controller backplane. The ESPLXD-M50 module includes the lugs for attachment of the two-wire path cables.

Flow Smart software is included with the ESPLXD-M50 module. This includes FloWatch™ featuring a Learn Flow utility, flow usage totalizer, protection for high and low flow conditions with user-defined reactions, FloManager™ for managing hydraulic demand, making full use of available water to shorten total watering time.



ESPLXD-M50 Module

Optional Accessories for the ESP-LXD Controller

ESPLXD-SM75 Station Modules

The ESP-LXD controller is capable of managing up to 50 stations right out of the box. If additional station capacity is needed, it can be added by attaching 1 -2 ESPLXD-SM75 station modules, each of which adds an additional 75 stations up to a maximum of 200 stations, onto the controller backplane.

Station Configuration

The desired station capacity can be achieved by combining the following modules:

# Stations	ESPLXD-SM75 Modules
1 – 50	0
51 – 125	1
126 – 200	2



ESPLXD-SM75 Module

PBC-LXD Cartridge

The Program Backup Cartridge installs into the cartridge bay in the back of the controller front panel and adds Backup and Restore and barcode Decoder Address Entry capability. The backup feature allows 8 full backups of all programming and decoder addresses in an ESP-LXD controller. Decoder address entry allows you to attach a barcode scanning pen (sold separately) and scan the peel-off barcode labels from the Programming Chart included with the controller to significantly reduce installation and setup time. A barcode scanning pen, not included with the cartridge, is required for barcode scanning; Rain Bird recommends the Unitech MS100-2 pen with 9-pin female serial connector.



PBC-LXD Cartridge

Metal Case & Pedestal

The ESP-LXD Controller has an optional LXMM Metal Wall-Mount Case and LXMM-PED Metal Pedestal. The ESP-LXD standard plastic case field installs into the LXMM and can be wall-mounted or attached to the LXMPED for free-standing controller applications. The LXMM and LXMM-PED use powder-coated steel for years of rust-free operation.



LXMM Metal Case

LXMPED Metal Pedestal

IQ™ v2.0 Network Communication Cartridges

IQ NCC Network Communication Cartridges upgrade ESP-LX Series standalone controllers to IQ satellite controllers capable of being controlled by the IQ v2.0 Central Control software. The NCC cartridges snap into the back of the controller front panel and provide a communication link between the IQ central computer and the remote site controllers. ESP-LXD can use any of the five available NCC cartridges:

- IQ NCC-PH: Phone
- IQ NCC-WF: Wi-Fi
- IQ NCC-GP: GPRS/Cellular
- IQ NCC-RS: RS232
- IQ NCC-EN: Ethernet



IQ NCC-GP Communication Cartridge

Weather Sensors

The ESP-LXD supports up to 4 weather sensors, one local and up to three additional on the two-wire path interfaced with SD-210 sensor decoders. Supported Rain Bird sensors include the RSD wired rain sensor, the WR2-RC wireless rain sensor, the WR2-RFC wireless rain/freeze sensor and the ANEMOMETER wind sensor (the Rain Bird 3002 Pulse Transmitter is required for use of the ANEMOMETER). Soil moisture sensors that provide a normally closed switch interface are also supported.



WR2-RFC Wireless Rain/Freeze Sensor

ET Manager™ Smart Cartridge

The ESP-LXD Controller can be upgraded to a weather adjusted Smart controller with the addition of the ETC-LX ET Manager Cartridge. The ET Manager upgrade kit includes a cartridge that installs in the back of the controller front panel and an antenna that installs through a knock-out in the top of the controller case. The ETM receiver collects hourly weather station sensor data via a wireless paging signal. This data is used to calculate an Evapotranspiration (ET) value and irrigation is automatically adjusted to apply only the amount of water needed.

ETC-LX
ET Manager
Smart Cartridge



Decoders and the Two-Wire Path

The Two-Wire Path

Decoder-based control systems such as the ESP-LXD interface to valves and other irrigation hardware through decoders along a two-wire path. Although “loop” pattern two-wire installations allow longer wire paths, the “star” pattern is more commonly used. When 14-2 Maxi cable is used, the ESP-LXD supports a wire path of up to 1.65 miles (2.66 km) for “star” pattern installations and up to 6.61 miles (10.63 km) for “loop” installations.

Protection against water intrusion is essential for two-wire installations. Designed to be impervious to water intrusion, Rain Bird Maxi-Cable™ (double-jacketed) is required for two-wire path installations. Proper splicing technique for all splices along the two-wire path, for splicing decoders to the two-wire path, and for splicing decoders to valves and other hardware is also critical. Splice kits such as the Rain Bird DB (direct burial) connectors should be used.

Decoders

Decoders are installed along the two-wire path to interface to valves and other hardware. The ESP-LXD supports Field Decoders, for control of station valves and master valves, and Sensor Decoders, for interface with flow and weather sensors. All Rain Bird decoders have unique five digit addresses to allow the controller to manage a particular device, such as a valve.

Sensor Decoders

Rain Bird also offers a SD210TURF sensor decoder to interface to weather sensors or flow sensors. When a SD-210 is wired to a weather sensor along the two-wire path, it provides constant real-time monitoring of the weather sensor status. A SD-210 wired to a flow sensor monitors the current flow rate at a flow monitor by sending pulses to the controller.

Surge Protection

Proper grounding and surge protection is essential for two-wire installations. A two-wire path must be surge protected and grounded every 500 feet (150 meters) or every 8 decoders, whichever is smaller. The LSP1TURF Line Surge Protector is used for this purpose, but the FD-401 and FD-601 field decoders include line surge protection so LSP-1s are unnecessary when grounded FD-401 and FD-601 field decoders are used. Since LSP-1 Line Surge Protectors are used for surge protection only, they do not have decoder addresses.

Field Decoders

Field decoders are used to open and close station valves and master valves used for irrigation and are the most common decoders used in most two-wire installations. Rain Bird offers five field decoder models, including the FD-101 which controls a single valve with a single address and four other models capable of controlling multiple valves:

Decoder Model	Number of Addresses Per Decoder	Maximum Number Of Solenoids Per Address	Maximum Addresses Operating At Once
FD101TURF	1	1	1
FD102TURF	1	2	1
FD202TURF	2	2	2
FD401TURF*	4	1	4
FD601TURF*	6	1	4

* Decoder includes Line Surge Protection.

The ESP-LXD controller supports up to 5 Master Valves, and both Normally Open Master Valves and Normally Closed Master Valves are supported.

The ESP-LXD also supports the use of pumps. These are set up and managed by the controller in the same way as Master Valves, except that the field decoder is wired to a pump start relay instead of to a Master Valve.

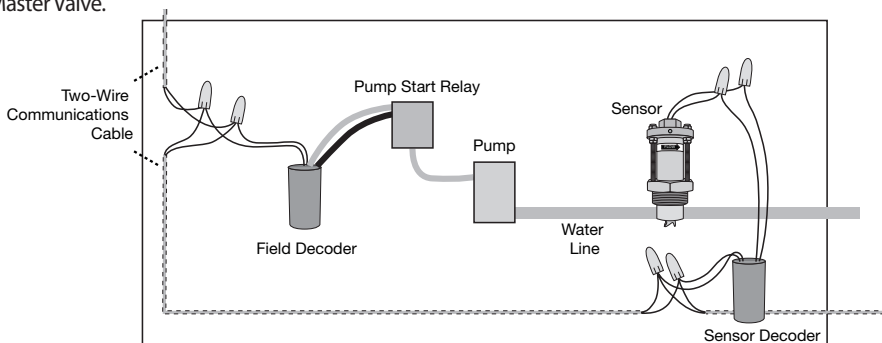

Rain Bird recommends using the FD-101 field decoder for most pump start relays and a FD-102 for larger pumps (3/4 HP and greater).

LSP1TURF
Line Surge
Protector



SD210TURF
Sensor
Decoder



Specifications

The ESP-LXD Controller shall be of a hybrid type that combines electro-mechanical and micro-electronic circuitry capable of fully automatic or manual operation. The controller shall be housed in a wall-mountable, weather-resistant plastic cabinet with a key-locking cabinet door suitable for either indoor or outdoor installation. The controller shall have the ability to be programmed and operated in any one of six languages: English, Spanish, French, German, Italian, & Portuguese. The display shall show programming options and operating instructions in the chosen language without altering the programming or operation information.

The controller shall have a base station capacity of 50 stations with two additional expansion slots capable of receiving ESPLXD-SM75 station modules to create a controller capacity of up to 200 stations. All stations shall have the capability of independently obeying or ignoring any weather sensor as well as using or not using the master valves. Station timing shall be from 0 minutes to 12 hours. The controller shall have a Seasonal Adjustment by program which adjusts the station run time from 0 to 300% in 1% increments. The controller shall also have a Monthly Seasonal Adjustment of 0 to 300% by month. Station timing with Seasonal Adjustment shall be from 1 second to 16 hours.

The controller shall have 4 separate and independent programs which can have different start times, start day cycles, and station run times. Each program shall have up to 8 start times per day for a total of 32 possible start times per day. The 4 programs shall be allowed to overlap operation based on user defined settings which control the number of simultaneous stations per program and total for the

controller. The controller shall allow up to 8 valves to operate simultaneously per program and total for the controller including the master valves.

The controller shall have a 365-day calendar with Permanent Day Off feature that allows a day(s) of the week to be turned off on any user selected program day cycle. (Custom, Even, Odd, Odd31, & Cyclical). Days set to Permanent Day Off shall override the normal repeating schedule and not water on the specified day(s) of the week. The controller shall also have a Calendar Day Off feature allowing the user to select up to 5 dates up to 365-days in the future when the controller shall not start programs. The controller shall incorporate a Rain Delay feature allowing the user to set the number of days the controller should remain off before automatically returning to the auto mode.

The controller shall have Cycle+Soak water management software which is capable of operating each station for a maximum cycle time and a minimum soak time to reduce water run-off. The maximum cycle time shall not be extended by Seasonal Adjustment.

The controller shall incorporate a FloManager feature providing real-time flow, power, and station management. FloManager shall manage the number of stations operating at any point in time based on water source capacity, station flow rate, number of valves per station; user-defined simultaneous stations per program and for the controller. The controller shall provide station priorities to determine the order in which stations shall operate. The controller shall ignore the station number and instead operate the highest priority stations first and the lower priority stations last.

The controller shall offer Water Windows for each program. This function sets the allowed start and stop time where watering is allowed. If the watering cannot be completed by the time the Water Window closes, the stations with remaining run time are paused and watering automatically resumes when the Water Window opens the next time.

The controller shall include an integrated Flow Smart Module with flow sensing functionality. The Flow Smart Module shall accept sensor decoder input from 1 - 5 flow sensors with no flow scaling device required.

A FloWatch Learn Flow Utility which learns the normal flow rate of each station shall be included. Each time a station runs FloWatch compares the current real-time flow rate to the learned rate and takes user-defined actions if high flow, low flow, or no flow is detected. FloWatch shall automatically determine the location of the flow problem and isolate the problem by turning off the affected station(s) or master valve(s). FloWatch shall be compatible with both normally closed and open master valves. A Manual Master Valve Water Window shall be provided to coordinate daytime manual watering with the flow sensing. This Water Window shall offer programmable days of the week and manual watering additional flow rate.

Rain Bird Corporation

6991 E. Southpoint Road
Tucson, AZ 85756
Phone: (520) 741-6100
Fax: (520) 741-6522

Rain Bird Technical Services

(800) RAINBIRD (1-800-724-6247)
(U.S. and Canada)

Rain Bird Corporation

970 West Sierra Madre Avenue
Azusa, CA 91702
Phone: (626) 812-3400
Fax: (626) 812-3411

Specification Hotline

800-458-3005 (U.S. and Canada)

Rain Bird International, Inc.

1000 West Sierra Madre Ave.
Azusa, CA 91702
Phone: (626) 963-9311
Fax: (626) 852-7343

The Intelligent Use of Water™
www.rainbird.com