



FABRICATION AND INSTALLATION INSTRUCTIONS FOR SUPPORT MULLIONS

These installation instructions apply to the fabrication and construction of generic support mullions. Support mullions are necessary whenever fire dampers are installed into an opening that is larger than the largest UL rated size for that damper. The mullions allow construction of a fire barrier that is larger than the maximum available size.

The opening must not exceed 120" high, but can be any width provided a vertical support mullion is used a maximum of every 120".

To properly use support mullions they must be fabricated and installed according to these instructions.

This generic support mullion is permitted by UL to only be used in static systems. A static system is one in which the fan shuts down in the event of a fire or smoke alarm.

Application

Generic steel mullions can be used to separate vertically mounted galvanized steel fire dampers in wall openings larger than the UL permitted multiple damper assembly size. Mullions can either be used vertically, horizontally or both to split up a vertical wall opening requiring use of a damper having a 1-1/2 hour fire resistance rating. Maximum mullion span is 120" plus expansion allowance when used either horizontally or vertically.

Sleeves are to be around each damper assembly. Mullions are not intended to be in the airstream, (i.e. exposed to flow) or to be a part of the ductwork.

Wall Opening

Steel mullions are intended for use in a concrete block or solid concrete wall.

Hollow concrete blocks are to be filled with concrete (minimum 3500 psi) to permit proper mullion anchoring.

Wall thickness is to be 7" minimum, 12" maximum.

SUPPORT MULLIONS - 02-05 (SUPPORTMULLIONS)

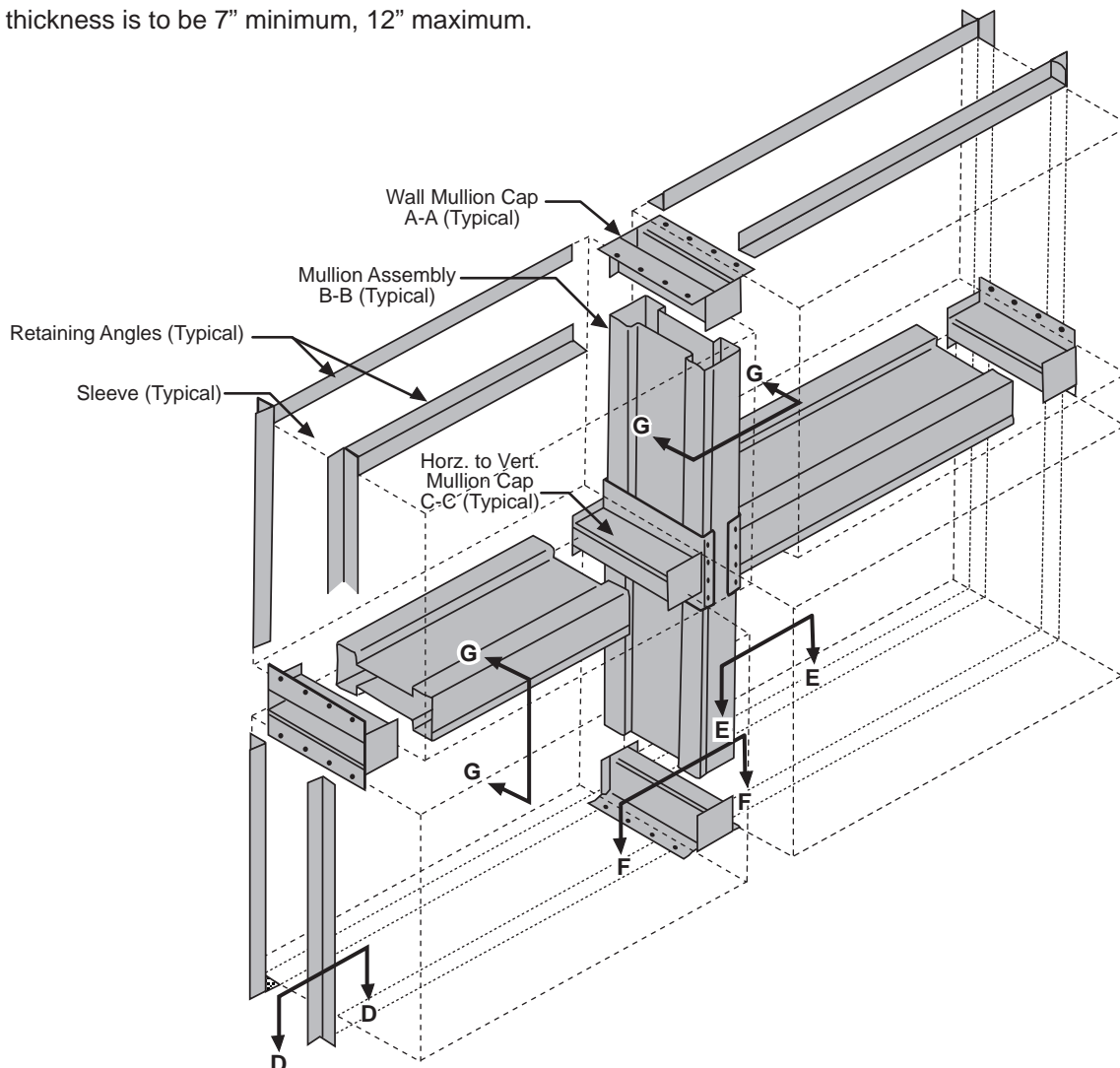

© 1999 NCA Manufacturing

Support mullion assemblies consist of three basic parts: the wall mullion cap, the horizontal to vertical mullion cap and the mullion sections. Determine the number of each piece required to complete the installation.

Table 1
Dimensional Information

Opening Width/Height	D	H
12	11-1/2"	3-1/4"
24	23-1/2"	3-3/8"
36	33-3/8"	3-1/2"
48	47-1/4"	3-5/8"
60	59-1/8"	3-3/4"
72	71"	3-7/8"
84	82-7/8"	4"
96	94-3/4"	4-1/8"
108	106-3/4"	4-1/4"
120	118-3/4"	4-3/8"

E = Wall Thickness - 1/2"
F = Wall Thickness + 1/4"

Fabrication of Wall Mullion Caps (Fig. A-A)

Wall mullion caps must be constructed from 12 ga. steel with a minimum yield strength of 42,000 psi.

1. Fabricate the formed section as shown to right.
2. Shear the cap end plate to required dimensions.
3. Weld the cap end plates to the formed section with 1/8" fillet welds completely around the top edges of the formed section.
4. Drill and countersink 8 holes (4 on each side for 1/4-20 flat head machine screws.

Detail A-A

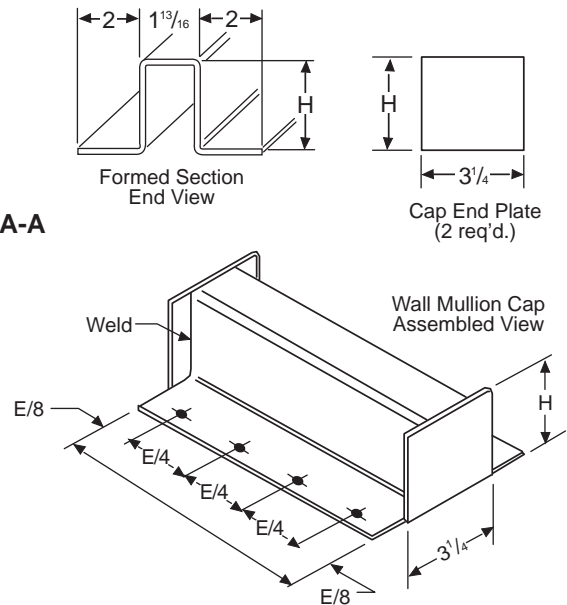

Formed Section View (2 req'd.)

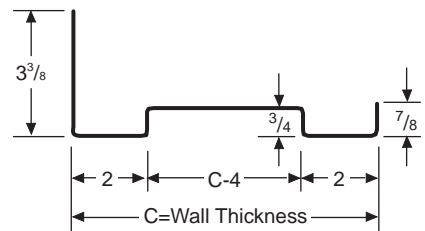

Detail B-B

Assembled View

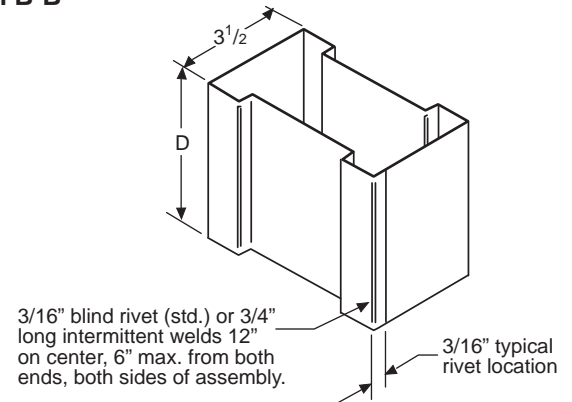

Fabrication of Mullion Sections (Fig. B-B)

Mullions must be constructed from 16 ga. steel with a minimum yield strength of 42,000 psi.

Important: The "D" dimension shown has been calculated to include the necessary clearances required for thermal expansion in the mullions. The values can be found using the wall opening dimensions and tables on this page.

1. Form two identical pieces of mullion section as shown.
2. Connect the two mullion sections together. Use 3/16" steel blind rivets or 3/4" long intermittent welds 12" on center and a 6" maximum from both ends.

Important: Both sides of the mullion piece should be fastened using the method described above.

Fabrication of Horizontal to Vertical Mullion Caps (Fig. C-C)

Horizontal to vertical mullion caps must be constructed from 12 ga. steel with a minimum yield strength of 42,000 psi. Important: The H, E and F dimensions shown have been calculated to provide the correct performance. The values can be found by using the wall opening dimensions and the tables on page 2.

1. Form the horizontal mullion channel as shown.
2. Drill 12, 3/16" dia. holes into the horizontal mullion channel using the dimensions shown.
3. Form the center channel as shown.
NOTE: If the center channel is to be made from two pieces, weld them together with an 1/8" fillet weld.
4. Shear the end plates to the dimensions required.
5. Weld the end plates to the center channel with 1/8" fillet welds completely around the top edges of the center section.

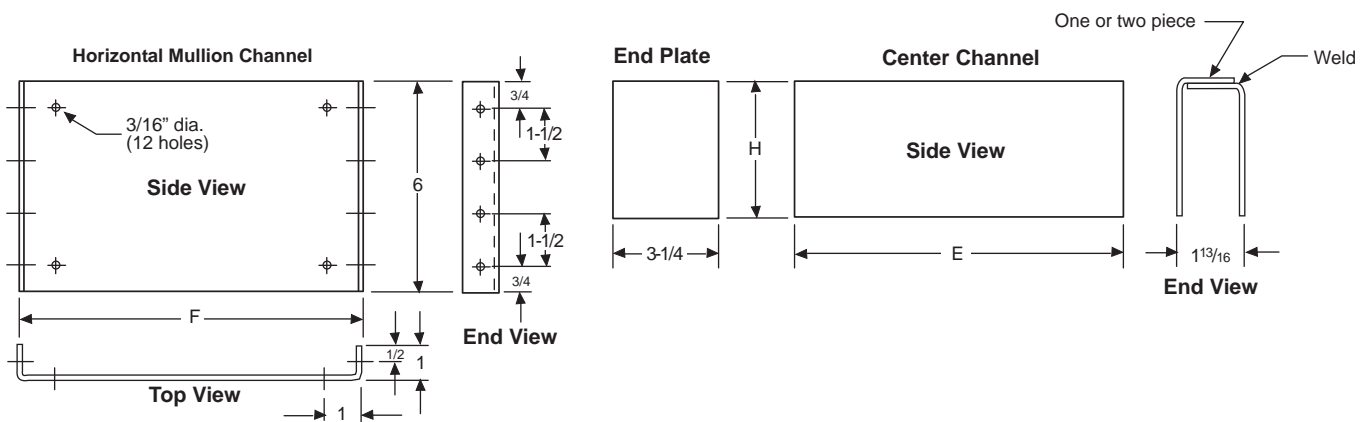

Detail C-C

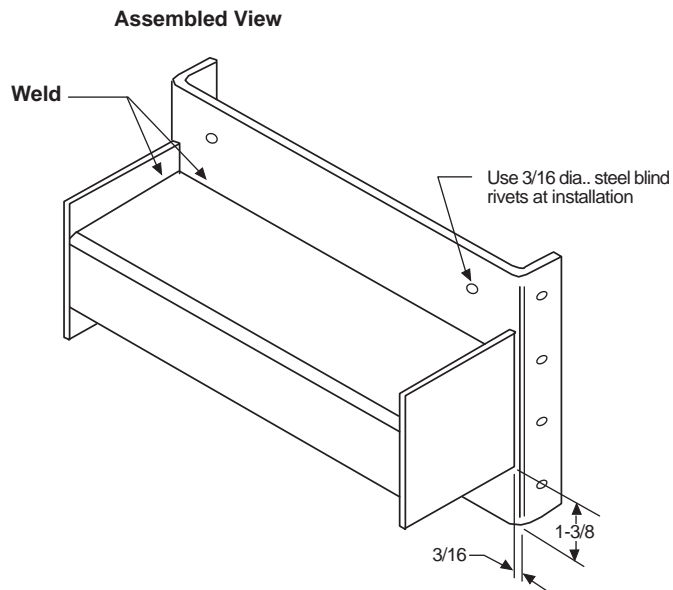

SUPPORT MULLIONS - 02-05 (SUPPORTMULLIONS)

Mullion Installation

Before the fire dampers are installed into the wall the mullions must first be anchored into the wall. The fire dampers may then be installed into the mullion assembly.

To correctly attach the mullions to the wall follow these steps:

1. Anchor wall mullion caps to wall using 1/4-20 x 5/16" long flat head steel bolts and 3/8" diameter by 1" long concrete expansion anchors (Hilti). If steel lintels are present, use two 1" long welds on each side of mullion caps. Note: End caps must be inserted into the ends of the mullions before they are anchored to the wall.
2. Anchor horizontal mullion caps to vertical mullion caps with 3/16" diameter steel blind rivets in 12 places. Note: Mullion caps must be inserted into the ends of the mullions before they are anchored to the vertical mullions or wall.

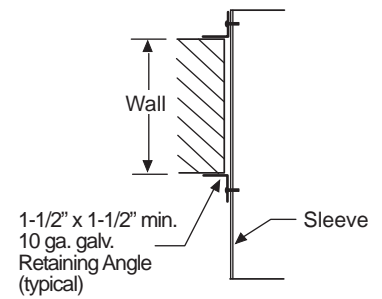

Detail D-D

Fire Damper Installation

Galvanized steel fire dampers must be UL classified for 1-1/2 hour fire resistance. They must be installed in galvanized steel sleeves and be retained by minimum 1-1/2" x 1-1/2", 16 ga. retaining angles on each side of the wall. Retaining angles must overlap mullions or wall by 1" minimum. Fasten to sleeve using 1/4" dia. bolts, 3/16" steel rivets, welding, or #10 sheet metal screws. All must be attached 6" on centers, 2" maximum from corners. Do not fasten retaining angles to the wall or mullions. Mullions must be free to float.

Total expansion clearance between sleeve and wall/mullion of 1/8" per foot of wall opening or mullion span should be allowed. Maximum clearance is 1-1/4".

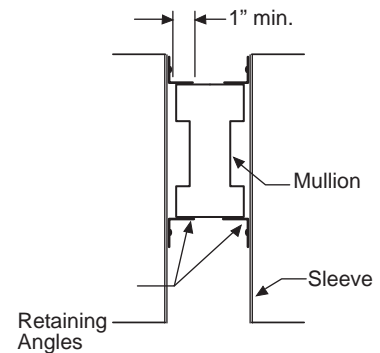

Detail E-E

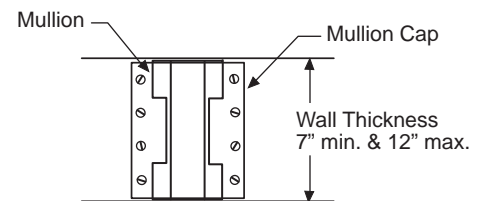

Detail F-F

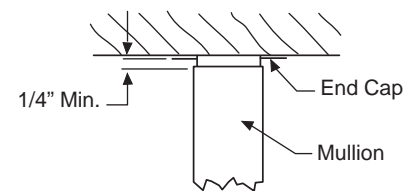

Detail G-G

SUPPORT MULLIONS - 02-05 (SUPPORT MULLIONS)

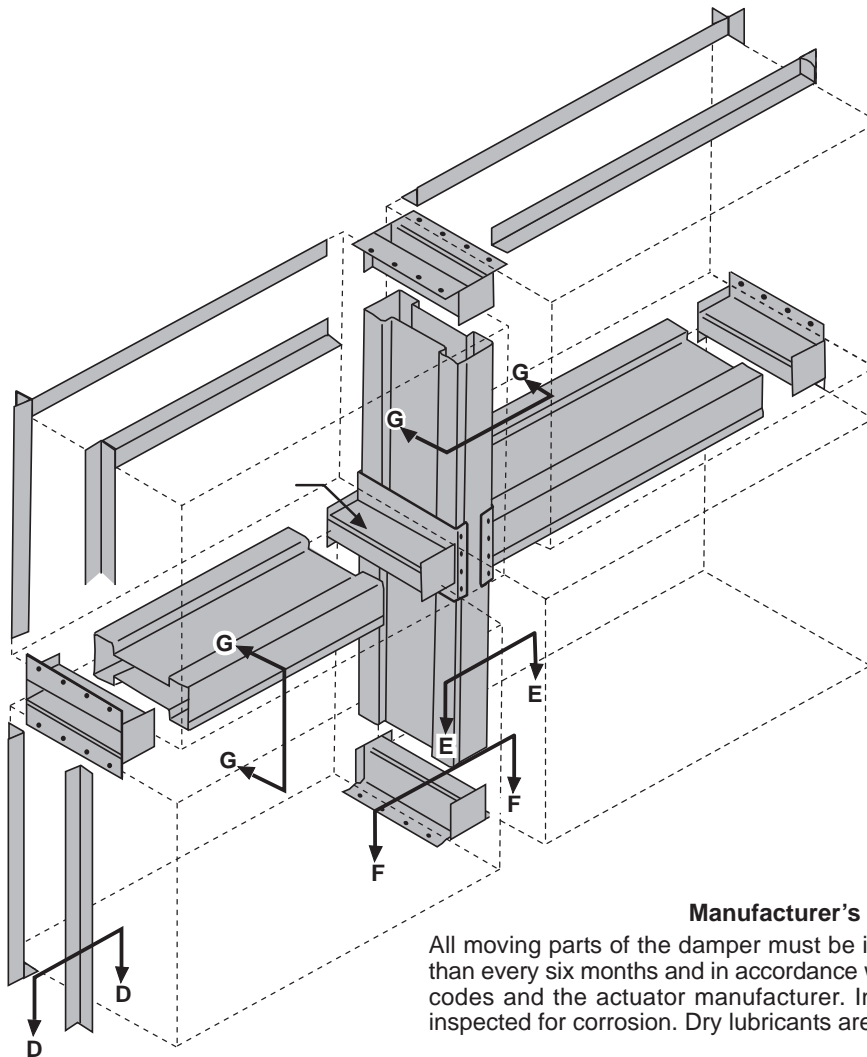

Manufacturer's Recommendations

All moving parts of the damper must be inspected and cycled at intervals not greater than every six months and in accordance with the latest edition of NFPA 90A, 92A, local codes and the actuator manufacturer. In addition, fuse links shall be removed and inspected for corrosion. Dry lubricants are recommended.