

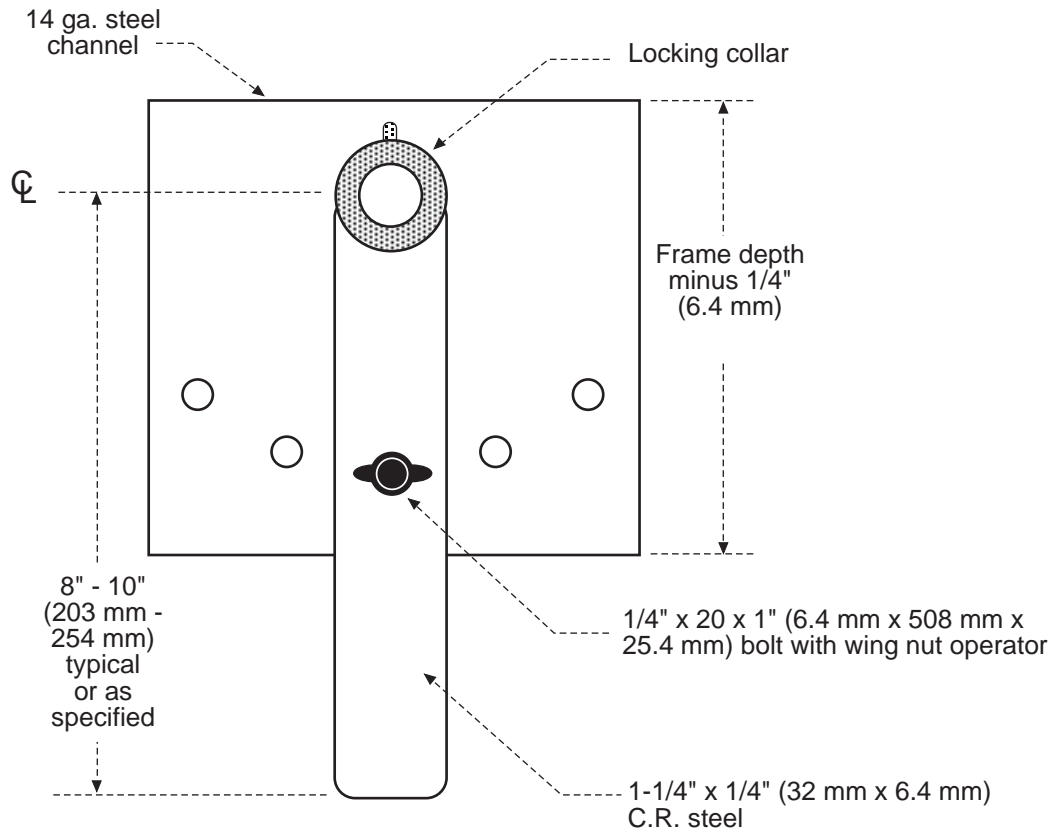

# HEAVY DUTY LOCKING QUADRANT

## Plan View (not to scale)



## Side View (not to scale)

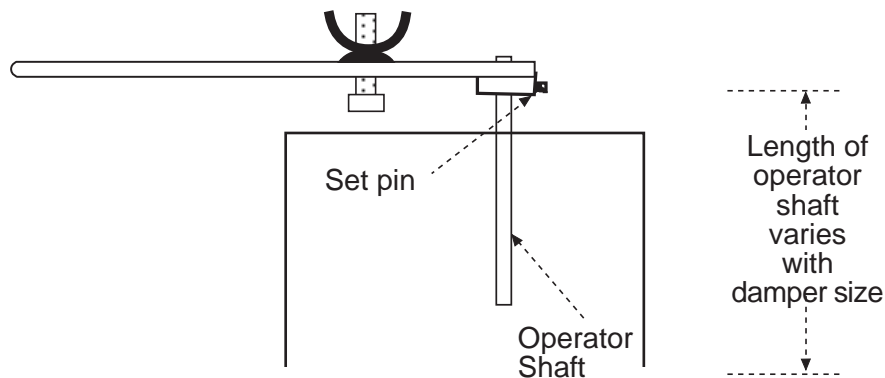

HEAVY DUTY LOCKING QUADRANT - 02-05

Specifications are correct at time of printing. However, as part of our 'continuous improvement program,' we reserve the right to make further improvements without notice.

All products made by members of S.M.W.I.A. Local #30

© 1999 NCA Manufacturing

Project:

Contractor:

Location:

Address:

Architect:

P.O. Number:

Engineer:

Date: