

ANGLE 582 BRONZE

300 lb. SWP-600 lb. WOG† • General Service
Bronze Regrinding Disc • Union Bonnet • Gland Packed • Threaded Ends

Disc and stem integral on 1/8" through 1/2".

SPECIFICATIONS

582	Conforms to: MSS SP-80. Type 1, Class 300, Threaded Ends.
-----	---

MATERIAL LIST

NO.	PART	MATERIAL	SPECIFICATION
1	Body	Bronze	ASTM B 61
2	Bonnet	Bronze	ASTM B 61
3	Disc	Bronze	ASTM B 61
4	Stem	Bronze	ASTM B 61
5	Union Bonnet Nut	Bronze	ASTM B 61
6	Packing	Non-Asbestos	Commercial
7	Gland	Bronze	ASTM B 16
8	Packing Nut	Bronze	Commercial
9	Handwheel	Mall. Iron	Commercial
10	Identification Plate	Aluminum	Commercial
11	Handwheel Nut	Bronze	Commercial
12	Disc Ring	Bronze	Commercial

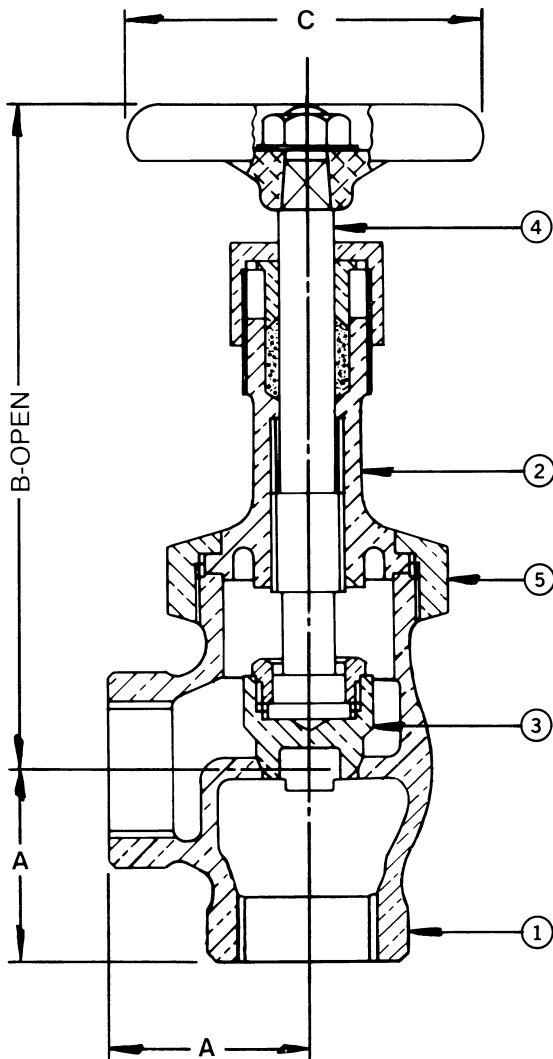

DIMENSIONS - INCHES / MILLIMETERS

Units	Size	A	B	C
Inches	1/4	1 1/16	4	2 1/4
MM	6.35	27.00	101.60	57.15
Inches	3/8	1 3/16	4	2 1/4
MM	9.53	30.18	101.60	57.15
Inches	1/2	1 1/4	4 1/2	2 1/2
MM	12.70	31.75	114.30	63.50
Inches	3/4	1 1/2	5 3/16	2 3/4
MM	19.05	38.10	131.78	69.85
Inches	1	1 3/4	6 3/8	3 1/4
MM	25.40	44.45	161.93	82.55
Inches	1 1/4	2 1/16	6 7/8	3 3/4
MM	31.75	52.40	174.63	95.25
Inches	1 1/2	2 1/4	7 1/2	4 1/4
MM	38.10	57.15	190.50	107.95
Inches	2	2 3/4	8 3/4	4 3/4
MM	50.80	69.85	222.25	120.65

† Non-Shock

INNOVATION IN EVERY VALVE



MILWAUKEE VALVE

The information presented on this sheet is correct at the time of publication. Milwaukee Valve reserves the right to change design, and/or material specifications without notice. For the most current information access www.milwaukeevalve.com

www.milwaukeevalve.com