

GLOBE 572 BRONZE

300 lb. SWP-600 lb. WOG† • General Service
Bronze Regrinding Disc • Union Bonnet • Gland Packed • Threaded Ends

Disc and stem integral on 1/8" through 1/2".

SPECIFICATIONS

572	Conforms to: MSS SP-80. Type 1, Class 300, Threaded Ends.
-----	--

MATERIAL LIST

NO.	PART	MATERIAL	SPECIFICATION
1	Body	Bronze	ASTM B 61
2	Bonnet	Bronze	ASTM B 61
3	Disc	Bronze	ASTM B 61
4	Stem	Bronze	ASTM B 61
5	Union Bonnet Nut	Bronze	ASTM B 61
6	Packing	Non-Asbestos	Commercial
7	Gland	Bronze	ASTM B 16
8	Packing Nut	Bronze	Commercial
9	Handwheel	Mall. Iron	Commercial
10	Identification Plate	Aluminum	Commercial
11	Handwheel Nut	Bronze	Commercial
12	Disc Ring	Bronze	Commercial

DIMENSIONS - INCHES / MILLIMETERS

Units	Size	A	B	C
Inches	1/4	2 1/16	4	2 1/4
MM	6.35	52.40	101.60	57.15
Inches	3/8	2 1/16	4	2 1/4
MM	9.53	52.40	101.60	57.15
Inches	1/2	2 7/16	4 1/2	2 1/2
MM	12.70	61.93	114.30	63.50
Inches	3/4	2 15/16	5 3/16	2 3/4
MM	19.05	74.63	131.78	69.85
Inches	1	3 3/4	6 3/8	3 1/4
MM	25.40	95.25	161.93	82.55
Inches	1 1/4	4 1/4	7	3 3/4
MM	31.75	107.95	177.80	95.25
Inches	1 1/2	4 3/4	7 3/4	4 1/4
MM	38.10	120.65	196.85	107.95
Inches	2	5 3/4	10	4 3/4
MM	50.80	146.05	254.00	120.65

† Non-Shock

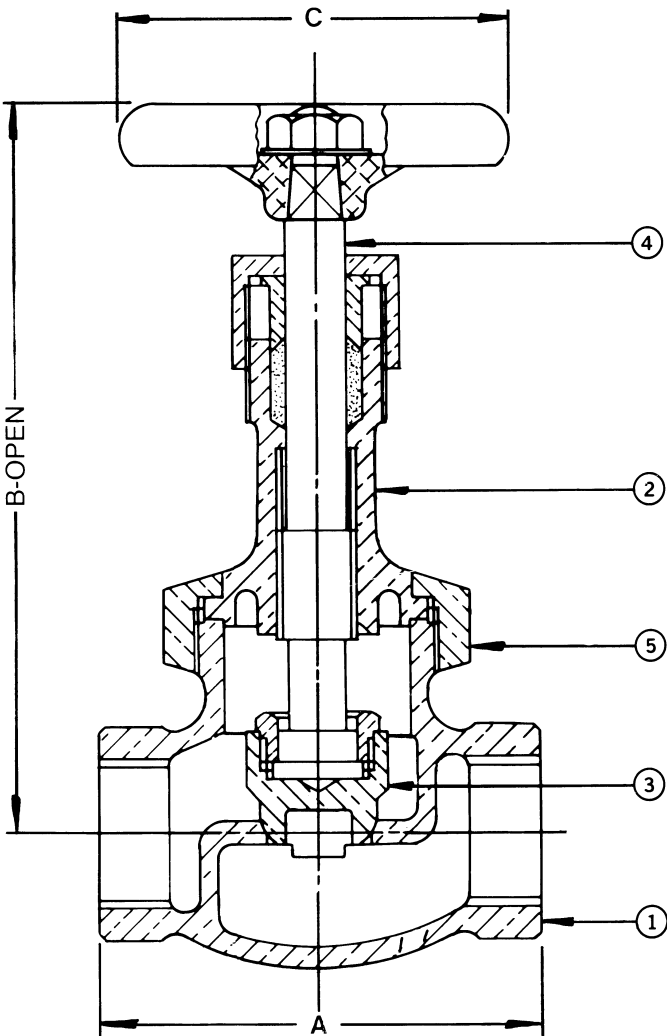

INNOVATION IN EVERY VALVE



MILWAUKEE VALVE