

ANGLE 504 BRONZE

125 lb. SWP-200 lb. WOG† • Plumbing and Heating
Bronze Disc • Threaded Bonnet • Threaded Ends

1/4" to 1/2" sizes have the disc integral with the stem and have no disc ring.

SPECIFICATIONS

504	Conforms to: MSS SP-80. Type 1, Class 125, Threaded Ends.
-----	---

MATERIAL LIST

NO.	PART	MATERIAL	SPECIFICATION
1	Body	Bronze	ASTM B 62
2	Bonnet	Bronze	ASTM B 62
3	Disc	Bronze	ASTM B 62
4	Stem	Bronze	ASTM B 62
5	Disc Ring	Bronze	ASTM B 16 3/4" to 2" ASTM B 62 2 1/2" and 3"
6	Packing	Non-Asbestos	Commercial
7	Packing Nut	Bronze	Commercial
8	Handwheel	Mall. Iron	Commercial
9	Identification Plate	Aluminum	Commercial
10	Handwheel Nut	Bronze	Commercial
11	Gland (not shown)	Bronze	ASTM B 16 2 1/2" and 3" only

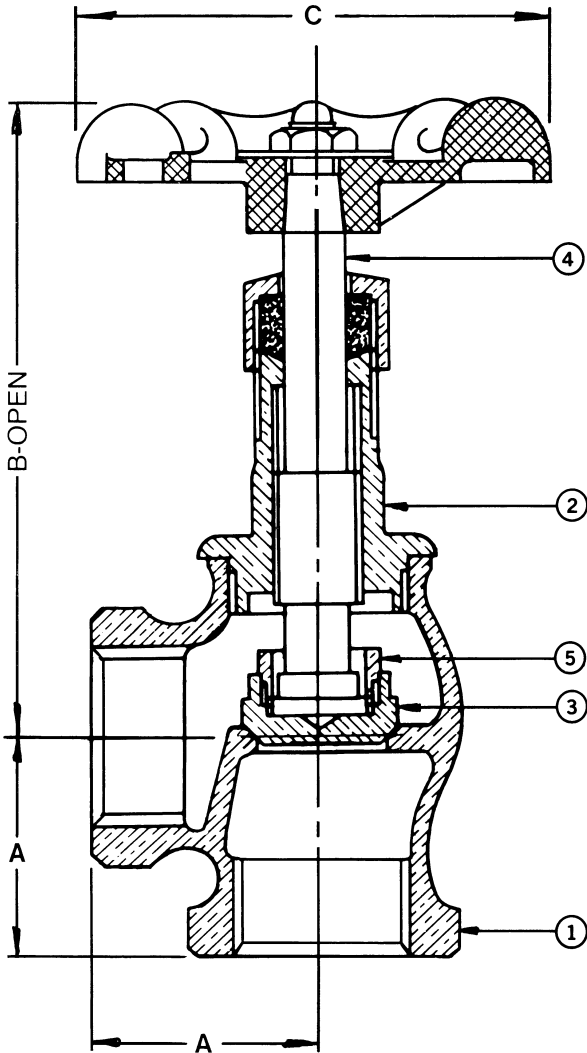

DIMENSIONS - INCHES / MILLIMETERS

Units	Size	A	B	C
Inches	1/4	3/4	3 1/16	2
MM	6.35	19.05	77.80	50.80
Inches	3/8	29/32	3 3/16	2
MM	9.53	23.01	80.98	50.80
Inches	1/2	1	3 5/8	2 1/4
MM	12.70	25.40	92.08	57.15
Inches	3/4	1 1/4	3 15/16	2 1/2
MM	19.05	31.75	100.03	63.50
Inches	1	1 7/16	4 3/8	2 3/4
MM	25.40	36.53	111.13	69.85
Inches	1 1/4	1 11/16	5 3/16	3 1/8
MM	31.75	42.88	131.78	79.38
Inches	1 1/2	1 13/16	5 3/4	3 1/2
MM	38.10	46.05	146.05	88.90
Inches	2	2 3/16	6 3/4	4
MM	50.80	55.58	171.45	101.60
Inches	2 1/2	3	8 5/8	4 3/4
MM	63.50	76.20	219.08	120.65

† Non-Shock

INNOVATION IN EVERY VALVE



MILWAUKEE VALVE