

GATE 1184

BRONZE

300 lb. SWP-1000 lb. WOG† • Heavy Duty Service
 Solid Wedge Disc • Rising Stem • Stainless Seat • Gland Packed
 Union Bonnet • Threaded Ends

PATENTED

Wear-resistant stainless seat rings are securely expanded into the body to assure trouble-free service. Normal seating wear is restricted to the bronze wedge and can be easily replaced.

SPECIFICATIONS

1184	Conforms to: MSS SP-80, Type 2, Class 300, Threaded Ends.
------	---

MATERIAL LIST

NO.	PART	MATERIAL	SPECIFICATION
1	Body	Bronze	ASTM B 61
2	Bonnet	Bronze	ASTM B 61
3	Wedge Disc	Bronze	ASTM B 61
4	Stem	Bronze	ASTM B 61
5	Union Bonnet Nut	Bronze	ASTM B 61
6	Seat Ring	St. Steel	ASTM A 167
7	Gland	Bronze	ASTM B 16
8	Packing Nut	Bronze	Commercial
9	Handwheel	Mall. Iron	Commercial
10	Identification Plate	Aluminum	Commercial
11	Handwheel Nut	Bronze	Commercial
12	Packing	Non-Asbestos	Commercial

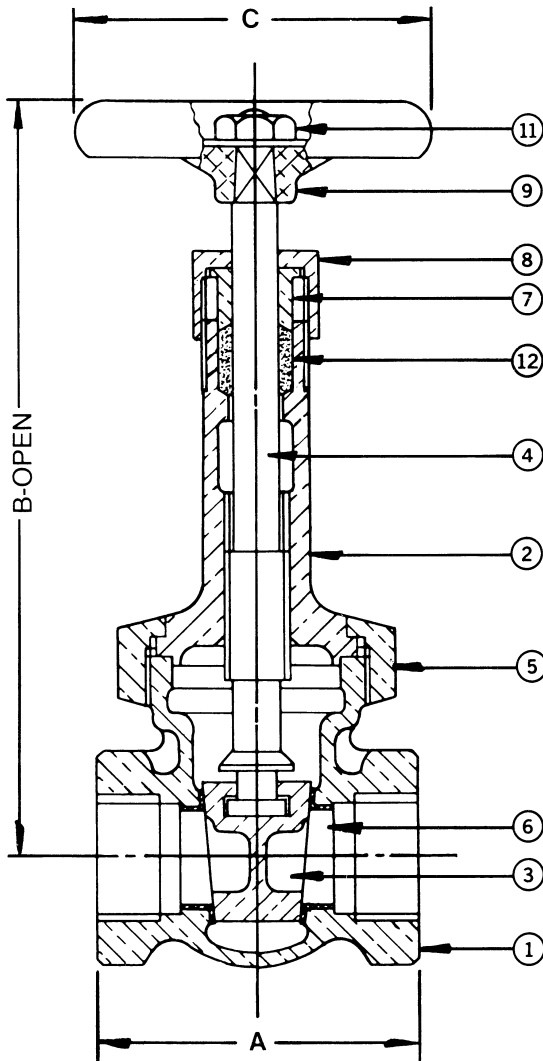

DIMENSIONS - INCHES / MILLIMETERS

Units	Size	A	B	C
Inches	1/4	1 13/16	5 1/8	2 1/4
MM	6.35	46.05	130.18	57.15
Inches	3/8	1 7/8	5 1/8	2 1/4
MM	9.53	47.63	130.18	57.15
Inches	1/2	2 1/4	5 1/2	2 1/2
MM	12.70	57.15	139.70	63.50
Inches	3/4	2 1/2	6 1/4	2 3/4
MM	19.05	63.50	158.75	69.85
Inches	1	3	7 3/16	2 3/4
MM	25.40	76.20	182.58	69.85
Inches	1 1/4	3 3/8	8 9/16	3 1/4
MM	31.75	85.73	217.50	82.55
Inches	1 1/2	3 1/2	9 5/8	3 3/4
MM	38.10	88.90	244.48	95.25
Inches	2	3 3/4	11 3/4	4 1/4
MM	50.80	95.25	298.45	107.95
Inches	2 1/2	4 5/8	14 1/2	4 3/4
MM	63.50	117.48	368.30	120.65
Inches	3	5	16 3/4	5 1/2
MM	76.20	127.00	425.45	139.70

† Non-Shock

INNOVATION IN EVERY VALVE



MILWAUKEE VALVE