

GATE 1156

BRONZE

200 lb. SWP-400 lb. WOG† • Industrial Service
 Solid Wedge Disc • Rising Stem • Cu-Ni Seat
 Union Bonnet • Gland Packed • Threaded Ends

SPECIFICATIONS

1156	Conforms to: MSS SP-80, Type 2, Class 200, Threaded Ends.
------	--

MATERIAL LIST

NO.	PART	MATERIAL	SPECIFICATION
1	Body	Bronze	ASTM B 61
2	Bonnet	Bronze	ASTM B 61
3	Wedge Disc	Bronze	ASTM B 61
4	Stem	Bronze	ASTM B 61
5	Union Bonnet Nut	Bronze	ASTM B 61
6	Seat Ring	Cu-Ni	90-10
7	Packing	Non-Asbestos	Commercial
8	Gland	Bronze	ASTM B 16
9	Packing Nut	Bronze	Commercial
10	Handwheel	Mall. Iron	Commercial
11	Identification Plate	Aluminum	Commercial
12	Handwheel Nut	Bronze	Commercial

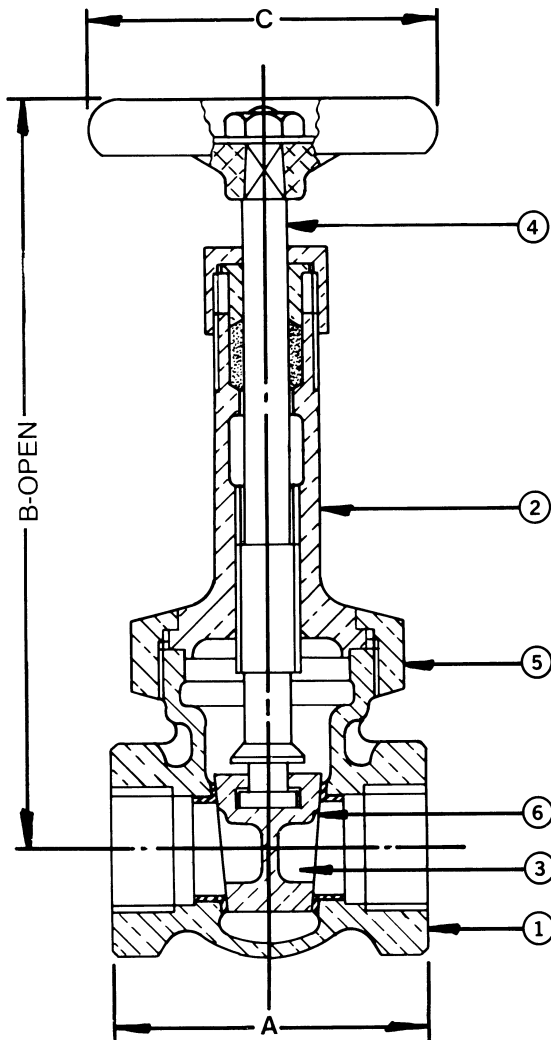

DIMENSIONS - INCHES / MILLIMETERS

Units	Size	A	B	C
Inches	1/4	1 13/16	5 1/8	2 1/4
MM	6.35	46.05	130.18	57.15
Inches	3/8	1 7/8	5 1/8	2 1/4
MM	9.53	47.63	130.18	57.15
Inches	1/2	2 1/4	5 1/2	2 1/2
MM	12.70	57.15	139.70	63.50
Inches	3/4	2 1/2	6 1/4	2 3/4
MM	19.05	63.50	158.75	69.85
Inches	1	2 7/8	7 3/16	2 3/4
MM	25.40	73.03	182.58	69.85
Inches	1 1/4	3 1/4	8 9/16	3 1/4
MM	31.75	82.55	217.50	82.55
Inches	1 1/2	3 1/2	9 9/16	3 3/4
MM	38.10	88.90	242.90	95.25
Inches	2	3 3/4	11 3/4	4 1/4
MM	50.80	95.25	298.45	107.95

† Non-Shock

INNOVATION IN EVERY VALVE



MILWAUKEE VALVE