

GATE 1152

BRONZE

125 lb. SWP-200 lb. WOG† • Industrial Service
 Solid Wedge Disc • Rising Stem
 Union Bonnet • Gland Packed • Threaded Ends

SPECIFICATIONS

1152	Conforms to: MSS SP-80. Type 2, Class 125, Threaded Ends.
------	--

MATERIAL LIST

NO.	PART	MATERIAL	SPECIFICATION
1	Body	Bronze	ASTM B 62
2	Bonnet	Bronze	ASTM B 62
3	Wedge Disc	Bronze	ASTM B 62
4	Stem	Bronze	ASTM B 62
5	Union Bonnet Nut	Bronze	ASTM B 62
6	Packing	Non-Asbestos	Commercial
7	Gland	Bronze	ASTM B 16
8	Packing Nut	Bronze	Commercial
9	Handwheel	Mall. Iron	Commercial
10	Identification Plate	Aluminum	Commercial
11	Handwheel Nut	Bronze	Commercial

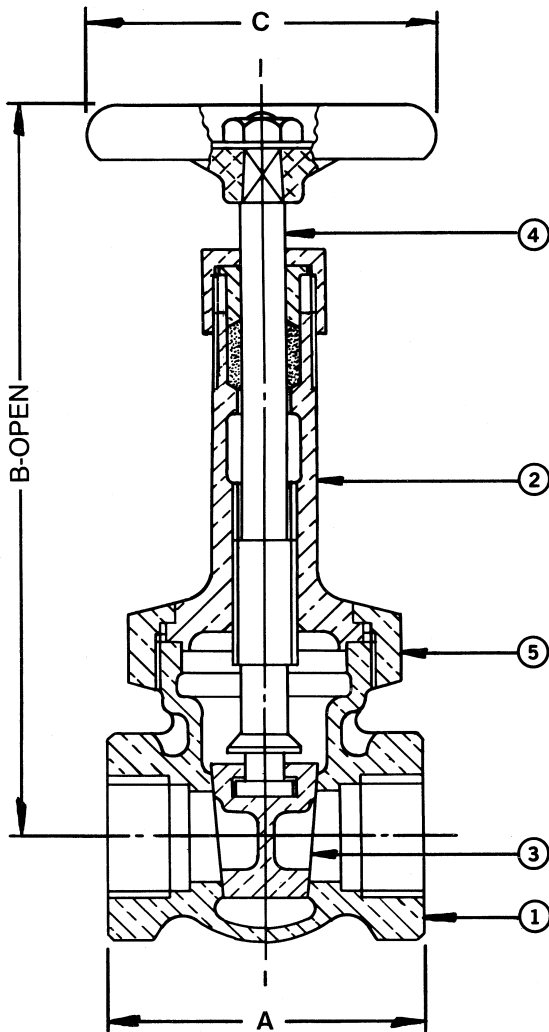

DIMENSIONS - INCHES / MILLIMETERS

Units	Size	A	B	C
Inches	1/4	1 3/4	5 1/8	2
MM	6.35	44.45	130.18	50.80
Inches	3/8	1 7/8	5 1/8	2
MM	9.53	47.63	130.18	50.80
Inches	1/2	2 1/8	5 1/2	2 1/2
MM	12.70	53.98	139.70	63.50
Inches	3/4	2 1/4	6 1/4	2 3/4
MM	19.05	57.15	158.75	69.85
Inches	1	2 9/16	7 3/16	2 3/4
MM	25.40	65.10	182.58	69.85
Inches	1 1/4	2 3/4	8 9/16	3 1/8
MM	31.75	69.85	217.50	79.38
Inches	1 1/2	3 1/4	9 5/8	3 1/2
MM	38.10	82.55	244.48	88.90
Inches	2	3 5/8	11 3/4	4
MM	50.80	92.08	298.45	101.60
Inches	2 1/2	4 1/2	14 1/2	4 3/4
MM	63.50	114.30	368.30	120.65
Inches	3	4 7/8	16 3/4	5 1/4
MM	76.20	123.83	425.45	133.35

† Non-Shock

INNOVATION IN EVERY VALVE



MILWAUKEE VALVE

The information presented on this sheet is correct at the time of publication. Milwaukee Valve reserves the right to change design, and/or material specifications without notice. For the most current information access www.milwaukeevalve.com

www.milwaukeevalve.com