





# **METAL\*AIRE®**

## ***CEILING DIFFUSERS***

### **PRODUCT CATALOG**

The METAL\*AIRE Ceiling Diffuser Catalog is designed to save you time selecting air distribution equipment. The Ceiling Diffuser Catalog is divided into productlines. Each section begins with a summary that includes all our available models along with features and benefits of our products.

To obtain product information not included in this catalog, simply go to our web site at [www.metalaire.com](http://www.metalaire.com), or refer to our InfoSource catalogs.

**Revised: August 17, 2006**



At METAL\*AIRE®, we continually work to improve our products. Product descriptions, dimensions, and performance are subject to change without notice. For the most current available literature visit our web page at [www.metalaire.com](http://www.metalaire.com). Contact your local METAL\*AIRE® representative to verify product or performance details.

# TABLE OF CONTENTS

## RCD • ROUND CEILING DIFFUSERS

RCD

Fixed Round Diffusers • Multi-Cone	
✦ Model 900 .....	10
Adjustable Round Diffusers • 3 Cone	
✦ Series 3000 .....	14
Fixed/Adjustable Round Diffusers • 2 Cone	
✦ Series 3100 .....	18
Adjustable Round Diffusers	
✦ Model 3200 .....	22
Round Architectural Ceiling Diffuser	
✦ Model R5750 .....	26

## DCD • DIRECTIONAL CEILING DIFFUSERS

DCD

Square/Rectangular Louver Face Ceiling Diffusers	
✦ Series 5000 .....	34
✦ Series 5500 .....	46
✦ Series 5500S .....	48
Square/Rectangular Diffusers • Economical	
✦ Series 5200 .....	58
Square Face Diffusers • Round Neck • 2-Cone	
✦ Series 5700 .....	62
Square Panel Diffusers • Round Neck • Uni-Flow Panel Face	
✦ Series 5750 .....	68
Square Face Diffusers • Round Neck • 3-Cone	
✦ Series 5800 .....	74
Square Panel Face Diffusers • Round Neck • Ultra High-Performance	
✦ Series Phenomenator® .....	80
Concentric Supply/Return Ceiling Diffusers • Louvered Face • Cube Core	
✦ Series 5500 DAF-CC5 .....	84
Square/Rectangular Diffusers • Modular Core • Supply • Mod-Flo	
✦ Series 9000 .....	94

## PCD • PERFORATED CEILING DIFFUSERS

PCD

Perforated Supply Diffuser • Curved Blade Pattern Controller	
✦ Series 7000 .....	104
Perforated Screen • Non Ducted • Return	
✦ Series PRTB .....	112
Perforated Supply/Return Diffuser • Fiberglass Backpan	
✦ Series 7300 .....	114
Perforated Supply/Return Diffuser • Fiberglass Backpan	
✦ Series 7350 .....	116
Perforated Ceiling Diffuser • Face Mounted Adjustable Pattern Controller	
✦ Series 7500 .....	118



# TABLE OF CONTENTS

## **PCD • PERFORATED CEILING DIFFUSERS** (CONT'D)

**PCD** –

Perforated Ceiling Diffuser • Curved Blade • Neck Mounted Pattern Controller	
✦ Series 7600 .....	134
Perforated Modular Core Diffuser • Aluminum	
✦ Series 7900 .....	150
Perforated Modular Core Diffuser • Steel Backpan • Square Neck • Mod-Flo	
✦ Series 7950 .....	156
Perforated Filter Return Diffuser • Square Neck	
✦ Series 7550R-F/7650R-F .....	160

## **LSD • LINEAR SLOT DIFFUSERS**

**LSD** –

Supply/Return Linear Slot Diffusers w/ Integral Volume/Directional Pattern Controllers	
✦ Series 6600/6600R .....	166
Supply/Return Linear Slot Diffuser for Spiral Pipe	
✦ Series 6600SP/6600SPR .....	184
Boot Plenums • Insulated/Non Insulated for 6600	
✦ Series BP .....	190
Linear Louver Diffusers	
✦ Series L-5000 .....	200

## **PSD • PLENUM SLOT DIFFUSERS**

**PSD** –

Plenum Slot Diffusers • Adjustable Pattern Controller	
✦ Series PHP .....	206
High Capacity Plenum Slot Diffuser • Fixed Pattern Controller	
✦ Series PHC .....	224
Light Troffer Diffuser • Fixed Pattern Controller	
✦ Series LT .....	230

## **ARP • ARCHITECTURAL DIFFUSERS**

**ARP** –

Louvered Face • Fixed Deflection	
✦ Series 5500DD .....	242
Modular Slot	
✦ Series 6600SQ .....	248

# TABLE OF CONTENTS

## **EHD • ENVIRONMENTAL/HOSPITAL DIFFUSERS**

**EHD**

Environmental/Hospital Diffusers • Laminar Flow	
✦ Series HPL-CL .....	260
Environmental/Hospital Diffusers • Laminar Flow • w/HEPA Filter Cell	
✦ Series HPL-HA .....	266
Environmental/Hospital Diffusers • Laminar Flow • For Patient Isolation Applications	
✦ Series HPL-PR .....	272
Environmental/Hospital Diffusers • Radial Discharge Pattern • Removable Face	
✦ Series HRD-CL .....	278
Environmental/Hospital Diffusers • Radial Discharge Pattern • Removable Face • w/HEPA Filter Cell	
✦ Series HRD-HA .....	284
Environmental/Hospital Diffusers • Laminar Flow • Operating Room Systems	
✦ Series Periflow .....	290

## **EPP • ENGINEERED POLYMER PRODUCTS**

**EPP**

Engineered Polymer Ceiling Diffusers • Louver Face	
✦ Series EP5000 .....	300
Engineered Polymer Cube Core • Eggcrate Return/Exhaust	
✦ Series EPCC5 .....	304
Engineered Polymer Grilles & Registers • Louver Face Return/Exhaust	
✦ Series EPRH .....	308

## **MDC® • METALAIRE DIGITAL CONTROL DIFFUSER**

**MDC**

METALAIRE Digital Control Diffuser	
✦ Series MDC® .....	316

## **UFD • UNDERFLOOR DIFFUSER**

**UFD**

Aircell Polymer Floor Diffuser	
✦ Series WFO .....	332



***ROUND CEILING DIFFUSERS***



**Model 900**  
Pg. 10

## Fixed Round Diffusers - Aluminum - Multi-Cone - Model 900

- ✦ Economical high performance diffuser
- ✦ Damper available (900D)



**Model 3000**  
(Flush Face Shown)  
Pg. 14

## Adjustable Round Diffusers - Aluminum - 3-Cone - Series 3000

- ✦ High induction/capacity 3 cone adjustable diffuser
- ✦ Fully adjustable from horizontal to vertical discharge
- ✦ Low profile flush face or dropped face designs are available

Adjustable	
3000-1	Flush
3000-2	Dropped



**Model 3100**  
(Flush Face Shown)  
Pg. 18

Series 3100 - Aluminum  
Series 3100S - Steel

## Fixed/Adjustable Round Diffusers - Aluminum/Steel - Multi-Cone - Series 3100

- ✦ High induction/capacity 2 cone diffuser
- ✦ Can be adjusted for vertical or horizontal discharge
- ✦ Low profile flush face or dropped face designs are available

	Aluminum		Steel	
Adjustable	3100A-1 Flush	3100A-2 Dropped	3100S-A-1 Flush	3100S-A-2 Dropped
Fixed	3100-1 Flush	3100-2 Dropped	3100S-1 Flush	3100S-2 Dropped



**Model 3200**  
Pg. 22

## Adjustable Round Diffusers - Steel - Model 3200

- ✦ Excellent choice for high capacity applications such as factories, gymnasiums, theaters, and convention halls
- ✦ Discharge pattern is easily adjusted from vertical to horizontal with adjustment ring
- ✦ Diffuser can effectively be applied for either spot heating or cooling
- ✦ In the horizontal setting the unit provides tight ceiling patterns excellent for VAV applications
- ✦ Outer cone design guards against ceiling smudging in horizontal position



**Model R5750**  
Pg. 26

## Round Architectural Ceiling Diffuser - Steel - Model R5750

- ✦ Architectural pleasing round diffuser blends well into the ceiling surface
- ✦ Fixed horizontal throw pattern
- ✦ Designed for surface mounting applications
- ✦ Excellent in both heating and cooling applications
- ✦ The R5750 is an excellent choice for VAV applications

# LEADING THE INDUSTRY IN PRODUCT LITERATURE

With the choice of our Pre-Flite Catalog, Quick Select Catalog, InfoSource Catalog, InfoSource CD and our web site, [www.metalaire.com](http://www.metalaire.com), you pick the format for product information that best suits your air distribution design needs.

## Pre-Flite - Product Overview Catalog

The METALAIRES Pre-Flite catalog is a condensed reference guide containing concise listings of our entire product line including grilles, registers, diffusers, and air terminal units. This catalog can be used to help select the type of device, along with available border styles. The catalog includes photos of each model along with the features and model guide, a great tool when you are trying to select a device for your project.



## Quick Select Catalog - Air Distribution Selection Made Easy

The METALAIRES Quick Select Catalog is designed to save you time selecting air distribution equipment. This catalog is a compact version of our InfoSource Catalogs and includes drawings and performance for our most popular products. The Quick Select Catalog is broken into product types with each section beginning with a model summary that includes features and benefits of our products. To obtain product information not included in the Quick Select Catalog, simply go to our web site at [www.metalaire.com](http://www.metalaire.com).



## InfoSource Catalog Suite - Complete guide to Air Distribution Selection

The METALAIRES InfoSource Catalog suite is the leading product catalog in the industry. Included in these catalogs are the complete product listings, drawings, product features and benefits, product performance data, specifications, and model specifications. These catalogs are organized to make it quick and easy to find the information you are looking for.

### InfoSource Catalog Suite

- Ceiling Diffusers Catalog
- Grilles & Registers Catalog
- Air Terminal Unit Catalog
- Formations Catalog



## InfoSource CD

Our InfoSource CD has set the standard in the industry for air distribution product selection. This CD contains a complete library of all our catalogs and submittals along with our air terminal unit selection program.



## Web Site: [www.metalaire.com](http://www.metalaire.com)

METALAIRES leads the industry with a web site that contains all the product literature and performance data needed to design your air distribution system. Our web site includes all our submittals, catalogs, installation manuals, as well as other valuable information to aid you in air distribution design.



# RCD - Round Ceiling Diffusers

8/2006

## ➔ Fixed Round Diffusers ➔ Model 900 ➔ Aluminum

### Product Details

- ★ Economical high performance diffuser
- ★ Damper available (900D)



**Model 900-1 Shown**

Standard Finish: 01 White

Dimensions are in inches

Fixed Round Diffuser - Multi Cone  
Surface Mount  
Model 900-1

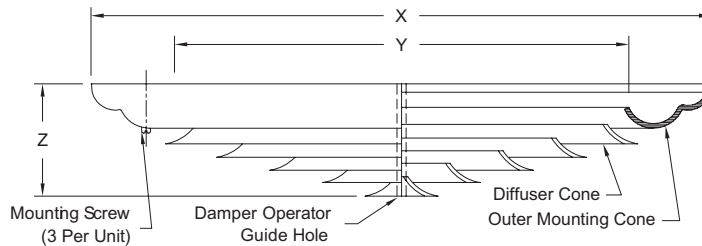

Fixed Round Diffuser - Multi Cone - With Damper  
Surface Mount  
Model 900D-1

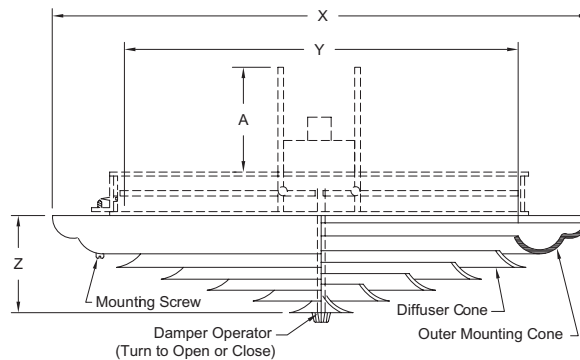

Diffuser Size	X	Y	Z	Number of Cones
6	10 1/8	5 7/8	1 7/8	4
8	12 1/8	7 7/8	2 3/16	5
10	14 1/8	9 7/8	2 1/2	6
12	16 1/8	11 7/8	2 13/16	7
14	18 1/8	13 7/8	3 1/8	8

Damper Size	A
6	3
8	4
10	5
12	6
14	6 1/4

1. Available Finishes	2. Available Accessories	3. Construction Details
<b>Standard Finish:</b> 01 White  <b>Optional Finish</b> 02 Aluminum 28 Custom Color	<b>900D - Round Damper</b> .....335 Replacement Knobs	• Sizes only as listed

Round Ceiling Diffusers



RCD



## Model 900 - Performance

Neck Size	fpm	200	300	400	500	600	700	800	900	1000
		Pt	.005	.010	.015	.025	.035	.050	.065	.080
6"	CFM	37	55	75	90	110	130	145	165	185
	Throw NC	3-5 <	3-5 <	3-6 <	3-6 <	4-6 20	4-6 23	4-6 25	5-7 25	5-7 30
8"	CFM	65	100	135	165	200	230	265	300	330
	Throw NC	4-6 <	4-6 <	4-6 <	5-7 20	5-8 25	5-8 25	5-8 28	5-9 30	6-10 35
10"	CFM	105	160	210	265	315	370	420	475	525
	Throw NC	4-7 <	5-8 <	5-9 <	5-10 20	6-11 25	6-12 30	7-13 30	7-14 35	7-14 35
12"	CFM	150	230	305	380	455	535	610	685	760
	Throw NC	5-8 <	5-9 <	6-10 20	6-11 25	6-12 25	7-13 30	7-14 30	6-16 35	10-18 35
14"	CFM	200	310	415	520	625	730	830	935	1040
	Throw NC	6-9 <	7-11 <	8-13 20	9-14 25	11-15 30	12-17 30	13-19 35	15-21 35	18-23 40

**Performance Notes for Series 900:**

All data are tested in accordance with ANSI/ASHRAE 70-1991

**Definition of Units:**

- CFM - Cubic feet per minute (air)
- fpm - Velocity of air stream in feet per minute
- Pt - Total pressure (inches of water column)
- Throw - Throw distance in feet at terminal velocities of 150 - 100 fpm with a supply air temperature 20°F cooler than room temperature
- NC - Noise criterion, sound pressure level. NC ratings are based on sound power level (Lw) RE:10E-12 watts minus a 10 dB room attenuation in all octave bands

### Round Damper for Series 900 ➔ Aluminum ➔ Model 900D

- ✦ For attachment to Model 900
- ✦ 2 butterfly style blades for 6" - 12" sizes
- ✦ 8 blade radial style for 14" size
- ✦ Blades adjusted through diffuser face
- ✦ Damper supplied with mounting hardware



Dimensions are in inches

#### Butterfly Damper - Size 12 and Under - Aluminum

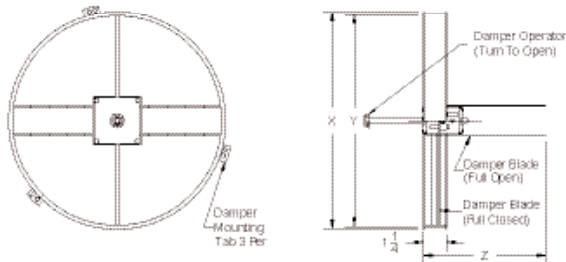

#### Opposed Blade Damper - Size 14 for Series 900 - Aluminum

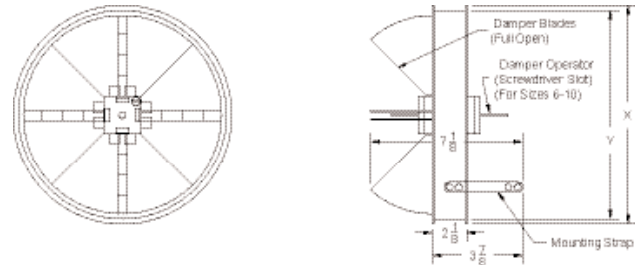

900D Models			
Diffuser Sizes	X	Y	Z
6	5 15/16	5 5/8	3
8	7 15/16	7 5/8	4
10	9 15/16	9 5/8	5
12	11 15/16	11 5/8	6
14	13 15/16	13 5/8	7



## Model 900 - Specifications

Air Outlets shall be model 900 manufactured by METALAIR®. Diffuser shall have a series of uniformly spaced concentric round cones. Units shall be aluminum construction. The units shall be the size and quantity as outline in the plans and specifications.

Unit's cones shall be drop down and provide an efficient horizontal radial discharge pattern. Diffuser shall include countersunk screw holes for installation into the ceiling system. Center cone of diffuser shall include an access hole to allow face adjustment of an optional damper operator.

### Optional Accessories

#### 900 Series Damper

Outlets shall be installed with a neck-mounted damper, model 900D, manufactured by METALAIR®. Damper shall be of aluminum construction and designed to give jam-free operation. Sizes 6" – 12" round dampers shall be 2 blade, butterfly type. Size 14" damper shall be an 8 blade opposed blade damper. Units shall include a damper operator knob constructed of high impact nylon. Damper knob shall be removable to prevent tampering after the outlet is balanced.

### Performance Specification

The manufacturer shall provide published performance data. Data shall be tested in accordance to ANSI/ASHRAE Standard 70-1991.

### Paint Specification

Process shall be anodic electrodeposition using an anodic acrylic paint. Units shall undergo pre-treatment including a pressurized spray stage using an alkaine cleaner and a de-ionized water rinse.

Film Properties shall meet or exceed the following standards:

Property	Test Method	Performance
Film thickness		.8-1.0 mils
Film Cure		320 F @ 20 min
Gloss – 60 deg.	ASTM D523-89	70-80%
Pencil Hardness	ASTM D3363-92A	HB-H
Crosshatch Adhesion	ASTM D3359-95	4B-5B
Direct Impact	ASTM D2794-93	100 in.lbs. Min
Reverse Impact	ASTM D2794-93	60 in.lbs. Min.
Salt Spray	ASTM B117-95	48-96 Hours
Humidity	ASTM D1735-92	500 Hours
Water Soak	ASTM D870-92	250 Hours



## Model 900 - Model Specification Guide

Fixed Round Diffusers - Multi Cone  
Model 900 - Aluminum

Model	Available Neck		Available Finishes	Available Options	
900-1 - Surface Mount	6	6" round	Standard	900D	Aluminum Damper
	8	8" round	01 - White	EK	Extra Knots
	10	10" round	Optional		
	12	12" round	02 - Aluminum		
	14	14" round			

# RCD - Round Ceiling Diffusers

8/2006

## Adjustable Round Diffusers Series 3000 Aluminum

### Product Details

- High induction/capacity 3 cone adjustable diffuser
- Fully adjustable from horizontal to vertical discharge
- Low profile flush face, or dropped face designs are available



**Model 3000-1 Shown**

Standard Finish: 01 White

Dimensions are in inches

### Adjustable Round Diffuser - 3 Cone Flush Cone Model 3000-1

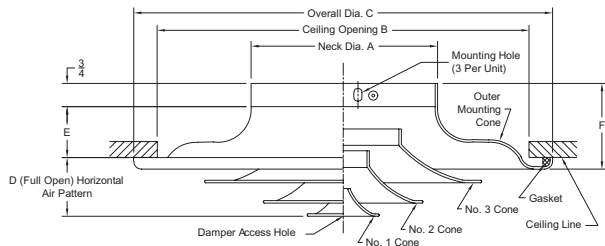

### Adjustable Round Diffuser - 3 Cone Flush Cone - With D3 Damper Model 3000-1D

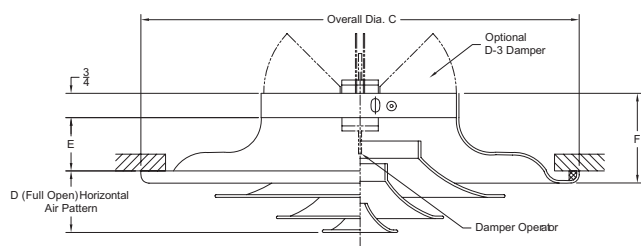

### Adjustable Round Diffuser - 3 Cone Drop Cone Model 3000-2

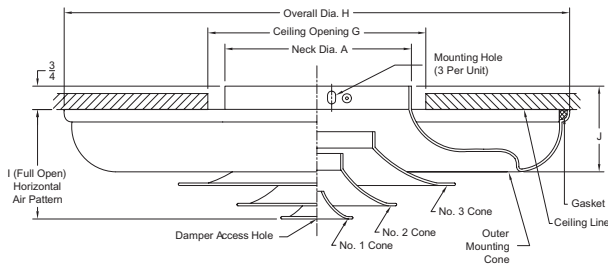

### Adjustable Round Diffuser - 3 Cone Drop Cone - With D3 Damper Model 3000-2D

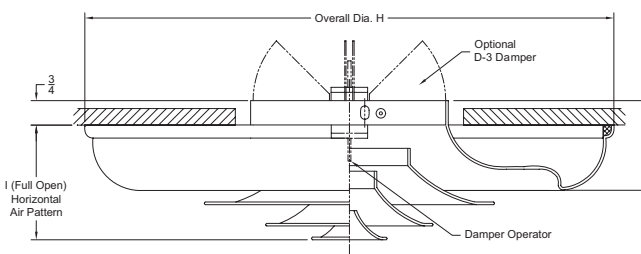

Neck Size	A	B	C	D	E	F	G	H	I	J
6	5 7/8	12	13 1/2	2 1/4	1 5/8	2 3/4	7	16 5/16	3 7/8	2 3/4
8	7 7/8	16	18	2 5/8	2 1/8	3 3/8	9	23 3/16	4 3/4	3 3/8
10	9 7/8	20	22 1/2	2 15/16	2 5/8	4	11	27 3/16	5 9/16	4
12	11 7/8	24	27	3 1/2	3 1/4	4 5/8	13	31 13/16	6 3/4	4 5/8
14	13 7/8	28	31 1/2	4 1/4	3 3/4	5 1/4	15	36 7/8	8	5 1/4
16	15 7/8	32	36	4 5/8	4 1/4	6	17	42 1/4	8 7/8	6
18	17 7/8	36	40 1/2	5	4 7/8	6 5/8	19	47 9/16	9 7/8	6 5/8
20	19 7/8	40	45	5 3/8	5 3/8	7 1/4	21	52 3/8	10 3/4	7 1/4
24	23 7/8	40	45	5 3/8	5 3/8	7 1/4	25	52 3/8	10 3/4	7 1/4



# RCD - Round Ceiling Diffusers

Round Ceiling Diffusers



RCD

1. Available Finishes	2. Available Accessories	3. Available Options	4. Construction Details
<b>Standard Finish:</b> 01 White <b>Optional Finish</b> 02 Aluminum paint 03 Black 24 Mill finish 28 Custom color	<b>Shipped Unattached</b> D3 - Aluminum Radial Opposed Blade Damper . . .336 SD3 - Steel Radial Opposed Blade Damper . . . .336 G3 - Equalizing Grid . . . . .337 GD3 - Combination Grid/Damper . . . . .337 BDS - Butterfly Damper . . . . .335 RSD - Radial Shutter Damper . . . . .336	Safety Chain	• Sizes only as listed

## Series 3000 - Performance

### Models 3000 (-1, -2)

Neck Size	Neck Area in Sq. Ft.	fpm Neck Vel.										
		Pv	400	500	600	700	800	900	1000	1200	1400	1600
		Ps Horiz. Ps Vert.	0.011 0.019	0.018 0.03	0.026 0.043	0.035 0.058	0.046 0.075	0.059 0.096	0.072 0.115	0.105 0.17	0.145 0.225	0.190 0.3
6"	0.2	CFM Throw NC	80 1-3 <	100 2-4 <	110 2-5 <	140 3-6 20	160 3-7 24	180 3-8 27	200 4-8 36	240 4-9 36	280 5-10 39	320 6-12 44
8"	0.35	CFM Throw NC	140 2-4 <	175 2-5 <	210 3-6 <	245 3-7 20	280 4-8 24	315 4-10 27	350 5-11 31	420 5-13 36	490 6-14 39	560 7-16 44
10"	0.55	CFM Throw NC	220 2-5 <	270 3-6 <	330 3-7 <	380 4-8 21	435 5-10 25	490 6-11 28	545 6-12 32	655 7-14 37	765 8-18 40	870 9-21 45
12"	0.79	CFM Throw NC	315 3-7 <	390 3-8 <	470 4-10 20	550 5-11 22	630 6-13 26	710 7-15 29	785 8-17 33	940 9-19 38	1100 10-21 41	1260 12-25 46
14"	1.07	CFM Throw NC	425 3-8 <	535 4-9 <	640 5-11 20	750 6-13 23	855 7-16 27	965 8-18 31	1070 9-20 34	1285 11-13 40	1500 13-26 43	1710 15-30 48
16"	1.4	CFM Throw NC	560 4-9 <	700 5-10 <	840 5-13 21	980 6-15 24	1120 7-17 28	1260 9-21 33	1400 10-23 36	1680 12-27 41	1960 14-30 44	2240 16-35 49
18"	1.77	CFM Throw NC	710 4-10 <	885 5-12 <	1060 6-15 21	1240 7-17 25	1420 9-21 29	1595 11-23 34	1770 13-26 37	2120 15-31 42	2480 16-34 45	2830 18-38 51
20"	2.18	CFM Throw NC	875 4-11 <	1090 6-14 20	1310 7-16 22	1525 8-19 26	1745 9-23 30	1965 11-23 36	2180 13-28 39	2620 15-33 44	3060 18-38 47	3490 20-42 53
24"	3.14	CFM Throw NC	1255 12-24 22	1570 13-26 26	1885 14-28 28	2200 15-30 31	2510 16-33 35	2825 17-35 38	3140 18-37 41	3770 20-40 47	4395 23-45 51	5025 25-50 55

### Performance Notes for Series 3000:

1. Tabulated radial throw in feet is based on a 9' ceiling height, ambient supply air, MAX Throw @ Vt = 75 fpm, MIN Throw @ Vt = 150 fpm, and the diffuser inner cones in down position for 360° horizontal air distribution pattern.
2. For vertical down protection air pattern with cooling supply air temperature 20° below room temperature and diffuser inner cones in up position: multiply the tabulated radial throw values by a factor of 0.80 to obtain vertical down projection distances at MIN and MAX (Vt) terminal velocities.
3. For vertical down projection air pattern with heating supply air temperatures 20° above room temperature and diffuser inner cones in up position; multiply the tabulated radial throw values by a factor of 0.60 to obtain vertical down projection distances at MIN and MAX (Vt) terminal velocities.
4. Velocity Pressure (Pv) and Static Pressure (Ps) are in inches of water.
5. Series 3000 Diffusers are tested in accordance with ASHRAE 70-1991. Sound data are calculated in accordance with International Standard ISO 3741 comparison method. The NC values are based on a room absorption of 10 dB for sound power level (Lw) RE: 10E-12 watts. < symbol indicated NC less than 20. The NC data are for single diffusers; for results of throttling a volume damper, see table below.
6. All data are applicable for exposed duct mounting or ceiling installation.

### Damper Throttling Correction Factors

% Register Damper Open	Add To Listed NC (1)*	Factor Times Listed Pt (2)*
100%	0 dB	1.0
82%	4 dB	1.5
70%	8 dB	2.0
50%	16 dB	4.0

(1) NC Addition to listed NC value.  
 (2) Pt Multiplier times listed Pt value.



## Series 3000 - Specifications

Air Outlets shall be model 3000 manufactured by METALAIR®. Diffuser shall be constructed of 3 round inner cones and a round outer cone. Outlet shall be adjustable to allow the discharge pattern to be set from full horizontal to vertical. Units shall be aluminum construction. The units shall be the size and quantity as outline in the plans and specifications.

Pattern adjustment shall be accomplished by rotating the innermost cone. The inner core assembly shall be removable for installation and for access into the ductwork. The center cone shall include an access hole to allow adjustment of an optional damper.

### **Model 3000-1 - Flush Cone**

Outlet shall have an outer cone that allows flush mounting to the ceiling opening.

### **Model 3000-2 - Drop Cone**

Outlet shall have a dropped outer cone to move the discharge jet away from the ceiling surface. Dropped cone shall minimize ceiling smudging.

## Performance Specification

The manufacturer shall provide published performance data. Data shall be tested in accordance to ANSI/ASHRAE Standard 70-1991.

## Paint Specification

Process shall be anodic electrodeposition using an anodic acrylic paint. Units shall undergo pre-treatment including a pressurized spray stage using an alkaine cleaner and a de-ionized water rinse.

Film Properties shall meet or exceed the following standards:

Property	Test Method	Performance
Film thickness		.8-1.0 mils
Film Cure		320 F @ 20 min
Gloss – 60 deg.	ASTM D523-89	70-80%
Pencil Hardness	ASTM D3363-92A	HB-H
Crosshatch Adhesion	ASTM D3359-95	4B-5B
Direct Impact	ASTM D2794-93	100 in.lbs. Min
Reverse Impact	ASTM D2794-93	60 in.lbs. Min.
Salt Spray	ASTM B117-95	48-96 Hours
Humidity	ASTM D1735-92	500 Hours
Water Soak	ASTM D870-92	250 Hours

# RCD - Round Ceiling Diffusers

## Series 3000 - Model Specification Guide

Adjustable Round Diffusers - 3 Cone  
Series 3000 - Aluminum

Model	Available Neck Sizes		Available Finishes	Available Options		Available Accessories	
3000-1 - Flush Mount 3000-2 - Drop Face	6	6" round	Standard	SC	Safety Chain	D3	Aluminum Radial Damper
	8	8" round	01 - White			SD3	Steel Radial Damper
	10	10" round	Optional			G3	Round Equalizing Grid
	12	12" round	02 - Aluminum			GD3	Combo Grid/Damper
	14	14" round	24 - Mill			BDS	Butterfly Damper
	16	16" round	03 - Black			RSD	Radial Shutter Damper
	18	18" round	28 - Custom Color				
	20	20" round					
	24	24" round					

# RCD - Round Ceiling Diffusers

8/2006

Round Ceiling Diffusers



RCD

➔ Fixed/Adjustable Round Diffusers ➔ Series 3100 ➔ Aluminum  
➔ Series 3100S ➔ Steel

## Product Details

- ★ High induction/capacity 2 cone diffuser
- ★ Can be adjusted for vertical or horizontal discharge
- ★ Available 3100 aluminum construction or 3100S steel construction
- ★ Low profile flush face or dropped face designs are available
- ★ 30" and 36" units are available in non-adjustable Aluminum models only



**Model 3100-1 Shown**

Standard Finish: 01 White

Dimensions are in inches

### Fixed Round Ceiling Diffuser - 2 Cone

#### Flush Cone

Model 3100-1 - Aluminum  
Model 3100S-1 - Steel

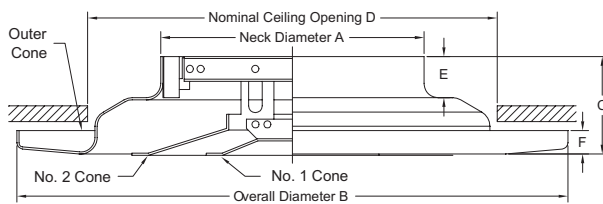

### Fixed Round Ceiling Diffuser - 2 Cone

#### Drop Cone

Model 3100-2 - Aluminum  
Model 3100S-2 - Steel

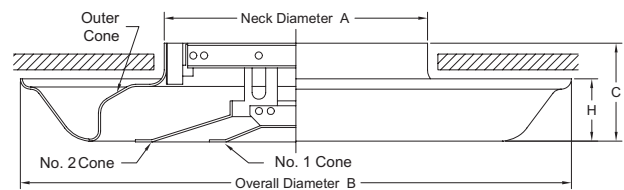

### Adjustable Round Ceiling Diffuser - 2 Cone

#### Flush Cone

Model 3100A-1 - Aluminum  
Model 3100AS-1 - Steel

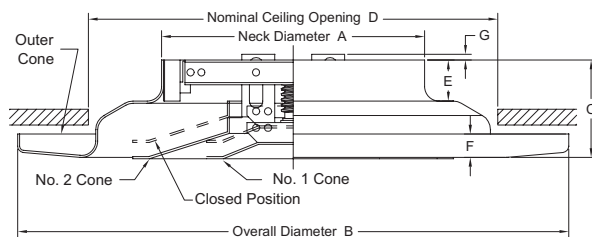

### Adjustable Round Ceiling Diffuser - 2 Cone

#### Drop Cone

Model 3100A-2 - Aluminum  
Model 3100SA-2 - Steel

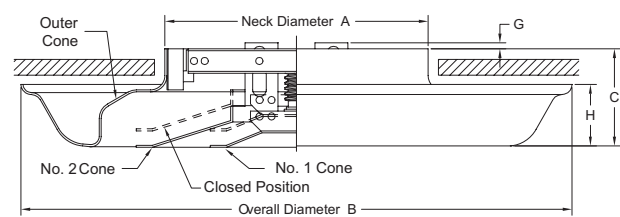

Dimensions								
Size	A	B	C	D	E	F	G	H
6	5 3/4	16 5/8	2 15/16	12	1 1/4	5/8	3/4	1 7/8
8	7 3/4	16 5/8	2 15/16	12	1 1/4	5/8	3/4	1 7/8
10	9 3/4	22 3/16	3 5/16	17	1 1/4	7/8	3/4	2 1/2
12	11 3/4	22 3/16	3 5/16	17	1 1/4	7/8	3/4	2 1/2
14	13 3/4	29 1/4	4 3/16	23	1 1/4	7/8	1 9/16	3 1/2
16	15 3/4	29 1/4	4 3/16	23	1 1/4	7/8	1 9/16	3 3/8
18	17 3/4	34 1/2	4 5/8	28	1 1/4	1	1 9/16	3 3/4
20	19 3/4	34 1/2	4 5/8	28	1 1/4	1	1 9/16	3 3/4
24	23 3/4	40 1/2	5 1/4	34	1 1/4	1	1 9/16	4 1/4
30	29 3/4	49 1/2	6 1/8	41	2 1/4	1 3/8	2 1/16	5 1/8
36	35 3/4	58 3/8	7 1/8	50	2 1/4	1 3/8	2 1/16	6 1/8

30" and 36" units are available in non-adjustable aluminum models only

# RCD - Round Ceiling Diffusers



**Fixed Round Ceiling Diffuser - 2 Cone**  
**Flush Cone - With Damper**  
 Model 3100-1D - Aluminum  
 Model 3100S-1D - Steel

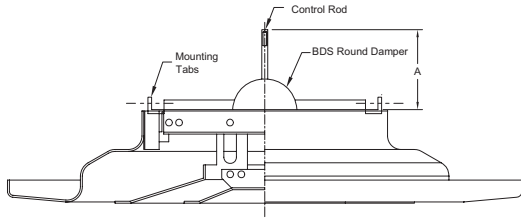

Dimensions	
Size	A
6	2 1/2
8	3 1/2
10	4 1/2
12	5 1/2
14	6 1/2
16	7 1/2

**Fixed Round Ceiling Diffuser - 2 Cone**  
**Drop Cone - With Damper**  
 Model 3100-2D - Aluminum  
 Model 3100S-2D - Steel

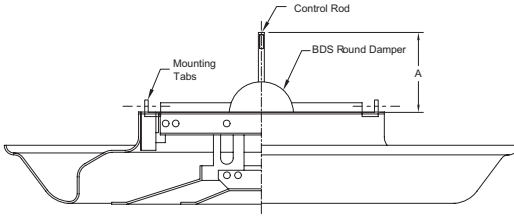

Dimensions	
Size	A
6	2 1/2
8	3 1/2
10	4 1/2
12	5 1/2
14	6 1/2
16	7 1/2

1. Available Finishes	2. Available Accessories	3. Available Options	4. Construction Details
<b>Standard Finish:</b> 01 White <b>Optional Finish</b> 02 Aluminum paint 03 Black 24 Mill finish 28 Custom color	<b>Shipped Unattached</b> D3 - Aluminum Radial Opposed Blade Damper . . .336 SD3 - Steel Radial Opposed Blade Damper . . . . .336 G3 - Equalizing Grid . . . . .337 GD3 - Combination Grid/Damper . . . . .337 BDS - Butterfly Damper . . . . .335 RSD - Radial Shutter Damper . . . . .336	Safety Chain	• Sizes only as listed

## Series 3100 - Performance

Models 3100 (-1, -2), 3100S (-1, -2)

Neck Size	Neck Area in Sq. Ft.	fpm Neck Vel.	400	500	600	700	800	900	1000	1200	1400	1600	
			Pv	0.01	0.016	0.023	0.031	0.04	0.051	0.063	0.09	0.122	0.16
			Ps Horiz. Ps Vert.	0.025 0.049	0.039 0.076	0.056 0.109	0.076 0.149	0.1 0.194	0.126 0.247	0.156 0.305	0.225 0.44	0.304 0.594	0.398 0.777
6"	0.188	CFM Throw NC	75 2-3-6 <18	94 3-4-8 <18	113 3-5-9 <18	132 4-5-11 18	151 4-6-12 19	169 5-7-14 23	188 5-8-16 26	226 6-9-19 32	264 7-11-22 36	301 9-13-26 40	
8"	0.338	CFM Throw NC	135 3-5-9 19	169 3-5-10 19	203 4-6-12 19	237 4-7-13 20	271 5-8-15 24	304 6-9-17 28	338 7-10-20 31	406 8-12-25 37	474 10-14-29 42	541 10-15-30 46	
10"	0.769	CFM Throw NC	213 4-16-12 20	266 4-7-13 20	319 5-7-15 23	372 5-8-17 26	425 6-9-18 29	479 7-10-20 31	532 7-11-23 34	638 9-14-27 40	745 11-16-32 45	851 12-18-36 49	
12"	1.05	CFM Throw NC	308 5-7-15 19	385 5-8-16 22	461 6-9-18 25	538 7-10-20 28	615 7-11-22 31	692 8-12-24 34	769 9-13-26 37	923 11-16-32 42	1077 12-19-37 47	1231 14-21-43 51	
14"	1.375	CFM Throw NC	420 6-9-18 22	525 6-10-19 25	630 7-11-21 28	735 8-12-23 31	840 8-13-25 34	945 9-14-28 37	1050 10-15-30 39	1260 12-18-36 44	1470 14-21-43 48	1680 17-25-57 52	
16"	1.743	CFM Throw NC	550 7-10-21 24	687 7-11-22 27	825 8-12-25 30	962 9-14-27 32	1100 10-15-30 35	1237 11-17-33 38	1375 12-18-37 40	1649 14-22-43 45	1924 17-25-50 50	2194 19-29-57 54	
18"	2.154	CFM Throw NC	697 8-12-24 25	871 9-13-27 28	1046 11-15-32 31	1220 11-16-32 33	1394 12-17-35 36	1568 13-19-38 39	1743 14-20-43 41	2091 16-24-48 46	2440 18-28-55 50	2788 21-32-64 54	
20"	3.109	CFM Throw NC	862 9-13-27 27	1077 10-15-30 30	1293 11-16-32 32	1508 12-18-36 35	1724 13-20-39 37	1939 14-22-43 39	2154 16-24-47 41	2585 19-28-56 45	3016 22-33-65 50	3447 24-36-72 54	
24"	3.109	CFM Throw NC	1224 12-18-36 28	1554 13-20-40 31	1885 15-22-45 33	2176 16-25-49 36	2487 18-27-54 38	2798 20-30-59 40	3109 21-32-64 42	3731 25-37-75 46	4353 28-42-84 50	4974 31-47-93 54	
30"	4.868	CFM Throw NC	1947 17-26-51 30	2434 19-29-54 32	2921 21-32-64 35	3408 24-35-71 37	3894 26-39-78 39	4381 28-42-85 41	4868 31-46-92 43	5842 35-53-105 47	6815 39-58-117 51	7789 42-63-127 54	
36"	7.02	CFM Throw NC	2808 24-36-72 31	3510 27-40-81 33	4212 30-45-90 36	4914 33-49-99 38	5616 36-54-108 40	6318 39-59-118 42	7020 42-63-127 44	8423 48-72-144 48	9827 53-79-158 57	11231 58-84-168 54	

30" and 36" units are available in non-adjustable aluminum models only

See Page RCD-20 for Performance Notes



**Performance Notes:**

1. Tabulated throw in feet is based on a 9' ceiling, with supply air temperature 20°F cooler than room temperature, MAX Throw @ Vt = 50 fpm, MIN Throw @ Vt = 150 fpm, and the diffuser/inner cones in down position for 360° horizontal air distribution pattern.

Example: 9-13-27

- .....Distance @ 50 fpm Term. Vel.
- .....Distance @ 100 fpm Term. Vel.
- .....Distance @ 150 fpm Term. Vel.

For vertical Ak values, multiply Ak by 0.76.

2. For vertical down projection air pattern with cooling supply air temperature 20° below room temperature, and diffuser inner cones in up position: multiply the tabulated radial throw values by a factor of 0.80 to obtain vertical down projection distances at MIN and MAX (Vt) terminal velocities.
3. For vertical down projection air pattern with heating supply air temperatures 20° above room temperature, and diffuser inner cones in up position: multiply the tabulated radial throw values by a factor of 0.60 to obtain vertical down projection distances at MIN and MAX (Vt) terminal velocities.
4. Velocity Pressure (Pv) and Static Pressure (Ps) are in inches of water.  $P_v + P_s = P_t$  (total pressure).
5. Series 3100 Round Adjustable Diffusers are tested in accordance with ASHRAE 70-1991. Sound data are calculated in accordance with International Standard ISO 3741 comparison method. The NC values are based on a room absorption of 10 dB for sound power level (Lw) RE: 10E-12 watts. < symbol indicates NC less than 20. The NC data is for a single diffusers; for results of throttling a volume damper, see table below.
6. All data is applicable for exposed duct mounting or ceiling installation.

**Damper Throttling Correction Factors**

% Register Damper Open	Add To Listed NC (1)*	Factor Times Listed Pt (2)*
100%	0 dB	1.0
82%	4 dB	1.5
70%	8 dB	2.0
50%	16 dB	4.0

*\*(1) NC Addition to listed NC value.  
\*(2) Pt Multiplier times listed Pt value.*

## Series 3100 - Specifications

### Fixed Round Diffuser - 2 Cone/Series 3100

Air outlets shall be model 3100 (aluminum) or 3100-S (steel) manufactured by METALAIRES®. Diffuser shall be constructed of 2 round inner cone assembly and a round outer cone. Outlet shall have a fixed horizontal pattern. Units shall be aluminum construction (model 3100) or steel construction (model 3100S). The units shall be the size and quantity as outline in the plans and specifications.

The inner core assembly shall be removable for installation and for access into the ductwork. The center cone shall include an access hole to allow adjustment of an optional damper.

**Flush Cone**

Model 3100-1 - Aluminum

Model 3100S-1 - Steel

Outlet shall have an outer cone that allows flush mounting to the ceiling opening.

**Drop Cone**

Model 3100-2 - Aluminum

Model 3100-S-2 - Steel

Outlet shall have a dropped outer cone to move the discharge jet away from the ceiling surface. Dropped cone shall minimize ceiling smudging.

### Adjustable Round Diffuser - 2 Cone/Series 3100A

Air outlets shall be model 3100A (aluminum) or 3100A-S (steel) manufactured by METALAIRES®. Diffuser shall be constructed of 2 round inner cone assembly and a round outer cone. Outlet shall be adjustable to allow the discharge pattern to be set from full horizontal to vertical. Units shall be aluminum construction (model 3100) or steel construction (model 3100S). The units shall be the size and quantity as outline in the plans and specifications.

Pattern adjustment shall be accomplished by rotating the innermost cone. The inner core assembly shall be removable for installation and for access into the ductwork. The center cone shall include an access hole to allow adjustment of an optional damper.

**Flush Cone**

Model 3100A-1 - Aluminum

Model 3100SA-1 - Steel

Outlet shall have an outer cone that allows flush mounting to the ceiling opening.

**Drop Cone**

Model 3100A-2 - Aluminum

Model 3100A-S-2 - Steel

Outlet shall have a dropped outer cone to move the discharge jet away from the ceiling surface. Dropped cone shall minimize ceiling smudging.

### Performance Specification

The manufacturer shall provide published performance data. Data shall be tested in accordance to ANSI/ASHRAE Standard 70-1991.



## Paint Specification

Process shall be anodic electrodeposition using an anodic acrylic paint. Units shall undergo pre-treatment including a pressurized spray stage using an alkaline cleaner and a de-ionized water rinse.

Film Properties shall meet or exceed the following standards:

Property	Test Method	Performance
Film thickness		.8-1.0 mils
Film Cure		320 F @ 20 min
Gloss – 60 deg.	ASTM D523-89	70-80%
Pencil Hardness	ASTM D3363-92A	HB-H
Crosshatch Adhesion	ASTM D3359-95	4B-5B
Direct Impact	ASTM D2794-93	100 in.lbs. Min
Reverse Impact	ASTM D2794-93	60 in.lbs. Min.
Salt Spray	ASTM B117-95	48-96 Hours
Humidity	ASTM D1735-92	500 Hours
Water Soak	ASTM D870-92	250 Hours

## Series 3100 - Model Specification Guide

### Fixed/Adjustable Round Diffuser - 2 Cone

#### Series 3100 - Aluminum

Model	Available Neck Sizes		Available Finishes	Available Options		Available Accessories	
3100-1 - Fixed	6	6" round	Standard	SC	Safety Chain	D3	Aluminum Radial Damper
3100A-1 - Adjustable	8	8" round	01 - White			SD3	Steel Radial Damper
3100-2 - Fixed	10	10" round	Optional			G3	Round Equalizing Grid
3100A-2 - Adjustable	12	12" round	02 - Aluminum			GD3	Combo Grid/Damper
	14	14" round	24 - Mill			BDS	Butterfly Damper
	16	16" round	03 - Black			RSD	Radial Shutter Damper
	18	18" round	28 - Custom Color				
	20	20" round					
	24	24" round					
	30	30" round					
	36	36" round					

30" and 36" units are available in non-adjustable aluminum models only

### Fixed/Adjustable Round Diffuser - 2 Cone

#### Series 3100S - Steel

Model	Available Neck Sizes		Available Finishes	Available Options		Available Accessories	
3100S-1 - Fixed	6	6" round	Standard	SC	Safety Chain	D3	Aluminum Radial Damper
3100S-A-1 - Adjustable	8	8" round	01 - White			SD3	Steel Radial Damper
3100S-2 - Fixed	10	10" round	Optional			G3	Round Equalizing Grid
3100S-A-2 - Adjustable	12	12" round	02 - Aluminum			GD3	Combo Grid/Damper
	14	14" round	03 - Black			BDS	Butterfly Damper
	16	16" round	28 - Custom Color			RSD	Radial Shutter Damper
	18	18" round					
	20	20" round					
	24	24" round					

# RCD - Round Ceiling Diffusers

8/2006

## Adjustable Round Diffusers Model 3200 Steel

### Product Details

- ✦ Excellent choice for high capacity applications such as factories, gymnasiums, theaters, and convention halls
- ✦ Discharge pattern is easily adjusted from vertical to horizontal with adjustment ring
- ✦ Diffuser can effectively be applied for either spot heating or cooling
- ✦ In the horizontal setting the unit provides tight ceiling patterns excellent for VAV applications
- ✦ Outer cone design guards against ceiling smudging in horizontal position



**Model 3200-1**

Standard Finish: 01 White

Dimensions are in inches

Round Diffuser - High Capacity - Adjustable - Pole Operated - Vertical to Horizontal Pattern  
Model 3200-1

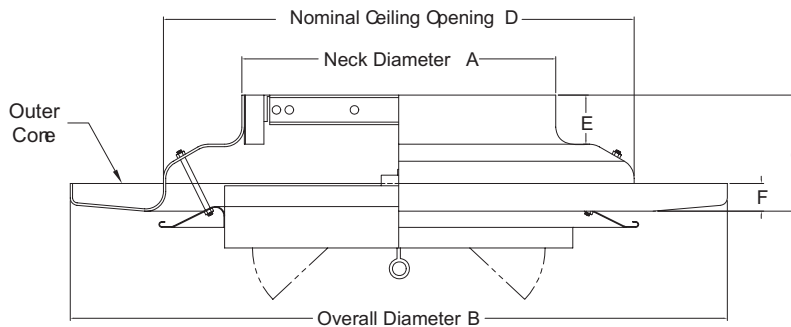

Dimensions						
Size	A	B	C	D	E	F
6	5 3/4	17 1/4	2 1/8	6 3/4	1 1/8	1 1/8
8	7 3/4	17 1/4	2 1/8	8 3/4	1 1/8	1 1/4
10	9 3/4	20 1/4	2 5/8	10 3/4	1 1/4	1 3/4
12	11 3/4	22 1/4	2 5/8	12 3/4	1 1/4	1 3/4
14	13 3/4	29 1/2	2 5/8	14 3/4	1 1/4	2 3/8
16	15 3/4	29 1/2	2 3/4	16 3/4	1 1/4	2 3/8
18	17 3/4	33 1/2	3 5/8	18 3/4	1 1/4	2 1/2
20	19 3/4	36 1/2	3 5/8	20 3/4	1	2 1/2
24	23 3/4	40 1/2	3 5/8	24 3/4	1	2 1/2

1. Available Finishes	2. Available Accessories	3. Available Options	4. Construction Details
Standard Finish: 01 White Optional Finish 02 Aluminum paint 03 Black 24 Mill finish 28 Custom color	G3 - Equalizing Grid . . . . . 337	Safety Chain	• Sizes only as listed • Units 14" and greater are shipped with a factory installed safety chain

# RCD - Round Ceiling Diffusers

## Model 3200 - Performance

Neck Velocity		400	500	600	700	800	900	1000	1200	1400	1600
Velocity Pressure		0.010	0.016	0.022	0.031	0.040	0.050	0.062	0.090	0.122	0.160
6" Dia	Air Flow Rate, CFM	80	100	120	135	155	175	195	235	275	315
	Static Pressure, H	<b>0.004</b>	<b>0.007</b>	<b>0.010</b>	<b>0.013</b>	<b>0.017</b>	<b>0.022</b>	<b>0.027</b>	<b>0.039</b>	<b>0.052</b>	<b>0.069</b>
	Total Pressure, H	0.014	0.022	0.032	0.044	0.057	0.072	0.089	0.128	0.175	0.228
	Static Pressure, V	<b>0.020</b>	<b>0.032</b>	<b>0.046</b>	<b>0.062</b>	<b>0.081</b>	<b>0.103</b>	<b>0.127</b>	<b>0.182</b>	<b>0.248</b>	<b>0.324</b>
	Total Pressure, V	0.030	0.047	0.068	0.093	0.121	0.153	0.189	0.272	0.371	0.484
	NC, H	<	<	15	16	17	19	21	24	26	29
	NC, V	<	<	<	13	15	16	18	22	25	29
	Throw, H, cooling	1-1-3	1-2-3	1-2-4	1-2-4	2-2-5	2-3-6	2-3-6	2-4-7	3-4-9	3-5-9
	Throw, V, cooling	2-4-8	4-5-11	4-6-13	5-7-14	5-8-16	6-9-19	7-10-21	8-12-25	10-15-29	11-17-33
	Throw, V, heating	0-1-3	1-2-4	1-2-4	1-2-5	2-3-6	2-3-6	2-4-7	3-4-8	3-5-10	4-6-11
8" Dia	Air Flow Rate, CFM	140	175	210	245	280	315	350	420	490	560
	Static Pressure, H	<b>0.003</b>	<b>0.004</b>	<b>0.006</b>	<b>0.009</b>	<b>0.011</b>	<b>0.014</b>	<b>0.018</b>	<b>0.026</b>	<b>0.035</b>	<b>0.046</b>
	Total Pressure, H	0.013	0.020	0.029	0.039	0.051	0.065	0.080	0.115	0.157	0.205
	Static Pressure, V	<b>0.012</b>	<b>0.018</b>	<b>0.026</b>	<b>0.036</b>	<b>0.046</b>	<b>0.059</b>	<b>0.073</b>	<b>0.104</b>	<b>0.142</b>	<b>0.186</b>
	Total Pressure, V	0.022	0.034	0.049	0.066	0.086	0.109	0.135	0.194	0.264	0.345
	NC, H	<	16	18	20	21	23	25	28	31	34
	NC, V	<	<	<	<	<	17	19	24	28	32
	Throw, H, cooling	1-2-3	1-2-4	2-2-5	2-3-6	2-3-7	2-4-7	3-4-8	3-5-10	4-6-12	4-7-12
	Throw, V, cooling	3-6-11	5-7-14	6-8-17	8-10-19	7-11-22	8-13-25	9-14-28	11-17-33	13-19-39	15-22-45
	Throw, V, heating	1-1-4	1-2-5	1-3-6	2-3-7	3-4-8	3-4-9	3-5-9	4-6-11	4-7-13	5-8-15
10" Dia	Air Flow Rate, CFM	220	275	325	380	435	490	545	655	765	875
	Static Pressure, H	<b>0.003</b>	<b>0.004</b>	<b>0.006</b>	<b>0.009</b>	<b>0.011</b>	<b>0.014</b>	<b>0.018</b>	<b>0.026</b>	<b>0.035</b>	<b>0.046</b>
	Total Pressure, H	0.013	0.020	0.029	0.039	0.051	0.065	0.080	0.115	0.157	0.205
	Static Pressure, V	<b>0.012</b>	<b>0.018</b>	<b>0.026</b>	<b>0.036</b>	<b>0.046</b>	<b>0.059</b>	<b>0.073</b>	<b>0.104</b>	<b>0.142</b>	<b>0.186</b>
	Total Pressure, V	0.022	0.034	0.049	0.066	0.086	0.109	0.135	0.194	0.264	0.345
	NC, H	<	16	17	19	20	22	23	26	29	32
	NC, V	<	<	<	<	<	15	17	23	27	31
	Throw, H, cooling	1-2-4	2-3-5	2-3-6	2-4-7	3-4-8	3-5-9	3-5-10	4-6-12	5-7-14	6-8-15
	Throw, V, cooling	4-7-14	6-9-18	7-10-21	8-12-24	9-14-28	10-16-31	12-17-35	14-21-42	16-24-49	19-28-56
	Throw, V, heating	1-2-5	1-3-6	2-4-7	2-4-8	3-5-9	4-5-11	4-6-12	5-7-14	6-8-17	6-9-19
12" Dia	Air Flow Rate, CFM	315	395	470	550	630	705	785	940	1100	1255
	Static Pressure, H	<b>0.003</b>	<b>0.004</b>	<b>0.006</b>	<b>0.009</b>	<b>0.011</b>	<b>0.014</b>	<b>0.018</b>	<b>0.026</b>	<b>0.035</b>	<b>0.046</b>
	Total Pressure, H	0.013	0.020	0.029	0.039	0.051	0.065	0.080	0.115	0.157	0.205
	Static Pressure, V	<b>0.011</b>	<b>0.017</b>	<b>0.025</b>	<b>0.034</b>	<b>0.044</b>	<b>0.055</b>	<b>0.069</b>	<b>0.099</b>	<b>0.134</b>	<b>0.175</b>
	Total Pressure, V	0.021	0.033	0.047	0.064	0.084	0.106	0.131	0.188	0.257	0.335
	NC, H	<	15	17	19	23	26	29	35	40	43
	NC, V	<	<	<	17	20	23	27	32	37	41
	Throw, H, cooling	2-2-5	2-3-6	2-4-7	3-4-9	3-5-10	4-6-11	4-6-12	5-7-15	6-9-17	7-10-19
	Throw, V, cooling	4-8-17	7-10-21	8-12-25	10-15-29	11-17-33	12-19-37	14-21-42	17-25-50	19-29-58	22-33-67
	Throw, V, heating	1-2-6	1-3-7	2-4-8	3-5-10	4-6-11	4-6-13	5-7-14	6-8-17	7-10-20	8-11-23
14" Dia	Air Flow Rate, CFM	430	535	640	750	855	960	1070	1285	1495	1710
	Static Pressure, H	<b>0.003</b>	<b>0.004</b>	<b>0.006</b>	<b>0.009</b>	<b>0.011</b>	<b>0.014</b>	<b>0.018</b>	<b>0.026</b>	<b>0.035</b>	<b>0.046</b>
	Total Pressure, H	0.013	0.020	0.029	0.039	0.051	0.065	0.080	0.115	0.157	0.205
	Static Pressure, V	<b>0.011</b>	<b>0.017</b>	<b>0.024</b>	<b>0.033</b>	<b>0.043</b>	<b>0.055</b>	<b>0.068</b>	<b>0.097</b>	<b>0.133</b>	<b>0.173</b>
	Total Pressure, V	0.021	0.033	0.047	0.064	0.083	0.105	0.13	0.187	0.255	0.333
	NC, H	<	16	21	25	29	32	36	41	44	46
	NC, V	<	15	19	23	27	30	33	38	42	45
	Throw, H, cooling	2-3-6	2-4-7	3-4-9	3-5-10	4-6-12	4-6-13	5-7-14	6-9-17	7-10-20	8-12-22
	Throw, V, cooling	1-3-13	2-5-21	3-7-28	5-10-33	6-13-38	7-17-43	9-21-48	13-29-57	18-33-67	24-38-71
	Throw, V, heating	1-2-5	1-3-7	2-4-8	3-5-9	4-5-11	4-6-12	4-7-13	5-8-16	6-9-19	7-11-22
16" Dia	Air Flow Rate, CFM	560	700	840	975	1115	1255	1395	1675	1955	2235
	Static Pressure, H	<b>0.003</b>	<b>0.004</b>	<b>0.006</b>	<b>0.009</b>	<b>0.011</b>	<b>0.014</b>	<b>0.018</b>	<b>0.026</b>	<b>0.035</b>	<b>0.046</b>
	Total Pressure, H	0.013	0.020	0.029	0.039	0.051	0.065	0.080	0.115	0.157	0.205
	Static Pressure, V	<b>0.010</b>	<b>0.016</b>	<b>0.024</b>	<b>0.032</b>	<b>0.042</b>	<b>0.053</b>	<b>0.066</b>	<b>0.094</b>	<b>0.129</b>	<b>0.168</b>
	Total Pressure, V	0.02	0.032	0.046	0.063	0.082	0.104	0.128	0.184	0.251	0.328
	NC, H	15	20	25	29	33	37	40	45	48	50
	NC, V	16	20	24	28	31	35	38	43	47	49
	Throw, H, cooling	2-3-7	3-4-8	3-5-10	4-6-12	4-7-13	5-7-15	6-8-17	7-10-20	8-12-23	9-13-25
	Throw, V, cooling	2-4-14	3-6-23	4-8-30	5-11-35	6-14-40	8-18-45	10-22-50	14-30-60	20-35-69	26-40-79
	Throw, V, heating	1-2-6	1-3-8	2-4-9	2-5-11	3-6-12	4-7-14	5-8-16	6-9-19	7-11-22	8-12-25

See Page RCD-24 for Performance Notes

Round Ceiling Diffusers  
RCD

# RCD - Round Ceiling Diffusers

## Model 3200 - Performance

Neck Velocity		400	500	600	700	800	900	1000	1200	1400	1600
Velocity Pressure		0.010	0.016	0.022	0.031	0.040	0.050	0.062	0.090	0.122	0.160
18" Dia	Air Flow Rate, CFM	705	885	1060	1235	1415	1590	1765	2120	2475	2825
	Static Pressure, H	<b>0.003</b>	<b>0.004</b>	<b>0.006</b>	<b>0.009</b>	<b>0.011</b>	<b>0.014</b>	<b>0.018</b>	<b>0.026</b>	<b>0.035</b>	<b>0.046</b>
	Total Pressure, H	0.013	0.02	0.029	0.039	0.051	0.065	0.08	0.115	0.157	0.205
	Static Pressure, V	<b>0.01</b>	<b>0.016</b>	<b>0.023</b>	<b>0.031</b>	<b>0.041</b>	<b>0.051</b>	<b>0.064</b>	<b>0.092</b>	<b>0.125</b>	<b>0.163</b>
	Total Pressure, V	0.02	0.031	0.045	0.062	0.081	0.102	0.126	0.181	0.247	0.322
	NC, H	<	<b>19</b>	<b>23</b>	<b>27</b>	<b>31</b>	<b>35</b>	<b>38</b>	<b>44</b>	<b>50</b>	<b>54</b>
	NC, V	<	16	21	25	30	34	37	43	49	52
	Throw, H, cooling	<b>2-4-7</b>	<b>3-5-9</b>	<b>4-6-11</b>	<b>4-7-13</b>	<b>5-7-15</b>	<b>6-8-17</b>	<b>6-9-19</b>	<b>7-11-22</b>	<b>9-13-26</b>	<b>10-15-28</b>
	Throw, V, cooling	2-4-14	3-6-23	4-8-32	5-11-37	6-14-43	8-18-48	10-23-53	14-32-64	20-37-74	26-43-85
	Throw, V, heating	<b>1-1-5</b>	<b>1-2-8</b>	<b>1-3-11</b>	<b>2-4-12</b>	<b>2-5-14</b>	<b>3-6-16</b>	<b>4-8-18</b>	<b>5-11-21</b>	<b>7-12-25</b>	<b>9-14-28</b>
20" Dia	Air Flow Rate, CFM	875	1090	1310	1525	1745	1965	2180	2620	3055	3490
	Static Pressure, H	<b>0.003</b>	<b>0.004</b>	<b>0.006</b>	<b>0.009</b>	<b>0.011</b>	<b>0.014</b>	<b>0.018</b>	<b>0.026</b>	<b>0.035</b>	<b>0.046</b>
	Total Pressure, H	0.013	0.02	0.029	0.039	0.051	0.065	0.08	0.115	0.157	0.205
	Static Pressure, V	<b>0.01</b>	<b>0.015</b>	<b>0.022</b>	<b>0.029</b>	<b>0.038</b>	<b>0.049</b>	<b>0.06</b>	<b>0.087</b>	<b>0.118</b>	<b>0.154</b>
	Total Pressure, V	0.02	0.031	0.044	0.06	0.078	0.099	0.123	0.176	0.24	0.314
	NC, H	<	<b>19</b>	<b>25</b>	<b>29</b>	<b>34</b>	<b>38</b>	<b>41</b>	<b>48</b>	<b>53</b>	<b>57</b>
	NC, V	<	<	20	25	30	35	39	45	50	52
	Throw, H, cooling	<b>3-4-8</b>	<b>3-5-10</b>	<b>4-6-12</b>	<b>5-7-14</b>	<b>6-8-17</b>	<b>6-9-19</b>	<b>7-10-21</b>	<b>8-12-25</b>	<b>10-14-29</b>	<b>11-17-31</b>
	Throw, V, cooling	2-4-14	2-6-22	4-8-32	5-11-41	6-14-47	8-18-53	10-22-59	14-32-71	19-41-83	25-47-95
	Throw, V, heating	<b>0-1-4</b>	<b>1-1-6</b>	<b>1-2-9</b>	<b>1-3-12</b>	<b>2-4-15</b>	<b>2-5-18</b>	<b>3-6-19</b>	<b>4-9-23</b>	<b>5-12-27</b>	<b>7-15-31</b>
24" Dia	Air Flow Rate, CFM	1255	1570	1885	2200	2515	2825	3140	3770	4400	5025
	Static Pressure, H	<b>0.002</b>	<b>0.004</b>	<b>0.005</b>	<b>0.007</b>	<b>0.009</b>	<b>0.012</b>	<b>0.015</b>	<b>0.021</b>	<b>0.029</b>	<b>0.038</b>
	Total Pressure, H	0.012	0.019	0.028	0.038	0.049	0.062	0.077	0.111	0.151	0.197
	Static Pressure, V	<b>0.009</b>	<b>0.014</b>	<b>0.021</b>	<b>0.028</b>	<b>0.037</b>	<b>0.047</b>	<b>0.058</b>	<b>0.083</b>	<b>0.113</b>	<b>0.148</b>
	Total Pressure, V	0.019	0.03	0.043	0.059	0.077	0.097	0.12	0.173	0.236	0.308
	NC, H	<	<b>19</b>	<b>25</b>	<b>31</b>	<b>36</b>	<b>40</b>	<b>44</b>	<b>50</b>	<b>54</b>	<b>56</b>
	NC, V	<	17	23	28	32	37	40	47	52	56
	Throw, H, cooling	<b>3-5-10</b>	<b>4-6-12</b>	<b>5-7-15</b>	<b>6-9-17</b>	<b>7-10-20</b>	<b>7-11-22</b>	<b>8-12-25</b>	<b>10-15-30</b>	<b>12-17-35</b>	<b>13-20-37</b>
	Throw, V, cooling	2-4-17	3-7-27	4-10-38	6-13-50	8-17-57	10-21-64	12-27-71	17-38-85	23-50-99	30-57-109
	Throw, V, heating	<b>1-1-5</b>	<b>1-2-7</b>	<b>1-3-10</b>	<b>2-3-14</b>	<b>2-5-18</b>	<b>3-6-21</b>	<b>3-7-23</b>	<b>5-10-28</b>	<b>6-14-33</b>	<b>8-18-37</b>

### Performance Notes for Model 3200-1:

1. Tabulated throw in feet is based on a 9' ceiling, with supply air temperature 20°F cooler than room temperature, heating air temperature is 20°F above room temperature MAX Throw @ Vt = 50 fpm, MIN Throw @ Vt = 150 fpm, and the diffuser/inner cones in down position for 360° horizontal air distribution pattern.

Example: 9-13-27

.....Distance @ 50 fpm Term. Vel.  
 .....Distance @ 100 fpm Term. Vel.  
 .....Distance @ 150 fpm Term. Vel.

2. Velocity Pressure (Pv) and Static Pressure (Ps) are in inches of water. Pv + Ps = Pt (total pressure).
3. Series 3200 Round Adjustable Diffusers are tested in accordance with ASHRAE 70-1991. Sound data are calculated in accordance with International Standard ISO 3741 comparison method. The NC values are based on a room absorption of 10 dB for sound power level (Lw) RE: 10E-12 watts. < symbol indicates NC less than 15. The NC data is for a single diffusers; for results of throttling a volume damper, see table below.
4. All data is applicable for exposed duct mounting or ceiling installation.



## Model 3200 - Specifications

Air outlets shall be model 3200 manufactured by METALAIRE®. Diffusers shall be constructed of an opposed blade damper inner assembly mounted in an inner ring. Outlets shall allow the adjustment of the discharge pattern from full horizontal to full vertical and be adjustable from the face by turning an operator ring. Units shall be steel construction. The units shall be the size and quantity as outline in the plans and specifications.

Pattern adjustment operator shall open the inner opposed blade damper assembly to discharge the air in a vertical pattern or close the damper to allow a tight horizontal pattern. In the horizontal setting, core shall project discharge pattern to minimize ceiling smudging. The inner core assembly shall be removable for installation and for access into the ductwork.

### Performance Specification

The manufacturer shall provide published performance data. Data shall be tested in accordance to ANSI/ASHRAE Standard 70-1991.

### Paint Specification

Process shall be anodic electrodeposition using an anodic acrylic paint. Units shall undergo pre-treatment including a pressurized spray stage using an alkaine cleaner and a de-ionized water rinse.

Film Properties shall meet or exceed the following standards:

Property	Test Method	Performance
Film thickness		.8-1.0 mils
Film Cure		320 F @ 20 min
Gloss – 60 deg.	ASTM D523-89	70-80%
Pencil Hardness	ASTM D3363-92A	HB-H
Crosshatch Adhesion	ASTM D3359-95	4B-5B
Direct Impact	ASTM D2794-93	100 in.lbs. Min
Reverse Impact	ASTM D2794-93	60 in.lbs. Min.
Salt Spray	ASTM B117-95	48-96 Hours
Humidity	ASTM D1735-92	500 Hours
Water Soak	ASTM D870-92	250 Hours

## Model 3200 - Model Specification Guide

### Adjustable - Round Ceiling Diffuser

#### Face Accessible Operating Ring

#### Steel - Center Opposed Blade Damper

Model	Available Neck Sizes		Available Finishes	Available Options		Available Accessories	
3200-1 - Adjustable	6	6" round	Standard	SC	Safety Chain	G3	Round Equalizing Grid
	8	8" round	01 - White				
	10	10" round	Optional				
	12	12" round	02 - Aluminum				
	14	14" round	03 - Black				
	16	16" round	28 - Custom Color				
	18	18" round					
	20	20" round					
	24	24" round					

# RCD - Round Ceiling Diffusers

8/2006

Round Ceiling Diffusers



RCD

- ➔ Round Architectural Diffusers ➔ Model R5750 ➔ All Aluminum
- ➔ Model R5750-AF ➔ Aluminum Face/Steel Backpan
- ➔ Model R5750-S ➔ All Steel

## Product Details

- ★ Architectural pleasing round diffuser blends well into the ceiling surface
- ★ Fixed horizontal throw pattern
- ★ Designed for surface mounting applications
- ★ Excellent in both heating and cooling applications
- ★ The R5750 is an excellent choice for VAV applications



**Model R5750**

Standard Finish: 01 White

Dimensions are in inches

## Round Diffusers

### Aluminum / Steel Construction - Fixed Horizontal Pattern

Model R5750-S - All Steel Construction

Model R5750-AL - All Aluminum Construction

Model R5750-AF - Steel Backpan - Aluminum Face

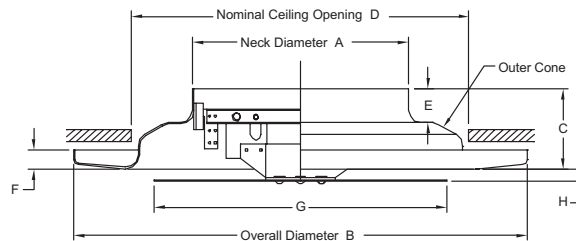

Nominal Round Duct Size	Dim. A	Dim. B	Dim. C	Dim. D	Dim. E	Dim. F	Dim. G	Dim. H
6	5 3/4	16 5/8	2 15/16	11	3/4	5/8	9	3/4
8	7 3/4	16 5/8	2 15/16	11	3/4	5/8	9	3/4
10	9 3/4	22 3/16	3 5/16	17	1.0	7/8	14	7/8
12	11 3/4	22 3/16	3 5/16	17	1.0	7/8	14	7/8
14	13 3/4	29 1/4	4 3/16	22	1.0	7/8	19	7/8
16	15 3/4	29 1/4	4 3/16	22	1.0	7/8	19	7/8

1. Available Finishes	2. Available Accessories	3. Available Options	4. Construction Details
<b>Standard Finish:</b> 01 White <b>Optional Finish</b> 02 Aluminum paint 03 Black 24 Mill finish 28 Custom color	D3 - Aluminum Radial Opposed Blade Damper . . .336 SD3 - Steel Radial Opposed Blade Damper . . . . .336 GD3 - Combination Grid/Damper . . . . .337 BDS - Steel Butterfly Damper . . . . .337 RSD - Radial Shutter Damper . . . . .336 G3 - Equalizing Grid . . . . .337	Safety Chain	• Sizes only as listed

## Model R5750 - Performance

Neck Size	Nk Velocity P <sub>v</sub>	400 0.015	500 0.024	600 0.034	700 0.046	800 0.060	900 0.076	1000 0.094	1200 0.136
6	CFM	79	98	118	137	157	177	196	236
	P <sub>s</sub>	<b>0.023</b>	<b>0.035</b>	<b>0.052</b>	<b>0.070</b>	<b>0.092</b>	<b>0.117</b>	<b>0.143</b>	<b>0.208</b>
	P <sub>t</sub>	0.038	0.059	0.086	0.116	0.152	0.193	0.237	0.344
	Throw NC	1 - 2 - 4 <b>&lt;15</b>	2 - 3 - 5 <b>&lt;15</b>	2 - 3 - 6 <b>19</b>	2 - 3 - 6 <b>24</b>	2 - 4 - 7 <b>29</b>	3 - 4 - 8 <b>31</b>	3 - 5 - 9 <b>34</b>	4 - 6 - 11 <b>38</b>
8	CFM	140	175	209	244	279	314	349	419
	P <sub>s</sub>	<b>0.024</b>	<b>0.037</b>	<b>0.054</b>	<b>0.074</b>	<b>0.096</b>	<b>0.122</b>	<b>0.150</b>	<b>0.216</b>
	P <sub>t</sub>	0.039	0.061	0.088	0.120	0.156	0.198	0.244	0.352
	Throw NC	1 - 2 - 4 <b>&lt;15</b>	2 - 3 - 6 <b>16</b>	2 - 3 - 7 <b>21</b>	3 - 4 - 8 <b>26</b>	3 - 4 - 9 <b>31</b>	3 - 5 - 10 <b>33</b>	4 - 6 - 11 <b>35</b>	4 - 7 - 13 <b>40</b>
10	CFM	218	273	327	382	436	491	545	654
	P <sub>s</sub>	<b>0.026</b>	<b>0.040</b>	<b>0.058</b>	<b>0.080</b>	<b>0.104</b>	<b>0.132</b>	<b>0.162</b>	<b>0.233</b>
	P <sub>t</sub>	0.041	0.064	0.092	0.126	0.164	0.208	0.256	0.369
	Throw NC	3 - 4 - 7 <b>&lt;15</b>	4 - 6 - 9 <b>&lt;15</b>	4 - 7 - 11 <b>&lt;15</b>	5 - 8 - 13 <b>24</b>	6 - 9 - 14 <b>28</b>	7 - 10 - 16 <b>32</b>	7 - 11 - 18 <b>35</b>	9 - 13 - 21 <b>41</b>
12	CFM	314	393	471	550	628	707	785	942
	P <sub>s</sub>	<b>0.035</b>	<b>0.054</b>	<b>0.078</b>	<b>0.106</b>	<b>0.139</b>	<b>0.175</b>	<b>0.216</b>	<b>0.311</b>
	P <sub>t</sub>	0.050	0.078	0.112	0.152	0.199	0.251	0.310	0.447
	Throw NC	4 - 5 - 11 <b>&lt;15</b>	4 - 7 - 12 <b>&lt;15</b>	5 - 8 - 13 <b>&lt;15</b>	6 - 9 - 14 <b>26</b>	7 - 11 - 16 <b>29</b>	8 - 12 - 19 <b>34</b>	9 - 13 - 21 <b>36</b>	11 - 16 - 22 <b>43</b>
14	CFM	428	535	641	748	855	962	1069	1283
	P <sub>s</sub>	<b>0.025</b>	<b>0.038</b>	<b>0.055</b>	<b>0.075</b>	<b>0.098</b>	<b>0.124</b>	<b>0.153</b>	<b>0.220</b>
	P <sub>t</sub>	0.040	0.062	0.089	0.121	0.158	0.200	0.247	0.356
	Throw NC	4 - 6 - 12 <b>&lt;15</b>	5 - 7 - 12 <b>&lt;15</b>	6 - 9 - 13 <b>22</b>	7 - 10 - 16 <b>23</b>	8 - 12 - 17 <b>25</b>	9 - 13 - 19 <b>26</b>	10 - 15 - 21 <b>29</b>	12 - 18 - 21 <b>33</b>
16	CFM	559	698	838	977	1117	1257	1396	1676
	P <sub>s</sub>	<b>0.038</b>	<b>0.058</b>	<b>0.084</b>	<b>0.114</b>	<b>0.149</b>	<b>0.187</b>	<b>0.230</b>	<b>0.328</b>
	P <sub>t</sub>	0.053	0.082	0.118	0.160	0.209	0.263	0.324	0.464
	Throw NC	4 - 7 - 13 <b>19</b>	6 - 8 - 13 <b>19</b>	7 - 10 - 15 <b>24</b>	8 - 12 - 18 <b>26</b>	9 - 13 - 19 <b>32</b>	10 - 15 - 21 <b>33</b>	11 - 17 - 23 <b>34</b>	13 - 20 - 24 <b>37</b>

### Performance Notes:

All data are tested in accordance with ANSI/ASHRAE 70-1991

### Definition of Units:

- CFM - Cubic feet per minute (air)
- Nk Vel - Neck velocity of air stream in feet per minute
- P<sub>v</sub> - Velocity pressure (inches of water column)
- P<sub>t</sub> - Total pressure (inches of water column)
- P<sub>s</sub> - Static pressure = P<sub>t</sub> - P<sub>v</sub> (inches of water column)
- Throw - Isothermal horizontal throw (supply air temperature the same as average room air temperature) values are for 150 fpm - 100 fpm - 50 fpm velocities, respectively
- NC - Noise criterion, sound pressure level. NC ratings are based on sound power level (L<sub>w</sub>) RE: 10E-12 watts minus a 10 dB room attenuation in all octave bands





## Model R5750 - Specifications

Air outlets shall be model R5750-AL (all aluminum), R5750-AF (aluminum face, steel backpan) or R5750-S (all steel) manufactured by METALAIRE. Diffuser shall be constructed of a round flat face panel and a round outer cone. Outlet shall have a fixed horizontal pattern. The units shall be the size and quantity as outlined in the plans and specifications.

Round face panel shall be removable to allow access to the round outer cone. Outlet shall be designed for surface mounting applications and have an outer cone that allows flush mounting to the ceiling opening.

### Performance Specification

The manufacturer shall provide published performance data. Data shall be tested in accordance to ANSI/ASHRAE Standard 70-1991.

### Paint Specification

Process shall be anodic electrodeposition using an anodic acrylic paint. Units shall undergo pre-treatment including a pressurized spray stage using an alkaine cleaner and a de-ionized water rinse.

Film Properties shall meet or exceed the following standards:

Property	Test Method	Performance
Film thickness		.8-1.0 mils
Film Cure		320 F @ 20 min
Gloss – 60 deg.	ASTM D523-89	70-80%
Pencil Hardness	ASTM D3363-92A	HB-H
Crosshatch Adhesion	ASTM D3359-95	4B-5B
Direct Impact	ASTM D2794-93	100 in.lbs. Min
Reverse Impact	ASTM D2794-93	60 in.lbs. Min.
Salt Spray	ASTM B117-95	48-96 Hours
Humidity	ASTM D1735-92	500 Hours
Water Soak	ASTM D870-92	250 Hours

## Model R5750 - Model Specification Guide

Aluminum

Steel

Round Panel Faced Diffusers

Model	Available Neck Sizes		Available Finishes	Available Options		Available Accessories	
R5750-AL	6	6" round	Standard	SC	Safety Chain	D3	Aluminum Radial Damper
R5750-S	8	8" round	01 - White			SD3	Aluminum Radial Damper
	10	10" round	Optional			G3	Aluminum Radial Damper
	12	12" round	02 - Aluminum			GD3	Aluminum Radial Damper
	14	14" round	03 - Black			BDS	Aluminum Radial Damper
	16	16" round	28 - Custom Color			RSD	Aluminum Radial Damper



D  
C  
D

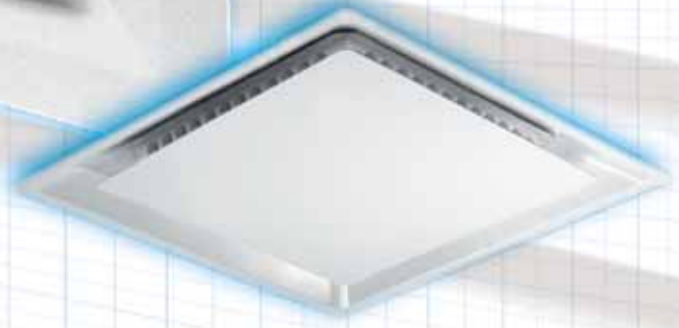
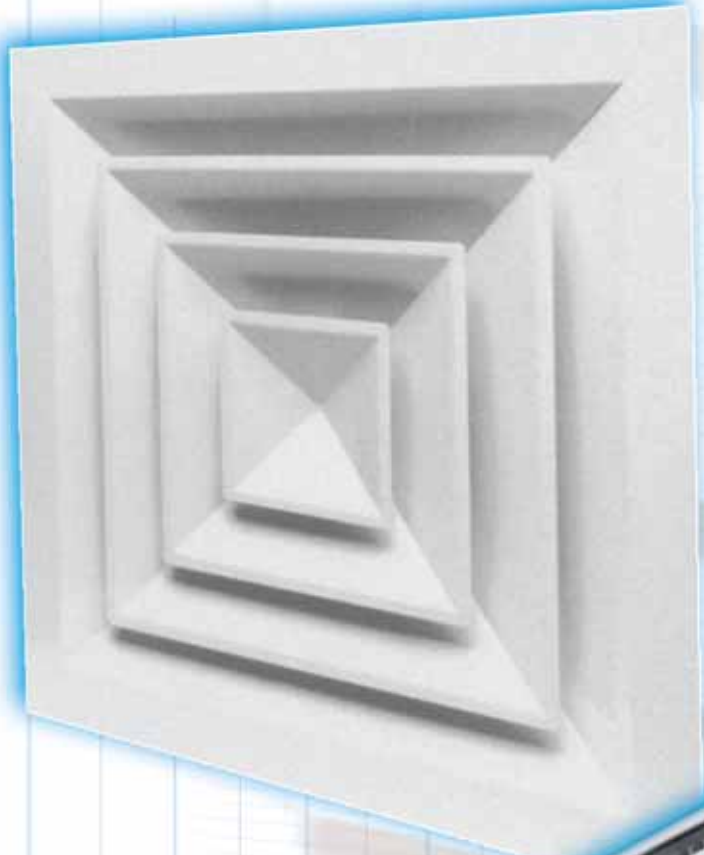

**DIRECTIONAL  
CEILING DIFFUSERS**

DIRECTIONAL  
CEILING DIFFUSERS



**Model 5000**  
Aluminum  
(Border 1  
Surface Mount Shown)  
Pg. 34



## Square/Rectangular Louver Face Ceiling Diffusers - Aluminum - Series 5000

- ★ Available in 1-way, 2-way opposite, 2-way corner, 3-way, and 4-way directional air patterns
- ★ Cores are easy to remove with spring loaded latches — no tools required
- ★ Series 5000 deflector blades are straight and do not include a horizontal lip, making this diffuser an excellent choice for high capacity applications
- ★ The series 5000 is an excellent choice for VAV applications
- ★ The series 5000 is available with optional induction vanes

Available Border Styles	
5000-1 Surface Mount	5000-6 T-bar Lay-in
5000-2 V-Beveled Drop Surface Mounting	5000-7 Concealed T-bar
5000-4 Drop Face Surface Mount	5000-8 Tegular T-bar
5000-46 Drop Face T-bar Lay-in	5000-9 Donn Finline



**Model 5500**  
Aluminum  
(Border 6  
T-bar Lay-in Shown)  
Pg. 46



## Square/Rectangular Louver Face Ceiling Diffusers - Aluminum - Series 5500

- ★ Available in 1-way, 2-way opposite, 2-way corner, 3-way, and 4-way directional air patterns
- ★ Cores are easy to remove with spring loaded latches — no tools required
- ★ Series 5500 deflector blades include a horizontal lip, making this diffuser an excellent choice for high induction applications
- ★ The series 5500 is an excellent choice for VAV applications
- ★ The series 5500 is available with optional induction vanes

Available Border Styles	
5500-1 Surface Mount	5500-6 T-bar Lay-in
5500-2 V-Beveled Drop Surface Mounting	5500-7 Concealed T-bar
5500-4 Drop Face Surface Mount	5500-8 Tegular T-bar
5500-46 Drop Face T-bar Lay-in	5500-9 Donn Finline



**Model 5500S**  
Steel  
(Border 6  
T-bar Lay-in Shown)  
Pg. 48



## Square/Rectangular Louver Face Ceiling Diffusers - Steel - Series 5500S

- ★ Available in 1-way, 2-way opposite, 2-way corner, 3-way, and 4-way directional air patterns
- ★ Cores are easy to remove with spring loaded latches — no tools required
- ★ Series 5500S deflector blades include a horizontal lip, making this diffuser an excellent choice for high induction applications
- ★ The series 5500S is an excellent choice for VAV applications
- ★ The series 5500S is also available with optional induction vanes.

Available Border Styles	
5500S-1 Surface Mount	5500SR-1 Flush Mount w/Integral Round Neck
5500S-2 V-Beveled Drop Surface Mounting	5500SR-2 V-Beveled Drop Surface Mounting - Round Neck
5500S-6 T-bar Lay-in	5500SR-6 T-bar Lay-in w/Integral Round Neck
5500S-8 Tegular T-bar	5500SR-8 Tegular T-bar - Round Neck
5500S-9 Donn Finline	5500SR-9 Donn Finline - Round Neck



**Model 5200**  
Pg. 58

## Square/Rectangular Diffusers - Economical Square Diffusers - Aluminum - Series 5200

- ★ Removable core for concealed mounting
- ★ Optional built-in opposed blade damper
- ★ Available in 1 way, 2 way opposite, 2 way corner, 3 way, and 4 way directional air patterns

Available Border Styles	
5200-1 Surface Mount	
5200-2 Beveled Drop Surface Mounting	
5200-6 T-bar Lay-in	

# DCD - Directional Ceiling Diffusers



**Model 5700**  
Pg. 62

Series 5700 - Fixed  
Series 5700A - Adjustable

## Square Face Diffusers - Round Neck 2-Cone - Steel/Aluminum/Aluminized Steel Adjustable/Non-Adjustable - Series 5700

- ✦ The series 5700 provides a tight horizontal 360° discharge pattern for superior induction and occupant comfort
- ✦ Series 5700 can be converted in the field to a 3 cone diffuser with the addition of the optional Snap-58
- ✦ Lay-in border designed to be installed in standard 15/16" wide tees
- ✦ T-bar Lay-in border 6 can be used in surface mounting applications by adding optional T-bar plaster frame (TBPF)
- ✦ The series 5700 is an excellent choice for VAV applications

Steel	Aluminized Steel	Aluminum	Adjustable/Steel	Adjustable/Aluminized Steel	Adjustable/Aluminum
5700-1 Surface Mount	5700-1 AS Surface Mount	5700-1 AL Surface Mount	5700A-1 Surface Mount	5700A-1 AS Surface Mount	
5700-6 T-bar Lay-in	5700-6 AS T-bar Lay-in	5700-6 AL T-bar Lay-in	5700A-6 T-bar Lay-in	5700A-6 AS T-bar Lay-in	5700A-6 AL T-bar Lay-in
5700-6P T-bar Lay-in Panel			5700A-7 Concealed T-bar	5700A-7 AS Concealed T-bar	
5700-7 Concealed T-bar	5700-7 AS Concealed T-bar				
5700-9 Donn Finline	5700-9 AS Donn Finline				
Metric/Steel	Metric/Aluminized Steel	Metric/Aluminum			
M5700-6 T-bar Lay-in 600mm x 600mm	M5700-6 AS T-bar Lay-in 600mm x 600mm	M5700-6 AL T-bar Lay-in 600mm x 600mm			



**Model 5750**  
Pg. 68

## Square Panel Face Diffusers - Round Neck - Uni-Flo - Steel/Aluminized Steel - Series 5750

- ✦ Attractive single panel design blends well with all ceilings
- ✦ The series 5750 provides a tight 360° discharge pattern for superior induction and occupant comfort
- ✦ T-bar Lay-in border type 6 designed to be installed in standard 15/16" wide tees
- ✦ Border type 6 can be used in surface mounting applications by adding optional T-bar plaster frame (TBPF)
- ✦ Face panel is easy to remove without tools
- ✦ The series 5750 is an excellent choice for VAV applications

Steel	Aluminized Steel	Metric/Steel	Metric/Aluminized Steel
5750-1 Surface Mount	5750-1 AS Surface Mount	M5750-6 T-bar Lay-in - 600mm x 600mm	M5750-6 AS T-bar Lay-in - 600mm x 600mm
5750-6 T-bar Lay-in	5750-6 AS T-bar Lay-in		
5750-7 Concealed T-bar	5750-7 AS Concealed T-bar		
5750-9 Donn Finline	5750-9 AS Donn Finline		



**Model 5800**  
Pg. 74

Series 5800 - Fixed  
Series 5800A - Adjustable

## Square Face Diffusers - Round Neck 3-Cone - Steel/Aluminum/Aluminized Steel Adjustable/Non-Adjustable - Series 5800

- ✦ The series 5800 provides a tight 360° discharge pattern for superior induction and occupant comfort
- ✦ T-bar Lay-in border type 6 is designed to be installed in standard 15/16" wide tees
- ✦ border type 6 can be used in surface mounting applications by adding optional T-bar plaster frame (TBPF)
- ✦ The Series 5800 is an excellent choice for VAV applications

Steel	Aluminized Steel	Aluminum	Adjustable/Steel	Adjustable/Aluminized Steel
5800-1 Surface Mount	5800-1 AS Surface Mount	5800-1 AL Surface Mount	5800A-1 Surface Mount	5800A-1 AS Surface Mount
5800-6 T-bar Lay-in	5800-6 AS T-bar Lay-in	5800-6 AL T-bar Lay-in	5800A-6 T-bar Lay-in	5800A-6 AS T-bar Lay-in
5800-6P T-bar Lay-in Panel				
5800-7 Concealed T-bar	5800-7 AS Concealed T-bar			
Metric/Steel	Metric/Aluminized Steel	Metric/Aluminum		
M5800-6 T-bar Lay-in 600mm x 600mm	M5800-6 AS T-bar Lay-in 600mm x 600mm	M5800-6 AL T-bar Lay-in 600mm x 600mm		





**Series Phenomator®**  
Pg. 80

## Square Panel Face Diffusers - Round Neck - Ultra High Performance - Series Phenomator®

- ✦ The highest induction ratio of any commercial air diffuser available
- ✦ Excellent selection for providing exceptional comfort, especially in executive offices, conference rooms, and board rooms
- ✦ Can improve productivity by maintaining draft-free comfort in many applications
- ✦ Designed for applications calling for minimal temperature differences in a space
- ✦ Solves comfort problems in applications such as reception areas and entrance ways
- ✦ Diffuser can be applied in critical applications requiring minimal temperature gradients

Steel	Aluminized Steel	Metric/Steel	Metric/Aluminized Steel
Phenom-1 Surface Mount	Phenom-1 AS Surface Mount	M-Phenom-6 T-bar Lay-in - 600mm x 600mm	M-Phenom-6 AS T-bar Lay-in - 600mm x 600mm
Phenom-6 T-bar Lay-in	Phenom-6 AS T-bar Lay-in		
Phenom-7 Concealed T-bar	Phenom-7 AS Concealed T-bar		
Phenom-9 Donn Finline	Phenom-9 AS Donn Finline		



**Model 5500 DAF-CC5**  
Pg. 84

## Concentric Supply/Return Ceiling Diffusers - Louvered Face - Cube Core Series 5500 DAF-CC5

- ✦ 5500 DAF-CC5 concentric supply/return diffuser is designed for high capacity application
- ✦ Cube core return
- ✦ 4-way air patterns only
- ✦ Choice of 6 mounting frames
- ✦ Snap-in/out core - simplifies installation
- ✦ Sizes to handle full range of standard tonnage roof-top units
- ✦ Supply/Return plenums are by others

Available Border Styles
5500 DAF-CC5-1 Surface Mount
5500 DAF-CC5-2 V-Beveled Drop Surface Mounting
5500 DAF-CC5-4 Deep Drop Frame
5500 DAF-CC5-6 T-bar Lay-in
5500 DAF-CC5-7 Concealed T-bar
5500 DAF-CC5-8 Tegular T-bar Lay-in



**Model 9000**  
Pg. 94

## Square/Rectangular Diffusers - Modular Core - Supply - Extruded Aluminum - Series 9000 Mod-Flo

- ✦ The series 9000 is a directional ceiling diffuser available in a wide range of field capabilities
- ✦ Modular cores can be adjusted to obtain 1-way, 2-way opposite, 2-way corner, 3-way, and 4-way air patterns
- ✦ Cores are easy to remove with spring loaded latches - no tools required
- ✦ T-bar Lay-in border type 6 can be used in surface mounting applications by adding optional T-bar plaster frame (TBPf)
- ✦ The series 9000 is an excellent choice for VAV applications

Available Styles
9000-1 Surface Mount
9000-2 Beveled Frame
9000-6 T-bar Lay-in
9000-7 Concealed Spline
9000-8 Tegular T-bar
9000-9 Donn Finline

# LEADING THE INDUSTRY IN PRODUCT LITERATURE

With the choice of our Pre-Flite Catalog, Quick Select Catalog, InfoSource Catalog, InfoSource CD and our web site, [www.metalaire.com](http://www.metalaire.com), you pick the format for product information that best suits your air distribution design needs.

## Pre-Flite - Product Overview Catalog

The METALAIRES Pre-Flite catalog is a condensed reference guide containing concise listings of our entire product line including grilles, registers, diffusers, and air terminal units. This catalog can be used to help select the type of device, along with available border styles. The catalog includes photos of each model along with the features and model guide, a great tool when you are trying to select a device for your project.



## Quick Select Catalog - Air Distribution Selection Made Easy

The METALAIRES Quick Select Catalog is designed to save you time selecting air distribution equipment. This catalog is a compact version of our InfoSource Catalogs and includes drawings and performance for our most popular products. The Quick Select Catalog is broken into product types with each section beginning with a model summary that includes features and benefits of our products. To obtain product information not included in the Quick Select Catalog, simply go to our web site at [www.metalaire.com](http://www.metalaire.com).



## InfoSource Catalog Suite - Complete guide to Air Distribution Selection

The METALAIRES InfoSource Catalog suite is the leading product catalog in the industry. Included in these catalogs are the complete product listings, drawings, product features and benefits, product performance data, specifications, and model specifications. These catalogs are organized to make it quick and easy to find the information you are looking for.

### InfoSource Catalog Suite

- Ceiling Diffusers Catalog
- Grilles & Registers Catalog
- Air Terminal Unit Catalog
- Formations Catalog



## InfoSource CD

Our InfoSource CD has set the standard in the industry for air distribution product selection. This CD contains a complete library of all our catalogs and submittals along with our air terminal unit selection program.



## Web Site: [www.metalaire.com](http://www.metalaire.com)

METALAIRES leads the industry with a web site that contains all the product literature and performance data needed to design your air distribution system. Our web site includes all our submittals, catalogs, installation manuals, as well as as other valuable information to aid you in air distribution design.





# DCD - Directional Ceiling Diffusers

8/2006

## ➔ Square/Rectangular Louver Face ➔ Series 5000 ➔ Extruded Aluminum

### Product Details

- Available in 1, 2-way opposite, 2-way corner, 3, and 4-way directional air patterns
- Cores are easy to remove with spring loaded latches - no tools required
- 5000 series deflector blades are straight and do not include a horizontal lip, making this diffuser an excellent choice for high capacity applications
- The 5000 series is an excellent choice for VAV applications
- The 5000 series is available with optional induction vanes

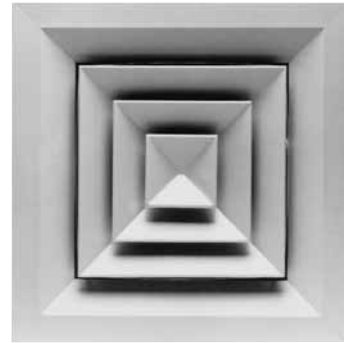

**Model 5000-1 S4 Shown**

Standard Finish: 01 White

Dimensions are in inches

### Square/Rectangular Louver Face Ceiling Diffusers Surface Mount - Removable Core Model 5000-1

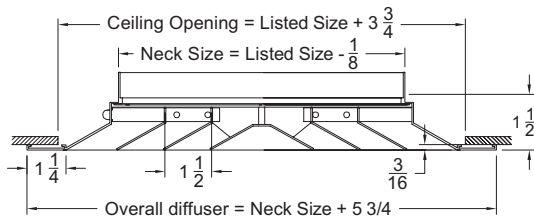

### Square/Rectangular Louver Face Ceiling Diffusers V-Beveled Drop Surface Mounting - Removable Core Model 5000-2

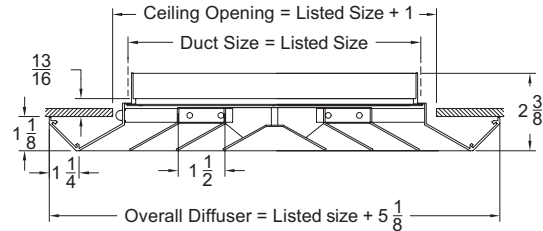

### Square/Rectangular Louver Face Ceiling Diffusers Drop Face Surface Mount - Removable Core Model 5000-4

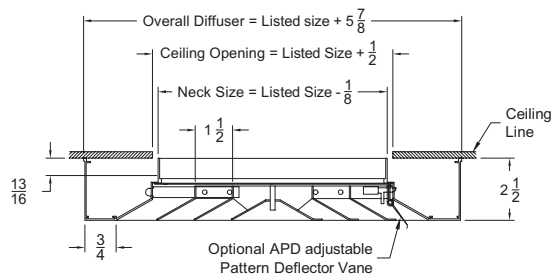

### Square/Rectangular Louver Face Ceiling Diffusers Drop Face - T-bar Lay-in - Removable Core Model 5000-46

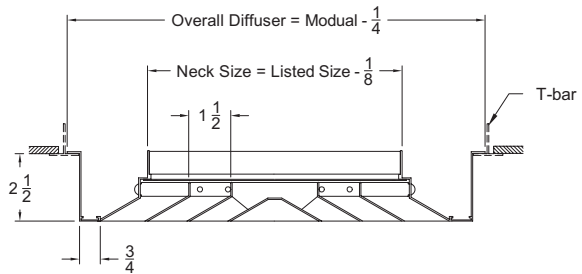

### Square/Rectangular Louver Face Ceiling Diffusers T-bar Lay-in - Removable Core Model 5000-6

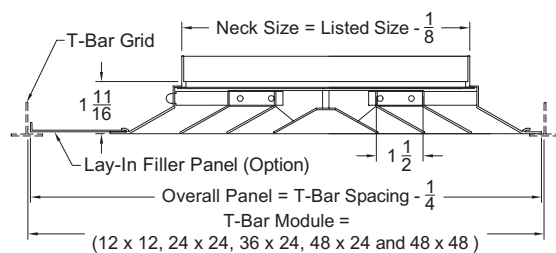

### Square/Rectangular Louver Face Ceiling Diffusers Concealed Spline - Removable Core Model 5000-7

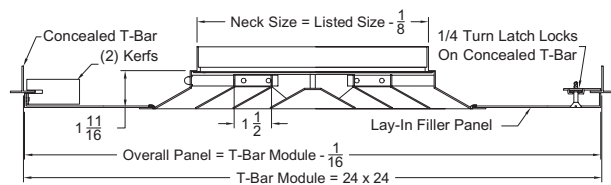

# DCD - Directional Ceiling Diffusers



**Square/Rectangular Louver Face Ceiling Diffusers**  
**Tegular T-bar - Removable Core**  
 Model 5000-8

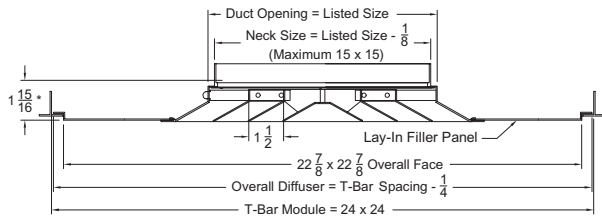

**Square/Rectangular Louver Face Ceiling Diffusers**  
**Donn Finline - Removable Core**  
 Model 5000-9

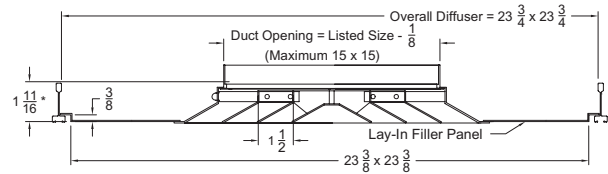

### Air Patterns - (Square) Louver Face Ceiling Diffusers

S1 - One Way	S2 - Two Way Opposite	SC - Two Way Corner	S3 - Three Way	S4 - Four Way

### Air Patterns - (Rectangular)

Short Louver Face Ceiling Diffusers				Long Louver Face Ceiling Diffusers		
R1 - One Way	R2S - Two Way Opposite	R3S - Three Way	R4 - Four Way	R1L - One Way	R2L - Two Way	R3L - Three Way

### Options and Accessories

**Square/Rectangular Louver Face Ceiling Diffusers**  
 Option: D5 Opposed Blade Damper

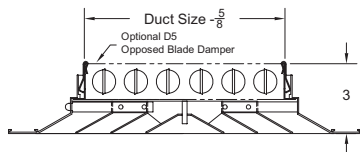

**Square/Rectangular Louver Face Ceiling Diffusers**  
 Option: IV Induction Vane (see page DCD-37 for performance)

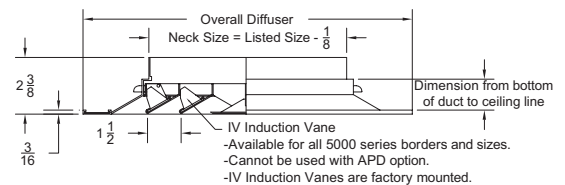

Option: APD Air Pattern Controller allows adjustment from horizontal to vertical from the face of the diffuser

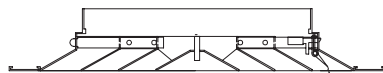

Optional APD Adjustable Pattern Deflector Vane  
 - Available for all 5000 series borders and sizes,  
 - Cannot be used with IV Induction Vanes option,  
 - APDs are factory mounted.

1. Available Finishes	2. Available Accessories	3. Available Options	4. Construction Details
<p><b>Standard Finish:</b>                      01 White</p> <p><b>Optional Finish</b>                      02 Aluminum paint                      03 Black                      24 Mill finish                      28 Custom color</p> <p><b>Note:</b>                      Anodized Finish not available</p>	<p><b>Square and Rectangular Neck:</b>                      D5 - Opposed Blade Damper- Steel .....337                      D5A - Opposed Blade Damper- Aluminum .....337                      L9 - Equalizing Grid .....334                      TR - Square to Round Transition .....338                      TR DEEP - Square to Round Transition - Deep .....338</p> <p><b>Round Neck:</b>                      G3 - Equalizing Grid .....337                      BDS - Butterfly Damper .....335                      RSD - Radial Shutter Damper .....336</p>	<p><b>Factory Mounted:</b>                      IV - Induction Vanes                      APD - Air Pattern Deflectors allows adjustment from horizontal to vertical air pattern from the face of the diffuser</p> <p><b>Note:</b>                      IV (Induction Vanes) can not be used with APD (Air Pattern Deflector) option and vice-versa</p>	<ul style="list-style-type: none"> <li>Available air patterns:                              S1, S2, S3, S4, R1S, R1L, R2S, R2L, R3S, R3L, R4 and SC</li> <li>For 5000-6 (D5) models only:                              21" x 21" neck in 24" x 24" module is available in S4 pattern only</li> </ul>

# DCD - Directional Ceiling Diffusers

8/2006

## Series 5000 - Performance/(S4) 4-Way Square Pattern

Models 5000 (-1, -2, -4, -46, -6, -7, -8, -9)

Directional Ceiling Diffusers



DCD

NECK SIZE Ak	Ps Pt	NECK VELOCITY					
		200	300	400	500	600	700
		.006 .008	.013 .018	.022 .032	.035 .050	.050 .072	.068 .099
6" X 6" Ak = .145	TOTAL CFM	50	75	100	125	150	175
	CFM/SIDE	13	19	25	31	38	44
	THROW	2-4	4-8	7-11	9-13	11-16	13-17
	NC	-	-	-	-	20	25
9" X 9" Ak = .325	TOTAL CFM	113	169	225	281	335	394
	CFM/SIDE	28	42	56	70	84	98
	THROW	3-5	5-9	8-12	10-15	12-17	14-18
	NC	-	-	-	21	26	31
12" X 12" Ak = .578	TOTAL CFM	200	300	400	500	600	700
	CFM/SIDE	50	75	100	125	150	175
	THROW	3-7	6-10	9-14	11-16	13-18	15-20
	NC	-	-	-	24	29	34
15" X 15" Ak = .903	TOTAL CFM	313	469	625	781	938	1094
	CFM/SIDE	78	117	156	195	234	273
	THROW	4-8	7-12	10-15	12-18	15-20	17-22
	NC	-	-	21	26	31	36
18" X 18" Ak = 1.301	TOTAL CFM	450	675	900	1125	1350	1575
	CFM/SIDE	113	169	225	281	338	394
	THROW	5-10	8-14	11-17	14-20	16-22	18-23
	NC	-	-	22	27	32	37
21" X 21" Ak = 1.77	TOTAL CFM	613	919	1225	1531	1837	2144
	CFM/SIDE	153	230	306	383	459	536
	THROW	6-12	9-16	12-19	15-21	17-23	19-25
	NC	-	-	23	28	33	38
24" X 24" Ak = 2.312	TOTAL CFM	800	1200	1600	2000	2400	2800
	CFM/SIDE	200	300	400	500	600	700
	THROW	7-14	10-17	13-20	16-23	18-25	21-27
	NC	-	-	24	29	34	39
27" X 27" Ak = 2.926	TOTAL CFM	1013	1519	2025	2531	3037	3544
	CFM/SIDE	253	380	506	633	759	886
	THROW	7-15	11-19	14-22	17-25	20-27	22-28
	NC	-	20	25	30	35	40
33" X 33" Ak = 4.371	TOTAL CFM	1513	2269	3025	3781	4537	5294
	CFM/SIDE	378	567	756	945	1134	1323
	THROW	9-18	13-22	16-25	19-27	22-30	24-31
	NC	-	21	26	31	36	41

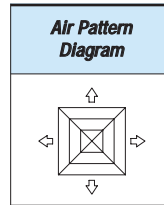

See Page DCD-43 for Performance Notes



# DCD - Directional Ceiling Diffusers

## Series 5000 - Performance/(R4) 4-Way Rectangular Pattern

Models 5000 (-1, -2, -4, -46, -6, -7, -8, -9)

NECK SIZE Ak	Ps Pt Side Designation	NECK VELOCITY											
		200		300		400		500		600		700	
		.006 .008		.013 .018		.022 .032		.035 .050		.050 .072		.068 .099	
		A	B	A	B	A	B	A	B	A	B	A	B
6" X 9" Ak = .217	TOTAL CFM	75		113		150		185		225		263	
	CFM/SIDE	13	25	19	38	25	50	31	63	38	75	43	86
6" X 12" Ak = .289	TOTAL CFM	100		150		200		250		300		350	
	CFM/SIDE	13	38	19	56	25	75	31	94	38	113	44	131
9" X 12" Ak = .434	TOTAL CFM	150		225		300		375		450		525	
	CFM/SIDE	28	47	42	70	56	94	70	117	84	141	98	164
9" X 15" Ak = .542	TOTAL CFM	188		281		375		469		563		656	
	CFM/SIDE	28	66	42	98	56	131	70	164	84	197	98	230
9" X 18" Ak = .650	TOTAL CFM	225		338		450		563		675		788	
	CFM/SIDE	28	84	42	127	56	169	70	211	84	253	98	295
9" X 21" Ak = .759	TOTAL CFM	263		394		525		656		788		919	
	CFM/SIDE	28	103	42	155	56	206	70	258	84	309	98	361
12" X 15" Ak = .723	TOTAL CFM	250		375		500		625		750		875	
	CFM/SIDE	50	75	75	113	100	150	125	188	150	225	175	263
12" X 18" Ak = .867	TOTAL CFM	300		450		600		750		900		1050	
	CFM/SIDE	50	100	75	150	100	200	125	250	150	300	175	350
12" X 21" Ak = 1.012	TOTAL CFM	350		525		700		875		1050		1225	
	CFM/SIDE	50	125	75	188	100	250	125	313	150	375	175	438
12" X 24" Ak = 1.156	TOTAL CFM	400		600		800		1000		1200		1400	
	CFM/SIDE	50	150	75	225	100	300	125	375	150	450	175	525
15" X 18" Ak = 1.084	TOTAL CFM	375		563		750		938		1125		1313	
	CFM/SIDE	78	109	117	164	156	219	195	273	234	328	273	383
15" X 24" Ak = 1.445	TOTAL CFM	500		750		1000		1250		1500		1750	
	CFM/SIDE	78	172	117	258	156	344	195	430	234	516	273	602
18" X 24" Ak = 1.734	TOTAL CFM	600		900		1200		1500		1800		2100	
	CFM/SIDE	113	188	160	281	225	375	281	469	338	563	394	656
21" X 33" Ak = 2.782	TOTAL CFM	963		1444		1925		2406		2888		3369	
	CFM/SIDE	153	328	230	492	306	656	383	820	459	984	536	1148
24" X 30" Ak = 2.890	TOTAL CFM	1000		1500		2000		2500		3000		3500	
	CFM/SIDE	200	300	300	450	400	600	500	750	600	900	700	1050

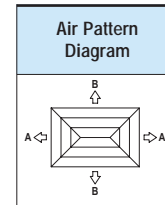

Directional Ceiling Diffusers



DCD

See Page DCD-43 for Performance Notes

# DCD - Directional Ceiling Diffusers

8/2006

## Series 5000 - Performance/(S3) 3-Way Square Pattern

Models 5000 (-1, -2, -4, -46, -6, -7, -8, -9)

Directional Ceiling Diffusers



DCD

NECK SIZE Ak	Ps Pt	NECK VELOCITY					
		200	300	400	500	600	700
		.006 .008	.013 .018	.022 .032	.035 .050	.050 .072	.068 .099
6" X 6" Ak = .135	TOTAL CFM	50	75	100	125	150	175
	CFM/SIDE	13	19	25	31	38	44
	THROW	2-4	4-8	7-11	9-13	11-16	13-17
	NC	-	-	-	-	20	25
9" X 9" Ak = .304	TOTAL CFM	113	169	225	281	335	394
	CFM/SIDE	28	42	56	70	84	98
	THROW	3-5	5-9	8-12	10-15	12-17	14-18
	NC	-	-	-	21	26	31
12" X 12" Ak = .541	TOTAL CFM	200	300	400	500	600	700
	CFM/SIDE	50	75	100	125	150	175
	THROW	3-7	6-10	9-14	11-16	13-18	15-20
	NC	-	-	-	24	29	34
15" X 15" Ak = .845	TOTAL CFM	313	469	625	781	938	1094
	CFM/SIDE	78	117	156	195	234	273
	THROW	4-8	7-12	10-15	12-18	15-20	17-22
	NC	-	-	21	26	31	36
18" X 18" Ak = 1.216	TOTAL CFM	450	675	900	1125	1350	1575
	CFM/SIDE	113	169	225	281	338	394
	THROW	5-10	8-14	11-17	14-20	16-22	18-23
	NC	-	-	22	27	32	37
21" X 21" Ak = 1.655	TOTAL CFM	613	919	1225	1531	1837	2144
	CFM/SIDE	153	230	306	383	459	536
	THROW	6-12	9-16	12-19	15-21	17-23	19-25
	NC	-	-	23	28	33	38
24" X 24" Ak = 2.162	TOTAL CFM	800	1200	1600	2000	2400	2800
	CFM/SIDE	200	300	400	500	600	700
	THROW	7-14	10-17	13-20	16-23	18-25	21-27
	NC	-	-	24	29	34	39
27" X 27" Ak = 2.736	TOTAL CFM	1013	1519	2025	2531	3037	3544
	CFM/SIDE	253	380	506	633	759	886
	THROW	7-15	11-19	14-22	17-25	20-27	22-28
	NC	-	20	25	30	35	40

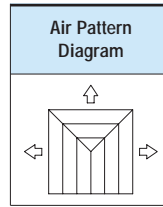

See Page DCD-43 for Performance Notes

# DCD - Directional Ceiling Diffusers

## Series 5000 - Performance/(R3L) 3-Way Rectangular Pattern

Models 5000 (-1, -2, -4, -46, -6, -7, -8, -9)

NECK SIZE Ak	Ps Pt Side Designation	NECK VELOCITY											
		200		300		400		500		600		700	
		.006 .008		.013 .018		.022 .032		.035 .050		.050 .072		.068 .099	
		A	B	A	B	A	B	A	B	A	B	A	B
6" X 9" Ak = .217	TOTAL CFM CFM/SIDE THROW NC	75 25 13 2-5 2-4 -	113 38 19 5-9 4-8 -	150 50 25 8-12 7-11 -	188 63 31 10-14 9-13 -	225 75 38 12-17 11-16 23	263 88 44 14-18 13-17 28						
6" X 12" Ak = .289	TOTAL CFM CFM/SIDE THROW NC	100 44 13 3-6 2-4 20	150 66 19 6-10 4-8 20	200 88 25 8-13 7-11 20	250 109 31 11-16 9-13 20	300 131 38 13-18 12-17 25	350 153 44 15-20 13-17 30						
9" X 12" Ak = .434	TOTAL CFM CFM/SIDE THROW NC	150 61 28 4-7 3-5 20	225 91 42 6-11 5-9 20	300 122 56 9-14 8-12 20	375 152 70 12-17 10-15 22	450 183 84 14-19 12-17 27	525 213 98 16-21 14-18 32						
9" X 15" Ak = .542	TOTAL CFM CFM/SIDE THROW NC	188 80 28 4-8 3-5 20	281 120 42 7-12 5-9 20	375 159 56 10-15 8-12 20	469 199 70 12-18 10-15 23	563 239 84 15-20 12-17 28	656 279 98 17-22 14-18 33						
9" X 18" Ak = .650	TOTAL CFM CFM/SIDE THROW NC	225 98 28 5-9 3-5 20	338 148 42 8-13 5-9 20	450 197 56 11-16 8-12 20	563 246 70 13-19 10-15 24	675 295 84 15-21 12-17 29	788 345 98 17-23 14-18 34						
9" X 21" Ak = .759	TOTAL CFM CFM/SIDE THROW NC	263 117 28 5-10 3-5 20	394 176 42 8-14 5-19 20	525 234 56 11-17 8-12 20	656 293 70 14-20 10-15 25	788 352 84 16-22 13-18 30	919 410 98 18-24 14-18 35						
12" X 15" Ak = .723	TOTAL CFM CFM/SIDE THROW NC	250 100 50 5-10 3-6 20	375 150 75 8-13 6-10 20	500 200 100 11-16 9-14 20	625 250 125 13-19 11-16 25	750 300 150 15-21 13-18 30	875 350 175 17-23 15-20 35						
12" X 18" Ak = .867	TOTAL CFM CFM/SIDE THROW NC	300 125 50 5-11 3-7 20	450 188 75 8-14 6-10 20	600 250 100 11-18 9-14 20	750 313 125 14-20 11-16 25	900 375 150 16-22 15-20 30	1050 438 175 18-24 15-20 35						
12" X 21" Ak = 1.012	TOTAL CFM CFM/SIDE THROW NC	375 148 78 6-12 4-8 20	563 223 117 9-15 7-12 20	750 297 156 12-19 10-15 21	938 371 195 15-21 12-18 26	1125 445 234 17-23 15-20 31	1313 520 273 19-25 17-22 36						
12" X 24" Ak = 1.156	TOTAL CFM CFM/SIDE THROW NC	438 180 78 6-13 4-8 20	656 270 117 10-17 7-12 20	875 359 156 13-20 10-15 22	1094 449 195 16-22 12-18 27	1313 539 234 18-27 16-22 32	1531 629 273 20-26 17-22 37						
15" X 18" Ak = 1.084	TOTAL CFM CFM/SIDE THROW NC	525 206 113 7-14 5-10 20	788 309 169 10-17 8-14 20	1050 413 225 13-21 11-17 23	1313 516 281 16-23 14-20 28	1575 619 338 19-25 16-22 33	1837 722 394 21-27 18-23 38						
15" X 24" Ak = 1.445	TOTAL CFM CFM/SIDE THROW NC	600 244 113 7-15 5-10 20	900 366 169 11-19 8-14 20	1200 488 225 14-22 11-17 23	1500 609 281 17-24 14-20 28	1800 731 338 19-26 17-23 33	2100 853 394 22-28 18-23 38						
18" X 24" Ak = 1.734	TOTAL CFM CFM/SIDE THROW NC	788 317 153 8-17 6-12 20	1181 476 230 12-20 9-16 20	1575 634 306 15-24 12-19 24	1969 793 383 18-26 15-21 29	2362 952 459 21-28 34	2756 1110 536 23-30 19-25 39						

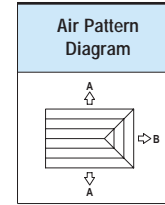

Directional Ceiling Diffusers



DCD

See Page DCD-43 for Performance Notes



# DCD - Directional Ceiling Diffusers

## Series 5000 - Performance/(SC) 2-Way Adjacent or (S2) Opposite Pattern

Models 5000 (-1, -2, -4, -46, -6, -7, -8, -9)

NECK SIZE Ak	Ps Pt	NECK VELOCITY					
		200	300	400	500	600	700
		.006 .008	.013 .018	.022 .032	.035 .050	.050 .072	.068 .099
6" X 6" Ak = .132	TOTAL CFM	50	75	100	125	150	175
	CFM/SIDE THROW NC	25 2-5 20	38 5-9 20	50 8-12 20	63 10-14 20	75 12-17 20	88 14-18 25
9" X 9" Ak = .298	TOTAL CFM	113	169	225	281	338	394
	CFM/SIDE THROW NC	56 3-7 20	84 6-11 20	113 9-14 20	141 12-17 21	169 14-19 26	197 16-20 31
12" X 12" Ak = .529	TOTAL CFM	200	300	400	500	600	700
	CFM/SIDE THROW NC	100 5-10 20	150 8-13 20	200 11-16 20	250 13-19 24	300 15-21 29	350 17-23 34
15" X 15" Ak = .827	TOTAL CFM	313	469	625	781	938	1094
	CFM/SIDE THROW NC	156 6-12 20	234 9-16 20	313 12-19 21	391 15-21 26	469 17-24 31	547 19-25 36
18" X 18" Ak = 1.190	TOTAL CFM	450	675	900	1125	1350	1575
	CFM/SIDE THROW NC	225 7-14 20	338 10-18 20	450 14-21 22	563 17-24 27	675 19-26 32	788 21-28 37
21" X 21" Ak = 1.620	TOTAL CFM	613	919	1225	1531	1837	2144
	CFM/SIDE THROW NC	306 8-17 20	459 12-20 20	613 15-23 23	766 18-26 28	919 21-28 33	1072 23-30 38
24" X 24" Ak = 2.116	TOTAL CFM	800	1200	1600	2000	2400	2800
	CFM/SIDE THROW NC	400 9-18 20	600 13-22 20	800 16-25 24	1000 19-28 29	1200 22-30 34	1400 24-30 39
27" X 27" Ak = 2.679	TOTAL CFM	1013	1519	2025	2531	3037	3544
	CFM/SIDE THROW NC	506 10-20 20	759 14-24 20	1013 17-27 25	1266 21-29 30	1519 23-32 35	1772 25-33 40

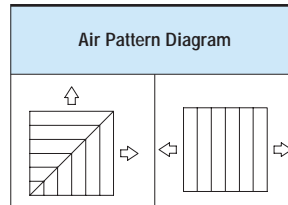

## Series 5000 - Performance/(S1) 1-Way Square Air Pattern

Models 5000 (-1, -2, -4, -46, -6, -7, -8, -9)

NECK SIZE Ak	Ps Pt	NECK VELOCITY					
		200	300	400	500	600	700
		.008 .010	.018 .023	.031 .041	.049 .064	.070 .092	.095 .126
6 x 6 Ak = .122	TOTAL CFM	50	75	100	125	150	175
	THROW NC	3-7 20	6-10 20	9-14 20	11-16 20	13-18 20	15-20 25
9 x 9 Ak = .275	TOTAL CFM	113	169	225	281	338	394
	THROW NC	5-10 20	8-14 20	11-17 20	14-20 21	16-22 26	18-23 31
12 x 12 Ak = .489	TOTAL CFM	200	300	400	500	600	700
	THROW NC	7-14 20	10-17 20	13-20 20	16-23 24	18-25 29	21-27 34
15 x 15 Ak = .764	TOTAL CFM	313	469	625	781	938	1094
	THROW NC	8-17 20	12-20 20	15-23 21	18-26 26	21-28 31	23-30 36
18 x 18 Ak = 1.100	TOTAL CFM	450	675	900	1125	1350	1575
	THROW NC	9-19 20	13-23 20	17-26 22	20-29 27	23-31 32	25-32 37
21 x 21 Ak = 1.498	TOTAL CFM	613	919	1225	1531	1837	2144
	THROW NC	10-21 20	14-25 20	18-28 23	21-31 28	24-33 33	26-35 38
24 x 24 Ak = 1.956	TOTAL CFM	800	1200	1600	2000	2400	2800
	THROW NC	11-23 20	15-27 20	19-30 24	23-32 29	25-34 34	28-36 39
27 x 27 Ak = 2.476	TOTAL CFM	1013	1519	2025	2531	3037	3544
	THROW NC	12-24 20	16-28 20	20-31 25	23-34 30	26-36 35	29-38 40

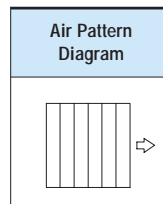

See Page DCD-43 for Performance Notes



# DCD - Directional Ceiling Diffusers

8/2006

## Series 5000 - Performance - (R2L) or (R2S) 2-Way Opposite Pattern

Models 5000 (-1, -2, -4, -46, -6, -7, -8, -9)

Directional Ceiling Diffusers



DCD

NECK SIZE Ak	Ps Pt	NECK VELOCITY					
		200	300	400	500	600	700
		.007 .009	.015 .021	.027 .037	.042 .057	.060 .082	.082 .112
6" x 9" Ak = .198	TOTAL CFM	75	113	150	188	225	263
	CFM/SIDE	38	56	75	94	113	131
	THROW	3-6	6-10	8-13	11-15	13-17	15-19
	NC	20	20	20	20	23	28
6" x 12" Ak = .265	TOTAL CFM	100	150	200	250	300	350
	CFM/SIDE	50	75	100	125	150	175
	THROW	3-7	6-10	9-14	11-16	13-18	15-20
	NC	20	20	20	20	25	30
6" x 15" Ak = .333	TOTAL CFM	125	188	250	313	375	438
	CFM/SIDE	63	94	125	156	188	219
	THROW	4-7	6-11	9-14	12-17	14-19	16-21
	NC	20	20	20	21	26	31
6" x 18" Ak = .397	TOTAL CFM	150	225	300	375	450	525
	CFM/SIDE	75	113	150	188	225	263
	THROW	4-8	7-12	10-15	12-18	14-20	16-21
	NC	20	20	20	22	27	32
9" x 15" Ak = .496	TOTAL CFM	188	281	375	469	563	656
	CFM/SIDE	94	141	188	234	281	328
	THROW	4-9	7-13	10-16	13-19	15-21	17-22
	NC	20	20	20	23	28	33
9" x 18" Ak = .595	TOTAL CFM	225	338	450	563	675	788
	CFM/SIDE	113	169	225	281	338	394
	THROW	5-10	8-14	11-17	14-20	16-22	18-23
	NC	20	20	20	24	29	34
9" x 21" Ak = .694	TOTAL CFM	263	394	525	656	788	919
	CFM/SIDE	131	197	263	328	394	459
	THROW	5-11	8-15	12-18	14-20	17-23	19-24
	NC	20	20	20	25	30	35
12" x 15" Ak = .661	TOTAL CFM	250	375	500	625	750	875
	CFM/SIDE	125	188	250	313	375	438
	THROW	5-11	8-14	11-18	14-20	16-22	18-24
	NC	20	20	20	25	30	35
12" x 18" Ak = .794	TOTAL CFM	300	450	600	750	900	1050
	CFM/SIDE	150	225	300	375	450	525
	THROW	6-12	9-15	12-19	15-21	17-23	19-25
	NC	20	20	20	25	30	35
12" x 21" Ak = .926	TOTAL CFM	350	525	700	875	1050	1225
	CFM/SIDE	175	263	350	438	525	613
	THROW	6-13	9-16	13-20	15-22	18-24	20-26
	NC	20	20	21	26	31	36
15" x 21" Ak = 1.157	TOTAL CFM	438	656	875	1094	1313	1531
	CFM/SIDE	219	328	438	547	656	766
	THROW	7-14	10-18	14-21	16-24	19-26	21-27
	NC	20	20	22	27	32	37
15" x 24" Ak = 1.323	TOTAL CFM	500	750	1000	1250	1500	1750
	CFM/SIDE	250	375	500	625	750	875
	THROW	7-15	11-19	14-22	17-25	20-27	22-28
	NC	20	20	22	27	32	37
18" x 21" Ak = 1.386	TOTAL CFM	525	788	1050	1313	1575	1837
	CFM/SIDE	263	394	525	656	788	919
	THROW	7-15	11-19	14-22	17-25	20-27	22-29
	NC	20	20	23	28	33	38
18" x 24" Ak = 1.587	TOTAL CFM	600	900	1200	1500	1800	2100
	CFM/SIDE	300	450	600	750	900	1050
	THROW	8-16	12-20	15-23	18-26	21-28	23-30
	NC	20	20	23	28	33	38
21" x 27" Ak = 2.083	TOTAL CFM	788	1181	1575	1969	2362	2756
	CFM/SIDE	394	591	788	984	1181	1378
	THROW	9-18	13-22	16-25	19-28	22-30	24-32
	NC	20	20	24	29	34	39

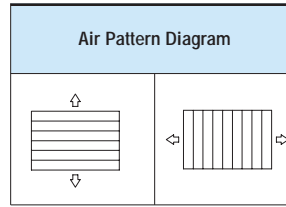

See Page DCD-43 for Performance Notes

# DCD - Directional Ceiling Diffusers

## Series 5000 - Performance- (R1L) or (R1S) 1-Way Rectagular Pattern

Models 5000 (-1, -2, -4, -46, -6, -7, -8, -9)

NECK SIZE Ak	Ps Pt	NECK VELOCITY					
		200	300	400	500	600	700
		.008 .010	.018 .023	.031 .041	.049 .064	.070 .092	.095 .126
6" x 9" Ak = .183	TOTAL CFM	75	113	150	188	225	263
	THROW	4-8	7-12	10-15	12-18	14-20	16-21
	NC	20	20	20	20	23	28
6" x 12" Ak = .244	TOTAL CFM	100	150	200	250	300	350
	THROW	5-10	8-13	11-16	13-19	15-21	17-23
	NC	20	20	20	20	25	30
6" x 15" Ak = .307	TOTAL CFM	125	188	250	313	375	438
	THROW	5-11	8-14	11-18	14-20	16-22	18-24
	NC	20	20	20	21	26	31
6" x 18" Ak = .366	TOTAL CFM	150	225	300	300	450	525
	THROW	6-12	9-15	12-19	12-19	17-23	19-25
	NC	20	20	20	20	27	32
6" x 21" Ak = .429	TOTAL CFM	175	263	350	438	525	613
	THROW	6-13	9-16	13-20	15-22	18-24	20-26
	NC	20	20	20	23	28	33
9" x 15" Ak = .458	TOTAL CFM	188	281	375	469	563	656
	THROW	6-13	10-17	13-20	16-23	18-25	20-26
	NC	20	20	20	23	28	33
9" x 18" Ak = .550	TOTAL CFM	225	338	450	563	675	788
	THROW	7-14	10-18	14-21	17-24	19-26	21-28
	NC	20	20	20	24	29	34
12" x 15" Ak = .611	TOTAL CFM	250	375	500	625	750	875
	THROW	7-15	11-19	14-22	17-25	20-27	22-28
	NC	20	20	20	25	30	35
12" x 18" Ak = .733	TOTAL CFM	300	450	600	750	900	1050
	THROW	8-16	12-20	15-23	18-26	21-28	23-30
	NC	20	20	20	25	30	35
15" x 21" Ak = 1.070	TOTAL CFM	438	656	875	1094	1313	1531
	THROW	9-19	13-23	17-26	20-28	22-31	25-32
	NC	20	20	22	27	32	37
15" x 24" Ak = 1.222	TOTAL CFM	500	750	1000	1250	1500	1750
	THROW	10-20	14-24	17-27	20-29	23-31	25-33
	NC	20	20	22	27	32	37
18" x 21" Ak = 1.278	TOTAL CFM	525	788	1050	1313	1575	1837
	THROW	10-20	14-24	18-27	21-30	23-32	26-34
	NC	20	20	23	28	33	38
18" x 24" Ak = 1.467	TOTAL CFM	600	900	1200	1500	1800	2100
	THROW	10-21	14-25	18-28	21-31	24-33	26-34
	NC	20	20	23	28	33	38
21" x 27" Ak = 1.925	TOTAL CFM	788	1181	1575	1969	2362	2756
	THROW	11-23	15-26	19-30	23-32	25-34	28-36
	NC	20	20	24	29	34	39

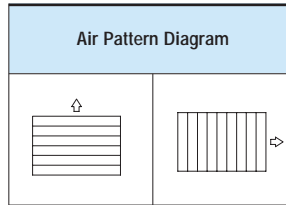

### Series 5000 - Performance Notes:

All data are tested in accordance with ANSI/ASHRAE 70-1991

### Definition of Units:

- CFM - Cubic Feet per Minute (air)
- fpm - Velocity of air stream in Feet Per Minute
- Pv - Velocity pressure (inches of water column)
- Pt - Total pressure (inches of water column)
- Ps - Static pressure = Pt - Pv (inches of water column)
- Throw - Cataloged throw is horizontal distances in feet to the terminal velocities of 150 and 50 fpm with ambient supply air temperature.
- NC - Noise criterion, sound pressure level. NC ratings are based on sound power level (Lw) RE: 10E-12 watts minus a 10 dB room attenuation in all octave bands
- Ak - Area Factor





## Series 5000 - Specifications

- 5000-1 – Surface Mount
- 5000-4 – Drop Face
- 5000-46 – Drop Face – T-Bar Lay-in
- 5000-6 – T-bar Lay-in
- 5000-7 – Concealed Spline
- 5000-8 – Tegular Lay-in
- 5000-9 – Donn Finline

Air Outlets shall be aluminum model 5000 manufactured by METALAIRE®. Units shall consist of a fixed pattern louvered core fastened into a border with spring loaded latches. Core shall be removable without the use of tools. Outlets shall be engineered for high capacity applications and include straight deflector blades (without a horizontal lip). Units with a horizontal lip at the ends of the deflector blades are not acceptable. The units shall be the size and quantity as outlined in the plans and specifications.

Outlets shall be available in 1, 2 way opposite, 2 way corner, 3, and 4 way directional air patterns.

Units shall be designed to integrate into the specified ceiling system.

### Options

#### **Adjustable Pattern (horizontal to vertical)**

Outlets shall include adjustable air pattern deflector blades that allows the air pattern to be set from vertical to horizontal (Optional APD Air Pattern Deflectors). Air pattern deflector blades shall be accessible from the face and the diffuser and adjustable without the use of tools.

#### **IV Induction Vanes**

Units shall include IV induction vanes factory mounted onto the back side of the deflector vanes. IV vanes shall increase the induction rate of the diffuser.

### Accessories

#### **Optional Dampers**

Aluminum D5A or Steel D5 opposed blade dampers shall be provided. Damper shall be adjusted using a handle accessible through the face of the diffuser.

Screwdriver slot operators are not allowed.

### Performance Specification

The manufacturer shall provide published performance data. Data shall be tested in accordance to ANSI/ASHRAE Standard 70-1991.

### Paint Specification

Process shall be anodic electrodeposition using an anodic acrylic paint. Units shall undergo pre-treatment including a pressurized spray stage using an alkaine cleaner and a de-ionized water rinse.

Film Properties shall meet or exceed the following standards:

Property	Test Method	Performance
Film thickness		.8-1.0 mils
Film Cure		320 F @ 20 min
Gloss – 60 deg.	ASTM D523-89	70-80%
Pencil Hardness	ASTM D3363-92A	HB-H
Crosshatch Adhesion	ASTM D3359-95	4B-5B
Direct Impact	ASTM D2794-93	60 in.lbs. Min
Reverse Impact	ASTM D2794-93	60 in.lbs. Min.
Salt Spray	ASTM B117-95	48-96 Hours
Humidity	ASTM D1735-92	500 Hours
Water Soak	ASTM D870-92	250 Hours



# DCD - Directional Ceiling Diffusers

## Series 5000 - Model Specification Guide

Square/Rectangular Louver Face Ceiling Diffusers  
Series 5000 - Extruded Aluminum

Model	Available Neck	Air Pattern	Available Finishes	Available Options	
5000-1 - Surface Mount 5000-2 - V-Beveled Drop Surface Mount 5000-4 - Drop Face Surface Mount	6" thru 48"	Standard	Standard	D5	Opposed Blade Damper - Steel
		S4 - Sq. 4-way	01 - White	D5A	Opposed Blade Damper - Aluminum
		Optional	Optional	L9	Equalizing Grid
		S1 - Sq. 1-way	02 - Aluminum	TR	Square to Round Transition
		S2 - Sq. 2-way	03 - Black	TR DEEP	Square to Round Transition - Deep
		S3 - Sq. 3-way	24 - Mill	G3	Equalizing Grid
		SC - Sq. 2-way corner	28 - Custom Color	BDS	Butterfly Damper
		R1S - Rct. 1-way short		RSD	Radial Shutter Damper
		R1L - Rct. 1-way long		IV	Induction Vanes
		R2S - Rct. 2-way short		APD	Air Pattern Deflectors
		R2L - Rct. 2-way long			
		R3S - Rct. 3-way short			
		R3L - Rct. 3-way long			
		R4 - Rct. 4-way			

Square/Rectangular Louver Face Ceiling Diffusers  
Series 5000 - Extruded Aluminum  
For T-bar Lay-in Ceiling Grid Applications

Model	Available Neck	Module	Air Pattern	Available Finishes	Available Options	
5000-46 - Drop Face - T-bar Lay-in 5000-6 - T-bar Lay-in 5000-7 - Concealed Spline 5000-8 - Tegular T-bar 5000-9 - Donn Finline	6" thru 42"	12" x 12" 24" x 24" 36" x 24" 48" x 24" 48" x 48"	Standard	Standard	D5	Opposed Blade Damper - Steel
			S4 - Sq. 4-way	01 - White	D5A	Opposed Blade Damper - Aluminum
			Optional	Optional	L9	Equalizing Grid
			S1 - Sq. 1-way	02 - Aluminum	TR	Square to Round Transition
			S2 - Sq. 2-way	03 - Black	TR DEEP	Square to Round Transition - Deep
			S3 - Sq. 3-way	24 - Mill	G3	Equalizing Grid
			SC - Sq. 2-way corner	28 - Custom Color	BDS	Butterfly Damper
			R1S - Rct. 1-way short		RSD	Radial Shutter Damper
			R1L - Rct. 1-way long		IV	Induction Vanes
			R2S - Rct. 2-way short		APD	Air Pattern Deflectors
			R2L - Rct. 2-way long			
			R3S - Rct. 3-way short			
			R3L - Rct. 3-way long			
			R4 - Rct. 4-way			



## ➔ Square/Rectangular Louver Face ➔ Series 5500 ➔ Aluminum

Directional Ceiling Diffusers



DCD

### Product Details

- ★ Available in 1, 2-way opposite, 2-way corner, 3, and 4-way directional air patterns
- ★ Cores are easy to remove with spring loaded latches - no tools required
- ★ 5500 series deflector blades include a horizontal lip, making this diffuser an excellent choice for high induction applications
- ★ The 5500 series is an excellent choice for VAV applications
- ★ The 5500 series is available with optional induction vanes

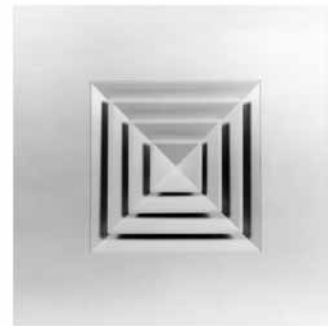

**Model 5500-2 S4 Shown**  
Standard Finish: 01 White

Dimensions are in inches

### Square/Rectangular Louver Face Ceiling Diffusers Surface Mount Model 5500-1

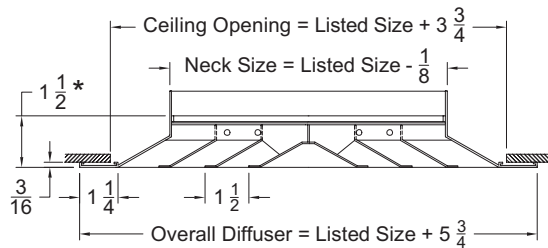

### Square/Rectangular Louver Face Ceiling Diffusers V-Beveled Drop Surface Mounting Model 5500-2

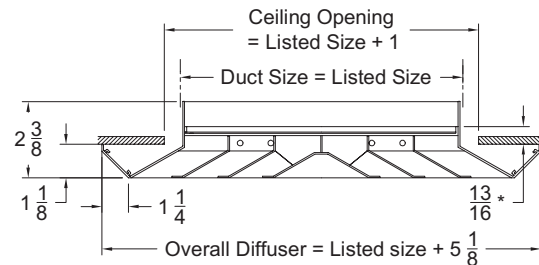

### Square/Rectangular Louver Face Ceiling Diffusers Drop Face Surface Mount Model 5500-4

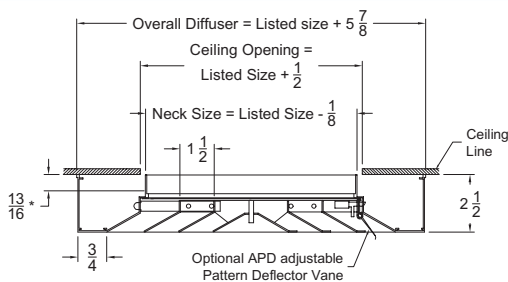

### Square/Rectangular Louver Face Ceiling Diffusers Drop Face T-bar Lay-in Model 5500-46

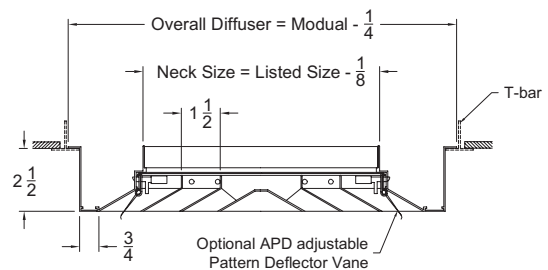

### Square/Rectangular Louver Face Ceiling Diffusers T-bar Lay-in Model 5500-6

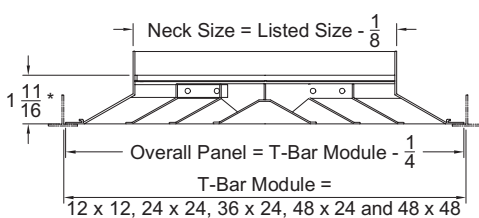

### Square/Rectangular Louver Face Ceiling Diffusers Concealed Spine Model 5500-7

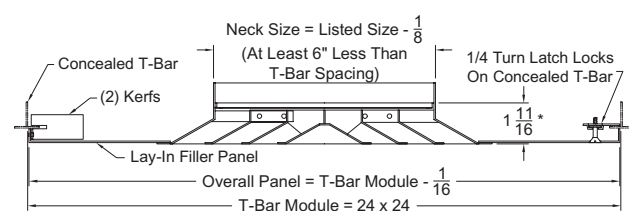

# DCD - Directional Ceiling Diffusers

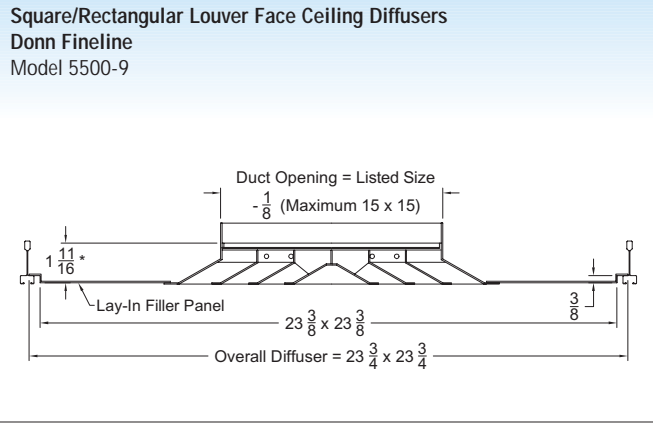
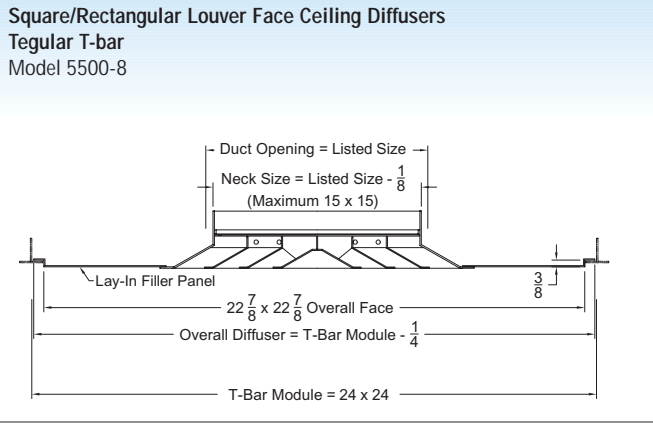

**Air Patterns - (Square) Louver Face Ceiling Diffusers**

S1 - One Way	S2 - Two Way Opposite	SC - Two Way Corner	S3 - Three Way	S4 - Four Way

**Air Patterns - (Rectangular)**

Short Louver Face Ceiling Diffusers				Long Louver Face Ceiling Diffusers		
R1 - One Way	R2S - Two Way Opposite	R3S - Three Way	R4 - Four Way	R1L - One Way	R2L - Two Way	R3L - Three Way

**Options and Accessories**

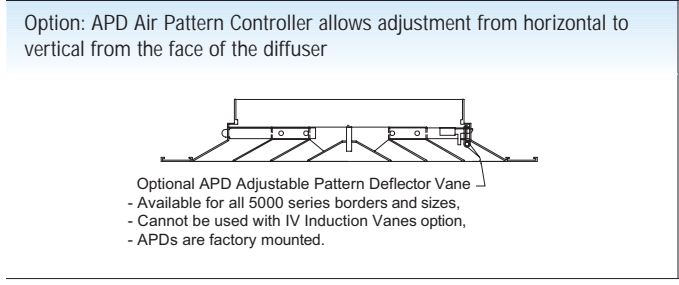
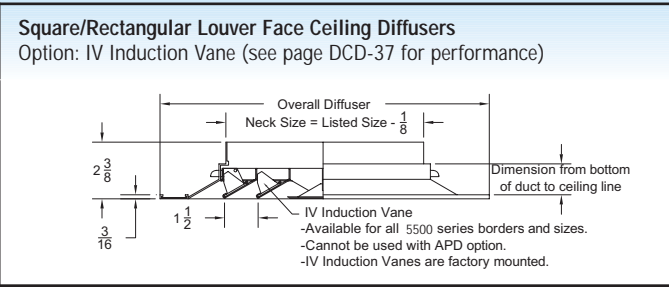
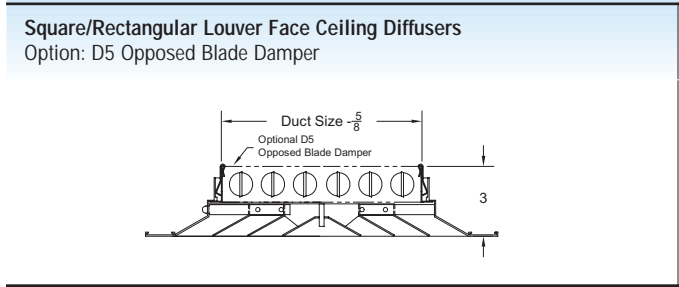

1. Available Finishes	2. Available Accessories	3. Available Options	4. Construction Details
<p><b>Standard Finish:</b></p> <ul style="list-style-type: none"> <li>01 White</li> </ul> <p><b>Optional Finish</b></p> <ul style="list-style-type: none"> <li>02 Aluminum paint</li> <li>03 Black</li> <li>24 Mill finish</li> <li>28 Custom color</li> </ul> <p><b>Note:</b></p> <p>Anodized Finish not available</p>	<p>(Shipped Unattached)</p> <p><b>Square and Rectangular Neck:</b></p> <ul style="list-style-type: none"> <li>D5 - Opposed Blade Damper - Steel . . . . .337</li> <li>D5A - Opposed Blade Damper - Aluminum . . .337</li> <li>L9 - Equalizing Grid . . . . .334</li> <li>TR - Square to Round Transition . . . . .338</li> </ul> <p><b>Round Neck:</b></p> <ul style="list-style-type: none"> <li>G3 - Equalizing Grid . . . . .337</li> <li>BDS - Butterfly Damper . . . . .335</li> <li>RSD - Radial Shutter Damper . . . . .336</li> </ul>	<p><b>Factory Mounted:</b></p> <ul style="list-style-type: none"> <li>IV - Induction Vanes</li> </ul> <p><b>APD - Air Pattern Deflectors</b> allows adjustment from horizontal to vertical air pattern from the face of the diffuser</p> <p><b>Note:</b></p> <p>IV (Induction Vanes) can not be used with APD (Air Pattern Deflector) option and vice-versa</p>	<ul style="list-style-type: none"> <li>• Available air patterns: S1, S2, S3, S4, R1S, R1L, R2S, R2L, R3S, R3L, R4 and SC (Type)</li> <li>• For 5500-6 models only: 21" x 21" neck in 24" x 24" module is available in S4 pattern only</li> </ul>

See Page DCD-52 for Performance Notes

For more product information visit us at [www.metalair.com](http://www.metalair.com)

# DCD - Directional Ceiling Diffusers

8/2006

## ➔ Square/Rectangular Louver Face ➔ Series 5500S ➔ Steel

Directional Ceiling Diffusers



DCD

### Product Details

- ✦ Available in 1, 2-way opposite, 2-way corner, 3, and 4-way directional air patterns
- ✦ Cores are easy to remove with spring loaded latches - no tools required
- ✦ 5500S series deflector blades include a horizontal lip, making this diffuser an excellent choice for high induction applications
- ✦ The 5500S series is an excellent choice for VAV applications
- ✦ The 5500S is also available with optional induction vanes

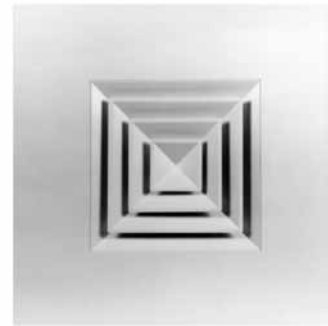

**Model 5500S-6 S4 Shown**

Standard Finish: 01 White

Dimensions are in inches

**Square/Rectangular Louver Face Ceiling Diffusers**  
Surface Mount - Steel  
Model 5500S-1

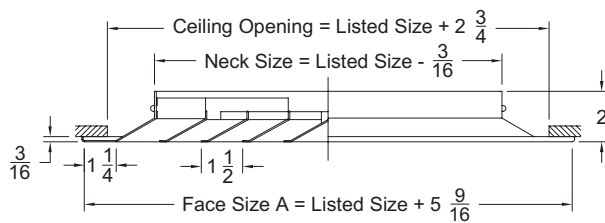

**Square/Rectangular Louver Face Ceiling Diffusers**  
V-Beveled Drop Surface Mounting - Steel  
Model 5500S-2

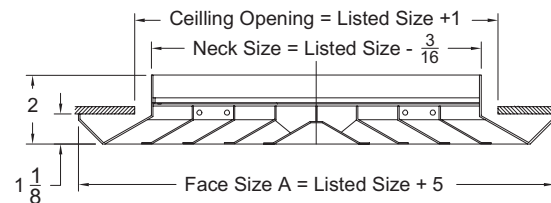

**Square/Rectangular Louver Face Ceiling Diffusers**  
T-bar Lay-in - Steel  
Model 5500S-6

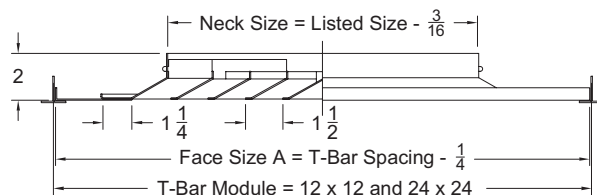

**Square/Rectangular Louver Face Ceiling Diffusers**  
Tegular T-bar - Steel  
Model 5500S-8

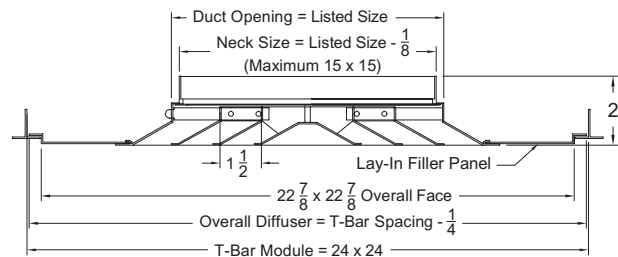

**Square/Rectangular Louver Face Ceiling Diffusers**  
Donn Fineline - Steel  
Model 5500S-9

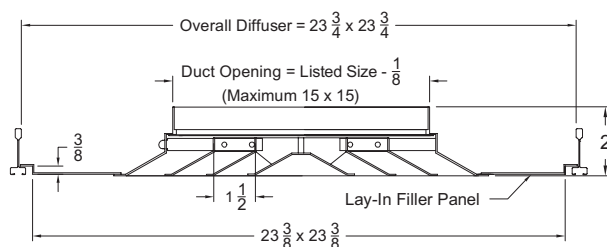

# DCD - Directional Ceiling Diffusers



Air Patterns - (Square) Louver Face Ceiling Diffusers				
S1 - One Way	S2 - Two Way Opposite	SC - Two Way Corner	S3 - Three Way	S4 - Four Way

Air Patterns - (Rectangular)						
Short Louver Face Ceiling Diffusers				Long Louver Face Ceiling Diffusers		
R1 - One Way	R2S - Two Way Opposite	R3S - Three Way	R4 - Four Way	R1L - One Way	R2L - Two Way	R3L - Three Way

Options and Accessories	
<p><b>Square/Rectangular Louver Face Ceiling Diffusers</b> Option: D5 Opposed Blade Damper</p>	<p><b>Square/Rectangular Louver Face Ceiling Diffusers</b> Option: IV Induction Vane (see page DCD-37 for performance)</p> <p>IV Induction Vane - Available for all 5500S series borders and sizes. - Cannot be used with APD option. - IV Induction Vanes are factory mounted.</p>
<p>Option: APD Air Pattern Controller allows adjustment from horizontal to vertical from the face of the diffuser</p> <p>Optional APD Adjustable Pattern Deflector Vane - Available for all 5000 series borders and sizes, - Cannot be used with IV Induction Vanes option, - APDs are factory mounted.</p>	

1. Available Finishes	2. Available Accessories	3. Available Options	4. Construction Details
<p><b>Standard Finish:</b> 01 White</p> <p><b>Optional Finish</b> 02 Aluminum 03 Black 28 Custom Color</p>	<p>(Shipped Unattached)</p> <p><b>Square and Rectangular Neck:</b> D5 - Opposed Blade Damper - Steel . . . . .337 D5A - Opposed Blade Damper - Aluminum . . .337 L9 - Equalizing Grid . . . . .334 TR - Square to Round Transition . . . . .338</p> <p><b>Round Neck:</b> G3 - Equalizing Grid . . . . .337 BDS - Butterfly Damper . . . . .335 RSD - Radial Shutter Damper . . . . .336</p>	<p><b>Factory Mounted:</b> IV - Induction Vanes APD - Air Pattern Deflectors allows adjustment from horizontal to vertical air pattern from the face of the diffuser</p> <p><b>Note:</b> IV (Induction Vanes) can not be used with APD (Air Pattern Deflector) option and vice-versa</p>	<ul style="list-style-type: none"> <li>Available air patterns: S1, S2, S3, S4, R1S, R1L, R2S, R2L, R3S, R3L, R4 and SC</li> <li>For 5500S-6 models only: 21x21 neck in 24x24 module is available in S4 pattern only</li> </ul>

See Page DCD-52 for Performance Notes

# DCD - Directional Ceiling Diffusers

## Series 5500/5500S - Performance

Models 5500 (frame styles: -1, -2, -4, -46, -6, -7, -8, -9)  
 Models 5500S (frame styles: -1, -2, -4, -46, -6, -7, -8, -9)  
 (S1) 1-Way Square Air Pattern

Directional Ceiling Diffusers



DCD

NECK SIZE Ak	Ps Pt	NECK VELOCITY					
		200	300	400	500	600	700
		.018 .020	.040 .046	.071 .081	.111 .127	.160 .182	.218 .248
6 x 6 Ak = .087	TOTAL CFM THROW NC	50 5-9 -	75 8-15 -	100 13-20 -	125 18-26 -	150 22-31 23	175 26-37 28
9 x 9 Ak = .197	TOTAL CFM THROW NC	113 8-16 -	169 12-21 -	225 17-27 -	281 22-32 24	338 27-38 29	394 31-44 34
12 x 12 Ak = .350	TOTAL CFM THROW NC	200 11-22 -	300 16-27 -	400 21-33 22	500 26-38 27	600 31-44 32	700 35-50 37
15 x 15 Ak = .546	TOTAL CFM THROW NC	313 12-24 -	469 17-30 -	625 23-35 24	781 28-41 29	938 33-47 34	1094 37-52 39
18 x 18 Ak = .787	TOTAL CFM THROW NC	450 14-26 -	675 22-32 20	900 33-45 25	1125 36-48 30	1350 38-52 35	1575 40-56 40
21 x 21 Ak = 1.071	TOTAL CFM THROW NC	613 16-28 -	919 26-34 21	1225 33-43 26	1531 37-51 31	1837 40-55 36	2144 42-58 41
24 x 24 Ak = 1.399	TOTAL CFM THROW NC	800 19-29 -	1200 28-36 22	1600 39-45 27	2000 40-53 32	2400 41-59 37	2800 44-61 42
27 x 27 Ak = 1.770	TOTAL CFM THROW NC	1013 21-31 -	1519 30-39 23	2025 35-49 28	2531 41-55 33	3037 43-60 38	3544 46-64 43

Models 5500 (-1, -2, -4, -46, -6, -7, -8, -9)  
 Models 5500S (-1, -2, -4, -46, -6, -7, -8, -9)  
 (SC) 2-Way Adjacent or or (S2) Opposite Pattern

NECK SIZE Ak	Ps Pt	NECK VELOCITY					
		200	300	400	500	600	700
		.018 .020	.040 .046	.071 .081	.111 .127	.160 .182	.218 .248
6 x 6 Ak = .087	TOTAL CFM CFM/SIDE THROW NC	50 25 3-6 -	75 38 7-12 -	100 50 11-17 -	125 63 16-23 -	150 75 20-28 23	175 88 24-34 28
9 x 9 Ak = .197	TOTAL CFM CFM/SIDE THROW NC	113 56 5-10 -	169 84 9-15 -	225 113 13-21 -	281 141 18-27 24	338 169 23-32 29	394 197 27-38 34
12 x 12 Ak = .350	TOTAL CFM CFM/SIDE THROW NC	200 100 7-14 -	300 150 12-20 -	400 200 16-26 22	500 250 21-31 27	600 300 26-37 32	700 350 30-42 37
15 x 15 Ak = .546	TOTAL CFM CFM/SIDE THROW NC	313 156 10-19 -	469 234 14-25 -	625 313 19-30 24	781 391 25-36 29	938 469 30-41 34	1094 547 33-47 39
18 x 18 Ak = .787	TOTAL CFM CFM/SIDE THROW NC	450 225 12-23 -	675 338 16-28 20	900 450 22-34 25	1125 563 27-39 30	1350 675 32-45 35	1575 788 36-51 40
21 x 21 Ak = 1.071	TOTAL CFM CFM/SIDE THROW NC	613 306 12-24 -	919 459 17-30 21	1225 613 23-35 26	1531 766 28-41 31	1837 919 33-47 36	2144 1072 37-52 41
24 x 24 Ak = 1.399	TOTAL CFM CFM/SIDE THROW NC	800 400 12-22 -	1200 600 16-28 22	1600 800 21-34 27	2000 1000 27-39 32	2400 1200 32-45 37	2800 1400 36-50 42
27 x 27 Ak = 1.770	TOTAL CFM CFM/SIDE THROW NC	1013 506 8-15 -	1519 759 12-21 23	2025 1013 17-27 28	2531 1266 22-32 33	3037 1519 27-38 38	3544 1772 31-43 43

See Page DCD-52 for Performance Notes

# DCD - Directional Ceiling Diffusers

## Series 5500/5500S - Performance

Models 5500 (-1, -2, -4, -46, -6, -7, -8, -9)

Models 5500S (-1, -2, -4, -46, -6, -7, -8, -9)

(S3) 3 Way Square Pattern

NECK SIZE Ak	Ps Pt Side Designation	NECK VELOCITY											
		200		300		400		500		600		700	
		.013 .016		.030 .036		.053 .063		.083 .099		.120 .142		.163 .194	
		A	B	A	B	A	B	A	B	A	B	A	B
6 x 6 Ak = .100	TOTAL CFM CFM/SIDE THROW NC	50		75		100		125		150		175	
		19 13 3-5 0	28 19 6-11 0	38 25 10-16 0	47 31 15-22 0	56 38 20-28 23	66 44 24-33 28						
9 x 9 Ak = .225	TOTAL CFM CFM/SIDE THROW NC	113		169		225		281		338		394	
		42 28 4-8 0	63 42 8-14 0	84 56 12-19 0	105 70 17-25 24	127 84 22-31 29	148 98 26-36 34						
12 x 12 Ak = .400	TOTAL CFM CFM/SIDE THROW NC	200		300		400		500		600		700	
		75 50 6-12 0	113 75 10-17 0	150 100 15-23 22	188 125 20-29 27	225 150 24-34 32	263 175 28-40 37						
15 x 15 Ak = .625	TOTAL CFM CFM/SIDE THROW NC	313		469		625		781		938		1094	
		75 50 6-12 0	176 117 12-22 0	234 156 17-27 24	293 195 23-33 29	352 234 27-38 34	410 273 31-44 39						
18 x 18 Ak = .900	TOTAL CFM CFM/SIDE THROW NC	450		675		900		1125		1350		1575	
		169 113 10-20 0	253 169 15-25 20	338 225 20-31 25	422 281 25-37 30	506 338 30-42 35	591 394 34-48 40						
21 x 21 Ak = 1.225	TOTAL CFM CFM/SIDE THROW NC	613		919		1225		1531		1837		2144	
		230 153 12-23 0	345 230 16-28 21	459 306 22-34 26	574 383 27-40 31	689 459 32-45 36	804 536 36-51 41						
24 x 24 Ak = 1.600	TOTAL CFM CFM/SIDE THROW NC	800		1200		1600		2000		2400		2800	
		300 200 12-24 0	450 300 17-30 22	600 400 23-35 27	750 500 28-41 32	900 600 33-47 37	1050 700 37-52 42						
27 x 27* Ak = 2.025	TOTAL CFM CFM/SIDE THROW NC	1013		1519		2025		2531		3037		3544	
		380 253 12-23 0	570 380 17-29 23	759 506 22-34 28	949 633 27-40 33	1139 759 32-46 38	1329 886 36-51 43						

See Page DCD-52 for Performance Notes

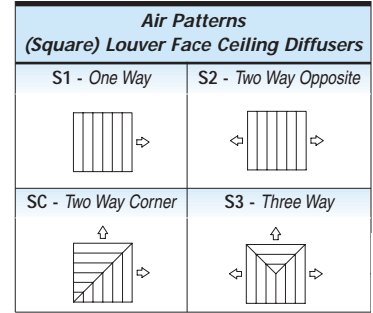

Directional Ceiling Diffusers



DCD

# DCD - Directional Ceiling Diffusers

8/2006

## Series 5500/5500S - Performance

Models 5500 (-1, -2, -4, -46, -6, -7, -8, -9 frame styles)  
 Models 5500S (-1, -2, -4, -46, -6, -7, -8, -9 frame styles)  
 (S4) 4-Way Square Pattern

NECK SIZE Ak	Ps Pt	NECK VELOCITY					
		200	300	400	500	600	700
		.013 .016	.030 .036	.053 .063	.083 .099	.120 .142	.163 .194
6 x 6 Ak = .100	TOTAL CFM	50	75	100	125	150	175
	CFM/SIDE	13	19	25	31	38	44
	THROW NC	2-4	6-10	10-16	15-21	19-27	23-32
9 x 9 Ak = .225	TOTAL CFM	113	169	225	281	338	394
	CFM/SIDE	28	42	56	70	84	98
	THROW NC	3-6	7-12	11-18	16-23	21-29	24-34
12 x 12 Ak = .400	TOTAL CFM	200	300	400	500	600	700
	CFM/SIDE	50	75	100	125	150	175
	THROW NC	5-9	8-15	13-20	18-26	22-31	26-37
15 x 15 Ak = .625	TOTAL CFM	313	469	625	781	938	1094
	CFM/SIDE	78	117	156	195	234	273
	THROW NC	6-12	10-18	15-23	20-29	25-35	29-40
18 x 18 Ak = .900	TOTAL CFM	450	675	900	1225	1350	1575
	CFM/SIDE	113	169	225	306	338	394
	THROW NC	8-16	12-21	17-27	22-32	27-38	31-44
21 x 21 Ak = 1.225	TOTAL CFM	613	919	1225	1531	1837	2144
	CFM/SIDE	153	230	306	383	459	536
	THROW NC	10-19	14-24	19-30	24-36	29-41	33-47
24 x 24 Ak = 1.600	TOTAL CFM	800	1200	1600	2000	2400	2800
	CFM/SIDE	200	300	400	500	600	700
	THROW NC	11-22	16-27	21-33	26-38	31-44	35-50
27 x 27* Ak = 2.025	TOTAL CFM	1013	1519	2025	2531	3037	3544
	CFM/SIDE	253	380	506	633	759	886
	THROW NC	12-24	17-29	22-35	28-40	33-46	37-52
33 x 33* Ak = 3.025	TOTAL CFM	1513	2269	3025	3781	4537	5294
	CFM/SIDE	378	567	756	945	1134	1323
	THROW NC	12-23	17-29	22-34	27-40	33-46	36-51

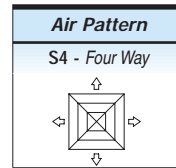

Directional Ceiling Diffusers



DCD

### Series 5500/5500S - Performance Notes:

All data are tested in accordance with ANSI/ASHRAE 70-1991

### Definition of Units:

- CFM - Cubic feet per minute (air)
- fpm - Velocity of air stream in feet per minute
- Pv - Velocity pressure (inches of water column)
- Pt - Total pressure (inches of water column)
- Ps - Static pressure = Pt - Pv (inches of water column)
- Throw - Cataloged throw is horizontal distances in feet to the terminal velocities of 150 - 50 fpm with ambient supply air temperature.
- NC - Noise criterion, sound pressure level. NC ratings are based on sound power level (Lw) RE: 10E-12 watts minus a 10 dB room attenuation in all octave bands
- Ak - Area Factor



# DCD - Directional Ceiling Diffusers

## Optional IV

### Optional IV Induction Vane

Model 5000 - Aluminum  
 Model 5500 - Aluminum  
 Model 5500S - Steel

**IV Vanes increase the induction rate of the diffuser providing higher mixing and comfort in the occupied zone**

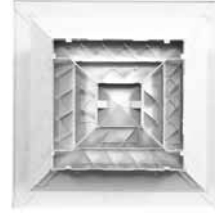
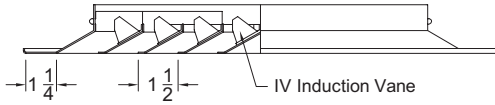

IV Induction Vane Shown (back side of diffuser)

Directional Ceiling Diffusers

## Optional IV - Performance



DCD

Performance Data		5000-IV Performance - Neck Velocity, fpm							5500-IV Performance - Neck Velocity, fpm																			
		200		300		400		500		600		700		200		300		400		500		600		700		800		
		A	B	A	B	A	B	A	B	A	B	A	B	A	B	A	B	A	B	A	B	A	B	A	B	A	B	
Size	Pv in Inches H2O	.003	.006	.010	.016	.022	.030	0.002	0.006	0.010	0.016	0.022	0.031	0.040	Pv in Inches H2O	.015	.030	.050	.078	.110	.150	0.008	0.017	0.031	0.049	0.070	0.095	0.124
	Total CFM	50	75	100	125	150	175	50	75	100	125	150	175	200														
6" x 6"	1-Way	2	4	7	8	10	11	2	6	4	8	5	9	6	10	6	11	7	12	7	13	8	15	8	15			
	2-Way	1	3	4	6	7	8	3	7	5	9	6	10	7	12	7	13	8	14	8	14	8	15	8	15			
	3-Way	1	2	2	3	3	4	4	8	5	9	6	11	7	13	8	14	9	15	10	17	10	17	10	18			
	4-Way	1	2	2	3	4	6	7	13	9	15	10	18	12	20	13	22	14	24	14	24	15	25	15	25			
	NC	<	<	<	<	<	23	<10	<15	16	18	25	28	33	28	31	35	38	42	45	48	52	55	58	62	65		
	NC	<	<	<	<	<	23	<10	<15	17	20	26	31	36	41	46	51	56	61	66	71	76	81	86	91	96		
9" x 9"	Total CFM	110	170	225	280	335	390	115	170	225	280	340	395	450														
	1-Way	4	7	10	11	12	16	3	10	5	12	7	13	9	16	10	18	11	19	12	20	13	22	13	22			
	2-Way	2	5	7	8	11	12	4	11	7	13	9	15	10	17	11	19	12	20	12	20	12	22	13	22			
	3-Way	1	2	3	5	6	7	9	11	7	14	9	16	11	19	12	21	13	23	14	25	14	25	15	27			
	4-Way	2	3	5	6	7	9	11	19	13	23	15	27	17	30	19	33	20	35	20	35	22	38	22	38			
	NC	<	<	<	<	<	23	<10	<15	17	20	26	31	36	41	46	51	56	61	66	71	76	81	86	91	96		
12" x 12"	Total CFM	200	300	400	500	600	700	200	300	400	500	600	700	800														
	1-Way	6	10	12	15	17	20	3	10	6	12	8	14	9	16	10	17	11	19	12	20	12	20	12	20			
	2-Way	4	7	9	12	13	15	5	12	8	14	9	16	11	18	12	20	12	20	12	20	12	22	13	23			
	3-Way	2	3	5	6	7	8	10	11	14	8	14	10	17	12	20	13	22	14	24	15	26	16	28	16	28		
	4-Way	2	5	7	8	9	11	12	20	14	24	16	28	18	32	20	35	22	37	22	37	23	40	23	40			
	NC	<	<	<	<	<	23	<10	<15	18	22	27	32	37	42	47	52	57	62	67	72	77	82	87	92	97		
15" x 15"	Total CFM	310	470	625	780	935	1090	315	470	625	780	940	1095	1250														
	1-Way	8	11	14	17	20	25	4	13	6	15	8	18	10	20	13	22	14	23	15	25	14	25	14	25			
	2-Way	5	8	11	12	15	17	6	14	8	18	11	20	13	23	14	25	16	27	17	29	17	29	17	29			
	3-Way	3	4	7	8	10	12	14	16	8	18	13	22	14	25	16	28	18	31	19	33	20	35	20	35			
	4-Way	3	6	8	10	12	14	14	25	18	31	20	35	23	39	25	43	25	43	27	47	29	50	29	50			
	NC	<	<	<	<	<	23	<10	<15	17	23	29	34	39	45	50	56	61	66	71	76	81	86	91	96	101		
18" x 18"	Total CFM	450	675	900	1125	1350	1575	450	675	900	1125	1350	1575	1800														
	1-Way	9	12	16	20	22	27	4	14	7	17	9	19	12	21	14	23	15	25	16	27	17	29	17	29			
	2-Way	7	10	12	15	17	22	6	16	9	19	12	22	14	25	16	27	17	29	18	31	18	31	18	31			
	3-Way	4	5	8	9	10	11	14	15	16	18	9	19	14	23	16	27	17	30	19	33	21	36	22	38			
	4-Way	4	8	10	11	14	16	16	27	19	33	22	38	25	43	27	47	29	51	29	51	31	54	31	54			
	NC	<	<	<	<	<	23	<15	19	25	30	35	40	46	51	56	61	66	71	76	81	86	91	96	101	106		
21" x 21"	Total CFM	610	920	1225	1530	1835	2140	615	920	1225	1530	1840	2145	2450														
	1-Way	10	14	18	22	25	30	4	14	7	18	9	21	12	23	14	25	16	28	17	29	18	32	20	34			
	2-Way	7	11	14	17	20	26	6	17	9	21	12	24	15	27	17	29	18	32	19	33	21	36	22	38			
	3-Way	5	6	9	10	11	12	13	15	17	19	21	23	25	27	29	31	33	35	37	39	41	43	45	47	49		
	4-Way	5	9	11	13	15	18	18	29	21	36	24	42	27	46	29	51	32	55	34	59	34	59	34	59			
	NC	<	<	<	<	<	28	<15	20	25	31	36	41	47	52	57	62	67	72	77	82	87	92	97	102	107		

### Optional IV - Performance Notes:

All data are tested in accordance with ANSI/ASHRAE 70-1991

### Definition of Units:

- CFM - Cubic feet per minute (air)
- fpm - Velocity of air stream in feet per minute
- Pv - Velocity pressure (inches of water column)
- Pt - Total pressure (inches of water column)
- Ps - Static pressure = Pt - Pv (inches of water column)
- Throw - Cataloged throw is horizontal distances in feet to the terminal velocities of 150 - 50 fpm with ambient supply air temperature.
- NC - Noise criterion, sound pressure level. NC ratings are based on sound power level (Lw) RE: 10E-12 watts minus a 10 dB room attenuation in all octave bands
- Ak - Area Factor



## Series 5500 Aluminum - Specifications

- 5500-1 – Surface Mount
- 5500-4 – Drop Face
- 5500-46 – Drop Face – T-bar Lay-in
- 5500-6 – T-bar Lay-in
- 5500-7 – Concealed Spline
- 5500-8 – Tegalur Lay-in
- 5500-9 – Donn Finline Lay-in

Air Outlets shall be aluminum model 5500 manufactured by METALAIRE®. Units shall consist of a fixed pattern louvered core fastened into a border with spring loaded latches. Core shall be removable without the use of tools. Outlets shall be engineered to perform in variable volume systems and include deflector blades with a horizontal lip to provide longer throw distances. The units shall be the size and quantity as outline in the plans and specifications.

Outlets shall be available in 1, 2-way opposite, 2-way corner, 3, and 4-way directional air patterns.

Units shall be designed to integrate into the specified ceiling system.

## Series 5500S Steel - Specifications

- 5500S-1 – Surface Mount
- 5500S-6 – T-bar Lay-in
- 5500S-8 – Tegalur Lay-in
- 5500S-9 – Donn Finline Lay-in

Air Outlets shall be steel model 5500S manufactured by METALAIRE. Units shall consist of a fixed pattern louvered core fastened into a border with spring loaded latches. Core shall be removable without the use of tools. Outlets shall be engineered to perform in variable volume systems and include deflector blades with a horizontal lip to provide longer throw distances. The units shall be the size and quantity as outline in the plans and specifications.

Outlets shall be available in 1, 2-way opposite, 2-way corner, 3, and 4-way directional air patterns.

Units shall be designed to integrate into the specified ceiling system.

### Options

#### **Adjustable Pattern (horizontal to vertical)**

Outlets shall include adjustable air pattern deflector blades that allows the air pattern to be set from vertical to horizontal (Optional APD Air Pattern Deflectors). Air pattern deflector blades shall be accessible from the face and the diffuser and adjustable without the use of tools.

#### **IV Induction Vanes**

Units shall include IV induction vanes factory mounted onto the back side of the deflector vanes. IV vanes shall increase the induction rate of the diffuser.

### Accessories

#### **Optional Dampers**

Aluminum D5A or Steel D5 opposed blade dampers shall be provided. Damper shall be adjusted using a handle accessible through the face of the diffuser. Screwdriver slot operators are not allowed.

### Performance Specification

The manufacturer shall provide published performance data. Data shall be tested in accordance to ANSI/ASHRAE Standard 70-1991.

### Paint Specification

Process shall be anodic electrodeposition using an anodic acrylic paint. Units shall undergo pre-treatment including a pressurized spray stage using an alkaine cleaner and a de-ionized water rinse.

Film Properties shall meet or exceed the following standards:

Property	Test Method	Performance
Film thickness		.8-1.0 mils
Film Cure		320 F @ 20 min
Gloss – 60 deg.	ASTM D523-89	70-80%
Pencil Hardness	ASTM D3363-92A	HB-H
Crosshatch Adhesion	ASTM D3359-95	4B-5B
Direct Impact	ASTM D2794-93	100 in.lbs. Min
Reverse Impact	ASTM D2794-93	60 in.lbs. Min.
Salt Spray	ASTM B117-95	48-96 Hours
Humidity	ASTM D1735-92	500 Hours
Water Soak	ASTM D870-92	250 Hours

# DCD - Directional Ceiling Diffusers

## Series 5500 Aluminum - Model Specification Guide

### Square/Rectangular Louver Face Ceiling Diffusers Series 5500 - Aluminum

Model	Available Neck	Air Pattern	Available Finishes	Available Options		
5500-1 - Flush Surface Mount	6" thru 48"	<b>Standard</b>	<b>Standard</b>	D5	Opposed Blade Damper - Steel	
5500-2 - V-Beveled Drop Surface Mount		S4 - Sq. 4-way	01 - White	D5A	Opposed Blade Damper - Aluminum	
5500-4 - Drop Face Surface Mount		<b>Optional</b>	<b>Optional</b>	L9	Equalizing Grid	
		S1 - Sq. 1-way	02 - Aluminum	TR	Square to Round Transition	
		S2 - Sq. 2-way	03 - Black	TR Deep	Square to Round Transition - Deep	
		S3 - Sq. 3-way	24 - Mill	G3	Equalizing Grid	
		SC - Sq. 2-way corner	28 - Custom Color	BDS	Butterfly Damper	
		R1S - Rct. 1-way short		RSD	Radial Shutter Damper	
		R1L - Rct. 1-way long		IV	Induction Vanes	
		R2S - Rct. 2-way short		APD	Air Pattern Deflectors	
		R2L - Rct. 2-way long		TR	Transition-Mounted	
		R3S - Rct. 3-way short				
		R3L - Rct. 3-way long				
		R4 - Rct. 4-way				

### Square/Rectangular Louver Face Ceiling Diffusers Series 5500 - Extruded Aluminum

Model	Available Neck	Module	Air Pattern	Available Finishes	Available Options		
5500-46 - Drop Face T-bar Lay-in	6" thru 46"	12" x 12" 24" x 24" 36" x 24" 48" x 24" 48" x 48"	<b>Standard</b>	<b>Standard</b>	D5	Opposed Blade Damper - Steel	
5500-6 - T-bar Lay-in			S4 - Sq. 4-way	01 - White	D5A	Opposed Blade Damper - Aluminum	
5500-7 - Concealed Spline			<b>Optional</b>	<b>Optional</b>	L9	Equalizing Grid	
5500-8 - Tegal T-bar			S1 - Sq. 1-way	02 - Aluminum	TR	Square to Round Transition	
5500-9 - Donn Finline			S2 - Sq. 2-way	03 - Black	TR Deep	Square to Round Transition - Deep	
			S3 - Sq. 3-way	24 - Mill	G3	Equalizing Grid	
			SC - Sq. 2-way corner	28 - Custom Color	BDS	Butterfly Damper	
			R1S - Rct. 1-way short		RSD	Radial Shutter Damper	
			R1L - Rct. 1-way long		IV	Induction Vanes	
			R2S - Rct. 2-way short		APD	Air Pattern Deflectors	
			R2L - Rct. 2-way long		TR	Transition-Mounted	
			R3S - Rct. 3-way short				
			R3L - Rct. 3-way long				
			R4 - Rct. 4-way				



# DCD - Directional Ceiling Diffusers

8/2006

## Series 5500 Steel - Model Specification Guide

Square/Rectangular Louver Face Ceiling Diffusers  
Series 5500 - Steel

Directional Ceiling Diffusers



DCD

Model	Available Neck	Air Pattern	Available Finishes	Available Options	
5500S-1 - Flush Surface Mount 5500S-2 - V-Beveled Drop Surface Mount	6" thru 24"	Standard	Standard	D5	Opposed Blade Damper - Steel
		S4 - Sq. 4-way	01 - White	D5A	Opposed Blade Damper - Aluminum
		Options	Optional	L9	Equalizing Grid
		S1 - Sq. 1-way	02 - Aluminum	TR	Square to Round Transition
		S2 - Sq. 2-way	03 - Black	TR Deep	Square to Round Transition - Deep
		S3 - Sq. 3-way	24 - Mill	G3	Equalizing Grid
		SC - Sq. 2-way corner	28 - Custom Color	BDS	Butterfly Damper
		R1S - Rct. 1-way short		RSD	Radial Shutter Damper
		R1L - Rct. 1-way long		IV	Induction Vanes
		R2S - Rct. 2-way short		APD	Air Pattern Deflectors
		R2L - Rct. 2-way long		TR	Transition-Mounted
		R3S - Rct. 3-way short			
		R3L - Rct. 3-way long			
		R4 - Rct. 4-way			

Square/Rectangular Louver Face Ceiling Diffusers  
Series 5500 - Steel  
For T-bar Lay-in Ceiling Grid Applications

Model	Available Neck	Module	Air Pattern	Available Finishes	Available Options	
5500S-6 - T-bar Lay-in 5500S-8 - Tegular T-bar 5500S-9 - Donn Finline	6" thru 21"	12" x 12" 24" x 24"	Standard	Standard	D5	Opposed Blade Damper - Steel
			S4 - Sq. 4-way	01 - White	D5A	Opposed Blade Damper - Aluminum
			Options	Optional	L9	Equalizing Grid
			S1 - Sq. 1-way	02 - Aluminum	TR	Square to Round Transition
			S2 - Sq. 2-way	03 - Black	TR Deep	Square to Round Transition - Deep
			S3 - Sq. 3-way	24 - Mill	G3	Equalizing Grid
			SC - Sq. 2-way corner	28 - Custom Color	BDS	Butterfly Damper
			R1S - Rct. 1-way short		RSD	Radial Shutter Damper
			R1L - Rct. 1-way long		IV	Induction Vanes
			R2S - Rct. 2-way short		APD	Air Pattern Deflectors
			R2L - Rct. 2-way long		TR	Transition-Mounted
			R3S - Rct. 3-way short			
			R3L - Rct. 3-way long			
			R4 - Rct. 4-way			

# LEADING THE INDUSTRY IN PRODUCT LITERATURE

With the choice of our Pre-Flite Catalog, Quick Select Catalog, InfoSource Catalog, InfoSource CD and our web site, [www.metalaire.com](http://www.metalaire.com), you pick the format for product information that best suits your air distribution design needs.

## Pre-Flite - Product Overview Catalog

The METALAIRE Pre-Flite catalog is a condensed reference guide containing concise listings of our entire product line including grilles, registers, diffusers, and air terminal units. This catalog can be used to help select the type of device, along with available border styles. The catalog includes photos of each model along with the features and model guide, a great tool when you are trying to select a device for your project.



## Quick Select Catalog - Air Distribution Selection Made Easy

The METALAIRE Quick Select Catalog is designed to save you time selecting air distribution equipment. This catalog is a compact version of our InfoSource Catalogs and includes drawings and performance for our most popular products. The Quick Select Catalog is broken into product types with each section beginning with a model summary that includes features and benefits of our products. To obtain product information not included in the Quick Select Catalog, simply go to our web site at [www.metalaire.com](http://www.metalaire.com).



## InfoSource Catalog Suite - Complete guide to Air Distribution Selection

The METALAIRE InfoSource Catalog suite is the leading product catalog in the industry. Included in these catalogs are the complete product listings, drawings, product features and benefits, product performance data, specifications, and model specifications. These catalogs are organized to make it quick and easy to find the information you are looking for.

### InfoSource Catalog Suite

- Ceiling Diffusers Catalog
- Grilles & Registers Catalog
- Air Terminal Unit Catalog
- Formations Catalog



## InfoSource CD

Our InfoSource CD has set the standard in the industry for air distribution product selection. This CD contains a complete library of all our catalogs and submittals along with our air terminal unit selection program.



## Web Site: [www.metalaire.com](http://www.metalaire.com)

METALAIRE leads the industry with a web site that contains all the product literature and performance data needed to design your air distribution system. Our web site includes all our submittals, catalogs, installation manuals, as well as as other valuable information to aid you in air distribution design.



# DCD - Directional Ceiling Diffusers

8/2006

## ➔ Economical Square Diffusers ➔ Series 5200 ➔ Aluminum

### Product Details

- ✦ Removable core for concealed mounting
- ✦ Optional built-in opposed blade damper
- ✦ Available in 1 way, 2 way opposite, 2 way corner, 3 way and 4 way directional air patterns



**Model 5200-2 Shown**

Standard Finish: 01 White

Directional Ceiling Diffusers



DCD

Dimensions are in inches

### Economical Square Diffusers - Surface Mount Model 5200-1

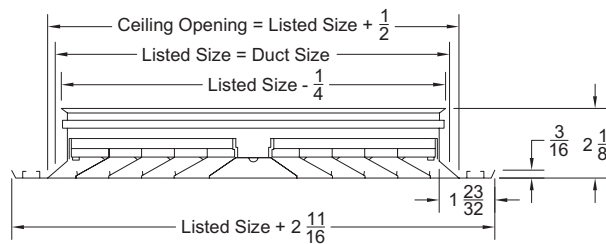

### Economical Square Diffusers - Surface Mount With Opposed Blade Damper Model 5200-1 D

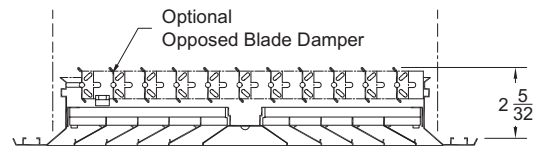

### Economical Square Diffusers - V-Beveled Drop Surface Mounting Model 5200-2

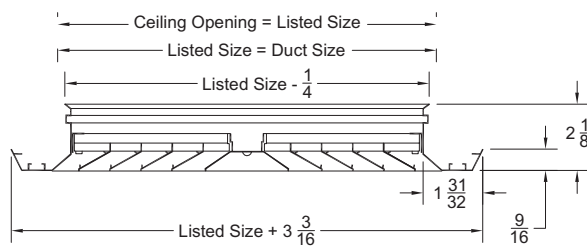

### Economical Square Diffusers - V-Beveled Drop Surface Mounting With Opposed Blade Damper Model 5200-2 D

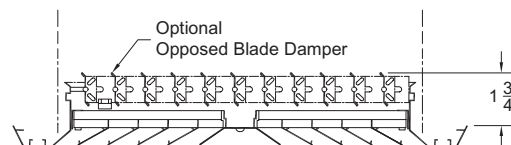

### Economical Square Diffusers - T-bar Lay-in Model 5200-6

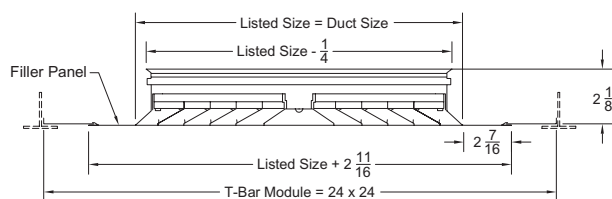

### Economical Square Diffusers - T-bar Lay-in With Opposed Blade Damper Model 5200-6 D

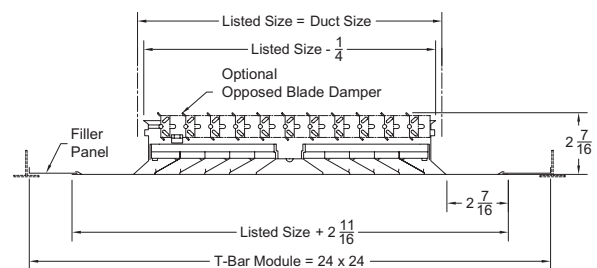



# DCD - Directional Ceiling Diffusers



Air Patterns - Square Economical Face Ceiling Diffusers															
S1 - One Way	S2 - Two Way Opposite	SC - Two Way Corner	S3 - Three Way	S4 - Four Way	Available Sizes										
					<table border="1"> <tr> <td>6" x 6"</td> <td>8" x 8"</td> </tr> <tr> <td>10" x 10"</td> <td>12" x 12"</td> </tr> <tr> <td>14" x 14"</td> <td>16" x 16"</td> </tr> <tr> <td>18" x 18"</td> <td>20" x 20"</td> </tr> <tr> <td>22" x 22"</td> <td>24" x 24"</td> </tr> </table>	6" x 6"	8" x 8"	10" x 10"	12" x 12"	14" x 14"	16" x 16"	18" x 18"	20" x 20"	22" x 22"	24" x 24"
6" x 6"	8" x 8"														
10" x 10"	12" x 12"														
14" x 14"	16" x 16"														
18" x 18"	20" x 20"														
22" x 22"	24" x 24"														

1. Available Finishes	2. Available Accessories	3. Construction Details
<b>Standard Finish:</b> 01 White <b>Optional Finish:</b> 02 Aluminum 28 Custom Color	DA - Opposed Blade Damper - Aluminum .....337	Available Air Pattern: S1, S2, S3, S4 and SC Units are shipped with screw holes as standard

## Series 5200 - Performance

Models 5200 (-1, -2, -6, -1D, -2D, -6D)

CFM	Outlet Size	6 x 6	8 x 8	10 x 10	12 x 12	14 x 14	16 x 16	20 x 20	22 x 22	24 x 24
100	Neck Velocity	400	225	114	100					
	Ps Throw	.004 12 17 14 12	.001 17 14 12 10	.001 14 12 10 9	.001 12 10 8 7					
200	Neck Velocity	800	450	288	200	147				
	Ps Throw	.014 33 27 23 20	.004 27 22 19 16	.002 23 19 16 14	.001 21 17 14 12	.001 18 15 13 11				
300	Neck Velocity		675	432	300	220				
	Ps Throw		.008 35 30 25 22	.004 35 30 25 22	.002 27 22 19 15	.001 24 20 17 15				
400	Neck Velocity		900	576	400	294				
	Ps Throw		.019 47 39 32 29	.008 40 34 28 24	.004 35 30 25 22	.002 32 27 22 19				
600	Neck Velocity			864	600	441	216			
	Ps Throw			.017 52 43 36 32	.008 43 36 30 26	.003 41 34 28 25	.001 30 25 21 19			
800	Neck Velocity				800	588	450	288	238	200
	Ps Throw				.018 57 48 40 35	.008 51 43 36 31	.005 47 39 32 29	.002 40 34 28 24	.001 35 29 24 21	.001 33 27 23 20
1000	Neck Velocity					735	563	360	298	250
	Ps Throw					.014 63 52 43 38	.009 57 48 40 35	.003 49 41 34 30	.002 40 34 28 25	.001 38 32 26 23
1200	Neck Velocity					882	675	432	357	300
	Ps Throw					.019 70 58 48 42	.012 64 53 44 39	.004 55 46 38 33	.002 46 38 32 28	.001 43 36 30 26
1400	Neck Velocity						787	504	417	350
	Ps Throw						.014 63 52 43 38	.005 60 50 41 36	.003 51 43 35 31	.002 48 40 33 29
1600	Neck Velocity						900	576	476	400
	Ps Throw						.020 76 63 52 46	.006 65 54 45 40	.005 61 51 42 37	.003 57 48 40 35
1800	Neck Velocity							648	536	450
	Ps Throw							.006 65 54 45 40	.011 78 65 54 48	.006 76 61 51 45
2000	Neck Velocity							720	595	500
	Ps Throw							.007 70 58 48 42	.008 70 58 48 42	.004 66 55 45 40
2200	Neck Velocity								655	550
	Ps Throw								.009 79 66 55 48	.005 70 58 48 42

### Series 5200 - Performance Notes:

All data are tested in accordance with ANSI/ASHRAE 70-1991

### Definition of Units:

**Neck Velocity** - The neck velocity is in feet per minute (fpm).

**Ps** - Static pressure =  $P_t - P_v$  (inches of water column).

**Throw** - Throws indicated are based on total number of feet of projected air when a terminal velocity of 50 fpm is reached. Numbers reported in chart are, from left to right, for 1,2,3, and 4-way throw patterns.



## Series 5200 - Specifications

5200-1 - Surface Mount  
5200-2 - V-Beveled  
5200-6 - T-bar Lay-in

Air Outlets shall be aluminum model 5200 manufactured by METALAIRE. Units shall consist of a fixed pattern louvered core fastened into a border with spring loaded latches. Core shall be removable without the use of tools. The units shall be the size and quantity as outline in the plans and specifications.

Outlets shall be available in 1, 2-way opposite, 2-way corner, 3, and 4-way directional air patterns.

Units shall be designed to integrate into the specified ceiling system.

### Accessories

#### Optional Dampers:

Aluminum DA opposed blade dampers shall be provided. Damper shall be adjusted using a handle accessible through the face of the diffuser. Screwdriver slot operators are not allowed.

### Performance Specification

The manufacturer shall provide published performance data. Data shall be tested in accordance to ANSI/ASHRAE Standard 70-1991.

### Paint Specification

Process shall be anodic electrodeposition using an anodic acrylic paint. Units shall undergo pre-treatment including a pressurized spray stage using an alkaine cleaner and a de-ionized water rinse.

Film Properties shall meet or exceed the following standards:

Property	Test Method	Performance
Film thickness		.8-1.0 mils
Film Cure		320 F @ 20 min
Gloss – 60 deg.	ASTM D523-89	70-80%
Pencil Hardness	ASTM D3363-92A	HB-H
Crosshatch Adhesion	ASTM D3359-95	4B-5B
Direct Impact	ASTM D2794-93	100 in.lbs. Min
Reverse Impact	ASTM D2794-93	60 in.lbs. Min.
Salt Spray	ASTM B117-95	48-96 Hours
Humidity	ASTM D1735-92	500 Hours
Water Soak	ASTM D870-92	250 Hours



# DCD - Directional Ceiling Diffusers

## Series 5200 - Model Specification Guide

Square Louver Face Ceiling Diffusers  
Aluminum - Series 5200

Model	Available Neck	Air Pattern	Available Finishes	Available Options	
5200-1 - Flush Surface Mount 5200-2 - V-Beveled Drop Surface Mount 5200-4 - Drop Face Surface Mount	6" thru 24"	Standard	Standard	DA	Aluminum - Opposed Blade Damper
		S4 - Sq. 4-way	01 - White		
		Options			
		S1 - Sq. 1-way			
		SC - Sq. 2-way corner			
		S2 - Sq. 2-way			
		S3 - Sq. 3-way			

Square Louver Face Ceiling Diffusers  
Aluminum - Series 5200  
For T-bar Lay-in Ceiling Grid Applications

Model	Available Neck	Module	Air Pattern	Available Finishes	Available Options	
5200-6 - T-bar Lay-in	6" thru 20"	24" x 24"	Standard	Standard	DA	Aluminum - Composed Blade Damper
			S4 - Sq. 4-way	01 - White		
			Options			
			S1 - Sq. 1-way			
			SC - Sq. 2-way corner			
			S2 - Sq. 2-way			
			S3 - Sq. 3-way			



# DCD - Directional Ceiling Diffusers

8/2006

Directional Ceiling Diffusers



DCD

- ➔ Square Face Diffuser ➔ 2-Cone ➔ Round Neck ➔ Series 5700 ➔ Steel
- ➔ Series 5700 AS ➔ Aluminized Steel
- ➔ Series 5700 AL ➔ Steel

## Product Details

- ✦ The 5700 provides a tight horizontal 360° discharge pattern for superior induction and occupant comfort
- ✦ 5700 can be converted in the field to a 3 cone diffuser with the addition of the optional Snap-58
- ✦ Available in metric 600mm x 600mm lay-in
- ✦ Model 5700A is adjustable from horizontal to vertical discharge
- ✦ Lay-in T-bar border 6 can be used in surface mounting applications by adding optional T-bar Plaster Frame (TBPF)
- ✦ The 5700 series is an excellent choice for VAV applications



**Model 5700-6 Shown**

Standard Finish: 01 White

## Aluminized Steel

METALAIRE is proud to announce the availability of aluminized steel for our square Directional Ceiling Diffusers. In environments which demand aluminum's corrosion resistance, the aluminized coated steel offers the protection of aluminum and the strength of steel. The use of aluminized steel results in a product that ships better and that handle better during installation.

### What is Aluminized Steel?

Aluminized steel is continuously hot-dip coated in a bath of commercially pure aluminum to provide a metallurgical bond between the steel substrate and the aluminum coating. The aluminum bath contains 5% to 11% silicon, which is added to minimize growth of a brittle iron-aluminum inter-metallic layer and thus promote coating adherence during forming. This process melds the best features of both metallic materials; the strength and other mechanical properties of the steel substrate and the surface characteristics and corrosion resistance of the aluminum coating.

Aluminized steel has been subjected to long-term testing for resistance to atmospheric corrosion and is proven superior to any other metallic-coated steel. Over forty years of exposure tests in a mild industrial atmosphere show the coating on aluminized steel still protecting the base metal with virtually no detectable loss of the original coating.

## Non - Adjustable

Dimensions are in inches

### Square Face Diffusers - Surface Mount - 24" x 24"

- Model 5700-1 - Steel
- Model 5700-1 AS - Aluminized Steel
- Model 5700-1 AL - Aluminum

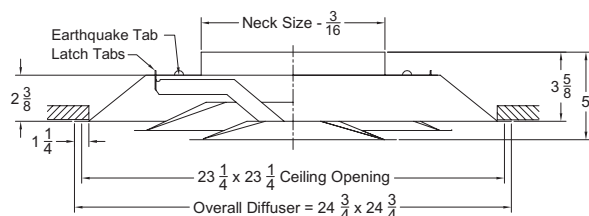

### Square Face Diffusers - Surface Mount - 12" x 12"

- Model 5700-1 - Steel
- Model 5700-1 AS - Aluminized Steel
- Model 5700-1 AL - Aluminum

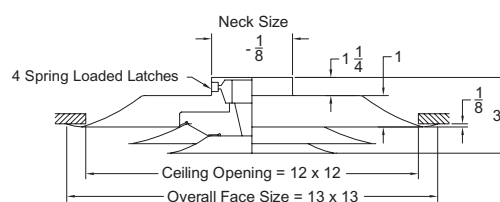

# DCD - Directional Ceiling Diffusers



**Square Face Diffusers - T-Bar Lay-in - 24" x 24"**  
 Model 5700-6 - Steel  
 Model 5700-6 AS - Aluminized Steel  
 Model 5700-6 AL - Aluminum

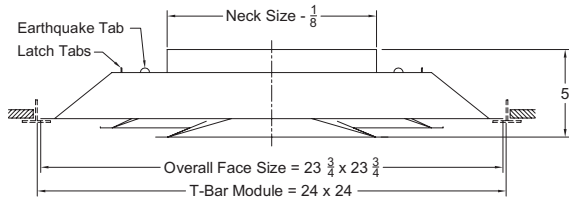

**Square Face Diffusers - T-bar Lay-ins - 12" x 12"**  
 Model 5700-6 - Steel  
 Model 5700-6 AS - Aluminized Steel  
 Model 5700-6 AL - Aluminum

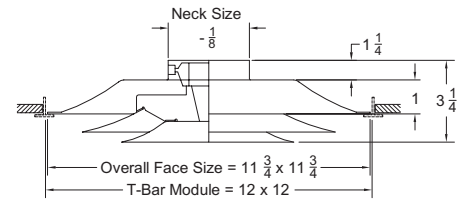

**Square Face Diffusers - T-bar Lay-in Panel - Steel**  
 Model 5700-6P

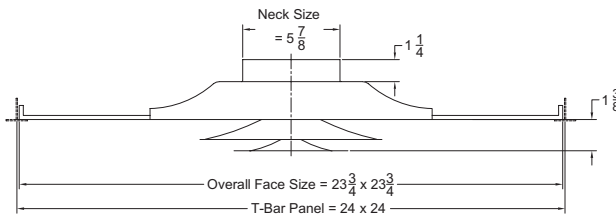

**Square Face Diffusers - Concealed Spline - 24" x 24"**  
 Model 5700-7 - Steel  
 Model 5700-7 AS - Aluminized Steel

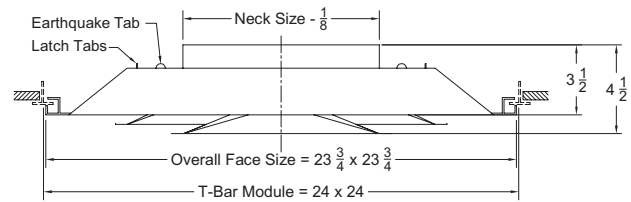

**Square Face Diffusers - Donn Finline - 24" x 24"**  
 Model 5700-9 - Steel  
 Model 5700-9 AS - Aluminized Steel

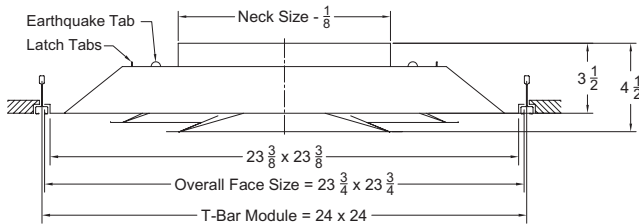

**Metric**

*Dimensions are in millimeters*

**Square Face Diffusers - Metric - T-bar Lay-in - Steel**  
 Model M5700-6 - 600mm x 600mm  
 Model M5700-6 AS - 600mm x 600mm  
 Model M5700-6 AL - 600mm x 600mm

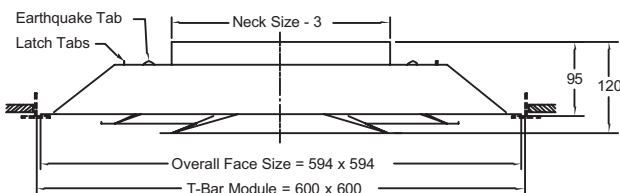

# DCD - Directional Ceiling Diffusers

8/2006

Directional Ceiling Diffusers



DCD

## Adjustable

Dimensions are in inches

### Square Face Diffusers - Surface Mount

Model 5700A-1 - Steel  
 Model 5700A-1 AS- Aluminized Steel  
 Model 5700A-1 AL- Aluminum

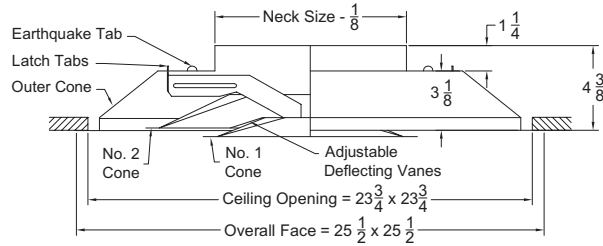

### Square Face Diffusers - T-bar Lay-in

Model 5700A-6 - Steel  
 Model 5700A-6 AS- Aluminized Steel  
 Model 5700A-6 AL- Aluminum

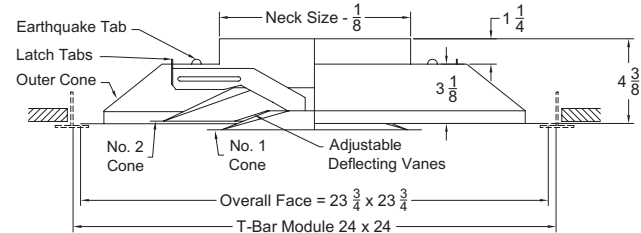

### Square Face Diffusers - Concealed Spline

Model 5700A-7 - Steel  
 Model 5700A-7 AS- Aluminized Steel

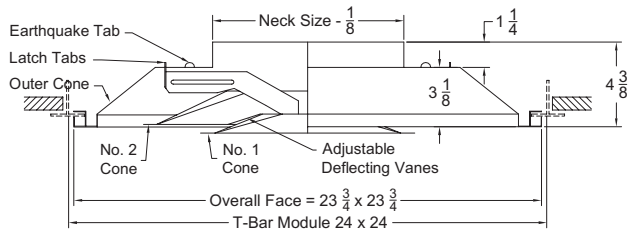

1. Available Finishes	2. Available Accessories	3. Construction Details
<p><b>Standard Finish:</b>                      01 White</p> <p><b>Optional Finish</b>                      03 Black                      28 Custom color</p>	<p>G3 - Equalizing Grid .....337                      BDS - Butterfly Damper .....335                      RSD - Radial Shutter Damper .....336                      SNAP 58 - Converts 5700 from 2 to 3 Cones)                      BAF - Directional Baffles</p> <p><b>Note:</b>                      All Accessories Shipped Unattached</p>	<ul style="list-style-type: none"> <li>Sizes only as listed</li> <li>Available Neck Sizes:                              6, 8, 10, 12, 14 and 15</li> </ul>

# DCD - Directional Ceiling Diffusers

## Series 5700 - Performance

Models 5700 (-1, -6, -7, -9), 5700-6P, 5700 AS (-1,-6,-7,-9), 5700 AL (-1, -6), 5700A (-1, -6, -7), 5700A-1, 5700A-6P

Listed Size	Neck Size Ak	fpm Neck Velocity Pv	400 0.010	500 0.016	600 0.022	700 0.031	800 0.040	900 0.050	1000 0.062	1200 0.090	1400 0.122	2000 0.249
12" x 12"	6 Ak = 0.093	CFM Ps Pt Throw* Throw NC	80 0.021 0.031 2-3-6 3-4-6 -	100 0.033 0.049 3-4-7 3-5-7 <15	120 0.048 0.071 3-5-7 4-5-7 18	135 0.061 0.091 3-5-8 4-6-8 20	155 0.080 0.120 4-6-8 5-6-8 23	175 0.102 0.153 4-6-9 5-6-9 26	195 0.127 0.189 5-7-9 6-7-10 28	235 0.184 0.274 6-7-10 6-8-11 33	275 0.253 0.375 6-8-11 6-8-11 36	395 0.521 0.770 8-9-13 8-10-13 44
		CFM Ps Pt Throw* Throw NC	140 0.029 0.039 3-4-8 3-5-8 -	175 0.046 0.062 3-5-9 4-6-9 <15	210 0.066 0.089 4-6-10 5-7-10 19	245 0.090 0.121 5-7-11 6-7-11 22	280 0.118 0.158 5-8-11 7-8-11 25	315 0.149 0.199 6-8-12 7-8-12 28	350 0.184 0.246 7-9-13 8-10-14 31	420 0.265 0.354 8-10-14 8-10-14 36	490 0.360 0.482 9-11-15 9-11-15 40	700 0.735 0.984 10-13-18 10-13-18 46
24" x 24"	6 Ak = .077	CFM Ps Pt Throw* Throw NC	80 0.014 0.024 2-2-5 2-4-7 -	100 0.021 0.037 2-3-5 3-5-8 -	120 0.031 0.053 2-4-6 4-6-9 -	135 0.039 0.069 3-4-6 4-6-10 <15	155 0.051 0.091 3-4-6 5-7-10 16	175 0.065 0.116 4-5-7 5-8-11 18	195 0.081 0.143 4-5-7 6-8-12 18	235 0.118 0.207 5-6-8 7-9-13 23	275 0.161 0.283 5-6-8 8-10-14 27	395 0.332 0.582 6-7-10 10-12-17 43
		CFM Ps Pt Throw* Throw NC	140 0.016 0.026 2-3-6 3-5-10 -	175 0.025 0.040 3-4-7 4-6-11 -	210 0.036 0.058 3-5-7 5-7-12 -	245 0.048 0.079 4-6-8 6-9-13 -	280 0.063 0.103 4-6-9 6-10-14 <15	315 0.080 0.131 5-6-9 7-10-15 18	350 0.099 0.161 5-7-10 8-11-16 21	420 0.142 0.232 6-7-10 10-12-17 26	490 0.194 0.316 7-8-11 11-13-18 30	700 0.395 0.645 8-10-13 13-16-22 55
	8 Ak = 0.136	CFM Ps Pt Throw* Throw NC	220 0.019 0.029 3-4-8 4-6-12 -	275 0.030 0.046 3-5-8 5-8-14 -	325 0.042 0.064 4-6-9 6-9-15 -	380 0.057 0.088 5-7-10 7-11-16 <15	435 0.075 0.115 5-8-11 8-12-17 16	490 0.096 0.146 6-8-11 8-12-17 20	545 0.118 0.181 7-8-12 9-13-18 24	655 0.171 0.261 8-9-13 10-14-19 30	765 0.233 0.355 8-10-14 13-16-23 35	1090 0.473 0.722 10-12-17 16-19-28 63
		CFM Ps Pt Throw* Throw NC	430 0.026 0.036 4-6-11 6-9-17 -	535 0.041 0.056 5-7-12 7-11-19 -	640 0.058 0.081 6-9-13 8-13-21 <15	750 0.080 0.110 7-10-14 10-15-23 <15	855 0.104 0.144 8-11-15 11-17-24 18	960 0.131 0.181 9-11-16 13-18-26 23	1070 0.163 0.225 10-12-17 14-19-27 28	1285 0.234 0.324 11-13-18 17-21-30 35	1495 0.317 0.440 11-14-20 19-23-32 40	2140 0.650 0.900 14-17-24 22-27-39 57
	10 Ak = 0.213	CFM Ps Pt Throw* Throw NC	490 0.032 0.042 4-6-11 6-9-18 -	615 0.051 0.066 5-8-13 8-11-21 -	735 0.072 0.095 6-9-14 9-14-23 <15	860 0.099 0.130 7-11-15 11-16-24 16	980 0.129 0.169 8-11-16 12-18-26 22	1105 0.164 0.214 9-12-17 14-20-28 27	1225 0.201 0.263 10-13-18 15-21-29 31	1475 0.292 0.381 11-14-20 18-23-32 39	1720 0.396 0.519 12-15-21 20-24-35 46	2455 0.808 1.057 15-18-25 24-29-41 68
		CFM Ps Pt Throw* Throw NC	490 0.032 0.042 4-6-11 6-9-18 -	615 0.051 0.066 5-8-13 8-11-21 -	735 0.072 0.095 6-9-14 9-14-23 <15	860 0.099 0.130 7-11-15 11-16-24 16	980 0.129 0.169 8-11-16 12-18-26 22	1105 0.164 0.214 9-12-17 14-20-28 27	1225 0.201 0.263 10-13-18 15-21-29 31	1475 0.292 0.381 11-14-20 18-23-32 39	1720 0.396 0.519 12-15-21 20-24-35 46	2455 0.808 1.057 15-18-25 24-29-41 68

### Series 5700 - Performance Notes:

All data are tested in accordance with ANSI/ASHRAE 70-1991

### Definition of Units:

- CFM - Cubic Feet per Minute (air)
- fpm - Velocity of air stream in Feet Per Minute
- Pv - Velocity pressure (inches of water column)
- Pt - Total pressure (inches of water column)
- Ps - Static pressure = Pt - Pv (inches of water column)
- Throw\* - Non-isothermal horizontal throw (supply air temperature 15°F colder than average room air temperature) values are for 150 fpm - 100 fpm - 50 fpm velocities
- Throw - Isothermal horizontal throw (supply air temperature the same as average room air temperature) values are for 150 fpm - 100 fpm - 50 fpm velocities
- NC - Noise criterion, sound pressure level. NC ratings are based on sound power level (Lw) RE: 10E-12 watts minus a 10 dB room attenuation in all octave bands
- Ak - Area Factors





## Specifications - Series 5700

- 5700-1 - Surface Mount
- 5700-6 - T-bar Lay-in
- 5700-7 - Concealed Spline
- 5700-9 - Donn Finline Lay-in

### Air Outlets shall be model:

#### Non-Adjustable, Horizontal Discharge Pattern

5700 manufactured by METALAIR. Units shall be constructed of steel.  
 5700 AS manufactured by METALAIR. Units shall be constructed of aluminized steel.  
 5700 AL manufactured by METALAIR. Units shall be constructed of aluminum.

#### Adjustable Discharge Pattern

5700A manufactured by METALAIR. Units shall be constructed of steel.  
 5700A AS manufactured by METALAIR. Units shall be constructed of aluminized steel.  
 5700A AL manufactured by METALAIR. Units shall be constructed of aluminum.

Units shall be square with a formed backpan and two inner cones. Outlet shall have the same appearance from the face regardless of inlet size. The units shall be the size and quantity as outline in the plans and specifications.

Inlets shall be drawn into the backpan of the diffuser. Welded inlets are not acceptable. Diffusers shall include seismic tabs drawn into the backpan.

The bottom cone shall have a removable plug in the center to allow access to adjust an optional damper. Units shall include the option to allow a field installed third optional cone accessory model Snap-58. Optional third cone shall be installed into the bottom of the 5700 diffuser without the use of tools.

Units shall be designed to integrate into the specified ceiling system.

#### Optional for Adjustable Pattern

Outlet shall include adjustable deflector blades located within the cones of the device. Deflectors shall allow the discharge air to be adjusted to obtain a vertical or horizontal air pattern.

### Optional Dampers and Accessories

#### Butterfly Damper

METALAIR model BDS aluminum round butterfly type dampers shall be provided. Damper shall consist of two butterfly style blades that can be adjusted from full open to full closed. Damper shall be adjusted with a screw driver slot that can be assessed through the face of the diffuser.

#### Radial Shutter Damper

METALAIR model RSD steel round radial shutter damper shall be provided. Damper shall consist of gang operated radial blades that slide perpendicular to air flow direction. The damper shall be adjusted from full open to full closed. Damper shall be adjusted with a screw driver slot that can be assessed through the face of the diffuser.

#### Equalizing Grid

METALAIR model G3 aluminum round equalizing grid shall be provided. Equalizing grid shall consist of 1/2" x 1/2" x 1/2" aluminum cubed core mounting in an aluminum frame.

### Paint Specification

Process shall be anodic electrodeposition using an anodic acrylic paint. Units shall undergo pre-treatment including a pressurized spray stage using an alkaine cleaner and a de-ionized water rinse.

Film Properties shall meet or exceed the following standards:

Property	Test Method	Performance
Film thickness		.8-1.0 mils
Film Cure		320 F @ 20 min
Gloss – 60 deg.	ASTM D523-89	70-80%
Pencil Hardness	ASTM D3363-92A	HB-H
Crosshatch Adhesion	ASTM D3359-95	4B-5B
Direct Impact	ASTM D2794-93	100 in.lbs. Min
Reverse Impact	ASTM D2794-93	60 in.lbs. Min.
Salt Spray	ASTM B117-95	48-96 Hours
Humidity	ASTM D1735-92	500 Hours
Water Soak	ASTM D870-92	250 Hours

# DCD - Directional Ceiling Diffusers

## Series 5700 - Model Specification Guide

### Square Face Diffusers - 2 Cone - Series 5700

Model	Available Neck	Module	Available Finishes	Available Options	
5700-1 - Surface Mount - Steel 5700-1 AS - Surface Mount - Aluminized Steel 5700-1 AL - Surface Mount - Aluminum 5700A-1 - Adjustable - Surface Mount - Steel 5700A-1 AS - Adjustable - Surface Mount - Aluminized Steel 5700-6 - T-bar Lay-in - Steel 5700-6 AS - T-bar Lay-in - Aluminized Steel 5700-6 AL - T-bar Lay-in - Aluminum 5700A-6 - Adjustable T-bar Lay-in Steel 5700A-6 AS - Adjustable T-bar Lay-in - Aluminized Steel 5700A-6 AL - Adjustable T-bar Lay-in - Aluminum	6" 8" 10" 12" 14" 15"	12" x 12" 24" x 24"	Standard	G3	Equalizing Grid
			01 - White	BDS	Butterfly Damper
			Optional	RSD	Radial Shutter Damper
			03 - Black	BAF-1	1 Way Directional Baffle
			28 - Custom Color	BAF-2	2 Way Directional Baffle
				BAF-3	3 Way Directional Baffle

Model	Available Neck	Module	Available Finishes	Available Options	
5700-7 - Concealed T-bar - Steel 5700-7 AS - Concealed T-bar - Aluminized Steel 5700A-7 - Concealed T-bar - Aluminized Steel 5700A-7 AS - Adjustable T-bar Lay-in - Aluminized Steel 5700-9 - Donn Finline - Steel 5700-9 AS - Donn Finline - Aluminized Steel	6" 8" 10" 12" 14" 15"	24" x 24"	Standard	G3	Equalizing Grid
			01 - White	BDS	Butterfly Damper
			Optional	RSD	Radial Shutter Damper
			03 - Black	BAF-1	1 Way Directional Baffle
			28 - Custom Color	BAF-2	2 Way Directional Baffle
				BAF-3	3 Way Directional Baffle

Model	Available Neck	Module	Available Finishes	Available Options	
M5700-6 - Metric T-bar Lay-in - Steel M5700-6 AS - Metric T-bar Lay-in - Aluminized Steel M5700-6 AL - Metric T-bar Lay-in - Aluminum	6" 8" 10" 12" 14" 15"	600mm x 600mm	Standard	G3	Equalizing Grid
			01 - White	BDS	Butterfly Damper
			Optional	RSD	Radial Shutter Damper
			03 - Black	BAF-1	1 Way Directional Baffle
			28 - Custom Color	BAF-2	2 Way Directional Baffle
				BAF-3	3 Way Directional Baffle





- ➔ Square Panel Face ➔ Series 5750 ➔ Steel
- ➔ Series 5750 AS ➔ Aluminized Steel

## Product Details

- ★ Attractive single panel design blends well with all ceilings
- ★ The 5750 provides a tight 360° discharge pattern for superior induction and occupant comfort
- ★ Available in metric lay-in 600mm x 600mm
- ★ Lay-in T-bar border 6 can be used in surface mounting applications by adding optional T-bar Plaster Frame (TBPF)
- ★ Face panel is easy to remove without tools
- ★ The 5750 is an excellent choice for VAV applications



**Model 5750-6 Shown**  
Standard Finish: 01 White

## Aluminized Steel

METALAIRES is proud to announce the availability of aluminized steel for our square Directional Ceiling Diffusers. In environments which demand aluminum's corrosion resistance, the aluminized coated steel offers the protection of aluminum and the strength of steel. The use of aluminized steel results in a product that ships better and that handle better during installation.

### What is Aluminized Steel?

Aluminized steel is continuously hot-dip coated in a bath of commercially pure aluminum to provide a metallurgical bond between the steel substrate and the aluminum coating. The aluminum bath contains 5% to 11% silicon, which is added to minimize growth of a brittle iron-aluminum inter-metallic layer and thus promote coating adherence during forming. This process melds the best features of both metallic materials; the strength and other mechanical properties of the steel substrate and the surface characteristics and corrosion resistance of the aluminum coating.

Aluminized steel has been subjected to long-term testing for resistance to atmospheric corrosion and is proven superior to any other metallic-coated steel. Over forty years of exposure tests in a mild industrial atmosphere show the coating on aluminized steel still protecting the base metal with virtually no detectable loss of the original coating.

Dimensions are in inches

### Square Face - Round Neck - Uni-Flow Panel Face

Surface Mount - 24" x 24"

Model 5750-1 - Steel  
Model 5750-1 AS - Aluminized Steel

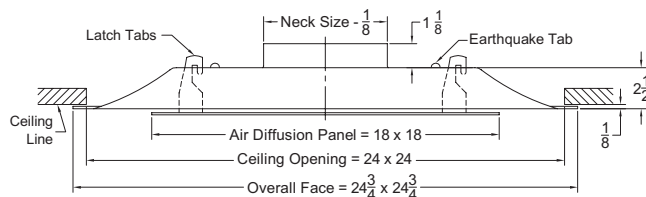

### Square Face - Round Neck - Uni-Flow Panel Face

Surface Mount - 12" x 12"

Model 5750-1 - Steel  
Model 5750-1 AS - Aluminized Steel

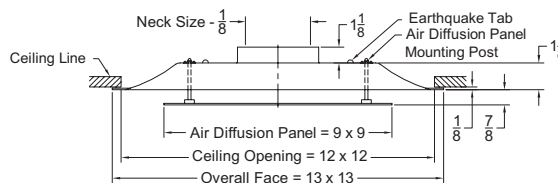



# DCD - Directional Ceiling Diffusers



**Square Face - Round Neck - Uni-Flow Panel Face**  
**T-bar Lay-in - 24" x 24"**  
 Model 5750-6 - Steel  
 Model 5750-6 AS - Aluminized Steel

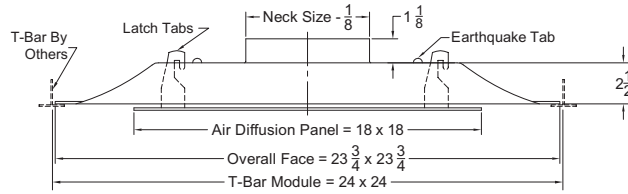

**Square Face - Round Neck - Uni-Flow Panel Face**  
**T-bar Lay-in - 12" x 12"**  
 Model 5750-6 - Steel  
 Model 5750-6 AS - Aluminized Steel

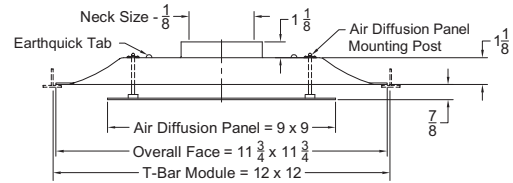

**Square Face - Round Neck - Uni-Flow Panel Face**  
**Concealed Spline - 24" x 24"**  
 Model 5750-7 - Steel  
 Model 5750-7 AS - Aluminized Steel

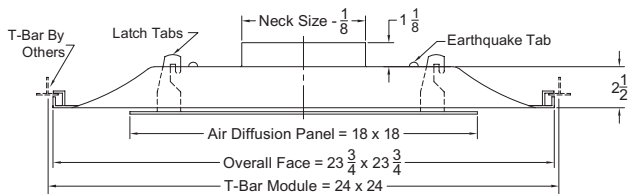

**Square Face - Round Neck - Uni-Flow Panel Face**  
**Donn Finline - 12" x 12"**  
 Model 5750-9 - Steel  
 Model 5750-9 AS - Aluminized Steel

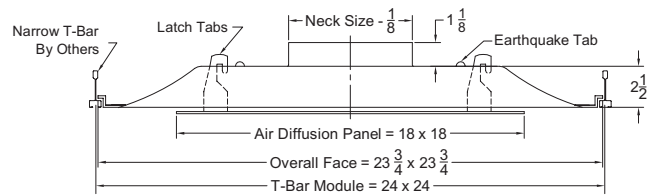

**Metric**

*Dimensions are in millimeters*

**Square Face - Round Neck - Uni-Flow Panel Face - Metric**  
**T-bar Lay-in**  
 Model M5750-6 - Steel  
 Model M5750-6 AS - Aluminized Steel

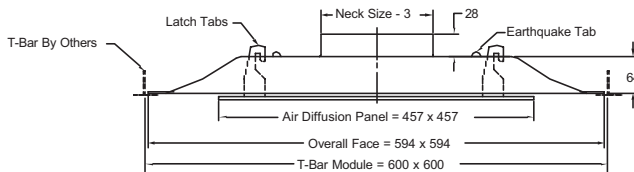

1. Available Finishes	2. Available Accessories	3. Construction Details
<p><b>Standard Finish:</b>                      01 White</p> <p><b>Optional Finish</b>                      03 Black                      28 Custom color</p>	<p>G3 - Equalizing Grid .....337                      BDS - Butterfly Damper .....335                      RSD - Radial Shutter Damper .....336                      BAF - Directional Baffles                      BO - Blank off for 5750</p> <p><b>Note:</b>                      All Accessories Shipped Unattached</p>	<ul style="list-style-type: none"> <li>Sizes only as listed</li> <li>Available Neck Sizes:                              6" and 8" for 12" x 12" Module                              6", 8", 10", 12", 14", and 15" for 24" x 24" Module.</li> </ul>

# DCD - Directional Ceiling Diffusers

## Series 5750 - Performance

Models 5750 (-1, -2, -7, -9) 5750 AS (-1, -6, -7, -9)

Directional Ceiling Diffusers



DCD

Listed Size	Neck Size Ak	fpm Neck Velocity Pv	400 0.010	500 0.016	600 0.022	700 0.031	800 0.040	900 0.050	1000 0.062	1200 0.090	1400 0.122	2000 0.249
12" x 12"	6 Ak = 0.093	CFM Ps Pt Throw* Throw NC	80 0.009 0.019 3-4-7 3-4-7 <15	100 0.014 0.030 3-5-7 4-5-7 <15	120 0.021 0.043 4-6-8 4-6-8 <15	135 0.024 0.054 4-6-9 5-6-9 16	155 0.032 0.072 5-6-9 5-7-9 18	175 0.041 0.092 6-7-10 6-7-10 21	195 0.051 0.114 6-7-10 6-7-10 23	235 0.075 0.165 6-8-11 7-8-11 27	275 0.104 0.226 7-9-12 7-9-12 31	315 0.137 0.297 8-9-13 8-9-13 34
	8 Ak = 0.165	CFM Ps Pt Throw* Throw NC	140 0.017 0.027 3-5-9 4-6-9 <15	175 0.027 0.043 4-7-10 5-7-10 <15	210 0.039 0.061 5-8-11 6-8-11 17	245 0.053 0.083 6-8-11 7-8-12 20	280 0.069 0.109 7-9-12 7-9-13 22	315 0.087 0.138 8-9-13 8-9-13 25	350 0.108 0.170 8-10-14 8-10-14 27	420 0.155 0.245 9-11-15 9-11-15 31	490 0.212 0.334 10-12-17 10-12-17 34	560 0.276 0.436 10-12-17 10-13-18 37
24" x 24"	6 Ak = .077	CFM Ps Pt Throw* Throw NC	80 0.003 0.013 0-1-4 1-2-5 <15	100 0.004 0.020 1-2-6 1-3-6 <15	120 0.006 0.029 1-2-7 2-4-7 <15	135 0.006 0.036 1-3-8 2-4-8 <15	155 0.008 0.048 2-4-8 3-5-9 15	175 0.011 0.061 2-5-9 4-5-9 18	195 0.014 0.076 3-5-9 4-6-10 21	235 0.021 0.110 4-7-10 5-7-11 26	275 0.029 0.151 5-8-11 6-8-12 31	315 0.039 0.198 6-9-12 6-9-13 35
	8 Ak = 0.136	CFM Ps Pt Throw* Throw NC	140 0.007 0.017 1-1-6 1-2-6 <15	175 0.012 0.027 1-2-7 2-4-8 <15	210 0.017 0.039 1-3-9 2-5-10 <15	245 0.023 0.053 2-4-10 3-6-11 17	280 0.030 0.070 3-6-11 4-6-12 21	315 0.038 0.088 3-7-12 5-7-13 25	350 0.047 0.109 4-7-13 5-8-13 28	420 0.067 0.157 6-9-14 6-10-14 34	490 0.091 0.213 7-10-15 7-11-16 39	560 0.119 0.279 8-11-16 9-12-17 42
	10 Ak = 0.213	CFM Ps Pt Throw* Throw NC	220 0.016 0.026 1-2-7 1-3-8 <15	275 0.025 0.040 1-3-9 2-5-10 <15	325 0.034 0.056 2-4-11 3-6-12 15	380 0.047 0.077 2-5-13 4-7-14 21	435 0.061 0.101 3-7-14 5-8-15 26	490 0.078 0.128 4-8-15 6-9-16 30	545 0.096 0.159 5-9-16 7-10-17 33	655 0.139 0.229 7-11-17 8-12-18 37	765 0.190 0.313 9-13-19 9-14-20 41	875 0.249 0.409 10-14-20 11-15-21 43
	12 Ak = 0.307	CFM Ps Pt Throw* Throw NC	315 0.027 0.037 1-2-9 2-4-10 <15	395 0.042 0.058 1-3-11 2-6-12 <15	470 0.059 0.082 2-5-13 4-7-14 17	550 0.081 0.112 3-7-15 5-8-17 22	630 0.107 0.146 4-9-17 6-10-18 27	705 0.133 0.183 5-10-18 7-11-19 30	785 0.165 0.227 6-11-19 8-12-20 33	940 0.236 0.326 8-13-21 10-14-22 38	1100 0.324 0.446 10-15-23 11-17-23 42	1255 0.422 0.581 12-17-24 13-18-25 45
	14 Ak = 0.418	CFM Ps Pt Throw* Throw NC	430 0.031 0.041 1-3-10 2-4-11 <15	535 0.049 0.064 2-4-13 3-6-14 <15	640 0.069 0.092 2-6-15 4-8-17 20	750 0.095 0.126 3-8-18 6-10-19 25	855 0.124 0.164 4-10-20 7-11-21 30	960 0.156 0.206 6-12-21 8-13-22 33	1070 0.194 0.256 7-13-22 9-14-23 36	1285 0.280 0.370 10-15-24 11-17-25 40	1495 0.378 0.501 12-18-26 13-19-27 44	1710 0.495 0.655 14-20-28 15-21-29 46
	15 Ak = 0.479	CFM Ps Pt Throw* Throw NC	490 0.038 0.048 1-3-11 2-4-12 <15	615 0.060 0.076 2-4-14 3-7-15 <15	735 0.086 0.108 3-6-16 4-9-18 20	860 0.117 0.148 4-8-19 6-10-21 27	980 0.152 0.192 5-11-21 8-12-22 32	1105 0.194 0.244 6-12-23 9-13-24 35	1225 0.238 0.300 7-14-24 10-15-25 37	1475 0.345 0.435 11-17-26 12-18-27 41	1720 0.469 0.592 13-19-28 14-21-29 44	1965 0.613 0.772 15-21-30 16-22-31 47

### Series 5750 - Performance Notes:

All data are tested in accordance with ANSI/ASHRAE 70-1991

### Definition of Units:

- CFM - Cubic Feet per Minute (air)
- fpm - Velocity of air stream in Feet Per Minute
- Pv - Velocity pressure (inches of water column)
- Pt - Total pressure (inches of water column)
- Ps - Static pressure = Pt - Pv (inches of water column)
- Throw\* - Non-isothermal horizontal throw (supply air temperature 15°F colder than average room air temperature) values are for 150 fpm - 100 fpm - 50 fpm velocities
- Throw - Isothermal horizontal throw (supply air temperature the same as average room air temperature) values are for 150 fpm - 100 fpm - 50 fpm velocities
- NC - Noise criterion, sound pressure level. NC ratings are based on sound power level (Lw) RE: 10E-12 watts minus a 10 dB room attenuation in all octave bands
- Ak - Area Factors

## Series 5750 - Specifications

- 5750-1 - Surface Mount
- 5750-6 - T-bar Lay-in
- 5750-7 - Concealed Spline
- 5750-9 - Donn Finline Lay-in

### Air Outlets shall be model:

5750 manufactured by METALAIRES. Units shall be constructed of steel.  
5750 AS manufactured by METALAIRES. Units shall be constructed of aluminized steel.

Units shall be square with a formed backpan and a flat face panel. Face panel shall project no more than 1/4" below the ceiling grid or surface. Outlet shall have the same appearance from the face regardless of inlet size. The units shall be the size and quantity as outline in the plans and specifications.

Inlets shall be drawn into the backpan of the diffuser. Welded inlets are not acceptable. Diffusers shall include seismic tabs drawn into the backpan. Face panel shall be removable without the aid of tools for installation and to access optional damper. Units requiring tools to remove the inner cones are not acceptable.

Units shall be designed to integrate into the specified ceiling system.

### Optional Dampers and Accessories

#### **Butterfly Damper**

METALAIRES model BDS aluminum round butterfly type dampers shall be provided. Damper shall consist of two butterfly style blades that can be adjusted from full open to full closed. Damper shall be adjusted with a screw driver slot that can be assessed through the face of the diffuser.

#### **Radial Shutter Damper**

METALAIRES model RSD steel round radial shutter damper shall be provided. Damper shall consist of gang operated radial blades that slide perpendicular to air flow direction. The damper shall be adjusted from full open to full closed. Damper shall be adjusted with a screw driver slot that can be assessed through the face of the diffuser.

#### **Opposed Blade Damper**

METALAIRES model D3 aluminum or SD3 Steel round opposed blade type dampers shall be provided. Damper shall consist of gang operated blades that can be adjusted from full open to full closed. Damper shall be adjusted with a screw driver slot that can be assessed through the face of the diffuser.

#### **Equalizing Grid**

METALAIRES model G3 aluminum round equalizing grid shall be provided. Equalizing grid shall consist of 1/2" x 1/2" x 1/2" aluminum cubed core mounting in an aluminum frame.

### Paint Specification

Process shall be anodic electrodeposition using an anodic acrylic paint. Units shall undergo pre-treatment including a pressurized spray stage using an alkaine cleaner and a de-ionized water rinse.

Film Properties shall meet or exceed the following standards:

Property	Test Method	Performance
Film thickness		.8-1.0 mils
Film Cure		320 F @ 20 min
Gloss – 60 deg.	ASTM D523-89	70-80%
Pencil Hardness	ASTM D3363-92A	HB-H
Crosshatch Adhesion	ASTM D3359-95	4B-5B
Direct Impact	ASTM D2794-93	100 in.lbs. Min
Reverse Impact	ASTM D2794-93	60 in.lbs. Min.
Salt Spray	ASTM B117-95	48-96 Hours
Humidity	ASTM D1735-92	500 Hours
Water Soak	ASTM D870-92	250 Hours



# DCD - Directional Ceiling Diffusers

8/2006

## Series 5750 - Model Specification Guide

### Square Face Diffusers - Round Neck - Uni-Flo Panel Face - Series 5750

Directional Ceiling Diffusers



DCD

Model	Available Neck	Module	Available Finishes	Available Options	
5750-1 - Surface Mount - Steel 5750-1 AS - Surface Mount - Aluminized Steel 5750-6 - T-bar Lay-in - Steel 5750-6 AS - T-bar Lay-in - Aluminized Steel	6" 8" 10" 12" 14" 15"	12" x 12" 24" x 24"	Standard	G3	Equalizing Grid
			01 - White	BDS	Butterfly Damper
			Options	RSD	Radial Shutter Damper
			03 - Black	BAF-1	1 Way Directional Baffle
			28 - Custom Color	BAF-2	2 Way Directional Baffle
				BAF-3	3 Way Directional Baffle
				BO	Blank-Off
	D3	Round Opposed Blade Damper - Aluminum			
	SD3	Round Opposed Blade Damper - Steel			

Model	Available Neck	Module	Available Finishes	Available Options	
5750-7 - Concealed T-bar - Steel 5750-7 AS - Concealed T-bar - Aluminized Steel 5750-9 - Donn Finline - Steel 5750-9 AS - Donn Finline - Aluminized Steel	6" 8" 10" 12" 14" 15"	24" x 24"	Standard	G3	Equalizing Grid
			01 - White	BDS	Butterfly Damper
			Options	RSD	Radial Shutter Damper
			03 - Black	BAF-1	1 Way Directional Baffle
			28 - Custom Color	BAF-2	2 Way Directional Baffle
				BAF-3	3 Way Directional Baffle
				BO	Blank-Off
	D3	Round Opposed Blade Damper - Aluminum			
	SD3	Round Opposed Blade Damper - Steel			

Model	Available Neck	Module	Available Finishes	Available Options	
M5750-6 - Metric T-bar Lay-in - Steel M5750-6 AS - Metric T-bar Lay-in - Aluminized Steel	6" 8" 10" 12" 14" 15"	600mm x 600mm	Standard	G3	Equalizing Grid
			01 - White	BDS	Butterfly Damper
			Options	RSD	Radial Shutter Damper
			03 - Black	BAF-1	1 Way Directional Baffle
			28 - Custom Color	BAF-2	2 Way Directional Baffle
				BAF-3	3 Way Directional Baffle
				BO	Blank-Off
	D3	Round Opposed Blade Damper - Aluminum			
	SD3	Round Opposed Blade Damper - Steel			

# LEADING THE INDUSTRY IN PRODUCT LITERATURE

With the choice of our Pre-Flite Catalog, Quick Select Catalog, InfoSource Catalog, InfoSource CD and our web site, [www.metalaire.com](http://www.metalaire.com), you pick the format for product information that best suits your air distribution design needs.

## Pre-Flite - Product Overview Catalog

The METALAIRES Pre-Flite catalog is a condensed reference guide containing concise listings of our entire product line including grilles, registers, diffusers, and air terminal units. This catalog can be used to help select the type of device, along with available border styles. The catalog includes photos of each model along with the features and model guide, a great tool when you are trying to select a device for your project.

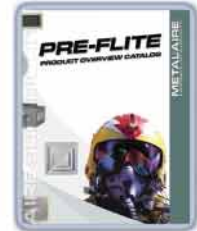

## Quick Select Catalog - Air Distribution Selection Made Easy

The METALAIRES Quick Select Catalog is designed to save you time selecting air distribution equipment. This catalog is a compact version of our InfoSource Catalogs and includes drawings and performance for our most popular products. The Quick Select Catalog is broken into product types with each section beginning with a model summary that includes features and benefits of our products. To obtain product information not included in the Quick Select Catalog, simply go to our web site at [www.metalaire.com](http://www.metalaire.com).



## InfoSource Catalog Suite - Complete guide to Air Distribution Selection

The METALAIRES InfoSource Catalog suite is the leading product catalog in the industry. Included in these catalogs are the complete product listings, drawings, product features and benefits, product performance data, specifications, and model specifications. These catalogs are organized to make it quick and easy to find the information you are looking for.

### InfoSource Catalog Suite

- Ceiling Diffusers Catalog
- Grilles & Registers Catalog
- Air Terminal Unit Catalog
- Formations Catalog



## InfoSource CD

Our InfoSource CD has set the standard in the industry for air distribution product selection. This CD contains a complete library of all our catalogs and submittals along with our air terminal unit selection program.



## Web Site: [www.metalaire.com](http://www.metalaire.com)

METALAIRES leads the industry with a web site that contains all the product literature and performance data needed to design your air distribution system. Our web site includes all our submittals, catalogs, installation manuals, as well as as other valuable information to aid you in air distribution design.



**METALAIRES**  
EXPERIENCE AIRE SUPERIORITY.

# DCD - Directional Ceiling Diffusers

8/2006

Directional Ceiling Diffusers



DCD

- ➔ Square Louver Face ➔ Series 5800 ➔ Steel
- ➔ Series 5800 AS ➔ Aluminized Steel
- ➔ Series 5800 AL ➔ Aluminum

## Product Details

- ✦ The 5800 provides a tight 360° discharge pattern for superior induction and occupant comfort
- ✦ Available in metric 600mm x 600mm lay-in
- ✦ 5800A can be adjusted from horizontal to vertical discharge
- ✦ Lay-in T-bar border 6 can be used in surface mounting applications by adding optional T-bar Plaster Frame (TBPF)
- ✦ The 5800 is an excellent choice for VAV applications



**Model 5800-6 Shown**  
Standard Finish: 01 White

## Aluminized Steel

METALAIRE is proud to announce the availability of aluminized steel for our square Directional Ceiling Diffusers. In environments which demand aluminum's corrosion resistance, the aluminized coated steel offers the protection of aluminum and the strength of steel. The use of aluminized steel results in a product that ships better and that handles better during installation.

### What is Aluminized Steel?

Aluminized steel is continuously hot-dip coated in a bath of commercially pure aluminum to provide a metallurgical bond between the steel substrate and the aluminum coating. The aluminum bath contains 5% to 11% silicon, which is added to minimize growth of a brittle iron-aluminum inter-metallic layer and thus promote coating adherence during forming. This process melds the best features of both metals; the strength and other mechanical properties of the steel substrate and the surface characteristics and corrosion resistance of aluminum.

Aluminized steel has been subjected to long-term testing for resistance to atmospheric corrosion and is proven superior to any other metallic-coated steel. Over forty years of exposure tests in a mild industrial atmosphere show the coating on aluminized steel still protecting the base metal with virtually no detectable loss of the original coating.

## Non-Adjustable

Dimensions are in inches

### Square Face - Round Neck - 3 Cone - Surface Mount - 24" x 24"

- Model 5800-1 - Steel
- Model 5800-1 AS - Aluminized Steel
- Model 5800-1 AL - Aluminum

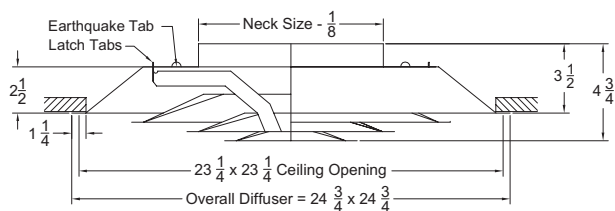

Available Neck Sizes 6, 8, 10, 12, 14, 15

### Square Face - Round Neck - 3 Cone - Surface Mount - 12" x 12"

- Model 5800-1 - Steel
- Model 5800-1 AS - Aluminized Steel

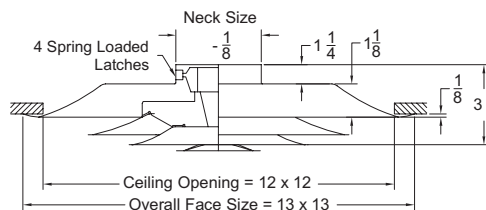

Available Neck Sizes 6, 8

# DCD - Directional Ceiling Diffusers



## Square Face - Round Neck - 3 Cone - T-bar Lay-in - 24" x 24"

Model 5800-6 - Steel  
 Model 5800-6 AS - Aluminized Steel  
 Model 5800-6 AL - Aluminum

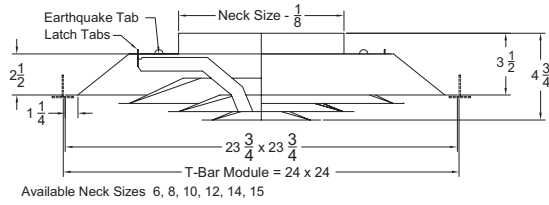

## Square Face - Round Neck - 3 Cone - T-bar Lay-in - 12" x 12"

Model 5800-6 - Steel  
 Model 5800-6 AS - Aluminized Steel

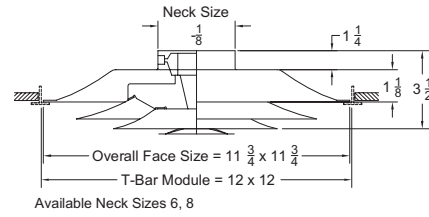

## Square Face - Round Neck - 3 Cone - T-bar Lay-in Panel - 24" x 24"

Model 5800-6P - Steel

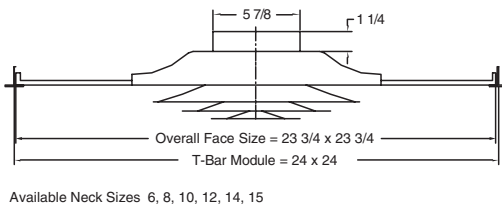

## Square Face - Round Neck - 3 Cone - Concealed Spline - 24" x 24"

Model 5800-7 - Steel  
 Model 5800-7 AS - Aluminized Steel

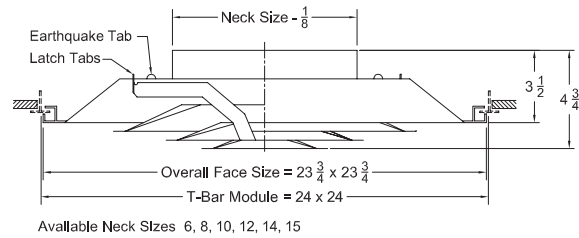

## Metric

Dimensions are in millimeters

## Square Face - Round Neck - 3 Cone - T-bar Lay-in - Metric

Model M5800-6 - Steel  
 Model M5800-6 AS - Aluminized Steel  
 Model M5800-6 AS - Aluminized Steel

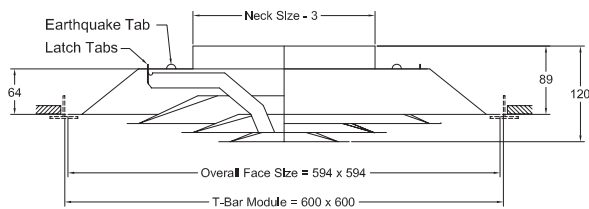



# DCD - Directional Ceiling Diffusers

8/2006

Directional Ceiling Diffusers



DCD

## Adjustable

Dimensions are in inches

**Square Face - Round Neck - 3 Cone - Surface Mount - Adjustable**  
 Model 5800A-1 - Steel  
 Model 5800A-1 AS - Aluminized Steel

**Square Face - Round Neck - 3 Cone - T-bar Lay-in - Adjustable**  
 Model 5800A-6 - Steel  
 Model 5800A-6 AS - Aluminized Steel

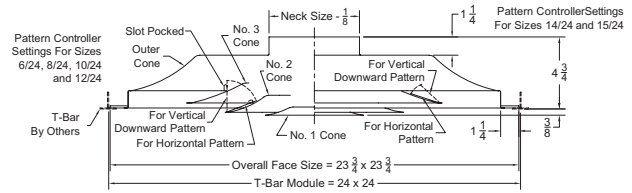
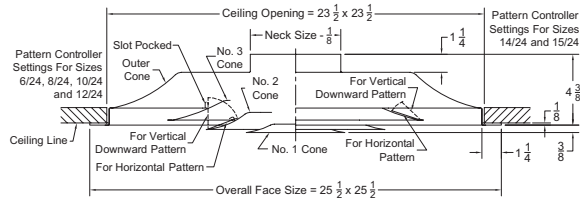

1. Available Finishes	2. Available Accessories	3. Construction Details
<p><b>Standard Finish:</b>                      01 White</p> <p><b>Optional Finish</b>                      03 Black                      28 Custom color</p>	<p><b>G3</b> - Equalizing Grid .....337  <b>BDS</b> - Butterfly Damper .....335  <b>RSD</b> - Radial Shutter Damper .....336  <b>BAF</b> - Directional Baffles</p> <p><b>Note:</b>                      All Accessories Shipped Unattached</p>	<ul style="list-style-type: none"> <li>Sizes only as listed</li> <li>Available Neck Sizes: 6, 8, 10, 12, 14 and 15</li> <li>Available Neck Sizes: 6" and 8" for 12" x 12" Module</li> </ul>



# DCD - Directional Ceiling Diffusers

## Series 5800 - Performance

Models 5800 (-1, -6, -7), 5800-6P, 5800 AS (-1,-6, -7), 5800 AL (-1, -6)

Listed Size	Neck Size Ak	fpm Neck Velocity Pv	400 0.010	500 0.016	600 0.022	700 0.031	800 0.040	900 0.050	1000 0.062	1200 0.090	1400 0.122	2000 0.249
12" x 12"	6 Ak = 0.093	CFM	80	100	120	135	155	175	195	235	275	315
		Ps	0.026	0.040	0.058	0.073	0.097	0.123	0.153	0.223	0.305	0.400
		Pt	0.036	0.056	0.080	0.104	0.137	0.174	0.216	0.312	0.427	0.559
		Throw*	3-4-6	3-5-7	4-5-7	4-6-8	5-6-8	5-6-9	5-7-9	6-7-10	6-8-11	7-9-12
12" x 12"	8 Ak = 0.165	CFM	140	175	210	245	280	315	350	420	490	560
		Ps	0.026	0.041	0.059	0.080	0.104	0.132	0.163	0.235	0.319	0.417
		Pt	0.036	0.056	0.081	0.110	0.144	0.182	0.225	0.324	0.442	0.577
		Throw*	3-5-8	4-6-9	5-7-10	6-8-11	7-8-11	7-9-12	7-9-13	8-10-14	9-11-15	9-11-16
12" x 12"	6 Ak = .077	CFM	80	100	120	135	155	175	195	235	275	315
		Ps	0.013	0.020	0.029	0.037	0.048	0.061	0.076	0.111	0.152	0.199
		Pt	0.023	0.036	0.051	0.067	0.088	0.112	0.139	0.201	0.274	0.359
		Throw*	3-4-5	3-4-6	4-5-7	4-5-7	4-5-7	5-6-8	5-6-8	5-6-9	6-7-10	6-7-11
12" x 12"	8 Ak = 0.136	CFM	140	175	210	245	280	315	350	420	490	560
		Ps	0.014	0.022	0.032	0.043	0.056	0.071	0.088	0.126	0.172	0.225
		Pt	0.024	0.038	0.054	0.074	0.096	0.122	0.150	0.216	0.294	0.384
		Throw*	4-5-7	5-6-8	5-6-9	5-7-9	6-7-10	6-7-11	6-8-11	7-9-12	8-9-13	8-10-14
24" x 24"	6 Ak = 0.213	CFM	220	275	325	380	435	490	545	655	765	875
		Ps	0.018	0.028	0.039	0.053	0.070	0.088	0.109	0.158	0.215	0.282
		Pt	0.028	0.043	0.061	0.084	0.110	0.139	0.172	0.248	0.337	0.441
		Throw*	5-6-9	6-7-10	6-8-11	7-8-12	7-9-12	8-9-13	8-10-14	9-11-15	9-12-16	10-12-18
24" x 24"	8 Ak = 0.307	CFM	315	395	470	550	630	705	785	940	1100	1255
		Ps	0.022	0.035	0.049	0.067	0.088	0.111	0.137	0.197	0.270	0.351
		Pt	0.032	0.050	0.072	0.098	0.128	0.161	0.200	0.287	0.392	0.511
		Throw*	6-7-11	7-8-12	7-9-13	8-10-14	9-11-15	9-11-16	10-12-17	11-13-18	11-14-20	12-15-21
24" x 24"	10 Ak = 0.418	CFM	430	535	640	750	855	960	1070	1285	1495	1710
		Ps	0.032	0.049	0.071	0.097	0.126	0.159	0.198	0.285	0.386	0.505
		Pt	0.042	0.065	0.093	0.128	0.166	0.210	0.260	0.375	0.508	0.665
		Throw*	7-9-12	8-10-14	9-11-15	9-12-16	10-12-17	11-13-18	11-14-19	12-15-21	13-16-23	14-17-25
24" x 24"	12 Ak = 0.479	CFM	490	615	735	860	980	1105	1225	1475	1720	1965
		Ps	0.036	0.056	0.080	0.109	0.142	0.181	0.222	0.322	0.438	0.571
		Pt	0.046	0.072	0.102	0.140	0.182	0.231	0.284	0.412	0.560	0.731
		Throw*	7-9-13	9-10-15	9-11-16	10-12-17	11-13-19	11-14-20	12-15-21	13-16-23	14-17-25	15-19-26
24" x 24"	14 Ak = 0.479	CFM	490	615	735	860	980	1105	1225	1475	1720	1965
		Ps	0.036	0.056	0.080	0.109	0.142	0.181	0.222	0.322	0.438	0.571
		Pt	0.046	0.072	0.102	0.140	0.182	0.231	0.284	0.412	0.560	0.731
		Throw*	7-9-13	9-10-15	9-11-16	10-12-17	11-13-19	11-14-20	12-15-21	13-16-23	14-17-25	15-19-26
24" x 24"	15 Ak = 0.479	CFM	490	615	735	860	980	1105	1225	1475	1720	1965
		Ps	0.036	0.056	0.080	0.109	0.142	0.181	0.222	0.322	0.438	0.571
		Pt	0.046	0.072	0.102	0.140	0.182	0.231	0.284	0.412	0.560	0.731
		Throw*	7-9-13	9-10-15	9-11-16	10-12-17	11-13-19	11-14-20	12-15-21	13-16-23	14-17-25	15-19-26
24" x 24"	15 Ak = 0.479	CFM	490	615	735	860	980	1105	1225	1475	1720	1965
		Ps	0.036	0.056	0.080	0.109	0.142	0.181	0.222	0.322	0.438	0.571
		Pt	0.046	0.072	0.102	0.140	0.182	0.231	0.284	0.412	0.560	0.731
		Throw*	7-9-13	9-10-15	9-11-16	10-12-17	11-13-19	11-14-20	12-15-21	13-16-23	14-17-25	15-19-26
24" x 24"	15 Ak = 0.479	CFM	490	615	735	860	980	1105	1225	1475	1720	1965
		Ps	0.036	0.056	0.080	0.109	0.142	0.181	0.222	0.322	0.438	0.571
		Pt	0.046	0.072	0.102	0.140	0.182	0.231	0.284	0.412	0.560	0.731
		Throw*	7-9-13	9-10-15	9-11-16	10-12-17	11-13-19	11-14-20	12-15-21	13-16-23	14-17-25	15-19-26
24" x 24"	15 Ak = 0.479	CFM	490	615	735	860	980	1105	1225	1475	1720	1965
		Ps	0.036	0.056	0.080	0.109	0.142	0.181	0.222	0.322	0.438	0.571
		Pt	0.046	0.072	0.102	0.140	0.182	0.231	0.284	0.412	0.560	0.731
		Throw*	7-9-13	9-10-15	9-11-16	10-12-17	11-13-19	11-14-20	12-15-21	13-16-23	14-17-25	15-19-26
24" x 24"	15 Ak = 0.479	CFM	490	615	735	860	980	1105	1225	1475	1720	1965
		Ps	0.036	0.056	0.080	0.109	0.142	0.181	0.222	0.322	0.438	0.571
		Pt	0.046	0.072	0.102	0.140	0.182	0.231	0.284	0.412	0.560	0.731
		Throw*	7-9-13	9-10-15	9-11-16	10-12-17	11-13-19	11-14-20	12-15-21	13-16-23	14-17-25	15-19-26
24" x 24"	15 Ak = 0.479	CFM	490	615	735	860	980	1105	1225	1475	1720	1965
		Ps	0.036	0.056	0.080	0.109	0.142	0.181	0.222	0.322	0.438	0.571
		Pt	0.046	0.072	0.102	0.140	0.182	0.231	0.284	0.412	0.560	0.731
		Throw*	7-9-13	9-10-15	9-11-16	10-12-17	11-13-19	11-14-20	12-15-21	13-16-23	14-17-25	15-19-26
24" x 24"	15 Ak = 0.479	CFM	490	615	735	860	980	1105	1225	1475	1720	1965
		Ps	0.036	0.056	0.080	0.109	0.142	0.181	0.222	0.322	0.438	0.571
		Pt	0.046	0.072	0.102	0.140	0.182	0.231	0.284	0.412	0.560	0.731
		Throw*	7-9-13	9-10-15	9-11-16	10-12-17	11-13-19	11-14-20	12-15-21	13-16-23	14-17-25	15-19-26
24" x 24"	15 Ak = 0.479	CFM	490	615	735	860	980	1105	1225	1475	1720	1965
		Ps	0.036	0.056	0.080	0.109	0.142	0.181	0.222	0.322	0.438	0.571
		Pt	0.046	0.072	0.102	0.140	0.182	0.231	0.284	0.412	0.560	0.731
		Throw*	7-9-13	9-10-15	9-11-16	10-12-17	11-13-19	11-14-20	12-15-21	13-16-23	14-17-25	15-19-26
24" x 24"	15 Ak = 0.479	CFM	490	615	735	860	980	1105	1225	1475	1720	1965
		Ps	0.036	0.056	0.080	0.109	0.142	0.181	0.222	0.322	0.438	0.571
		Pt	0.046	0.072	0.102	0.140	0.182	0.231	0.284	0.412	0.560	0.731
		Throw*	7-9-13	9-10-15	9-11-16	10-12-17	11-13-19	11-14-20	12-15-21	13-16-23	14-17-25	15-19-26
24" x 24"	15 Ak = 0.479	CFM	490	615	735	860	980	1105	1225	1475	1720	1965
		Ps	0.036	0.056	0.080	0.109	0.142	0.181	0.222	0.322	0.438	0.571
		Pt	0.046	0.072	0.102	0.140	0.182	0.231	0.284	0.412	0.560	0.731
		Throw*	7-9-13	9-10-15	9-11-16	10-12-17	11-13-19	11-14-20	12-15-21	13-16-23	14-17-25	15-19-26
24" x 24"	15 Ak = 0.479	CFM	490	615	735	860	980	1105	1225	1475	1720	1965
		Ps	0.036	0.056	0.080	0.109	0.142	0.181	0.222	0.322	0.438	0.571
		Pt	0.046	0.072	0.102	0.140	0.182	0.231	0.284	0.412	0.560	0.731
		Throw*	7-9-13	9-10-15	9-11-16	10-12-17	11-13-19	11-14-20	12-15-21	13-16-23	14-17-25	15-19-26
24" x 24"	15 Ak = 0.479	CFM	490	615	735	860	980	1105	1225	1475	1720	1965
		Ps	0.036	0.056	0.080	0.109	0.142	0.181	0.222	0.322	0.438	0.571
		Pt	0.046	0.072	0.102	0.140	0.182	0.231	0.284	0.412	0.560	0.731
		Throw*	7-9-13	9-10-15	9-11-16	10-12-17	11-13-19	11-14-20	12-15-21	13-16-23	14-17-25	15-19-26
24" x 24"	15 Ak = 0.479	CFM	490	615	735	860	980	1105	1225	1475	1720	1965
		Ps	0.036	0.056	0.080	0.109	0.142	0.181	0.222	0.322	0.438	0.571
		Pt	0.046	0.072	0.102	0.140	0.182	0.231	0.284	0.412	0.560	0.731
		Throw*	7-9-13	9-10-15	9-11-16	10-12-17	11-13-19	11-14-20	12-15-21	13-16-23	14-17-25	15-19-26
24" x 24"	15 Ak = 0.479	CFM	490	615	735							



## Series 5800 - Specifications

- 5800-1 - Surface Mounted
- 5800-6 - T-bar Lay-in
- 5800-7 - Concealed Spline
- 5800-9 - Donn Finline Lay-in

Air Outlets shall be model:

### **Non-Adjustable, Horizontal Discharge Pattern**

5800 manufactured by METALAIRE. Units shall be constructed of steel.  
 5800 AS manufactured by METALAIRE. Units shall be constructed of aluminized steel.  
 5800 AL manufactured by METALAIRE. Units shall be constructed of aluminum.

### **Adjustable Discharge Pattern**

5800A manufactured by METALAIRE. Units shall be constructed of steel.  
 5800A AS manufactured by METALAIRE. Units shall be constructed of aluminized steel.  
 5800A AL manufactured by METALAIRE. Units shall be constructed of aluminum.

Units shall be square with a formed backpan and three inner cones. Outlet shall have the same appearance from the face regardless of inlet size. The units shall be the size and quantity as outline in the plans and specifications.

### **Optional for Adjustable Pattern**

Inlets shall be drawn into the backpan of the diffuser. Welded inlets are not acceptable. Diffusers shall include seismic tabs drawn into the backpan.

The bottom cone shall have a removable plug in the center to allow access to adjust an optional damper.

Units shall be designed to integrate into the specified ceiling system.

Outlet shall include adjustable deflector blades located within the cones of the device. Deflectors shall allow the discharge air to be adjusted to obtain a vertical or horizontal air pattern.

### **Optional Dampers and Accessories**

#### **Butterfly Damper**

METALAIRE model BDS aluminum round butterfly type dampers shall be provided. Damper shall consist of two butterfly style blades that can be adjusted from full open to full closed. Damper shall be adjusted with a screw driver slot that can be assessed through the face of the diffuser.

#### **Radial Shutter Damper**

METALAIRE model RSD steel round radial shutter damper shall be provided. Damper shall consist of gang operated radial blades that slide perpendicular to air flow direction. The damper shall be adjusted from full open to full closed. Damper shall be adjusted with a screw driver slot that can be assessed through the face of the diffuser.

#### **Opposed Blade Damper**

METALAIRE model D3 aluminum or SD3 steel round opposed blade type dampers shall be provided. Damper shall consist of gang operated blades that can be adjusted from full open to full closed. Damper shall be adjusted with a screw driver slot that can be assessed through the face of the diffuser.

#### **Equalizing Grid**

METALAIRE model G3 aluminum round equalizing grid shall be provided. Equalizing grid shall consist of 1/2"x 1/2" x 1/2" aluminum cubed core mounting in an aluminum frame.

### **Paint Specification**

Process shall be anodic electrodeposition using an anodic acrylic paint. Units shall undergo pre-treatment including a pressurized spray stage using an alkaine cleaner and a de-ionized water rinse.

Film Properties shall meet or exceed the following standards:

Property	Test Method	Performance
Film thickness		.8-1.0 mils
Film Cure		320 F @ 20 min
Gloss – 60 deg.	ASTM D523-89	70-80%
Pencil Hardness	ASTM D3363-92A	HB-H
Crosshatch Adhesion	ASTM D3359-95	4B-5B
Direct Impact	ASTM D2794-93	100 in.lbs. Min
Reverse Impact	ASTM D2794-93	60 in.lbs. Min.
Salt Spray	ASTM B117-95	48-96 Hours
Humidity	ASTM D1735-92	500 Hours
Water Soak	ASTM D870-92	250 Hours

# DCD - Directional Ceiling Diffusers

## Series 5800 - Model Specification Guide

Square Face Diffusers - Round Neck - 3 Cone  
Series 5800

Model	Available Neck	Module	Available Finishes	Available Options	
5800-1 - Surface Mount - Steel 5800-1 AS - Surface Mount - Aluminized Steel 5800-1 AL - Surface Mount - Aluminum 5800A-1 - Adjustable - Surface Mount - Steel 5800A-1 AS - Adjustable - Surface Mount - Aluminized Steel 5800-6 - T-bar Lay-in - Steel 5800-6 AS - T-bar Lay-in - Aluminized Steel 5800-6 AL - T-bar Lay-in - Aluminum 5800A-6 - Adjustable T-bar Lay-in - Steel 5800A-6 AS - Adjustable T-bar Lay-in - Aluminized Steel 5700A-6 AL - Adjustable T-bar Lay-in - Aluminum	6" 8" 10" 12" 14" 15"	12" x 12" 24" x 24"	Standard	G3	Equalizing Grid
			01 - White	BDS	Butterfly Damper
			Options	RSD	Radial Shutter Damper
			03 - Black	BAF-1	1 Way Directional Baffle
			28 - Custom Color	BAF-2	2 Way Directional Baffle
				BAF-3	3 Way Directional Baffle
				D3	Round Opposed Blade Damper - Aluminum
				SD3	Round Opposed Blade Damper - Steel

Model	Available Neck	Module	Available Finishes	Available Options	
5800-7 - Concealed Spline - Steel 5800-7 AS - Concealed Spline - Aluminized Steel 5800A-7 - Adjustable - Concealed Spline - Steel 5800A-7 AS - Adjustable - Concealed Spline - Aluminized Steel	6" 8" 10" 12" 14" 15"	24" x 24"	Standard	G3	Equalizing Grid
			01 - White	BDS	Butterfly Damper
			Options	RSD	Radial Shutter Damper
			03 - Black	BAF-1	1 Way Directional Baffle
			28 - Custom Color	BAF-2	2 Way Directional Baffle
				BAF-3	3 Way Directional Baffle
				D3	Round Opposed Blade Damper - Aluminum
				SD3	Round Opposed Blade Damper - Steel

Model	Available Neck	Module	Available Finishes	Available Options	
M5800-6 - Metric T-bar Lay-in - Steel M5800-6 AS - Metric T-bar Lay-in - Aluminized Steel M5800-6 AL - Metric T-bar Lay-in - Aluminum	6" 8" 10" 12" 14" 15"	600mm x 600mm	Standard	G3	Equalizing Grid
			01 - White	BDS	Butterfly Damper
			Options	RSD	Radial Shutter Damper
			03 - Black	BAF-1	1 Way Directional Baffle
			28 - Custom Color	BAF-2	2 Way Directional Baffle
				BAF-3	3 Way Directional Baffle
				D3	Round Opposed Blade Damper - Aluminum
				SD3	Round Opposed Blade Damper - Steel



# DCD - Directional Ceiling Diffusers

8/2006

Directional Ceiling Diffusers



DCD

- ➔ Square Panel Face ➔ Series Phenomenator® ➔ Steel
- ➔ Series Phenomenator® AS ➔ Aluminized Steel

## Product Details

- ✦ The highest induction ratio of any commercial air diffuser available
- ✦ Excellent selection for providing exceptional comfort, especially in executive offices, conference rooms, and board rooms
- ✦ Can improve productivity by maintaining draft-free comfort in many applications
- ✦ Designed for applications calling for minimal temperature differences in a space
- ✦ Solves comfort problems in applications such as reception areas and entrance ways
- ✦ Diffuser can be applied in critical applications requiring minimal temperature gradients

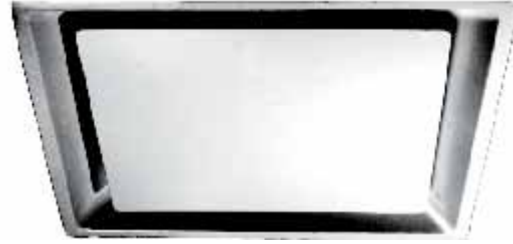

**Model Phenomenator® Shown**  
Standard Finish: 01 White

## Aluminized Steel

METALAIRES is proud to announce the availability of aluminized steel for our square Directional Ceiling Diffusers. In environments which demand aluminum's corrosion resistance, the aluminized coated steel offers the protection of aluminum and the strength of steel. The use of aluminized steel results in a product that ships better and that handle better during installation.

## What is Aluminized Steel?

Aluminized steel is continuously hot-dip coated in a bath of commercially pure aluminum to provide a metallurgical bond between the steel substrate and the aluminum coating. The aluminum bath contains 5% to 11% silicon, which is added to minimize growth of a brittle iron-aluminum inter-metallic layer and thus promote coating adherence during forming. This process melds the best features of both metallic materials; the strength and other mechanical properties of the steel substrate and the surface characteristics and corrosion resistance of the aluminum coating.

Aluminized steel has been subjected to long-term testing for resistance to atmospheric corrosion and is proven superior to any other metallic-coated steel. Over forty years of exposure tests in a mild industrial atmosphere show the coating on aluminized steel still protecting the base metal with virtually no detectable loss of the original coating.

Dimensions are in inches

### Square Face Ceiling Diffusers - Round Neck - Ultra High Performance Surface Mount

Model Phenom-1 - Steel  
Model Phenom-1 AS - Aluminized Steel

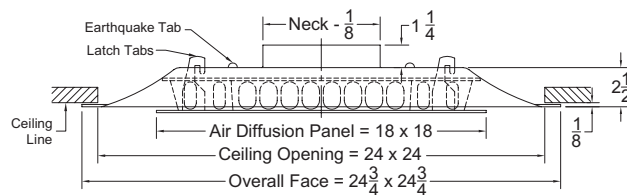

### Square Face Ceiling Diffusers - Round Neck - Ultra High Performance T-bar Lay-in

Model Phenom-6 - Steel  
Model Phenom-6 AS - Aluminized Steel

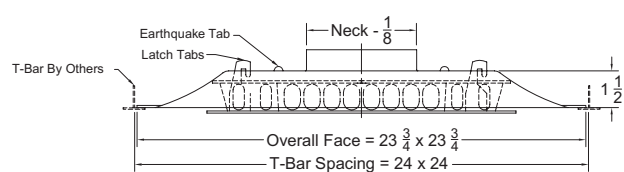

# DCD - Directional Ceiling Diffusers



## Square Face Ceiling Diffusers - Round Neck - Ultra High Performance Concealed Spline

Model Phenom-7 - Steel  
 Model Phenom-7 AS - Aluminized Steel

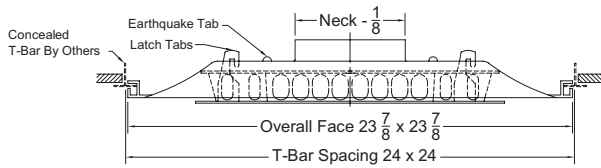

## Square Face Ceiling Diffusers - Round Neck - Ultra High Performance Donn Finline

Model Phenom-9 - Steel  
 Model Phenom-9 AS - Aluminized Steel

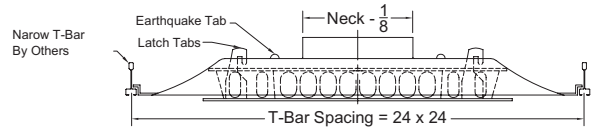

### Metric

Dimensions are in millimeters

## Square Face Ceiling Diffusers - Round Neck - Ultra High Performance T-bar Lay-in

Model Phenom-6 - Steel  
 Model Phenom-6 AS - Aluminized Steel

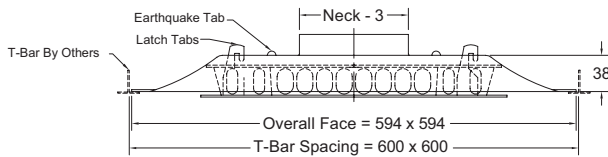

1. Available Finishes	2. Available Accessories	3. Construction Details
<p><b>Standard Finish:</b>                      01 White</p> <p><b>Optional Finish</b>                      03 Black                      28 Custom color</p>	<p>G3 - Equalizing Grid .....337                      BDS - Butterfly Damper .....335                      RSD - Radial Shutter Damper .....336                      BO - Blank off</p> <p><b>Note:</b>                      All Accessories Shipped Unattached</p>	<ul style="list-style-type: none"> <li>Sizes only as listed</li> <li>Available Neck Sizes:                          6", 8", 10", 12", 14", and 15"</li> </ul>

## Series Phenomenator® - Performance

Model Phenom (-1, -6, -7, -9), Phenom AS (-1, -6, -7, -9)

Nominal Neck Size	Neck Velocity, fpm Velocity Pressure	400 0.010	500 0.016	600 0.022	700 0.031	800 0.040	900 0.050	1000 0.062	1200 0.090
6"	Volumetric Flow Rate, CFM			120	135	155	175	195	215
	Static Pressure, Ps (in. w.c.)			0.020	0.026	0.034	0.044	0.054	0.066
	Total Pressure, Ps (in. w.c.)			0.042	0.057	0.074	0.094	0.116	0.141
	Isothermal Throw			1-1-2	1-2-3	2-2-4	2-3-5	3-4-6	3-5-7
	Non-Isothermal Throw*			1-1-1	1-1-2	1-1-3	1-2-4	2-3-5	3-4-6
Noise Criteria, NC			<20	20	21	24	26	29	
8"	Volumetric Flow Rate, CFM	140	175	210	245	280	315	350	385
	Static Pressure, Ps (in. w.c.)	0.020	0.031	0.045	0.061	0.080	0.101	0.125	0.152
	Total Pressure, Ps (in. w.c.)	0.030	0.047	0.067	0.092	0.114	0.151	0.187	0.218
	Isothermal Throw	1-2-3	2-3-5	2-5-6	3-6-7	4-6-8	5-7-10	6-8-12	7-9-13
	Non-Isothermal Throw*	1-1-2	1-2-4	1-4-5	2-5-6	3-5-7	4-6-9	5-7-10	6-7-11
Noise Criteria, NC	<20	21	25	29	32	35	37	40	
10"	Volumetric Flow Rate, CFM	220	275	325	380	435	490	545	600
	Static Pressure, Ps (in. w.c.)	0.036	0.080	0.090	0.108	0.142	0.180	0.223	0.270
	Total Pressure, Ps (in. w.c.)	0.046	0.096	0.110	0.139	0.182	0.300	0.285	0.345
	Isothermal Throw	4-6-9	6-8-10	7-9-12	8-10-13	8-10-14	9-12-16	11-14-17	12-15-18
	Non-Isothermal Throw*	3-5-7	5-7-9	5-8-11	6-9-12	7-9-13	8-11-15	10-13-15	11-13-17
Noise Criteria, NC	20	24	27	31	35	38	41	44	
12"	Volumetric Flow Rate, CFM	315	395	470	550	630	705	785	870
	Static Pressure, Ps (in. w.c.)	0.061	0.096	0.136	0.186	0.240	0.306	0.380	0.423
	Total Pressure, Ps (in. w.c.)	0.071	0.112	0.156	0.217	0.280	0.356	0.442	0.495
	Isothermal Throw	4-7-11	7-10-13	9-11-14	11-13-16	13-15-18	15-18-20	16-20-22	18-21-24
	Non-Isothermal Throw*	3-6-10	6-9-12	7-10-13	9-11-14	11-14-16	12-15-18	13-17-20	15-19-22
Noise Criteria, NC	22	27	32	36	40	43	46	52	
14"	Volumetric Flow Rate, CFM	430	535	640	750	860	975	1095	1220
	Static Pressure, Ps (in. w.c.)	0.089	0.138	0.166	0.271	0.284	0.293	0.306	0.336
	Total Pressure, Ps (in. w.c.)	0.099	0.154	0.188	0.297	0.318	0.343	0.360	0.441
	Isothermal Throw	9-10-13	11-14-15	13-15-18	14-17-21	16-19-23	17-21-25	19-23-27	23-26-29
	Non-Isothermal Throw*	6-7-11	7-11-13	11-14-15	12-15-17	16-18-20	18-20-22	20-22-24	21-23-26
Noise Criteria, NC	30	35	40	44	50	56	62	68	
15"	Volumetric Flow Rate, CFM	490	615	735	875	1020	1165		
	Static Pressure, Ps (in. w.c.)	0.112	0.177	0.253	0.337	0.355	0.364		
	Total Pressure, Ps (in. w.c.)	0.122	0.193	0.275	0.368	0.395	0.414		
	Isothermal Throw	10-12-14	13-15-17	13-16-20	16-19-22	19-21-25	21-23-27		
	Non-Isothermal Throw*	8-10-12	10-12-14	11-14-17	12-16-19	15-19-22	17-21-23		
Noise Criteria, NC	33	39	44	50	56	62			

### Series Phenom - Performance Notes:

All data are tested in accordance with ANSI/ASHRAE 70-1991

1. All pressures are in inches of water.
2. Isothermal throw values are given for velocities of 150, 100 and 50 feet per minute (room and supply air temperature are within 2°)
3. Throw\* values are given for velocities of 150, 100 and 50 feet per minute with supply air 15°F cooler than room air temperature.
4. Data were collected in accordance to ASHRAE Standard 70-1991 "Method of Testing for Rating of Air Outlets and Inlets."
5. Each NC value represents the noise criteria curve for the octave bands, with a room absorption of 10 dB, re 10<sup>-12</sup> Watts.
6. Actual throw and noise performance may vary from cataloged values with the field use of flexible duct inlets.

## Series Phenomenator® - Specifications

- Phenom-1 - Surface Mount
- Phenom-6 - T-bar Lay-in
- Phenom-7 - Concealed Spline
- Phenom-9 - Donn Finline Lay-in

### Air Outlets shall be model:

- Phenom manufactured by METALAIRES. Units shall be constructed of steel.
- Phenom AS manufactured by METALAIRES. Units shall be constructed of aluminized steel.

Units shall be square with a formed backpan, flat panel face, and a high induction inner high induction core assembly. The face panel of the outlet shall project no more than 1/4" below the ceiling grid. The units shall be the size and quantity as outline in the plans and specifications.

Inlets shall be drawn into the backpan of the diffuser. Welded inlets are not acceptable. Diffusers shall include seismic tabs drawn into the backpan. Face panel shall be held in place with hooks are secured through the backpan and be removable without the aid of tools. Units with face panels held in place with springs or clips are not acceptable.

Inner core assembly shall be steel and include a gasket between the core and the backpan. The high induction core assembly shall produce a four way discharge pattern through a series of nozzles to maximize induction and comfort. ADPI for the diffuser shall be a minimum of 97 in typical applications.

Units shall be designed to integrate into the specified ceiling system.

# DCD - Directional Ceiling Diffusers

## Optional Dampers and Accessories

### Butterfly Damper

METALAIRE model BDS aluminum round butterfly type dampers shall be provided. Damper shall consist of two butterfly style blades that can be adjusted from full open to full closed. Damper shall be adjusted with a screw driver slot.

### Radial Shutter Damper

METALAIRE model RSD steel round radial shutter damper shall be provided. Damper shall consist of gang operated radial blades that slide perpendicular to air flow direction. The damper shall be adjusted from full open to full closed. Damper shall be adjusted with a screw driver slot.

### Opposed Blade Damper

METALAIRE model D3 aluminum or SD3 steel round opposed blade type dampers shall be provided. Damper shall consist of gang operated blades that can be adjusted from full open to full closed. Damper shall be adjusted with a screw driver slot.

### Equalizing Grid

METALAIRE model G3 aluminum round equalizing grid shall be provided. Equalizing grid shall consist of 1/2" x 1/2" x 1/2" aluminum cubed core mounting in an aluminum frame.

## Performance Specification

The manufacturer shall provide published performance data. Data shall be tested in accordance to ANSI/ASHRAE Standard 70-1991.

## Paint Specification

Process shall be anodic electrodeposition using an anodic acrylic paint. Units shall undergo pre-treatment including a pressurized spray stage using an alkaine cleaner and a de-ionized water rinse.

## Series Phenomenator® - Model Specification Guide

### Square Face - Round Neck - Ultra High Performance Series Phenomenator®

Model	Available Neck	Module	Available Finishes	Available Options	
Phenom-1 - Surface Mount - Steel Phenom-1 AS - Surface Mount - Aluminized Steel Phenom-6 - T-bar Lay-in - Steel Phenom-6 AS - T-bar Lay-in - Aluminized Steel	6" 8" 10" 12" 14" 15"	24" x 24"	Standard	G3	Equalizing Grid
			01 - White	BDS	Butterfly Damper
			Options	RSD	Radial Shutter Damper
			03 - Black	BAF-1	1 Way Directional Baffle
			28 - Custom Color	BAF-2	2 Way Directional Baffle
				BAF-3	3 Way Directional Baffle
				D3	Round Opposed Blade Damper - Aluminum
				SD3	Round Opposed Blade Damper - Steel

Model	Available Neck	Module	Available Finishes	Available Options	
Phenom-7 - Concealed T-bar - Steel Phenom-7 AS - Concealed T-bar - Aluminized Steel Phenom-9 - Donn Finline - Steel Phenom-9 AS - Donn Finline - Steel	6" 8" 10" 12" 14" 15"	24" x 24"	Standard	G3	Equalizing Grid
			01 - White	BDS	Butterfly Damper
			Options	RSD	Radial Shutter Damper
			03 - Black	BAF-1	1 Way Directional Baffle
			28 - Custom Color	BAF-2	2 Way Directional Baffle
				BAF-3	3 Way Directional Baffle
				D3	Round Opposed Blade Damper - Aluminum
				SD3	Round Opposed Blade Damper - Steel

Model	Available Neck	Module	Available Finishes	Available Options	
MPhenom-6 - Metric T-bar Lay-in - Steel MPhenom-6 AS - Metric T-bar Lay-in - Aluminized Steel	6" 8" 10" 12" 14" 15"	600mm x 600mm	Standard	G3	Equalizing Grid
			01 - White	BDS	Butterfly Damper
			Options	RSD	Radial Shutter Damper
			03 - Black	BAF-1	1 Way Directional Baffle
			28 - Custom Color	BAF-2	2 Way Directional Baffle
				BAF-3	3 Way Directional Baffle
				BO	Blank Off
				D3	Round Opposed Blade Damper - Aluminum
	SD3	Round Opposed Blade Damper - Steel			



# DCD - Directional Ceiling Diffusers

8/2006

## Concentric Supply/Return Diffusers Series 5500 DAF-CC5

Directional Ceiling Diffusers



DCD

### Product Details

- ★ 5500 DAF-CC5 concentric supply/return diffuser is designed for high capacity application
- ★ Cube core return
- ★ 4-way air patterns only
- ★ Choice of 6 mounting frames
- ★ Snap-in/out core - simplifies installation
- ★ Sizes to handle full range of standard tonnage roof-top units
- ★ Supply/Return plenums are by others

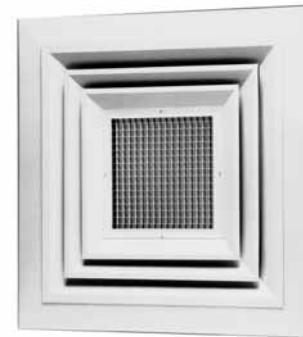

**Model 5500 DAF-CC5 Shown**  
Standard Finish: 01 White

Dimensions are in inches

### Concentric Supply/Return Ceiling Diffuser - Louvered Face - Cube Core

- Model 5500 DAF-CC5-1 - Surface Mount
- Model 5500 DAF-CC5-2 - V-Beveled
- Model 5500 DAF-CC5-6 - T-bar Lay-in
- Model 5500 DAF-CC5-7 - Concealed Spline
- Model 5500 DAF-CC5-8 - Tegular T-bar

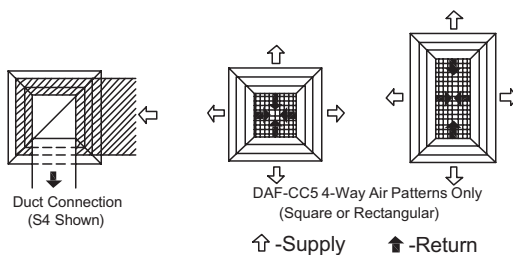
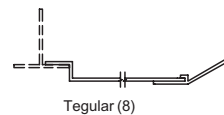
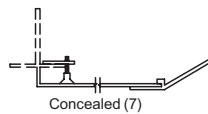
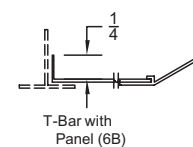
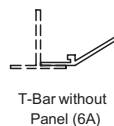
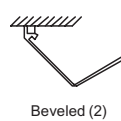
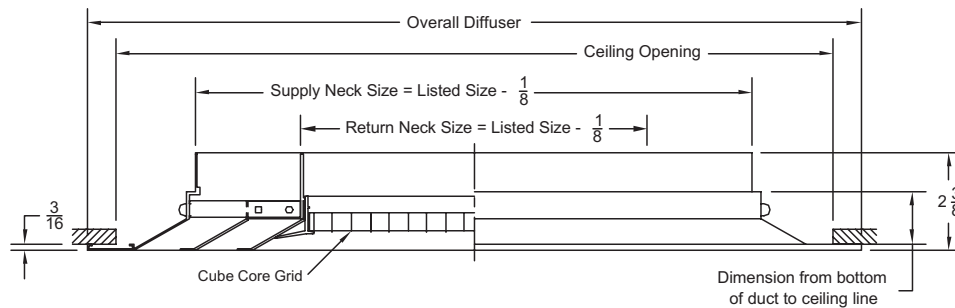

Frame Style	Overall Diffuser Size	Ceiling Opening Dimensions	Bottom of Duct To Ceiling Line
1	Supply Neck + 5 3/4	Supply Neck + 3 3/4	1 1/2
2	Supply Neck + 5 1/8	Supply Neck + 1	13/16
6A	Supply Neck + 5 3/4	T-Bar Module Size	1 11/16
6B	T-Bar Spacing - 1/4	T-Bar Module Size	1 11/16
7	T-Bar Spacing - 1/16	T-Bar Module Size	1 11/16
8	T-Bar Spacing - 1/4	T-Bar Module Size	1 15/16



# DCD - Directional Ceiling Diffusers



## 1. Available Finishes

Standard Finish:  
01 White  
Optional Finish  
02 Aluminum paint  
03 Black  
24 Mill finish  
28 Custom color

Note:  
Anodized Finish not available

## Series 5500 DAF-CC5 - Performance/(S4) 4-Way Square Pattern

Model 5500 DAF-CC5 (-1, -2, -6, -7, -8)

BASED ON 100% RETURN OF SUPPLY AIR FOR 2 - 10 TON ROOF TOP PACKAGES							
TONNAGE	2	2 1/2	3	4	5	7 1/2	10
CAPACITY (CFM)	800	1000	1200	1600	2000	3000	4000
SUPPLY NECK SIZE	21 x 21	21 x 21	24 x 24	27 x 27	30 x 30	39 x 39	45 x 45
Ak	.60	.60	.70	1.10	1.30	2.20	2.60
Vk	1335	1665	1715	1430	1575	1365	1540
Ps	.09	.15	.15	.11	.13	.10	.12
Pt	.11	.18	.18	.13	.15	.12	.15
THROW	7-14	8-16	9-17	10-20	12-23	16-31	21-39
RETURN NECK SIZE	15 x 15	15 x 15	18 x 18	18 x 18	21 x 21	27 x 27	33 x 33
Ak	1.56	1.56	2.25	2.25	3.06	5.06	7.56
INLET VELOCITY	513	640	535	710	654	590	529
Ps	.04	.06	.04	.07	.06	.05	.04
NC	25	35	37	30	37	37	38

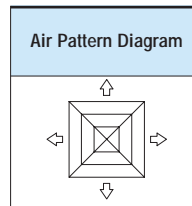

## Series 5500 DAF-CC5 - Performance/(R4) 4-Way Rectangle Pattern

Model 5500 DAF-CC5 (-1, -2, -6, -7, -8)

BASED ON 100% RETURN OF SUPPLY AIR FOR 2 - 10 TON ROOF TOP PACKAGES														
TONNAGE	2		2 1/2		3		4		5		7 1/2		10	
SIDE DESIGNATION	A	B	A	B	A	B	A	B	A	B	A	B	A	B
CAPACITY (CFM)	800		1000		1200		1600		2000		3000		4000	
SUPPLY NECK SIZE	24 x 18		27 x 18		27 x 21		36 x 21		36 x 27		45 x 36		54 x 36	
Ak	.60		.65		.70		1.20		1.35		2.30		2.60	
Vk	1335		1540		1715		1335		1480		1300		1540	
Ps	.09		.12		.15		.09		.12		.09		.12	
Pt	.11		.15		.18		.11		.14		.11		.15	
THROW	6-11	8-14	7-12	11-15	8-13	10-16	10-15	12-18	12-14	14-21	15-22	17-25	16-24	19-31
RETURN NECK SIZE	15 x 15		15 x 15		18 x 18		18 x 18		21 x 21		27 x 27		33 x 33	
Ak	1.50		1.75		2.18		2.25		3.38		5.50		7.00	
INLET VELOCITY	533		570		550		710		590		545		570	
Ps	.04		.05		.04		.07		.05		.04		.05	
NC	25		35		37		30		37		32		38	

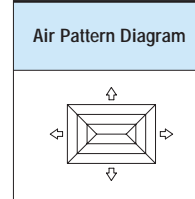

See Page DCD-92 for Series 5500 DAF-CCF Performance Notes

# DCD - Directional Ceiling Diffusers

8/2006

## Series 5500 DAF-CC5 - Performance/(S4) 4-Way Square Pattern

Model 5500 DAF-CC5 (-1, -2, -6, -7, -8)

Directional Ceiling Diffusers



DCD

		BASED ON 75% RETURN OF SUPPLY AIR						
		NECK VELOCITY						
		200	300	400	500	600	700	800
ALL SUPPLIES	FACE VELOCITY	500	750	1000	1250	1500	1750	2000
	Ps	.013	.03	.05	.08	.12	.16	.21
	Pt	.016	.04	.06	.10	.14	.19	.25
12" x 12" SUPPLY Ak = .18	TOTAL CFM THROW	90 2-4	130 3-5	175 5-8	220 6-10	265 6-12	310 7-13	350 8-14
9" x 9" RETURN Ak = .56	TOTAL CFM	70	100	130	165	200	230	260
	INLET VELOCITY	125	180	230	295	355	410	465
	Ps	.01	.01	.01	.01	.02	.03	.04
	NC	-	-	21	26	31	35	39
15" x 15" SUPPLY Ak = .40	TOTAL CFM THROW	200 3-5	300 5-8	400 6-10	500 6-12	600 7-14	700 8-17	800 10-19
9" x 9" RETURN Ak = .56	TOTAL CFM	150	225	300	375	450	525	600
	INLET VELOCITY	265	400	535	670	805	935	1070
	Ps	.01	.02	.04	.06	.09	.12	.16
	NC	-	-	21	26	35	40	45
18" x 18" SUPPLY Ak = .50	TOTAL CFM THROW	250 3-5	375 4-8	500 6-11	625 6-12	750 8-14	875 9-16	1000 10-19
12" x 12" RETURN Ak = 1.00	TOTAL CFM	190	280	375	470	560	655	750
	INLET VELOCITY	190	280	375	470	560	655	750
	Ps	.01	.01	.02	.03	.04	.06	.08
	NC	-	-	24	29	34	38	42
18" x 18" SUPPLY Ak = .28	TOTAL CFM THROW	140 4-6	210 5-8	280 6-12	350 7-13	420 8-15	490 9-17	560 11-20
15" x 15" RETURN Ak = 1.56	TOTAL CFM	105	155	210	260	315	365	420
	INLET VELOCITY	70	100	135	165	200	235	270
	Ps	.001	.002	.003	.005	.007	.009	.01
	NC	-	-	20	25	30	35	40
21" x 21" SUPPLY Ak = .60	TOTAL CFM THROW	300 3-5	450 4-8	600 5-12	750 7-13	900 8-15	1050 9-17	1200 11-20
15" x 15" RETURN Ak = 1.56	TOTAL CFM	225	340	450	560	675	790	900
	INLET VELOCITY	145	220	290	360	430	505	575
	Ps	.01	.01	.01	.02	.03	.04	.05
	NC	-	-	25	30	35	39	43
24" x 24" SUPPLY Ak = .70	TOTAL CFM THROW	350 3-5	525 4-8	700 5-11	875 6-13	1050 8-16	1225 10-20	1400 13-25
18" x 18" RETURN Ak = 2.25	TOTAL CFM	260	395	525	655	790	920	1050
	INLET VELOCITY	115	175	235	290	350	410	465
	Ps	.01	.01	.01	.01	.02	.03	.04
	NC	-	-	26	31	36	40	43
27" x 27" SUPPLY Ak = 1.10	TOTAL CFM THROW	560 3-5	845 5-10	1125 7-15	1405 8-17	1685 10-20	1965 12-24	2250 14-28
18" x 18" RETURN Ak = 2.25	TOTAL CFM	405	610	815	1015	1220	1425	1630
	INLET VELOCITY	180	270	360	450	540	635	725
	Ps	.01	.01	.02	.03	.04	.06	.07
	NC	-	-	26	32	37	41	44

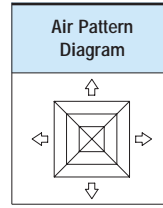

See Page DCD-92 for Series 5500 DAF-CCF Performance Notes

# DCD - Directional Ceiling Diffusers

## Series 5500 DAF-CC5 - Performance/(S4) 4-Way Square Pattern

Model 5500 DAF-CC5 (-1, -2, -6, -7, -8)

		BASED ON 75% RETURN OF SUPPLY AIR						
		NECK VELOCITY						
		200	300	400	500	600	700	800
ALL SUPPLIES	FACE VELOCITY	500	750	1000	1250	1500	1750	2000
	Ps	.013	.03	.05	.08	.12	.16	.21
	Pt	.016	.04	.06	.10	.14	.19	.25
30" x 30" SUPPLY Ak = 1.30	TOTAL CFM THROW	640 3-7	955 5-12	1275 7-16	1595 9-17	1915 11-21	2235 13-25	2550 15-30
21" x 21" RETURN Ak = 3.06	TOTAL CFM INLET VELOCITY	480 155	715 235	955 310	1195 390	1435 470	1675 545	1910 625
	Ps	.01	.01	.01	.02	.03	.04	.05
	NC	-	20	27	33	38	42	45
33" x 33" SUPPLY Ak = 1.80	TOTAL CFM THROW	900 4-8	1350 6-13	1800 8-17	2250 11-23	2700 15-30	3150 17-33	3600 19-38
21" x 21" RETURN Ak = 3.06	TOTAL CFM INLET VELOCITY	675 220	1010 330	1350 440	1690 550	2025 660	2360 770	2700 880
	Ps	.01	.02	.03	.04	.06	.08	.11
	NC	-	20	28	34	39	43	46
36" x 36" SUPPLY Ak = 2.00	TOTAL CFM THROW	1000 4-8	1500 5-13	2000 8-18	2500 12-22	3000 15-30	3500 17-34	4000 21-38
24" x 24" RETURN Ak = 4.00	TOTAL CFM INLET VELOCITY	750 185	1125 280	1500 375	1875 470	2250 560	2625 655	3000 750
	Ps	.01	.01	.02	.03	.05	.06	.08
	NC	-	20	28	34	39	43	47
39" x 39" SUPPLY Ak = 2.20	TOTAL CFM THROW	1100 5-10	1650 8-17	2200 11-21	2750 15-23	3300 18-34	3850 25-39	4400 26-42
27" x 27" RETURN Ak = 5.06	TOTAL CFM INLET VELOCITY	825 165	1240 245	1650 325	2060 410	2475 490	2890 570	3300 650
	Ps	.01	.01	.015	.02	.03	.05	.06
	NC	-	20	29	35	40	44	47
42" x 42" SUPPLY Ak = 2.90	TOTAL CFM THROW	1440 4-10	2160 10-21	2875 14-28	3595 18-34	4315 21-39	5035 25-43	5750 28-49
27" x 27" RETURN Ak = 5.06	TOTAL CFM INLET VELOCITY	1080 215	1615 320	2160 425	2695 530	3235 640	3775 745	4310 850
	Ps	.01	.01	.03	.04	.06	.08	.10
	NC	-	23	30	36	41	45	48
42" x 42" SUPPLY Ak = 2.40	TOTAL CFM THROW	1200 4-10	1800 8-17	2400 11-21	3000 15-24	3600 18-33	4200 24-38	4800 25-44
30" x 30" RETURN Ak = 6.25	TOTAL CFM INLET VELOCITY	900 145	1350 215	1800 290	2250 360	2700 430	3150 505	3600 575
	Ps	.01	.01	.01	.02	.03	.04	.05
	NC	-	-	25	33	35	40	45
42" x 42" SUPPLY Ak = 1.87	TOTAL CFM THROW	940 4-9	1410 6-13	1880 8-18	2345 12-21	2815 15-29	3285 16-33	3750 20-37
33" x 33" RETURN Ak = 7.56	TOTAL CFM INLET VELOCITY	705 95	1055 140	1410 185	1760 230	2110 280	2460 325	2815 370
	Ps	.002	.003	.005	.009	.013	.017	.022
	NC	-	20	25	33	35	40	45

		BASED ON 75% RETURN OF SUPPLY AIR						
		NECK VELOCITY						
		200	300	400	500	600	700	800
ALL SUPPLIES	FACE VELOCITY	500	750	1000	1250	1500	1750	2000
	Ps	.013	.03	.05	.08	.12	.16	.21
	Pt	.016	.04	.06	.10	.14	.19	.25
45" x 45" SUPPLY Ak = 2.60	TOTAL CFM THROW	1300 5-10	1950 9-20	2600 13-24	3250 17-28	3900 20-38	4550 27-45	5200 24-50
33" x 33" RETURN Ak = 7.56	TOTAL CFM INLET VELOCITY	975 130	1460 195	1950 255	2440 320	2925 390	3410 450	3900 515
	Ps	.003	.006	.01	.015	.02	.03	.04
	NC	-	22	28	33	39	44	48
48" x 48" SUPPLY Ak = 3.37	TOTAL CFM THROW	1690 6-11	2530 11-23	3380 16-24	4220 20-30	5065 23-41	5910 30-48	6750 35-55
33" x 33" RETURN Ak = 7.56	TOTAL CFM INLET VELOCITY	1265 170	1900 250	2530 335	3165 420	3800 500	4430 585	5065 670
	Ps	.01	.01	.02	.03	.04	.05	.06
	NC	-	23	32	37	41	45	49
60" x 60" SUPPLY Ak = 4.37	TOTAL CFM THROW	2190 7-13	3280 13-25	4375 18-28	5470 22-32	6565 25-43	7660 32-50	8750 37-56
45" x 45" RETURN Ak = 14.06	TOTAL CFM INLET VELOCITY	1640 115	2460 175	3280 235	4100 290	4925 350	5745 410	6565 465
	Ps	.002	.004	.007	.01	.02	.025	.03
	NC	-	28	32	35	38	41	46

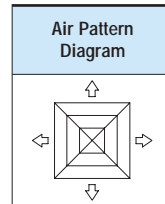

See Page DCD-92 for Series 5500 DAF-CCF Performance Notes

Directional Ceiling Diffusers



DCD

# DCD - Directional Ceiling Diffusers

8/2006

## Series 5500 DAF-CC5 - Performance/(R4) 4-Way Rectangle Pattern

Model 5500 DAF-CC5 (-1, -2, -6, -7, -8)

Directional Ceiling Diffusers



DCD

		BASED ON 75% RETURN OF SUPPLY AIR						
		NECK VELOCITY						
		200	300	400	500	600	700	800
ALL SUPPLIES	FACE VELOCITY	500	750	1000	1250	1500	1750	2000
	Ps	.013	.03	.05	.08	.12	.16	.21
	Pt	.016	.04	.06	.10	.14	.19	.25
36" x 24" SUPPLY Ak = 1.28	TOTAL CFM	640	960	1280	1600	1920	2240	2560
	THROW A SIDE	5-7	7-10	9-13	11-17	13-20	16-23	18-28
	THROW B SIDE	4-7	5-9	7-11	9-14	11-17	13-18	15-23
27" x 15" RETURN Ak = 2.80	TOTAL CFM	480	720	960	1200	1440	1680	1920
	INLET VELOCITY	170	255	340	430	515	600	685
	Ps	.01	.01	.02	.03	.04	.05	.07
	NC	20	23	26	30	35	40	45
36" x 27" SUPPLY Ak = 1.35	TOTAL CFM	675	1015	1350	1690	2030	2365	2705
	THROW A SIDE	5-8	7-10	9-13	11-17	13-20	16-24	18-28
	THROW B SIDE	4-7	6-9	8-12	10-15	11-19	14-20	17-25
27" x 18" RETURN Ak = 3.37	TOTAL CFM	505	760	1010	1270	1520	1775	2030
	INLET VELOCITY	150	225	300	375	450	525	600
	Ps	.01	.01	.01	.02	.03	.04	.05
	NC	20	23	26	30	35	40	45
36" x 30" SUPPLY Ak = 1.43	TOTAL CFM	715	1070	1430	1785	2140	2500	2855
	THROW A SIDE	5-9	7-11	9-13	11-17	13-20	16-23	18-28
	THROW B SIDE	4-7	6-9	8-12	10-15	12-18	15-21	17-25
27" x 21" RETURN Ak = 3.93	TOTAL CFM	535	800	1070	1340	1605	1875	2140
	INLET VELOCITY	135	205	270	340	410	480	545
	Ps	.01	.01	.01	.02	.025	.03	.04
	NC	20	23	26	30	35	40	45
42" x 33" SUPPLY Ak = 2.10	TOTAL CFM	1050	1575	2100	2625	3150	3675	4200
	THROW A SIDE	6-10	8-12	11-16	13-20	16-24	19-28	22-32
	THROW B SIDE	4-8	6-10	9-14	12-18	14-21	17-25	19-29
30" x 21" RETURN Ak = 4.37	TOTAL CFM	790	1180	1575	1970	2360	2755	3150
	INLET VELOCITY	180	270	360	450	540	630	720
	Ps	.01	.01	.02	.03	.04	.06	.07
	NC	20	23	26	30	35	40	45
48" x 21" SUPPLY Ak = 1.50	TOTAL CFM	750	1125	1500	1875	2250	2625	3000
	THROW A SIDE	4-8	7-11	10-15	13-19	17-23	18-26	22-31
	THROW B SIDE	3-6	6-9	7-11	9-14	11-16	13-20	15-23
39" x 12" RETURN Ak = 3.25	TOTAL CFM	560	845	1125	1405	1690	1970	2250
	INLET VELOCITY	170	260	345	430	520	605	690
	Ps	.01	.01	.02	.03	.04	.05	.07
	NC	20	23	26	30	35	40	45
48" x 24" SUPPLY Ak = 1.57	TOTAL CFM	790	1180	1575	1970	2365	2760	3150
	THROW A SIDE	5-8	7-11	10-15	13-19	15-23	18-27	21-31
	THROW B SIDE	4-7	6-9	8-11	9-14	11-17	13-20	15-23
39" x 15" RETURN Ak = 4.06	TOTAL CFM	590	885	1180	1480	1775	2070	2360
	INLET VELOCITY	145	220	290	365	440	510	580
	Ps	.01	.01	.01	.02	.03	.04	.05
	NC	20	23	26	30	35	40	45
48" x 27" SUPPLY Ak = 1.65	TOTAL CFM	825	1240	1650	2065	2480	2890	3305
	THROW A SIDE	6-8	8-12	10-15	13-19	15-23	18-27	21-30
	THROW B SIDE	5-7	7-10	8-12	10-15	13-19	14-21	17-25
39" x 18" RETURN Ak = 4.87	TOTAL CFM	620	930	1240	1550	1860	2170	2480
	INLET VELOCITY	130	190	255	320	380	445	510
	Ps	.01	.01	.01	.01	.02	.03	.04
	NC	20	23	26	30	35	40	45

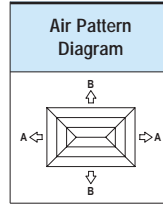

See Page DCD-92 for Series 5500 DAF-CCF Performance Notes

# DCD - Directional Ceiling Diffusers

## Series 5500 DAF-CC5 - Performance/(R4) 4-Way Rectangle Pattern

Model 5500 DAF-CC5 (-1, -2, -6, -7, -8)

		BASED ON 75% RETURN OF SUPPLY AIR						
		NECK VELOCITY						
		200	300	400	500	600	700	800
ALL SUPPLIES	FACE VELOCITY	500	750	1000	1250	1500	1750	2000
	<i>P<sub>s</sub></i>	.013	.03	.05	.08	.12	.16	.21
	<i>P<sub>t</sub></i>	.016	.04	.06	.10	.14	.19	.25
48 x 30 SUPPLY Ak = 1.73	TOTAL CFM	865	1295	1730	2160	2590	3025	3455
	THROW A SIDE	5-9	7-11	10-15	13-19	15-23	18-27	21-31
	THROW B SIDE	4-7	6-9	8-12	11-16	13-19	15-22	17-25
39 x 21 RETURN Ak = 5.68	TOTAL CFM	650	970	1295	1620	1940	2270	2590
	INLET VELOCITY	115	170	230	285	340	400	455
	<i>P<sub>s</sub></i>	.01	.01	.01	.01	.015	.02	.03
	NC	20	23	26	30	35	40	45
48 x 33 SUPPLY Ak = 2.30	TOTAL CFM	1150	1725	2300	2875	3450	4025	4600
	THROW A SIDE	7-11	9-13	11-17	15-22	18-26	21-30	23-34
	THROW B SIDE	5-8	6-10	9-14	12-18	14-21	17-25	19-29
36 x 21 RETURN Ak = 5.25	TOTAL CFM	860	1295	1725	2155	2590	3020	3450
	INLET VELOCITY	165	250	330	410	495	575	655
	<i>P<sub>s</sub></i>	.01	.01	.015	.02	.03	.05	.06
	NC	20	23	26	30	35	40	45
48 x 36 SUPPLY Ak = 2.40	TOTAL CFM	1200	1800	2400	3000	3600	4200	4800
	THROW A SIDE	7-11	9-13	11-17	15-22	18-26	21-30	23-34
	THROW B SIDE	5-9	7-11	10-15	13-19	15-21	17-26	20-30
36 x 24 RETURN Ak = 6.00	TOTAL CFM	900	1350	1800	2250	2700	3150	3600
	INLET VELOCITY	150	225	300	375	450	525	600
	<i>P<sub>s</sub></i>	.01	.01	.01	.02	.03	.04	.05
	NC	20	23	26	30	35	40	45
48 x 39 SUPPLY Ak = 2.50	TOTAL CFM	1250	1875	2500	3125	3750	4375	5000
	THROW A SIDE	7-11	9-13	11-17	15-22	16-25	18-27	21-31
	THROW B SIDE	5-9	7-11	10-15	11-16	13-19	15-23	18-28
36 x 37 RETURN Ak = 6.75	TOTAL CFM	940	1405	1875	2345	2810	3280	3750
	INLET VELOCITY	140	210	280	350	415	485	555
	<i>P<sub>s</sub></i>	.01	.01	.01	.02	.025	.03	.04
	NC	20	23	26	30	35	40	45
48 x 45 SUPPLY Ak = 3.25	TOTAL CFM	1625	2440	3250	4065	4880	5690	6500
	THROW A SIDE	8-13	10-15	13-19	16-24	19-29	23-33	26-38
	THROW B SIDE	7-12	9-14	12-18	15-23	18-28	21-32	24-35
33 x 30 RETURN Ak = 6.87	TOTAL CFM	1220	1830	2440	3050	3660	4270	4875
	INLET VELOCITY	180	265	355	445	535	620	710
	<i>P<sub>s</sub></i>	.01	.01	.02	.03	.04	.05	.07
	NC	20	23	26	30	35	40	45

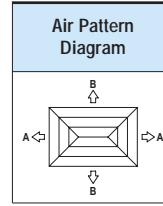

See Page DCD-92 for Series 5500 DAF-CCF Performance Notes

# DCD - Directional Ceiling Diffusers

8/2006

## Series 5500 DAF-CC5 - Performance/(R4) 4-Way Rectangle Pattern

Model 5500 DAF-CC5 (-1, -2, -6, -7, -8)

Directional Ceiling Diffusers



DCD

		BASED ON 75% RETURN OF SUPPLY AIR						
		NECK VELOCITY						
		200	300	400	500	600	700	800
ALL SUPPLIES	FACE VELOCITY	500	750	1000	1250	1500	1750	2000
	Ps	.013	.03	.05	.08	.12	.16	.21
	Pt	.016	.04	.06	.10	.14	.19	.25
60" x 21" SUPPLY Ak = 1.82	TOTAL CFM	910	1365	1820	2275	2730	3185	3640
	THROW A SIDE	6-10	9-13	11-17	17-22	18-26	21-30	23-34
	THROW B SIDE	4-7	6-9	8-11	10-15	12-18	14-20	15-23
51" x 12" RETURN Ak = 4.25	TOTAL CFM	680	1025	1365	1705	2050	2390	2730
	INLET VELOCITY	160	240	320	400	480	560	640
	Ps	.01	.01	.01	.02	.03	.05	.06
	NC	20	23	26	30	35	40	45
60" x 27" SUPPLY Ak = 1.95	TOTAL CFM	975	1465	1950	2440	2930	3415	3900
	THROW A SIDE	7-11	9-13	11-17	17-22	18-26	21-30	23-35
	THROW B SIDE	4-7	6-9	8-12	10-15	13-19	14-20	17-25
51" x 18" RETURN Ak = 6.37	TOTAL CFM	730	1110	1460	1833	2200	2560	2925
	INLET VELOCITY	115	175	230	290	345	400	460
	Ps	.01	.01	.01	.01	.02	.03	.04
	NC	20	23	26	30	35	40	45
60" x 30" SUPPLY Ak = 2.02	TOTAL CFM	1015	1520	2030	2535	3040	3550	4055
	THROW A SIDE	7-11	9-13	11-17	17-22	18-25	21-30	23-35
	THROW B SIDE	4-7	6-9	8-12	11-16	13-19	15-23	17-25
51" x 21" RETURN Ak = 7.43	TOTAL CFM	760	1140	1520	1900	2280	2660	3040
	INLET VELOCITY	100	155	205	255	310	360	410
	Ps	.01	.01	.01	.01	.02	.03	.04
	NC	20	23	26	30	35	40	45
60" x 33" SUPPLY Ak = 2.70	TOTAL CFM	1350	2025	2700	3375	4050	4725	5400
	THROW A SIDE	8-13	10-15	13-20	17-24	18-30	22-34	26-38
	THROW B SIDE	5-9	7-11	9-14	12-18	14-21	17-25	19-29
48" x 21" RETURN Ak = 7.00	TOTAL CFM	1010	1520	2025	2530	3035	3545	4050
	INLET VELOCITY	145	215	290	360	435	505	580
	Ps	.01	.01	.01	.02	.03	.04	.05
	NC	20	23	26	30	35	40	45
60" x 36" SUPPLY Ak = 2.80	TOTAL CFM	1400	2100	2800	3500	4200	4900	5600
	THROW A SIDE	8-13	10-15	13-20	17-25	18-30	23-34	27-40
	THROW B SIDE	5-9	7-11	12-15	13-19	15-22	17-26	20-30
48" x 24" RETURN Ak = 8.00	TOTAL CFM	1050	1575	2100	2625	3150	3675	4200
	INLET VELOCITY	130	195	260	330	395	460	525
	Ps	.01	.01	.01	.02	.03	.04	.05
	NC	20	23	26	30	35	40	45
60" x 39" SUPPLY Ak = 2.90	TOTAL CFM	1450	2175	2900	3625	4350	5075	5800
	THROW A SIDE	8-13	10-15	14-20	17-25	18-30	23-34	27-40
	THROW B SIDE	5-9	7-11	10-15	13-19	15-23	19-28	20-32
48" x 27" RETURN Ak = 9.00	TOTAL CFM	1090	1630	2175	2720	3260	3805	4350
	INLET VELOCITY	120	180	240	300	360	420	485
	Ps	.01	.01	.01	.02	.025	.03	.04
	NC	20	23	26	30	35	40	45
60" x 42" SUPPLY Ak = 3.62	TOTAL CFM	1810	2720	3625	4530	5435	6340	7250
	THROW A SIDE	9-15	11-17	15-23	19-29	23-35	27-40	30-45
	THROW B SIDE	7-11	9-13	11-17	15-23	19-27	22-31	24-35
45" x 27" RETURN Ak = 8.43	TOTAL CFM	1360	2040	2720	3400	4080	4755	5440
	INLET VELOCITY	160	240	320	405	485	565	645
	Ps	.01	.01	.01	.02	.03	.04	.06
	NC	20	25	30	35	40	45	50

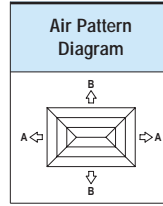

See Page DCD-92 for Series 5500 DAF-CCF Performance Notes

# DCD - Directional Ceiling Diffusers

## Series 5500 DAF-CC5 - Performance/(R4) 4-Way Rectangle Pattern

Model 5500 DAF-CC5 (-1, -2, -6, -7, -8)

		BASED ON 75% RETURN OF SUPPLY AIR						
		NECK VELOCITY						
		200	300	400	500	600	700	800
ALL SUPPLIES	FACE VELOCITY	500	750	1000	1250	1500	1750	2000
	Ps	.013	.03	.05	.08	.12	.16	.21
	Pt	.016	.04	.06	.10	.14	.19	.25
60 x 45 SUPPLY Ak = 3.75	TOTAL CFM	1875	2815	3750	4690	5630	6565	7500
	THROW A SIDE	9-15	11-17	15-23	19-28	22-34	26-40	30-45
	THROW B SIDE	7-12	9-14	12-18	15-23	17-27	21-32	24-36
45 x 30 RETURN Ak = 9.37	TOTAL CFM	1400	2110	2810	3520	4220	4925	5625
	INLET VELOCITY	150	225	300	375	450	525	600
	Ps	.01	.01	.01	.02	.03	.04	.05
	NC	20	25	30	35	40	45	50
60 x 48 SUPPLY Ak = 3.88	TOTAL CFM	1940	2910	3880	4850	5820	6790	7760
	THROW A SIDE	9-15	11-17	15-23	19-29	22-35	27-41	31-46
	THROW B SIDE	7-12	9-14	13-19	16-24	18-29	23-34	25-39
45 x 33 RETURN Ak = 10.30	TOTAL CFM	1455	2180	2910	3640	4365	5090	5820
	INLET VELOCITY	140	210	280	355	425	495	565
	Ps	.01	.01	.01	.02	.025	.03	.04
	NC	20	25	30	35	40	45	50
60 x 51 SUPPLY Ak = 4.00	TOTAL CFM	2000	3000	4000	5000	6000	7000	8000
	THROW A SIDE	9-15	11-17	15-23	19-29	22-35	27-41	31-46
	THROW B SIDE	8-13	10-15	13-20	16-25	20-30	23-35	27-40
45 x 36 RETURN Ak = 11.25	TOTAL CFM	1500	2250	3000	3750	4500	5250	6000
	INLET VELOCITY	135	200	265	335	400	465	535
	Ps	.01	.01	.01	.02	.025	.03	.04
	NC	20	25	30	35	40	45	50
60 x 54 SUPPLY Ak = 4.80	TOTAL CFM	2400	3600	4800	6000	7200	8400	9600
	THROW A SIDE	10-16	12-18	16-25	22-32	26-39	31-46	34-52
	THROW B SIDE	9-15	11-17	15-24	20-30	24-36	27-42	32-48
42 x 36 RETURN Ak = 10.50	TOTAL CFM	1800	2700	3600	4500	5400	6300	7200
	INLET VELOCITY	170	255	340	430	515	600	685
	Ps	.01	.01	.02	.03	.04	.05	.07
	NC	20	25	30	35	40	45	50
60 x 57 SUPPLY Ak = 4.95	TOTAL CFM	2480	3715	4950	6190	7430	8665	9900
	THROW A SIDE	11-17	13-19	17-26	22-33	26-39	33-49	35-52
	THROW B SIDE	10-16	12-18	16-24	21-30	25-36	30-46	32-50
42 x 39 RETURN Ak = 11.37	TOTAL CFM	1860	2790	3710	4640	5570	6500	7425
	INLET VELOCITY	165	245	325	410	490	570	655
	Ps	.01	.01	.01	.02	.03	.05	.06
	NC	20	25	30	35	40	45	50

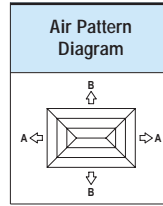

See Page DCD-92 for Series 5500 DAF-CCF Performance Notes

## Series 5500 DAF-CC5 - Performance Notes:

All data are tested in accordance with ANSI/ASHRAE 70-1991

### Definition of Units:

- CFM** - Cubic Feet per Minute (air)
- fpm** - Velocity of air stream in Feet Per Minute
- Pv** - Velocity pressure (inches of water column)
- Pt** - Total pressure (inches of water column)
- Ps** - Static pressure = Pt - Pv (inches of water column)
- Throw** - Cataloged throw is horizontal distances in feet to the terminal velocities of 150 and 50 fpm with ambient supply air temperature.
- NC** - Noise criterion, sound pressure level. NC ratings are based on sound power level (Lw) RE: 10E-12 watts minus a 10 dB room attenuation in all octave bands
- Ak** - Area Factor

## Series 5500 DAF-CC5 - Specifications



- 5500 DAF-CC5-1 - Surface Mount*
- 5500 DAF-CC5-2 - V-Beveled Drop Face*
- 5500 DAF-CC5-4 - Deep Drop Frame*
- 5500 DAF-CC5-6 - T-bar Lay-in*
- 5500 DAF-CC5-7 - Concealed Spline*
- 5500 DAF-CC5-8 - Tegular Lay-in*

Combination concentric supply/return units shall be model 5500 DAF-CC5 manufactured by METALAIRE. Units shall consist of a fixed pattern outer ring of louvers that discharge supply air. The inner return or exhaust core shall consist of aluminum 1/2" x 1/2" x 1/2" cubed core.

Units shall be designed to integrate into the specified ceiling system.

### Performance Specification

The manufacturer shall provide published performance data. Data shall be tested in accordance to ANSI/ASHRAE Standard 70-1991.

### Paint Specification

Process shall be anodic electrodeposition using an anodic acrylic paint. Units shall undergo pre-treatment including a pressurized spray stage using an alkaline cleaner and a de-ionized water rinse.

Film Properties shall meet or exceed the following standards:

Property	Test Method	Performance
Film thickness		.8-1.0 mils
Film Cure		320 F @ 20 min
Gloss – 60 deg.	ASTM D523-89	70-80%
Pencil Hardness	ASTM D3363-92A	HB-H
Crosshatch Adhesion	ASTM D3359-95	4B-5B
Direct Impact	ASTM D2794-93	100 in.lbs. Min
Reverse Impact	ASTM D2794-93	60 in.lbs. Min.
Salt Spray	ASTM B117-95	48-96 Hours
Humidity	ASTM D1735-92	500 Hours
Water Soak	ASTM D870-92	250 Hours



# DCD - Directional Ceiling Diffusers

## Series 5500 DAF-CC5 - Model Specification Guide

Conentric Supply/Return Ceiling Diffusers - Louvered Face - Cubed Core  
Series 5500 DAF-CC5 - Aluminum

Model	Supply	Return	Available Finishes
5500 DAF CC5-1 - Flush Surface Mount	12" x 12" thru 60" x 60"	9" x 9" thru 45" x 45"	Standard
5500 DAF CC5-2 - V-beveled Drop Surface Mount			01 - White
			Optional
			03 - Black
			24 - Mill
			28 - Custom Color

Model	Supply	Return	Module	Available Finishes
5500 DAF CC5-6A - Lay-in T-bar (without panel)	12" x 12" thru 42" x 42"	9" x 9" thru 33" x 33"	24" x 24" 48" x 24" 48" x 48"	Standard
5500 DAF CC5-6B - Lay-in T-bar (with panel)				01 - White
5500 DAF CC5-7 - Concealed Spline				Optional
5500 DAF CC5-8 - Tegular T-bar				03 - Black
				24 - Mill
				28 - Custom Color



# DCD - Directional Ceiling Diffusers

8/2006

Directional Ceiling Diffusers



DCD

## ➔ Square/Rectangular Modular Core ➔ Series 9000 ➔ Aluminum

### Product Details

- ✪ The 9000 is a highly flexible directional mounting applications ceiling diffuser available in a wide range of border types
- ✪ Modular cores can be adjusted to obtain 1, 2 way opposite, 2 way corner, 3 or 4 way air patterns
- ✪ Cores are easy to remove with spring loaded latches - no tools required
- ✪ Lay-in T-bar border 6 can be used in surface mounting applications by adding optional T-bar Plaster Frame (TBPf)
- ✪ The 9000 is an excellent choice for VAV applications



**Model 9000-1 Shown**  
Standard Finish: 01 White

Dimensions are in inches

### Square/Rectangular Modular Core Ceiling Diffusers Surface Mount Model 9000-1

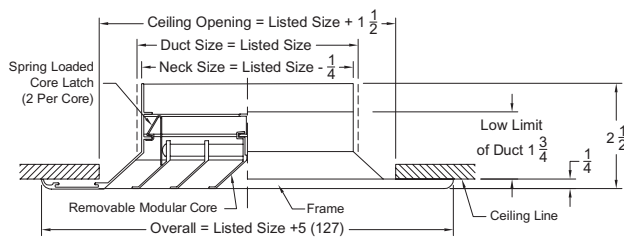

### Square/Rectangular Modular Core Ceiling Diffusers Beveled Surface Mount Model 9000-2

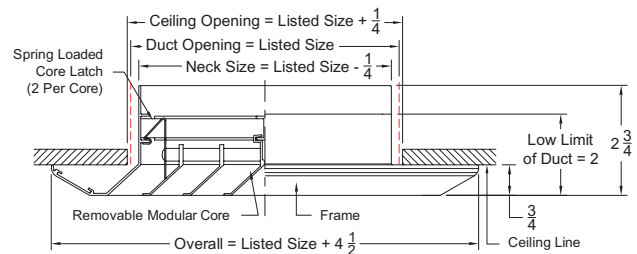

### Square/Rectangular Modular Core Ceiling Diffusers T-bar Lay-in Model 9000-6

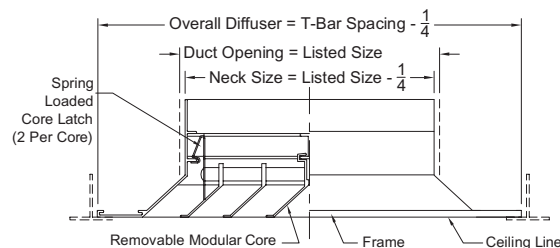

### Square/Rectangular Modular Core Ceiling Diffusers T-bar Lay-in Panel Model 9000-6P

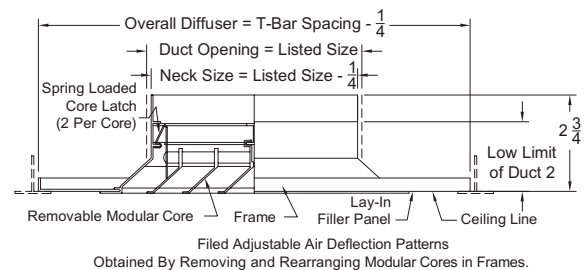

### Square/Rectangular Modular Core Ceiling Diffusers Concealed Spline Model 9000-7

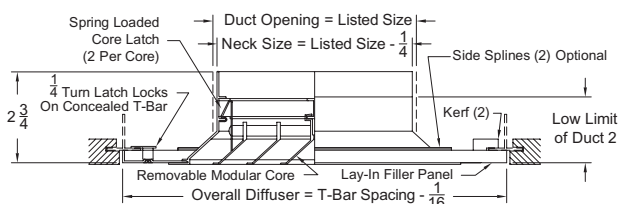

### Square/Rectangular Modular Core Ceiling Diffusers Tegular T-bar Model 9000-8

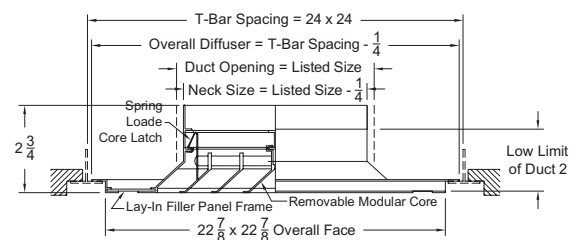

# DCD - Directional Ceiling Diffusers



**Square/Rectangular Modular Core Ceiling Diffusers**  
**Donn Finline**  
 Model 9000-9

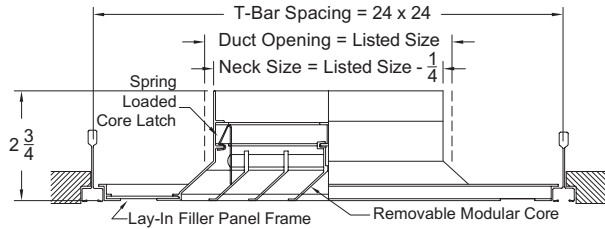

**Air Patterns - Square Face Ceiling Diffusers**

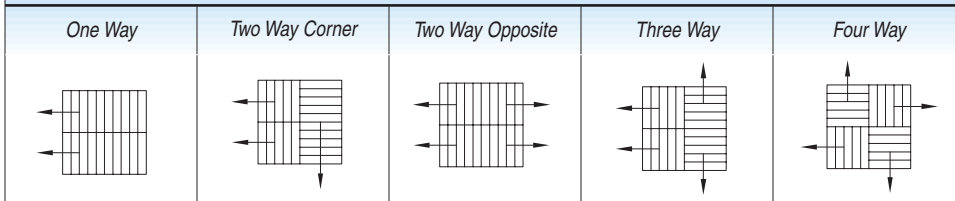

1. Available Finishes	2. Available Accessories
<p><b>Standard Finish:</b>                      01 White</p> <p><b>Optional Finish</b>                      02 Aluminum paint                      03 Black                      28 Custom color</p>	<p>(Shipped Unattached)</p> <p>OBD - Opposed Blade Damper - Steel .....334                      OBDA - Opposed Blade Damper - Aluminum .....334                      L9 - Equalizing Grid .....334                      TR Deep - Square to Round Transition - Deep .....338</p>

# DCD - Directional Ceiling Diffusers

8/2006

## Series 9000 - Performance

4 Core - Models 9000-1, 9000-2, 9000-6, 9000-6P, 9000-7, 9000-8, 9000-9

Listed Size & Neck Area Sq. Ft.	Effective Area AK Sq. Ft.	Vn Neck Velocity fpm Vk Outlet Velocity fpm Pt Total Pressure Side Designation	200		300		400		500		600		700	
			A	B	A	B	A	B	A	B	A	B	A	B
6" X 6" 0.25	0.112	CFM NC	50 <20	75 <20	100 <20	125 20	150 26	175 31						
		Throw	4-Way 3-Way 2-Way 1-Way	2-3 3-4 3-4 4-6	3-4 4-6 6-8	4-5 6-7 8-10	4-6 6-8 8-12	5-7 7-10 10-14	6-8 8-11 12-16					
8" x 8" 0.44	0.196	CFM NC	90 <20	130 <20	175 <20	220 23	265 28	310 33						
		Throw	4-Way 3-Way 2-Way 1-Way	3-4 3-4 4-6 4-6 6-8	4-5 4-5 6-7 6-7 8-10	5-7 5-7 7-10 7-10 10-14	6-8 6-8 8-11 8-11 12-16	6-9 6-9 8-13 8-13 12-18	7-10 7-10 10-14 10-14 14-20					
10" x 10" 0.69	0.312	CFM NC	140 <20	205 <20	275 <20	345 23	415 28	485 33						
		Throw	4-Way 3-Way 2-Way 1-Way	4-5 4-5 6-7 6-7 8-10	5-7 5-7 7-10 7-10 10-14	6-9 6-9 8-13 8-13 12-18	7-10 7-10 10-14 10-14 14-20	8-12 8-12 11-17 11-17 16-24	9-13 9-13 13-18 13-18 18-26					
12" x 12" 1.00	0.444	CFM NC	200 <20	300 <20	400 <20	500 25	600 31	700 36						
		Throw	4-Way 3-Way 2-Way 1-Way	4-6 4-6 6-8 6-8 8-12	6-8 6-8 8-11 8-11 12-16	7-10 7-10 10-14 10-14 14-20	8-12 8-12 11-17 11-17 16-24	9-14 9-14 13-20 13-20 18-28	10-15 10-15 14-21 14-21 20-30					
14" x 14" 1.36	0.604	CFM NC	270 <20	405 <20	545 21	680 27	815 33	950 38						
		Throw	4-Way 3-Way 2-Way 1-Way	5-7 5-7 7-10 7-10 10-14	7-10 7-10 10-14 10-14 14-20	8-12 8-12 11-17 11-17 16-24	10-14 10-14 14-20 14-20 20-28	11-17 11-17 16-24 16-24 22-34	12-18 12-18 17-25 17-25 24-36					
16" x 16" 1.78	0.792	CFM NC	355 20	530 20	710 21	885 28	1070 33	1245 38						
		Throw	4-Way 3-Way 2-Way 1-Way	5-8 5-8 7-11 7-11 10-16	8-11 8-11 11-16 11-16 16-22	9-14 9-14 13-20 13-20 18-28	11-16 11-16 16-22 16-22 22-32	12-19 12-19 17-27 17-27 24-38	13-20 13-20 18-28 18-28 26-40					
18" x 18" 2.25	0.996	CFM NC	450 <20	670 <20	900 22	1120 29	1345 34	1570 39						
		Throw	4-Way 3-Way 2-Way 1-Way	6-9 6-9 8-13 8-13 12-18	9-12 9-12 13-17 13-17 18-24	10-15 10-15 14-21 14-21 20-30	12-18 12-18 17-25 17-25 24-36	13-21 13-21 18-30 18-30 26-42	15-23 15-23 21-32 21-32 30-46					
20" x 20" 2.78	1.236	CFM NC	555 <20	830 <20	1110 23	1390 30	1670 35	1945 40						
		Throw	4-Way 3-Way 2-Way 1-Way	7-10 7-10 10-14 10-14 14-20	10-13 10-13 14-18 14-18 20-26	12-16 12-16 17-22 17-22 24-32	13-20 13-20 18-28 18-28 26-40	15-23 15-23 21-32 21-32 30-46	16-24 16-24 22-34 22-34 32-48					
22" x 22" 3.36	1.492	CFM NC	670 <20	1010 <20	1345 23	1680 31	2015 36	2350 41						
		Throw	4-Way 3-Way 2-Way 1-Way	7-11 7-11 10-16 10-16 14-22	11-15 11-15 16-21 16-21 22-30	13-18 13-18 18-25 18-25 26-36	15-22 15-22 21-31 21-31 30-44	16-25 16-25 22-35 22-35 32-50	18-27 18-27 25-38 25-38 36-54					
24" x 24" 4.00	1.776	CFM NC	800 <20	1200 <20	1600 26	2000 32	2400 38	2800 42						
		Throw	4-Way 3-Way 2-Way 1-Way	8-12 8-12 11-17 11-17 16-24	12-16 12-16 17-22 17-22 24-32	14-20 14-20 20-28 20-28 28-40	16-24 16-24 22-34 22-34 32-48	18-28 18-28 25-39 25-39 36-56	20-30 20-30 28-42 28-42 40-60					

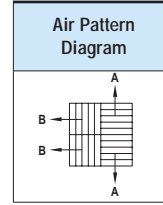

Directional Ceiling Diffusers



DCD

See Page DCD-97 for Series 9000 Performance Notes

# DCD - Directional Ceiling Diffusers

## Series 9000 - Performance

Single Core - Models 9000-1, 9000-2, 9000-6, 9000-6P, 9000-7, 9000-8, 9000-9

Single Core Size (Inches)	Single Core Area (Sq. Ft.)	Ak Effective Area (Sq. Ft.)	Neck Outlet Vel Pt.	200	300	400	500	600	700	800
				450 0.013	675 0.028	900 0.50	1125 0.079	1350 0.114	1575 0.155	1800 0.202
3" X 3"	0.063	0.028	CFM THROW NC	13	19	25	32	38	44	50
				2-3 <20	3-4 <20	4-5 <20	4-6 <20	5-7 20	6-8 25	6-9 27
4" X 4"	0.111	0.049	CFM THROW NC	22	33	44	56	67	78	89
				3-4 <20	4-5 <20	5-7 <20	6-8 <20	6-9 22	7-10 27	8-11 31
5" X 5"	0.174	0.078	CFM THROW NC	35	52	70	87	104	122	139
				4-5 <20	5-7 <20	6-9 <20	7-10 <20	8-12 22	9-13 27	10-14 31
6" X 6"	0.250	0.111	CFM THROW NC	50	75	100	125	150	175	200
				4-6 <20	6-8 <20	7-10 <20	8-12 <20	9-14 25	10-15 30	11-16 34
7" X 7"	0.340	0.151	CFM THROW NC	68	102	136	170	204	238	272
				5-7 <20	7-10 <20	8-12 <20	10-14 21	11-17 27	12-18 32	13-19 35
8" X 8"	0.445	0.198	CFM THROW NC	89	133	178	222	267	311	355
				5-8 <20	8-11 <20	9-14 <20	11-16 22	12-19 27	13-20 32	15-22 36
9" X 9"	0.562	0.249	CFM THROW NC	112	169	225	281	337	393	459
				6-9 <20	9-12 <20	10-15 <20	12-18 23	13-21 28	15-23 33	16-24 37
10" X 10"	0.695	0.309	CFM THROW NC	139	208	278	347	416	486	555
				7-10 <20	10-13 <20	12-16 <20	13-20 24	15-23 29	16-24 34	18-26 38

### Series 9000 - Performance Notes:

All data are tested in accordance with ANSI/ASHRAE 70-1991

### Definition of Units:

- CFM - Cubic Feet per Minute (air)
- fpm - Velocity of air stream in Feet Per Minute
- Pv - Velocity pressure (inches of water column)
- Pt - Total pressure (inches of water column)
- Ps - Static pressure = Pt - Pv (inches of water column)
- Throw - Cataloged throw is horizontal distances in feet to the terminal velocities of 150 and 100 fpm with supply air temperature 20° F below room air temperature
- NC - Noise criterion, sound pressure level. NC ratings are based on sound power level (Lw) RE: 10E-12 watts minus a 10 dB room attenuation in all octave bands
- Ak - Area Factor

## Series 9000 - Specification

- 9000-1 - Surface Mounted
- 9000-2 - Beveled
- 9000-6 - T-bar Lay-in
- 9000-7 - Concealed Spline
- 9000-8 - Tegular Lay-in
- 9000-9 - Donn Finline Lay-in

Air Outlets shall be model 9000 manufactured by METALAIR. Units shall consist of an adjustable set of modular core pattern controllers that are removable from the face of the outlet without the use of tools. Outlets shall be extruded aluminum construction. Steel border or cores are not acceptable. The units shall be the size and quantity as outline in the plans and specifications.

Outlets shall field adjustable to obtain 1, 2-way opposite, 2-way corner, 3, and 4-way directional air patterns.

Units shall be designed to integrate into the specified ceiling system.



# DCD - Directional Ceiling Diffusers

8/2006

Directional Ceiling Diffusers



DCD

## Accessories

### Optional Dampers

Aluminum opposed blade dampers shall be provided. Damper shall be adjusted using a handle accessible through the face of the diffuser. Screwdriver slot operators are not allowed.

## Performance Specification

The manufacturer shall provide published performance data. Data shall be tested in accordance to ANSI/ASHRAE Standard 70-1991.

## Paint Specification

Process shall be anodic electrodeposition using an anodic acrylic paint. Units shall undergo pre-treatment including a pressurized spray stage using an alkaline cleaner and a de-ionized water rinse.

Film Properties shall meet or exceed the following standards:

Property	Test Method	Performance
Film thickness		.8-1.0 mils
Film Cure		320 F @ 20 min
Gloss – 60 deg.	ASTM D523-89	70-80%
Pencil Hardness	ASTM D3363-92A	HB-H
Crosshatch Adhesion	ASTM D3359-95	4B-5B
Direct Impact	ASTM D2794-93	100 in.lbs. Min
Reverse Impact	ASTM D2794-93	60 in.lbs. Min.
Salt Spray	ASTM B117-95	48-96 Hours
Humidity	ASTM D1735-92	500 Hours
Water Soak	ASTM D870-92	250 Hours

## Series 9000 - Model Specification Guide

### Square/Rectangular Modular Core Ceiling Diffusers

#### Series 9000 - Aluminum

Model	Available Neck	Air Pattern	Available Finishes	Available Options	
9000-1 - Flush Surface Mount 9000-2 - Beveled Surface Mount	6" thru 48"	Standard	Standard	OBD	Opposed Blade Damper - Steel
		S4 - 4 Core	01 - White	OBDA	Opposed Blade Damper - Aluminum
		Optional	Optional	L9	Equalizing Grid
		S1 - 1-way	02 - Aluminum	TR Deep	Square to Round Transition - Deep
		S2 - 2-way	03 - Black		
		S3 - 3-way	28 - Custom Color		

Model	Available Neck	Module	Air Pattern	Available Finishes	Available Options	
9000-6 - T-bar Lay-in	6" x 6" thru 20" x 20"	24" x 24"	Standard	Standard	OBD	Opposed Blade Damper - Steel
9000-7 - Concealed Spline	6" x 6" thru 18" x 18"		S4 - 4 Core	01 - White	OBDA	Opposed Blade Damper - Aluminum
9000-8 - Tegular T-bar			Optional	L9	Equalizing Grid	
9000-9 - Donn Finline			02 - Aluminum	TR Deep	Square to Round Transition - Deep	
			03 - Black			
		28 - Custom Color				



PERFORATED  
CEILING  
DIFFUSERS

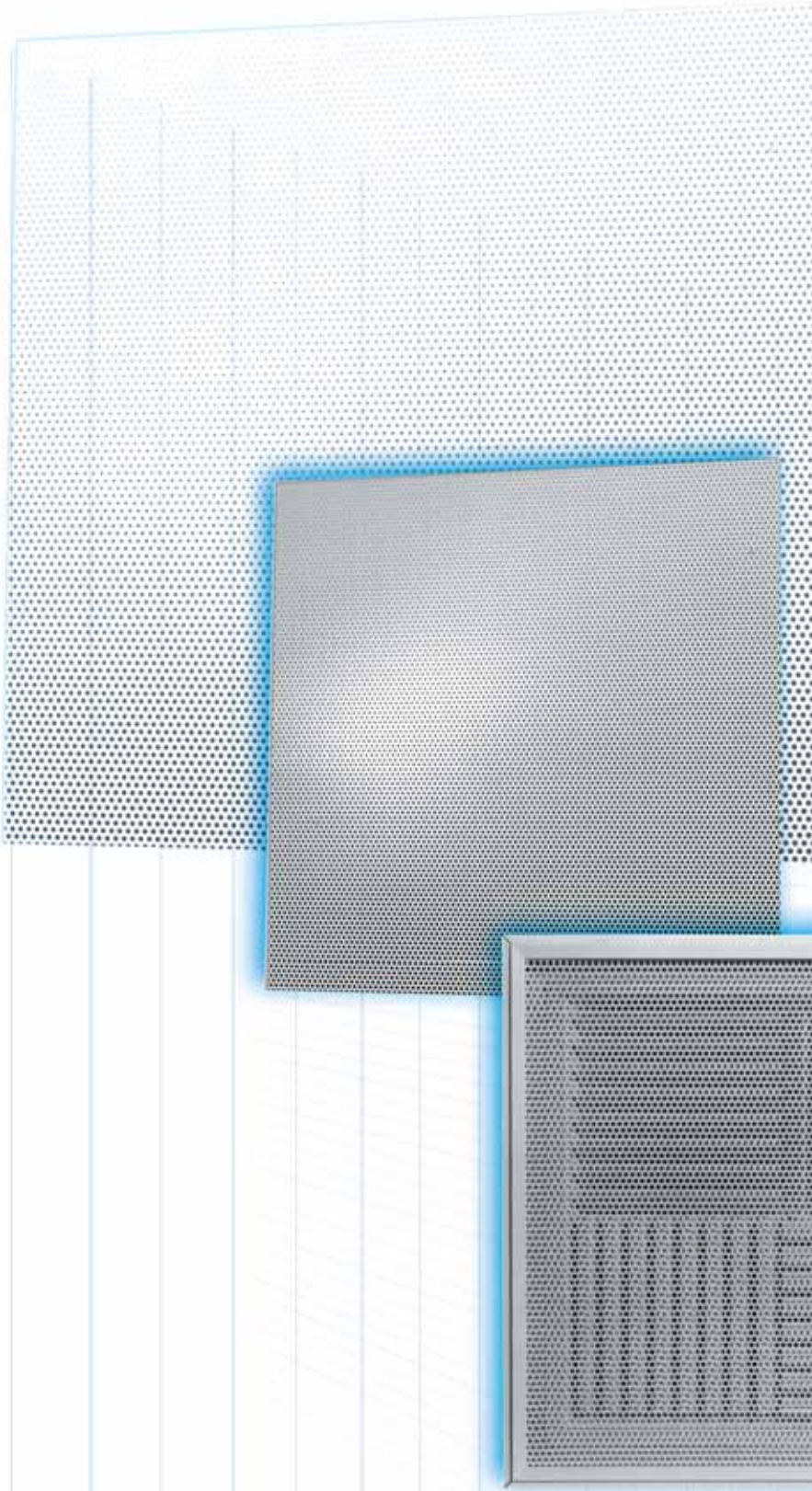

**PERFORATED  
CEILING DIFFUSERS**

PERFORATED  
CEILING DIFFUSERS



**Model 7000**  
Pg. 104

Series 7000 - Supply  
Series 7000R - Return

## Perforated Supply - Extruded Aluminum - Curved Blade Pattern Controller - Series 7000

- ★ The series 7000 is an aluminum, perforated supply diffuser with curved blade pattern controllers mounted in the neck of the diffuser. Pattern controllers are adjustable from a horizontal to vertical discharge pattern
- ★ The face is secured with spring clips making removal and access to the pattern controllers easy
- ★ Units are available in 1-way, 2-way opposite, 2-way corner, 3-way, and 4-way patterns
- ★ The Series 7000 generates a "star pattern" directional discharge of air maximizing induction and room air mixing
- ★ T-bar Lay-in border type 6 is designed to be installed in standard 15/16" tee. This border type 6 can be used in surface mounting applications by adding optional T-bar plaster frame (TBPF)
- ★ Matching returns available: 7000R
- ★ The series 7000 is an excellent choice for VAV applications

Supply		Return	
7000-1 Surface Mount	7000-8 Tegular T-bar	7000R-1 Surface Mount	7000R-8 Tegular T-bar
7000-6 T-bar Lay-in	7000-9 Donn Finline	7000R-6 T-bar Lay-in	7000R-9 Donn Finline
7000-7 Concealed T-bar		7000R-7 Concealed T-bar	



**Model PRTB**  
Pg. 112

Series PRTB - Aluminum  
Series SPRTB - Steel

## Perforated Screen - Non-Ducted - Return - Aluminum/Steel - Series PRTB

- ★ The series PRTB is an economical choice for non-duct plenum return applications and is shipped without pattern controllers
- ★ Unit can be used in surface mounting applications by adding optional T-bar plaster frame (TBPF)

Aluminum	Steel
PRTB-6 T-bar Lay-in	SPRTB-6 T-bar Lay-in
PRTB-8 Tegular T-bar	SPRTB-8 Tegular T-bar
PRTB-9 Donn Finline	SPRTB-9 Donn Finline



**Model 7300**  
Pg. 114

## Perforated Supply/Return Diffuser - Fiberglass Backpan - Series 7300

- ★ The series 7300 perforated supply diffuser is an economical diffuser with a fiberglass plenum designed to allow field installation of the inlet collar (by others). The face of the diffuser is non-removable and includes a pattern controller set for a circular 360° degree round discharge pattern
- ★ The series 7300 provides a 360° tight horizontal circular pattern along the ceiling
- ★ The series 7300 includes a T-bar Lay-in border type 6 which is designed to be installed in standard 15/16" tee
- ★ Border type 6 can be used in surface mounting applications by adding optional T-bar plaster frame (TBPF)
- ★ Matching returns available: 7300R
- ★ The series 7300 is an excellent choice for VAV applications

T-bar Lay-in
7300-6 Fixed Steel Face
7300-6 AF Fixed Aluminum Face



**Model 7350**  
Pg. 116

## Perforated Supply/Return Diffuser - Fiberglass Backpan - Series 7350

- ★ The series 7350 perforated supply diffuser is an economical diffuser with a fiberglass plenum designed to allow field installation of the inlet collar (by others)
- ★ The face diffuser includes a hinged removable face and 4 pattern controllers that can adjusted for a 1-way, 2-way opposite, 2-way corner, 3-way, and 4-way discharge air patterns
- ★ Set in a 4-way pattern, the 7350 provides a 360° tight horizontal circular pattern along the ceiling
- ★ The series 7350 includes a T-bar Lay-in border type 6 designed to be installed in standard 15/16" tee
- ★ Border type 6 can be used in surface mounting applications by adding optional T-bar Plaster Frame (TBPF)
- ★ Matching returns available: 7350R
- ★ The series 7350 is an excellent choice for VAV applications

	Supply	Return
T-bar Lay-in	7350-6 Hinged Steel Removable Face	7350R-6 Hinged Steel Removable Face
	7350-6 AF Hinged Aluminum Removable Face	7350R-6 AF Hinged Aluminum Removable Face
Tegular T-bar	7350-8 Hinged Steel Removable Drop Face	7350R-8 Hinged Steel Removable Drop Face



# PCD - Perforated Ceiling Diffusers



**Model 7500**  
Pg. 118

**Round Neck**  
Series 7500 - Supply  
Series 7500R - Return

**Square Neck**  
Series 7550 - Supply  
Series 7550R - Return

## Perforated Ceiling Diffuser - Face Mounted Adjustable Pattern Controller - Series 7500

- ✦ The series 7500 and 7550 perforated supply diffusers have 4 adjustable pattern controllers mounted on the face of the diffuser.
- ✦ Series 7500 are round neck diffusers; series 7550 are square neck diffusers
- ✦ The hinged, fully removable face allow access to the pattern controllers
- ✦ Unit can be adjusted for 1-way, 2-way opposite, 2-way corner, 3-way, and 4-way patterns  
In 4-way pattern, Series 7500 provides a 360° tight horizontal circular pattern along the ceiling
- ✦ T-bar Lay-in border type 6 is designed to be installed in standard 15/16" tee
- ✦ Border type 6 can be used in surface mounting applications by adding optional T-bar plaster frame (TBPF)
- ✦ Matching returns available: 7500R (round neck) and 7550R (square neck)
- ✦ The series 7500 and 7550 are excellent choices for VAV applications

Round Neck			
Supply		Return	
7500-1 Surface Mount	7500-8 Tegular T-bar	7500R-1 Surface Mount	7500R-8 Tegular T-bar
7500-1 DF Surface Mount - Drop Face	7500-8 AF Tegular T-bar - Aluminum Face	7500R-1 DF Surface Mount - Drop Face	7500R-8 AF Tegular T-bar - Aluminum Face
7500-1 AF Surface Mount - Aluminum Face	7500-8 AL Tegular T-bar -All Aluminum	7500R-1 AF Surface Mount - Aluminum Face	7500R-8 AL Tegular T-bar - All Aluminum
7500-6 T-bar Lay-in	7500-9 Donn Fineline	7500R-6 T-bar Lay-in	7500R-9 Donn Fineline
7500-6 AF T-bar Lay-in - Aluminum Face	Metric	7500R-6 AF T-bar Lay-in - Aluminum Face	Metric
7500-6 AL T-bar Lay-in - All Aluminum	M-7000-6 T-bar Lay-in - 600mm x 600mm	7500R-6 AL T-bar Lay-in - All Aluminum	M-7500R-6 T-bar Lay-in - 600mm x 600mm

Square Neck			
Supply		Return	
7550-1 Surface Mount	7550-8 Tegular T-bar	7550R-1 Surface Mount	7550R-8 Tegular T-bar
7550-1 DF Surface Mount - Drop Face	7550-8 AF Tegular T-bar - Aluminum Face	7550R-1 DF Surface Mount - Drop Face	7550R-8 AF Tegular T-bar - Aluminum Face
7550-1 AF Surface Mount - Aluminum Face	7550-8 AL Tegular T-bar - All Aluminum	7550R-1 AF Surface Mount - Aluminum Face	7550R-8 AL Tegular T-bar - All Aluminum
7550-6 T-bar Lay-in	7550-9 Donn Fineline	7550R-6 T-bar Lay-in	7550R-9 Donn Fineline
7550-6 AF T-bar Lay-in - Aluminum Face	Metric	7550R-6 AF T-bar Lay-in - Aluminum Face	Metric
7550-6 AL T-bar Lay-in - All Aluminum	M-7550-6 T-bar Lay-in - 600mm x 600mm	7550R-6 AL T-bar Lay-in - All Aluminum	M-7550R-6 T-bar Lay-in - 600mm x 600mm



**Model 7600**  
Pg. 134

**Round Neck**  
Series 7600 - Supply  
Series 7600R - Return

**Square Neck**  
Series 7650 - Supply  
Series 7650R - Return

## Perforated Ceiling Diffuser - Curved Blade - Neck Mounted Pattern Controller - Series 7600

- ✦ The Series 7600 and 7650 perforated supply diffusers have curved blade pattern controllers mounted in the neck of the diffuser. Pattern controllers are adjustable from a horizontal to vertical discharge pattern
- ✦ Series 7600 are round neck diffusers; series 7650 are square neck diffusers
- ✦ The hinged, fully removable face allow access to the pattern controllers
- ✦ Units are available in 1-way, 2-way opposite, 2-way corner, 3-way, and 4-way patterns. The 4-way core can be set for corner or side discharge patterns. The series 7600 and 7650 provide a "star pattern" directional discharge of air maximizing induction and room air mixing
- ✦ T-bar Lay-in border type 6 is designed to be installed in standard 15/16" tee
- ✦ Border type 6 can be used in surface mounting applications by adding optional T-bar plaster frame (TBPF)
- ✦ Matching returns available: 7600R (round neck) and 7650R (square neck)
- ✦ The series 7600 and 7650 are excellent choices for VAV applications

Round Neck			
Supply		Return	
7600-1 Surface Mount	7600-8 Tegular T-bar	7600R-1 Surface Mount	7600R-8 Tegular T-bar
7600-1 DF Surface Mount - Drop Face	7600-8 AF Tegular T-bar - Aluminum Face	7600R-1 DF Surface Mount - Drop Face	7600R-8 AF Tegular T-bar - Aluminum Face
7600-1 AF Surface Mount - Aluminum Face	7600-8 AL Tegular T-bar - All Aluminum	7600R-1 AF Surface Mount - Aluminum Face	7600R-8 AL Tegular T-bar - All Aluminum
7600-6 T-bar Lay-in	7600-9 Donn Fineline	7600R-6 T-bar Lay-in	7600R-9 Donn Fineline
7600-6 AF T-bar Lay-in - Aluminum Face	Metric	7600R-6 AF T-bar Lay-in - Aluminum Face	Metric
7600-6 AL T-bar Lay-in - All Aluminum	M-7600-6 T-bar Lay-in - 600mm x 600mm	7600R-6 AL T-bar Lay-in - All Aluminum	M-7600R-6 T-bar Lay-in - 600mm x 600mm

Square Neck			
Supply		Return	
7650-1 Surface Mount	7650-8 Tegular T-bar	7650R-1 Surface Mount	7650R-8 Tegular T-bar
7650-1 DF Surface Mount - Drop Face	7650-8 AF Tegular T-bar - Aluminum Face	7650R-1 DF Surface Mount - Drop Face	7650R-8 AF Tegular T-bar - Aluminum Face
7650-1 AF Surface Mount - Aluminum Face	7650-8 AL Tegular T-bar -All Aluminum	7650R-1 AF Surface Mount - Aluminum Face	7650R-8 AL Tegular T-bar - All Aluminum
7650-6 T-bar Lay-in	7650-9 Donn Fineline	7650R-6 T-bar Lay-in	7650R-9 Donn Fineline
7650-6 AF T-bar Lay-in - Aluminum Face	Metric	7650R-6 AF T-bar Lay-in - Aluminum Face	Metric
7650-6 AL T-bar Lay-in - All Aluminum	M-7650-6 T-bar Lay-in - 600mm x 600mm	7650R-6 AL T-bar Lay-in - All Aluminum	M-7650R-6 T-bar Lay-in - 600mm x 600mm



**Model 7900**  
Pg. 150

## Perforated Face Modular Core Diffuser - Aluminum - Series 7900

- ✦ The series 7900 is an aluminum, perforated modular core supply diffuser. Modular cores can be field adjusted for 1-way, 2-way opposite, 2-way corner, 3-way, and 4-way air discharge patterns
- ✦ The perforated face is secured with spring clips making removal and access to the modular core pattern controllers easy
- ✦ T-bar Lay-in border type 6 is designed to be installed in standard 15/16" tee
- ✦ Border type 6 can be used in surface mounting applications by adding optional T-bar plaster frame (TBPF)
- ✦ Matching returns available: 7900R
- ✦ The series 7900 is an excellent choice for VAV applications

Supply	
7900-1	Surface Mount
7900-6	T-bar Lay-in
7900-7	Concealed Spline
7900-8	Tegular T-bar



**Model 7950**  
Pg. 156

## Perforated Face Modular Core Diffuser - Aluminum Deflectors/Steel Backpan - Square Neck - Series 7950

- ✦ The series 7950 perforated modular core supply diffuser with a steel backpan. Modular cores can be field adjusted for 1-way, 2-way opposite, 2-way corner, 3-way, and 4-way air discharge patterns
- ✦ The perforated face is secured with spring clips making removal and access to the modular core pattern controllers easy
- ✦ T-bar Lay-in border type 6 is designed to be installed in standard 15/16" tee
- ✦ Border type 6 can be used in surface mounting applications by adding optional T-bar plaster frame (TBPF)
- ✦ Matching returns available: 7950R
- ✦ The 7950 is an excellent choice for VAV applications

Supply			
7950-1	Surface Mount	7950-8	Tegular T-bar
7950-1 DF	Surface Mount - Drop Face	7950-8 AF	Tegular T-bar - Aluminum Face
7950-1 AF	Surface Mount - Aluminum Face	7950-9	Donn Finline
7950-6	T-bar Lay-in		
7950-6 AF	T-bar Lay-in - Aluminum Face		



**Model 7550R-F**  
Pg. 160

## Perforated Filter Return Diffuser - Square Neck - Steel Series 7550R-F/7650R-F

- ✦ Unit can be used in surface mounting applications by adding optional T-bar plaster frame (TBPF)
- ✦ T-bar Lay-in border type 6 is designed to be installed in standard 15/16" tee
- ✦ The hinged, perforated face, allows access to the filter (by others)

Filter Return			
7550R-1 F	Surface Mount - Filter Back	7650R-1 F	Surface Mount - Filter Back
7550R-6 F	T-bar Lay-in - Filter Back	7650R-6 F	T-bar Lay-in - Filter Back
7550R-8 F	Tegular T-bar - Filter Back	7650R-8 F	Tegular T-bar - Filter Back

# LEADING THE INDUSTRY IN PRODUCT LITERATURE

With the choice of our Pre-Flite Catalog, Quick Select Catalog, InfoSource Catalog, InfoSource CD and our web site, [www.metalaire.com](http://www.metalaire.com), you pick the format for product information that best suits your air distribution design needs.

## Pre-Flite - Product Overview Catalog

The METALAIRES Pre-Flite catalog is a condensed reference guide containing concise listings of our entire product line including grilles, registers, diffusers, and air terminal units. This catalog can be used to help select the type of device, along with available border styles. The catalog includes photos of each model along with the features and model guide, a great tool when you are trying to select a device for your project.



## Quick Select Catalog - Air Distribution Selection Made Easy

The METALAIRES Quick Select Catalog is designed to save you time selecting air distribution equipment. This catalog is a compact version of our InfoSource Catalogs and includes drawings and performance for our most popular products. The Quick Select Catalog is broken into product types with each section beginning with a model summary that includes features and benefits of our products. To obtain product information not included in the Quick Select Catalog, simply go to our web site at [www.metalaire.com](http://www.metalaire.com).



## InfoSource Catalog Suite - Complete guide to Air Distribution Selection

The METALAIRES InfoSource Catalog suite is the leading product catalog in the industry. Included in these catalogs are the complete product listings, drawings, product features and benefits, product performance data, specifications, and model specifications. These catalogs are organized to make it quick and easy to find the information you are looking for.

### InfoSource Catalog Suite

- Ceiling Diffusers Catalog
- Grilles & Registers Catalog
- Air Terminal Unit Catalog
- Formations Catalog



## InfoSource CD

Our InfoSource CD has set the standard in the industry for air distribution product selection. This CD contains a complete library of all our catalogs and submittals along with our air terminal unit selection program.



## Web Site: [www.metalaire.com](http://www.metalaire.com)

METALAIRES leads the industry with a web site that contains all the product literature and performance data needed to design your air distribution system. Our web site includes all our submittals, catalogs, installation manuals, as well as other valuable information to aid you in air distribution design.



# PCD - Perforated Ceiling Diffusers

8/2006

- ➔ Perforated ➔ Series 7000 ➔ Supply Aluminum
- ➔ Series 7000R ➔ Return/Exhaust Aluminum

## Product Details

- ★ The series 7000 is an aluminum, perforated supply diffuser with curved blade pattern controllers mounted in the neck of the diffuser. Pattern controllers are adjustable from a horizontal to vertical discharge pattern
- ★ The face is secured with spring clips making removal and access to the pattern controllers easy
- ★ Units are available in 1-way, 2-way opposite, 2-way corner, 3-way, and 4-way patterns
- ★ The Series 7000 generates a "star pattern" directional discharge of air maximizing induction and room air mixing
- ★ Matching returns available: 7000R
- ★ The series 7000 is an excellent choice for VAV applications



**Model 7000-6**  
Standard Finish: 01 White

Perforated Ceiling Diffusers



PCD

## Supply

Dimensions are in inches

### Supply - Perforated Ceiling Diffuser - Surface Mount Model 7000-1

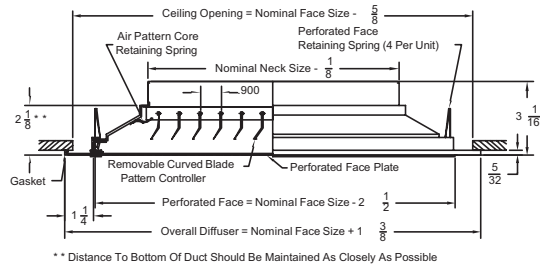

### Supply - Perforated Ceiling Diffuser - T-bar Lay-in Model 7000-6 - All sizes except 24" x 24"

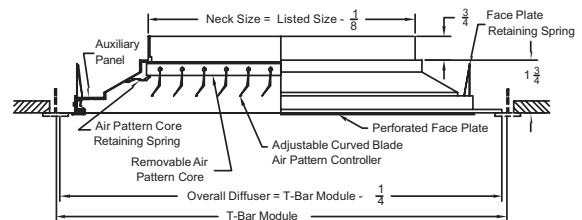

### Supply - Perforated Ceiling Diffuser - T-bar Lay-in Model 7000-6 - 24" x 24" Grid Size

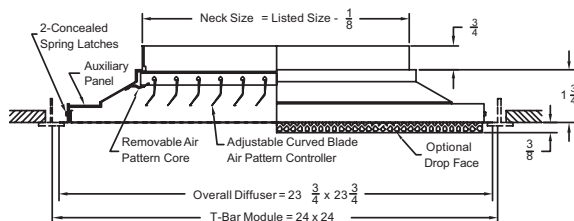

### Supply - Perforated Ceiling Diffuser - Concealed Spline Model 7000-7

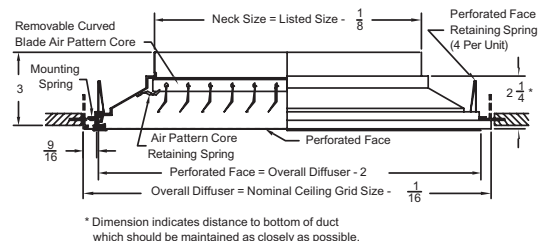

# PCD - Perforated Ceiling Diffusers



**Supply - Perforated Ceiling Diffuser - Tegular T-bar**  
Model 7000-8

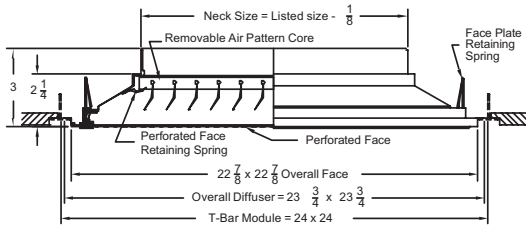

**Supply - Perforated Ceiling Diffuser - Donn Finline**  
Model 7000-9

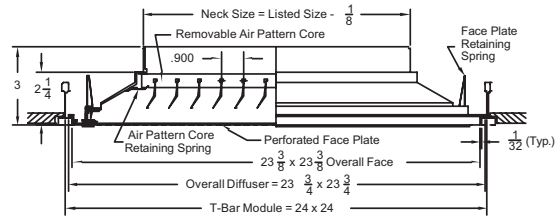

## Air Patterns - Perforated Ceiling Diffusers

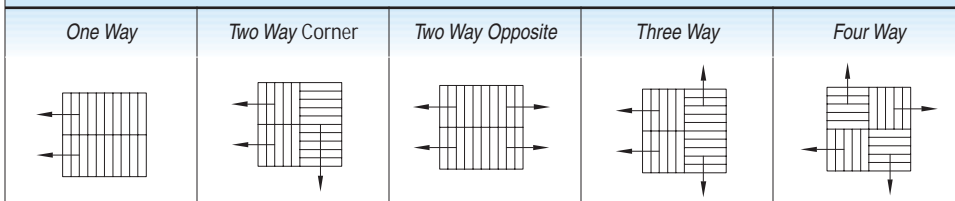

1. Available Finishes	2. Available Accessories	3. Construction Details
<p><b>Standard Finish:</b> 01 White</p> <p><b>Optional Finish</b> 02 Aluminum paint 03 Black 22 (BBP) Black back pan/white face &amp; border 28 Custom color</p>	<p>(Accessories Shipped Unattached)</p> <p><b>Square Neck:</b> D7 - Opposed blade damper - Steel ..... .337 D7A - Opposed blade damper - Aluminum . . .337 L9 - Equalizing grid ..... .334 TR - Square to round transition ..... .338</p> <p><b>Round Neck:</b> BDS - Butterfly damper ..... .335 RSD - Radial shutter damper ..... .336 G3 - Equalizing grid ..... .337</p>	<ul style="list-style-type: none"> <li>Available core patterns: 1W, 2W, 2C (Corner), 3W and 4W</li> <li>7600 Series has 3/16" diameter holes on 1/4" staggered centers</li> </ul>

# PCD - Perforated Ceiling Diffusers

8/2006

Perforated Ceiling Diffusers



PCD

## Return

**Return - Perforated Ceiling Diffuser - Surface Mount**  
 Model 7000R-1 - For units with neck sizes less than nominal face -2"

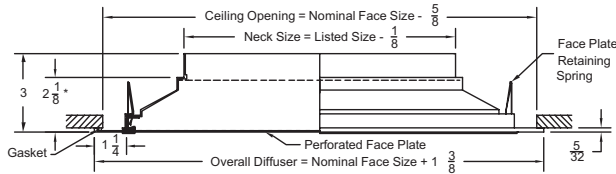

**Return - Perforated Ceiling Diffuser - Surface Mount**  
 Model 7000R-1\* - For units with neck sizes less than nominal face -2"

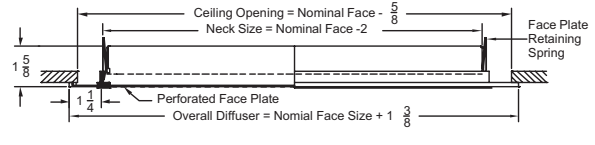

**Return - Perforated Ceiling Diffuser - T-bar Lay-in**  
 Model 7000R-6 - All sizes except 24" x 24"

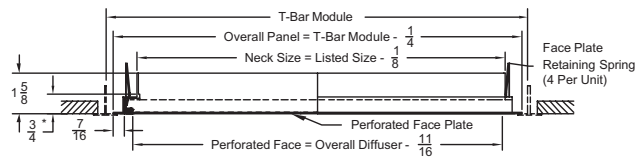

**Return - Perforated Ceiling Diffuser - T-bar Lay-in**  
 Model 7000R-6\* - 24" x 24" grid size only

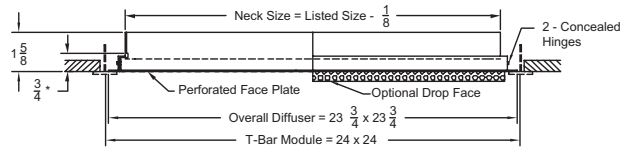

**Return - Perforated Ceiling Diffuser - Concealed Spline**  
 Model 7000R-7

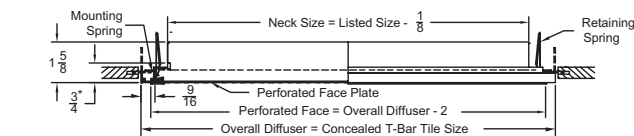

\* Distance To Bottom Of Duct Should Be Maintained as Closely As Possible

**Return - Perforated Ceiling Diffuser - Tegular T-bar**  
 Model 7000R-8

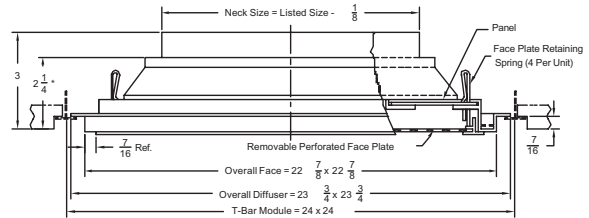

**Return - Perforated Ceiling Diffuser - Donn Finline**  
 Model 7000R-9 - Low profile

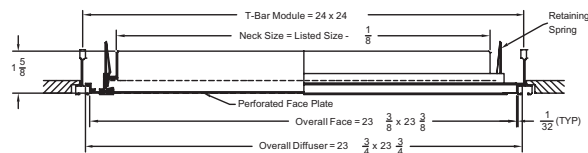



# PCD - Perforated Ceiling Diffusers

1. Available Finishes	2. Available Accessories	3. Construction Details
<b>Standard Finish:</b> 01 White <b>Optional Finish</b> 02 Aluminum paint 03 Black 22 (BBP) Black back pan/white face & border 28 Custom color  <b>Note:</b> Anodized Finish not available	Accessories are shipped unattached <b>Square Neck:</b> D7 - Opposed Blade Damper - Steel . . . . .337 D7A - Opposed Blade Damper - Aluminum . . .337 TR - Square to Round Transition . . . . .338 <b>Round Neck:</b> BDS - Butterfly Damper . . . . .335 RSD - Radial Shutter Damper . . . . .336	• Series 7000R has 3/16" diameter holes on 1/4" staggered centers

## Series 7000 - Available Sizes

### Model 7000-1 (Surface Mount)

Nominal Face Size	Actual Overall Face Size	Neck Sizes Available												
		6 x 6	8 x 8	9 x 9	10 x 10	12 x 12	14 x 14	15 x 15	16 x 16	18 x 18				
12 x 12	13 3/8 x 13 3/8	6 x 6	8 x 8											
14 x 14	15 3/8 x 15 3/8	6 x 6	8 x 8											
15 x 15	16 3/8 x 16 3/8	6 x 6	8 x 8	9 x 9										
16 x 16	17 3/8 x 17 3/8	6 x 6	8 x 8	9 x 9	10 x 10									
18 x 18	19 3/8 x 19 3/8	6 x 6	8 x 8	9 x 9	10 x 10	12 x 12								
20 x 20	21 3/8 x 21 3/8	6 x 6	8 x 8	9 x 9	10 x 10	12 x 12	14 x 14							
21 x 21	22 3/8 x 22 3/8	6 x 6	8 x 8	9 x 9	10 x 10	12 x 12	14 x 14	15 x 15						
24 x 12	25 3/8 x 13 3/8	6 x 6	8 x 6	9 x 6	10 x 6	12 x 6	14 x 6	16 x 6	18 x 6					
24 x 24	25 3/8 x 25 3/8	6 x 6	8 x 8	9 x 9	10 x 10	12 x 12	14 x 14	15 x 15	16x16	18 x 18				
36 x 12	37 3/8 x 13 3/8	6 x 6	8 x 6	9 x 6	10 x 6	12 x 6	14 x 6	16 x 6	18 x 6					
36 x 24	37 3/8 x 25 3/8	6 x 6	8 x 8	9 x 9	10 x 10	12 x 12	14 x 14	15 x 15	16x16	18 x 18				
48 x 12	49 3/8 x 13 3/8	6 x 6	8 x 6	9 x 6	10 x 6	12 x 6	14 x 6	16 x 6	16x6	18 x 6				
48 x 24	49 3/8 x 25 3/8	6 x 6	8 x 8	9 x 9	10 x 10	12 x 12	14 x 14	15 x 15	16x16	18 x 18				

### Model 7000-7 (Concealed T-bar)

T-Bar Spacing	Actual Overall Face Size	Neck Sizes Available									
		6 x 6	8 x 8	9 x 9	10 x 10	12 x 12	14 x 14	15 x 15	16x16	18 x 18	
12 x 12	11 15/16 x 11 15/16	6 x 6	8 x 8								
24 x 12	23 15/16 x 11 15/16	6 x 6	8 x 6	9 x 6	10 x 6	12 x 6	14 x 6	16 x 6	18 x 6		
24 x 24	23 15/16 x 23 15/16	6 x 6	8 x 8	9 x 9	10 x 10	12 x 12	14 x 14	15 x 15	16x16	18 x 18	
36 x 12	35 15/16 x 11 15/16	6 x 6	8 x 6	9 x 6	10 x 6	12 x 6	14 x 6	15 x 6	16x6	18x6	
36 x 24	35 15/16 x 23 15/16	6 x 6	8 x 8	9 x 9	10 x 10	12 x 12	14 x 14	15 x 15	16x16	18 x 18	
48 x 12	47 15/16 x 11 15/16	6 x 6	8 x 6	12 x 6	14 x 6	16 x 6	18 x 6				
48 x 24	47 15/16 x 23 15/16	6 x 6	8 x 8	9 x 9	10 x 10	12 x 12	14 x 14	15 x 15	16x16	18 x 18	

### Model 7000-6 (T-bar Lay-in)

T-Bar Spacing	Actual Overall Face Size	Neck Sizes Available									
		6 x 6	8 x 8	9 x 9	10 x 10	12 x 12	14 x 14	15 x 15	16 x 16	18 x 18	
12 x 12	11 15/16 x 11 15/16	6 x 6	8 x 8								
24 x 12	23 15/16 x 11 15/16	6 x 6	8 x 6	9 x 6	10 x 6	12 x 6	14 x 6	15 x 6	16 x 6	18 x 6	
24 x 24	23 15/16 x 23 15/16	6 x 6	8 x 8	9 x 9	10 x 10	12 x 12	14 x 14	15 x 15	16 x 16	18 x 18	
36 x 12	35 15/16 x 11 15/16	6 x 6	8 x 6	9 x 6	10 x 6	12 x 6	14 x 6	15 x 6	16 x 6	18 x 6	
36 x 24	35 15/16 x 23 15/16	6 x 6	8 x 8	9 x 9	10 x 10	12 x 12	14 x 14	15 x 15	16 x 16	18 x 18	
48 x 12	47 15/16 x 11 15/16	6 x 6	8 x 6	9 x 6	10 x 6	12 x 6	14 x 6	15 x 6	16 x 6	18 x 6	
48 x 24	47 15/16 x 23 15/16	6 x 6	8 x 8	9 x 9	10 x 10	12 x 12	14 x 14	15 x 15	16 x 16	18 x 18	

### Model 7000-8 (Tegular T-bar)

### Model 7000-9 (Donn Finline)

T-Bar Spacing	Actual Overall Face Size	Neck Sizes Available							
	Face Size	6 x 6	8 x 8	9 x 9	10 x 10	12 x 12	14 x 14	15 x 15	22 x 22
24 x 24	22 7/8 x 22 7/8	6 x 6	8 x 8	9 x 9	10 x 10	12 x 12	14 x 14	15 x 15	22 x 22

See Page PCD-109 for Series 7000 Performance Notes

# PCD - Perforated Ceiling Diffusers

## Series 7000 - Performance

Models 7000 (-1, -6, -7, -8, -9)

Perforated Ceiling Diffusers



PCD

Neck Size Ak	fpm Neck Velocity Pv	200 .003	300 .006	400 .010	500 .016	600 .022	700 .030	800 .040	900 .050
6" x 6"	CFM Pt NC	50 .015 <	75 .03 <	100 .06 20	125 .09 25	150 .13 25	175 .17 30	200 .23 35	225 .29 40
	Throw	4-Way 3-Way 2-Way 1-Way	1-1-3 1-2-3 2-3-4 3-4-5	2-3-4 2-3-4 3-4-5 4-5-7	3-4-5 3-5-6 4-5-7 5-7-9	3-5-6 4-5-7 4-5-7 6-8-11	4-5-7 5-7-9 6-9-12 7-11-14	4-6-8 6-8-10 7-10-13 8-12-16	5-7-9 6-9-12 7-10-13 9-14-18
8" x 6" 9" x 6"	CFM Pt NC	65 .015 <	100 .03 <	130 .06 20	165 .09 25	200 .13 25	230 .18 30	265 .23 35	300 .29 40
	Throw	4-Way 3-Way 2-Way 1-Way	2-3-4 3-4-5 3-4-5 3-5-6	3-4-5 3-4-5 3-5-6 4-6-8	3-5-6 4-5-7 4-6-8 5-7-10	4-5-7 4-6-8 5-7-10 6-9-12	4-6-8 5-7-10 7-10-13 8-12-15	5-7-9 6-9-12 7-11-14 9-13-17	5-7-10 7-10-13 8-12-16 10-15-19
8" x 8" 10" x 6"	CFM Pt NC	90 .016 <	130 .033 <	180 .06 20	220 .09 25	265 .13 30	310 .18 35	350 .24 40	400 .30 40
	Throw	4-Way 3-Way 2-Way 1-Way	2-4-5 2-3-4 3-5-6 4-5-7	3-5-6 3-5-6 4-6-8 5-7-9	4-5-7 4-6-8 6-8-11 6-9-12	4-6-8 5-7-9 7-10-13 8-12-15	5-7-9 6-8-11 8-12-15 9-14-18	6-8-11 7-11-14 9-14-18 11-16-22	7-10-13 8-12-16 11-16-21 12-18-24
12" x 6"	CFM Pt NC	100 .016 <	150 .032 <	200 .06 20	250 .09 25	300 .13 30	350 .18 35	400 .24 40	450 .30 40
	Throw	4-Way 3-Way 2-Way 1-Way	3-4-5 3-4-5 3-5-6 4-5-7	3-5-6 4-5-7 4-6-8 5-7-9	4-6-8 5-7-9 6-8-11 6-9-12	5-7-9 5-7-10 7-10-13 8-12-15	5-7-10 6-9-12 8-12-15 9-14-18	6-9-12 8-12-15 9-14-18 11-16-22	7-11-14 9-13-17 11-16-21 13-19-25
9" x 9" 14" x 6"	CFM Pt NC	115 .016 <	175 .042 <	230 .06 20	290 .09 25	350 .137 30	405 .18 35	465 .24 40	520 .30 40
	Throw	4-Way 3-Way 2-Way 1-Way	3-5-6 3-5-6 4-6-7 4-6-8	4-5-7 4-6-8 5-7-9 5-7-10	5-7-9 5-7-10 6-9-12 7-10-13	5-7-10 6-8-11 7-11-14 8-12-16	6-9-12 7-10-13 8-12-16 10-15-19	7-10-13 8-12-16 10-15-19 11-16-22	8-12-15 9-14-18 11-16-22 13-19-25
10" x 10" 15" x 6" 16" x 6"	CFM Pt NC	140 .016 <	210 .035 <	275 .06 20	345 .10 25	415 .14 30	485 .19 35	550 .25 40	620 .31 40
	Throw	4-Way 3-Way 2-Way 1-Way	2-3-4 3-5-6 4-6-8 5-7-9	3-5-6 4-6-8 6-8-11 6-9-12	4-6-8 5-7-10 7-10-13 8-12-16	6-8-11 7-10-13 8-12-16 10-15-20	6-9-12 7-10-13 8-12-15 10-15-20	7-11-14 9-14-18 12-17-23 14-21-28	8-12-16 10-15-20 13-19-26 16-24-32

Models 7000R (-1, -6, -7, -8, -9)

Neck Size Ak	fpm Neck Velocity Pv	200 -.013	300 -.03	400 -.05	500 -.08	600 -.011	700 -.015	800 -.020
6" x 6"	CFM NC	50 <	75 <	100 <	125 <	150 20	175 25	200 30
8" x 6"	CFM NC	65 <	100 <	130 <	165 <	200 20	230 25	265 30
8" x 8"	CFM NC	90 <	130 <	175 <	220 20	265 25	310 30	350 35
9" x 9"	CFM NC	110 <	170 <	225 <	280 20	335 25	390 30	450 35
10" x 6"	CFM NC	80 <	125 <	165 <	205 20	245 25	290 30	330 35
10" x 10"	CFM NC	140 <	210 <	275 <	345 20	415 25	485 30	550 35
12" x 6"	CFM NC	100 <	150 <	200 <	250 20	300 25	350 30	400 35
12" x 12"	CFM NC	200 <	300 <	400 <	500 20	600 25	700 30	800 35
15" x 15"	CFM NC	310 <	470 <	625 20	780 25	935 30	1090 35	1250 40
18" x 18"	CFM NC	450 <	675 <	900 20	1125 25	1350 30	1575 35	1800 40
20" x 20"	CFM NC	555 <	830 <	1110 20	1385 28	1660 33	1940 38	2215 42
22" x 10"	CFM NC	305 <	455 <	610 20	760 25	910 30	1065 35	1215 40
22" x 22"	CFM NC	670 <	1010 <	1345 20	1680 28	2015 33	2350 38	2690 42
34" x 22"	CFM NC	1040 <	1555 <	2075 20	2595 28	3115 35	3635 40	4150 45
46" x 22"	CFM NC	1405 <	2105 <	2810 23	3510 30	4210 38	4915 42	5615 445

See Page PCD-109 for Series 7000 Performance Notes



## Series 7000 - Performance

### Models 7000 (-1, -6, -7, -8, -9)

Neck Size Ak	fpm Neck Velocity Pv	200 Pt NC	300 .006	400 .010	500 .016	600 .022	700 .030	800 .040	900 .050	
18" x 6"	CFM	150	225	300	375	450	525	600	675	
	Pt	.016	.05	.06	.10	.14	.19	.25	.31	
	NC	<	<	20	25	30	35	40	40	
	Throw	4-Way	3-4-5	3-5-6	4-6-8	6-8-11	7-10-13	8-12-15	9-14-18	10-15-20
		3-Way	3-4-5	4-6-8	6-8-11	7-10-13	8-12-16	9-14-18	11-16-21	12-18-24
2-Way		4-6-8	6-8-11	7-11-14	9-13-17	11-16-21	12-18-24	14-21-28	18-27-33	
1-Way		5-7-9	6-9-12	8-12-16	11-16-21	13-19-25	15-22-29	17-25-33	19-28-38	
12" x 12"	CFM	200	300	400	500	600	700	800	900	
	Pt	.016	.045	.066	.10	.15	.20	.26	.33	
	NC	<	20	25	25	30	35	40	40	
	Throw	4-Way	3-5-6	4-6-8	5-7-10	6-9-12	8-12-15	9-13-17	10-15-20	12-17-23
		3-Way	3-5-6	5-7-9	6-9-12	8-12-15	9-14-18	11-16-22	13-19-25	14-20-27
2-Way		5-7-9	6-9-12	8-12-16	11-16-21	12-18-24	15-22-29	17-25-33	18-27-36	
1-Way		6-9-12	8-12-16	10-15-20	12-18-24	15-22-29	17-25-33	18-27-36	21-31-42	
14" x 14"	CFM	270	410	545	680	815	950	1090	1225	
	Pt	.018	.04	.07	.11	.16	.22	.28	.36	
	NC	<	20	25	28	33	37	40	43	
	Throw	4-Way	4-5-7	4-6-9	6-9-12	7-11-14	9-14-18	10-15-20	12-18-24	14-21-28
		3-Way	4-5-9	5-8-11	6-10-13	8-13-16	10-15-20	11-17-23	13-19-27	16-23-31
2-Way		5-7-10	6-9-13	8-12-18	11-17-22	12-19-26	16-23-31	18-26-36	19-29-39	
1-Way		6-9-12	8-12-18	10-15-22	13-19-26	15-23-30	17-25-35	19-28-39	21-31-43	
15" x 15"	CFM	310	470	625	780	935	1090	1250	1405	
	Pt	.018	.05	.07	.11	.16	.21	.28	.35	
	NC	<	20	25	30	35	40	40	45	
	Throw	4-Way	4-6-8	5-7-10	7-10-13	8-12-16	10-15-20	12-17-23	13-19-26	15-23-30
		3-Way	5-7-9	6-9-12	8-12-15	9-14-18	11-16-22	13-19-26	15-23-30	18-26-35
2-Way		6-9-12	9-14-15	12-17-20	13-19-26	16-22-31	18-27-36	20-30-40	23-33-43	
1-Way		7-11-14	9-14-18	11-18-22	14-21-28	16-24-32	19-28-38	21-31-42	23-34-45	
16" x 16"	CFM	355	590	710	885	1060	1240	1415	1595	
	Pt	.018	.047	.070	.109	.155	.212	.280	.350	
	NC	<	20	25	30	35	40	40	45	
	Throw	4-Way	5-7-9	6-8-11	8-10-14	9-13-18	10-15-21	13-18-27	14-20-28	16-22-31
		3-Way	5-7-11	6-9-13	8-13-17	10-15-22	13-19-26	15-22-30	18-25-36	19-29-39
2-Way		6-10-12	9-14-16	11-17-24	14-21-28	17-25-32	19-26-34	21-34-40	24-34-44	
1-Way		7-10-16	9-15-18	12-18-26	15-22-32	18-27-36	19-28-37	24-35-42	26-36-46	
18" x 18"	CFM	450	675	900	1125	1350	1575	1800	2025	
	Pt	.019	.05	.07	.11	.16	.22	.29	.36	
	NC	<	20	25	30	35	40	40	45	
	Throw	4-Way	5-7-10	6-9-12	8-12-16	10-15-20	12-18-24	14-21-28	16-24-32	18-27-36
		3-Way	5-7-12	7-11-14	9-14-18	11-16-22	13-19-26	16-24-31	18-27-36	21-31-41
2-Way		8-12-18	10-15-20	13-19-26	16-24-32	20-29-39	23-34-45	26-39-52	29-43-58	
1-Way		9-14-22	11-16-24	15-23-30	18-27-36	22-32-43	25-37-49	28-42-56	30-45-60	

### Series 7000 - Performance Notes:

All data are tested in accordance with ANSI/ASHRAE 70-1991

### Definition of Units:

- CFM - Cubic Feet per Minute (air)
- fpm - Velocity of air stream in Feet Per Minute
- Pv - Velocity pressure (inches of water column)
- Pt - Total pressure (inches of water column)
- Ps - Static pressure = Pt - Pv (inches of water column)
- Throw - Cataloged throw is horizontal distances in feet to the terminal velocities of 150, 100 and 50 fpm with supply air temperature 20° F below room air temperature
- NC - Noise criterion, sound pressure level. NC ratings are based on sound power level (Lw) RE: 10E-12 watts minus a 10 dB room attenuation in all octave bands
- Ak - Area Factor



## Series 7000 - Specification

### Supply – Perforated Face – Square Neck - Curved Pattern Controllers/*Series 7000*

7000-1 - Surface Mounted  
7000-6 - T-bar Lay-in  
7000-7 - Concealed Spline  
7000-8 - Tegular T-bar  
7500-9 - Donn Finline

Air Outlets shall be aluminum model 7000 manufactured by METALAIRE. Units shall consist of aluminum 51% free area perforated face and an aluminum border and backpan. Perforated holes shall be 3/16" diameter on 1/4" staggered centers.

Outer border of units shall be extruded aluminum construction. The perforated face shall be removable allowing access to aluminum curved blade pattern controller mounted into the neck of the diffusers. Face shall be secured in place with tension spring clips. Pattern controller blades shall be individually adjustable and allow the discharge pattern to be adjustable from vertical to horizontal. Pattern controller blades shall pivot in friction mounting retainers. Retainers shall hold the deflector blade position throughout the specified operating range of the device. Metal friction wires are not acceptable.

Outlets shall be available in 1, 2-way opposite, 2-way corner, 3, and 4-way directional air patterns. Units shall have square inlets.

The units shall be the size and quantity as outline in the plans and specifications.

Units shall be designed to integrate into the specified ceiling system.

### Return/Exhaust – Perforated Face – Square Neck/*Series 7000*

7000R-1 - Surface Mounted  
7000R-6 - T-bar Lay-in  
7000R-7 - Concealed Spline  
7000R-8 - Tegular T-bar  
7500R-9 - Donn Finline

Air Inlets shall be aluminum model 7000R manufactured by METALAIRE. Units shall consist of aluminum 51% free area perforated face and an aluminum border and backpan. Perforated holes shall be 3/16" diameter on 1/4" staggered centers. Units shall be designed for use in ducted return or exhaust applications.

Outer border of units shall be extruded aluminum construction. The perforated face shall be removable allowing access to interior of diffuser. Face shall be secured in place with tension spring clips.

The units shall be the size and quantity as outline in the plans and specifications.

Units shall be designed to integrate into the specified ceiling system.

### Square Neck Options and Accessories:

#### **Opposed Blade Damper**

METALAIRE model D7A aluminum or D7 steel round opposed blade type dampers shall be provided. Damper shall consist of gang operated blades that can be adjusted from full open to full closed. Damper shall be adjusted with a handle accessible by opening the face of the diffuser.

#### **Equalizing Grid**

METALAIRE model L9 aluminum square equalizing grid shall be provided. Equalizing grid shall consist aluminum blades mounting in an aluminum frame.

### Round Neck Optional Dampers and Accessories:

#### **Square to Round Transitions**

Units to have square to round transitions allowing installation with round ductwork.

#### **Butterfly Damper**

METALAIRE model BDS aluminum round butterfly type dampers shall be provided. Damper shall consist of two butterfly style blades that can be adjusted from full open to full closed. Damper shall be adjusted with a screw driver slot that can be assessed through the face of the diffuser.

#### **Radial Shutter Damper**

METALAIRE model RSD steel round radial shutter damper shall be provided. Damper shall consist of gang operated radial blades that slide perpendicular to air flow direction. The damper shall be adjusted from full open to full closed. Damper shall be adjusted with a screw driver slot that can be assessed through the face of the diffuser.

#### **Opposed Blade Damper**

METALAIRE model D3 aluminum or SD3 steel round opposed blade type dampers shall be provided. Damper shall consist of gang operated blades that can be adjusted from full open to full closed. Damper shall be adjusted with a screw driver slot that can be assessed through the face of the diffuser.

#### **Equalizing Grid**

METALAIRE model G3 aluminum round equalizing grid shall be provided. Equalizing grid shall consist of 1/2" x 1/2" x 1/2" aluminum cubed core mounting in an aluminum frame.

### Performance Specification

The manufacturer shall provide published performance data. Data shall be tested in accordance to ANSI/ASHRAE Standard 70-1991.

### Paint Specification

Process shall be anodic electrodeposition using an anodic acrylic paint. Units shall undergo pre-treatment including a pressurized spray stage using an alkaine cleaner and a de-ionized water rinse.

# PCD - Perforated Ceiling Diffusers

## Series 7000 - Model Specification Guide

### Square/Rectangular Perforated Curved Blade Ceiling Diffusers

Model	Available Neck	Module	Air Pattern	Available Finishes	Available Options		
7000-1 Flush Surface Mount	6" thru 18"	12" x 12" 14" x 14" 16" x 16" 18" x 18" 20" x 20" 21" x 21" 24" x 12" 24" x 24" 48" x 24"	<b>Standard</b>	<b>Standard</b>	<b>Square Options</b>		
			4W - 4-way	01 - White	D7	Opposed Blade Damper - Steel	
			<b>Options</b>	<b>Options</b>	D7A	Opposed Blade Damper - Aluminum	
			1W - 1-way	02 - Aluminum	L9	Equalizing Grid	
			2W - 2-way	03 - Black	TR	Square to Round Transition	
			3W - 3-way	22 - Black Back Pan White Face	<b>Round Options</b>		
			2C - 2-way corner	28 - Custom Color	G3	Equalizing Grid	
					BDS	Radial Shutter Damper	
					RSD	Induction Vanes	
					D3	Opposed Blade Damper - Aluminum	
					SD3	Opposed Blade Damper - Steel	

Model	Available Neck	Module	Air Pattern	Available Finishes	Available Options		
7000-6 T-bar Lay-in 7000-7 Concealed Spline 7000-8 Tegular T-bar 7000-9 Donn Finline	6" thru 18"	12" x 12" 24" x 12" 24" x 24" 48" x 12" 48" x 24"	<b>Standard</b>	<b>Standard</b>	<b>Square Options</b>		
			4W - 4-way	01 - White	D7	Opposed Blade Damper - Steel	
			<b>Options</b>	<b>Options</b>	D7A	Opposed Blade Damper - Aluminum	
			1W - 1-way	02 - Aluminum	L9	Equalizing Grid	
			2W - 2-way	03 - Black	TR	Square to Round Transition	
			3W - 3-way	24 - Mill	<b>Round Options</b>		
			2C - 2-way corner	28 - Custom Color	G3	Equalizing Grid	
					BDS	Radial Shutter Damper	
					RSD	Induction Vanes	
					D3	Opposed Blade Damper - Aluminum	
		SD3	Opposed Blade Damper - Steel				

### Return and Exhaust Perforated Diffusers

Model	Available Neck	Module	Available Finishes	Available Options		
7000R-1 Surface Mount	6" thru 18"	12" x 12" 14" x 14" 16" x 16" 18" x 18" 20" x 20" 21" x 21" 24" x 12" 24" x 24" 48" x 24"	<b>Standard</b>	<b>Square Options</b>		
			01 - White	D7	Opposed Blade Damper - Steel	
			<b>Options</b>	D7A	Opposed Blade Damper - Aluminum	
			02 - Aluminum	L9	Equalizing Grid	
			03 - Black	TR	Square to Round Transition	
			22 - Black Back Pan White Face	<b>Round Options</b>		
			28 - Custom Color	G3	Equalizing Grid	
				BDS	Radial Shutter Damper	
				RSD	Induction Vanes	
				D3	Opposed Blade Damper - Aluminum	
				SD3	Opposed Blade Damper - Steel	

Model	Available Neck	Module	Available Finishes	Available Options		
7000R-6 T-bar Lay-in 7000R-7 Concealed Spline 7000R-8 Tegular T-bar 7000R-9 Donn Finline	6" thru 18"	12" x 12" 24" x 12" 24" x 24" 48" x 12" 48" x 24"	<b>Standard</b>	<b>Square Options</b>		
			01 - White	D7	Equalizing Grid - Steel	
			<b>Options</b>	D7A	Equalizing Grid - Aluminum	
			02 - Aluminum	L9	Square to Round Transition	
			03 - Black	TR	Square to Round Transition - Deep	
			22 - Black Back Pan White Face	<b>Round Options</b>		
			28 - Custom Color	G3	Equalizing Grid	
				BDS	Radial Shutter Damper	
				RSD	Induction Vanes	
				D3	Opposed Blade Damper - Aluminum	
	SD3	Opposed Blade Damper - Steel				



# PCD - Perforated Ceiling Diffusers

8/2006

- ➔ Return/Exhaust Perforated Screen ➔ Series PRTB ➔ Aluminum ➔ Non-Ducted
- ➔ Series SPRTB ➔ Steel ➔ Non-Ducted

## Product Details

- ★ The series PRTB and SPRTB are an economical choice for non-duct plenum return applications and is shipped without pattern controllers
- ★ The PRTB is constructed from aluminum for corrosion resistance. The SPRTB is constructed from steel for durability
- ★ Unit can be used in surface mounting applications by adding optional T-bar plaster frame (TBPF)

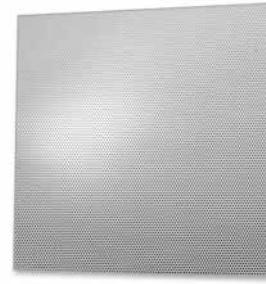

**Model PRTB-6**

Standard Finish: 01 White

Dimensions are in inches

Perforated Ceiling Diffusers



PCD

### Return - Perforated Screen - Non Ducted - T-bar Lay-in

Model PRTB-6 - *Aluminum*  
Model SPRTB-6 - *Steel*

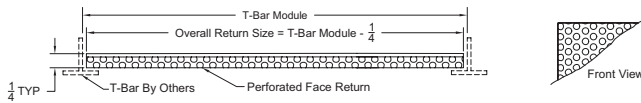

### Return - Perforated Screen - Non Ducted - T-bar Lay-in

Model PRTB-8 - *Aluminum*  
Model SPRTB-8 - *Steel*

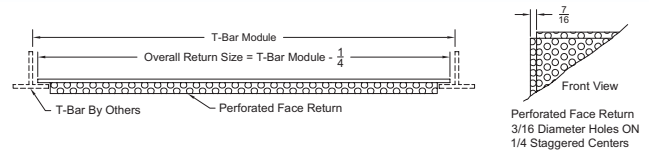

### Return - Perforated Screen - Non Ducted - Donn Finline

Model PRTB-9 - *Aluminum*  
Model SPRTB-9 - *Steel*

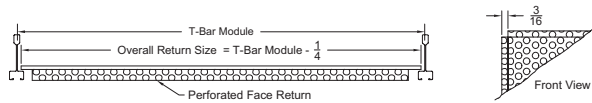

1. Available Finishes	2. Construction Details
<p><b>Standard Finish:</b> 01 White</p> <p><b>Optional Finish</b> 02 Aluminum paint 03 Black 28 Custom color</p>	<ul style="list-style-type: none"> <li>• Available only in sizes listed in Performance Table</li> <li>• PRTB and SPRTB have 3/16" diameters holes on 1/4" staggered centers</li> </ul>

# PCD - Perforated Ceiling Diffusers

## Performance - Series PRTB

Models PRTB (-6, -8, -9), SPRTB (-6, -8, -9)

Nom. Neck Size	fpm Inlet Velocity Negative Ps	200 -.01	300 -.03	400 -.05	500 -.08	600 -.11	700 -.15	800 -.19
12" x 12"	CFM NC	170 <	250 <	335 <	420 20	505 25	590 30	670 35
24" x 12"	CFM NC	350 <	525 <	700 20	875 25	1050 30	1225 35	1400 40
24" x 24"	CFM NC	735 <	1100 <	1470 20	1835 28	2200 33	2570 38	2935 42
36" x 24"	CFM NC	1120 <	1680 <	2235 25	2795 30	3355 35	3915 40	4470 45
48" x 12"	CFM NC	735 <	1100 <	1470 20	1835 28	2200 33	2570 38	2935 42
48" x 24"	CFM NC	1500 <	2250 <	3000 20	3750 28	4500 33	5250 38	6000 42

## Series PRTB - Specification

Return or Exhaust - Perforated Face Only - Non Ducted/Series PRTB

### Aluminum

PRTB-6 - T-bar Lay-in

PRTB-8 - Tegular T-bar

PRTB-9 - Donn Finline

### Steel

SPRTB-6 - T-bar Lay-in

SPRTB-8 - Tegular T-bar

SPRTB-9 - Donn Finline

Air Inlets shall be aluminum model PRTB or steel SPRTB manufactured by METALAIRE. Units shall be designed for use in a non-duct return or exhaust applications. Units shall consist of a 51% free area perforated face. Perforated holes shall be 3/16" diameter on 1/4" staggered centers.

The units shall be the size and quantity as outline in the plans and specifications.

Units shall be designed to integrate into the specified ceiling system.

## Performance Specification

The manufacturer shall provide published performance data. Data shall be tested in accordance to ANSI/ASHRAE Standard 70-1991.

## Paint Specification

Process shall be anodic electrodeposition using an anodic acrylic paint. Units shall undergo pre-treatment including a pressurized spray stage using an alkaine cleaner and a de-ionized water rinse.

## Series PRTB - Model Specification Guide

Return and Exhaust - Perforated Screen - Non Ducted

Series PRTB

Steel - Perforated Face

Model	Module	Available Finishes
SPRTB-6 T-bar Lay-in SPRTB-8 Tegular T-bar SPRTB-9 Donn Finline	12" x 12"	Standard
		01 - White
	24" x 12" 24" x 24" 36" x 24" 48" x 12" 48" x 24"	Options
		02 - Aluminum
		03 - Black
		24 - Mill
		28 - Custom Color

Aluminum - Perforated Face

Model	Module	Available Finishes
PRTB-6 T-bar Lay-in PRTB-8 Tegular T-bar PRTB-9 Donn Finline	12" x 12"	Standard
		01 - White
	24" x 12" 24" x 24" 36" x 24" 48" x 12" 48" x 16" 48" x 24"	Options
		02 - Aluminum
		03 - Black
		24 - Mill
		28 - Custom Color



# PCD - Perforated Ceiling Diffusers

8/2006

- ➔ Perforated Supply Diffuser ➔ Series 7300 ➔ Steel Face
- ➔ Series 7300-AF ➔ Aluminum Face

## Product Details

- ★ The series 7300 perforated supply diffuser is an economical diffuser with a fiberglass plenum designed to allow field installation of the inlet collar (by others). The face of the diffuser is non-removable and includes a pattern controller set for a circular 360° degree round discharge pattern
- ★ The series 7300 provides a 360° tight horizontal circular pattern along the ceiling
- ★ The series 7300 includes a T-bar Lay-in border type 6 which is designed to be installed in standard 15/16" tee
- ★ Border type 6 can be used in surface mounting applications by adding optional T-bar plaster frame(TBPF)
- ★ Matching returns available: 7300R
- ★ The series 7300 is an excellent choice for VAV applications



**Model 7300-6**  
Standard Finish: 01 White

Dimensions are in inches

### Perforated Supply Diffusers - Foil Lined Fiberglass Back - T-bar Lay-in

Model 7300-6 - Steel fixed face  
Model 7300-6 AF - Aluminum fixed face

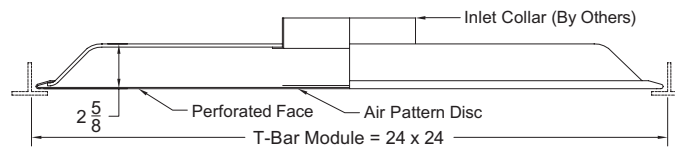

1. Available Finishes	2. Construction Details
<p><b>Standard Finish:</b> 01 White with black dispersion disc and plenum interior</p>	<ul style="list-style-type: none"> <li>• Neck is pre-scored to 5", 6", 7", 8", 10", 12", 14" &amp; 15"</li> <li>• Face is non-removable</li> <li>• Inlet collars are provided by others</li> <li>• 7300 series has 3/16" diameter holes on 1/4" staggered centers</li> </ul>

Perforated Ceiling Diffusers



PCD

# PCD - Perforated Ceiling Diffusers

## Series 7300 - Performance

### Models 7300-6, 7300-6 AF

Neck Size	fpm Neck Velocity Pv	200 .002	300 .006	400 .010	500 .016	600 .022	700 .030	800 .040	900 .050	1000 .062
5"	CFM	25	40	55	70	80	95	110	120	138
	Pt	.003	.008	.016	.025	.033	.045	.060	.076	.094
	Throw	1-1-1	1-1-1	1-1-1	1-1-3	1-1-4	1-1-4	1-1-5	1-2-6	1-3-6
	NC	<	<	<	<	<	<	21	24	27
6"	CFM	40	60	80	100	115	135	155	175	196
	Pt	.004	.009	.016	.027	.035	.049	.066	.078	.105
	Throw	1-1-1	1-1-1	1-1-4	1-2-4	1-2-5	1-3-6	2-3-7	2-3-8	2-4-10
	NC	<	<	<	<	22	26	30	35	38
7"	CFM	50	80	105	135	160	185	210	240	265
	Pt	.005	.013	.026	.036	.050	.068	.088	.115	.140
	Throw	1-1-1	1-1-3	1-1-4	1-2-4	1-2-5	1-3-6	2-3-7	2-3-8	2-4-10
	NC	<	<	<	20	23	26	30	34	37
8"	CFM	70	105	140	175	210	245	280	315	350
	Pt	.006	.013	.026	.037	.054	.073	.096	.121	.150
	Throw	1-1-2	1-1-3	1-2-5	2-2-5	2-3-6	2-3-8	2-4-10	3-5-11	3-6-12
	NC	<	<	<	20	23	26	30	34	38
9"	CFM	90	130	175	220	265	310	350	395	440
	Pt	.007	.014	.026	.042	.060	.083	.105	.134	.166
	Throw	1-1-2	1-1-3	1-2-5	2-2-5	2-3-6	2-3-8	2-4-10	3-5-11	3-6-13
	NC	-	-	-	22	26	30	34	38	41
10"	CFM	110	160	215	270	325	380	435	490	545
	Pt	.008	.018	.033	.052	.075	.111	.135	.171	.212
	Throw	1-2-3	1-2-4	1-2-5	2-3-6	2-3-7	3-4-8	3-4-10	3-5-12	4-7-14
	NC	<	<	20	23	26	29	34	38	41
12"	CFM	155	235	315	390	470	550	630	705	785
	Pt	.009	.021	.039	.059	.086	.118	.155	.194	.240
	Throw	1-2-4	1-2-5	1-2-7	2-3-9	2-5-11	3-6-13	4-7-14	6-9-18	7-11-21
	NC	<	20	24	27	30	34	38	42	45
14"	CFM	210	320	425	535	640	750	855	960	1070
	Pt	.010	.022	.039	.063	.091	.124	.162	.210	.253
	Throw	1-2-6	1-3-9	2-5-11	3-6-13	4-8-16	5-9-18	7-11-23	9-13-27	10-16-32
	NC	<	20	24	28	32	36	40	45	48
15"	CFM	245	370	490	610	735	860	980	1105	1225
	Pt	.015	.034	.060	.093	.135	.185	.240	.305	.375
	Throw	1-3-9	2-5-11	3-6-13	4-8-16	5-10-18	7-11-23	9-13-27	10-16-32	11-16-33
	NC	<	23	28	33	38	43	48	53	55

**Series 7300 - Performance Notes:**  
All data are tested in accordance with ANSI/ASHRAE 70-1991

#### Definition of Units:

**CFM** - Cubic Feet per Minute (air)

**fpm** - Velocity of air stream in Feet Per Minute

**Pv** - Velocity pressure (inches of water column)

**Pt** - Total pressure (inches of water column)

**Ps** - Static pressure = Pt - Pv (inches of water column)

**Throw** - Cataloged throw is horizontal distances in feet to the terminal velocities of 150, 100 and 50 fpm with supply air temperature 20° F below room air temperature

**NC** - Noise criterion, sound pressure level. NC ratings are based on sound power level (Lw) RE: 10E-12 watts minus a 10 dB room attenuation in all octave bands

## Series 7300 - Specification

### Supply - Perforated Face - Intergral Fiberglass Backpan - Fixed Deflector

#### Fixed Steel Face

7300-6 - Surface Mounted

#### Fixed Aluminum Face

7300-6 AF - Surface Mounted

Air Outlets shall be aluminum face model 7300 or steel face model 7300 AF manufactured by METALAIRE. Units shall consist of 51% free area perforated face fixed to a formed fiberglass backpan. Exposed fiberglass backpan shall have an aluminum foil liner. The outlet's backpan shall be factory scored to allow field installation of a tab lock collar or spin-in fittings.

Perforated holes shall be 3/16" diameter on 1/4" staggered centers.

Unit shall generate a 360° horizontal pattern with a fixed round pattern disk mounted on the inside face of the perforated face.

The units shall be the size and quantity as outline in the plans and specifications.

Units shall be designed to integrate into the specified ceiling system.

### Performance Specification

The manufacturer shall provide published performance data. Data shall be tested in accordance to ANSI/ASHRAE Standard 70-1991.

### Paint Specification

Process shall be anodic electrodeposition using an anodic acrylic paint. Units shall undergo pre-treatment including a pressurized spray stage using an alkaline cleaner and a de-ionized water rinse.

## Series 7300 - Model Specification Guide

### Perforated Supply Diffusers - Foil Lined Fiberglass Back Steel Face - Series 7300

Model	Module	Finishes
7300-6 - T-bar Lay-in	24" x 24"	Standard
7300-6 AF - T-bar Lay-in - Aluminum Face		
		01 - White





# PCD - Perforated Ceiling Diffusers

8/2006

- ➔ Perforated Supply/Return Diffuser ➔ Series 7350 ➔ Steel Face
- ➔ Series 7350 AF ➔ Aluminum Face

## Product Details

- ★ The series 7350 perforated supply diffuser is an economical diffuser with a fiberglass plenum designed to allow field installation of the inlet collar (by others)
- ★ The face diffuser includes a hinged removable face and 4 pattern controllers that can be adjusted for a 1-way, 2-way opposite, 2-way corner, 3-way, and 4-way discharge air patterns
- ★ Set in a 4-way pattern, the 7350 provides a 360° tight horizontal circular pattern along the ceiling
- ★ Border type 6 can be used in surface mounting applications by adding optional T-bar Plaster Frame (TBPf)
- ★ Matching returns available: 7350R
- ★ The series 7350 is an excellent choice for VAV applications



**Model 7350-1**  
Standard Finish: 01 White

Dimensions are in inches

### Perforated Supply Diffusers - Foil Lined Fiberglass Back T-bar Lay-in

- Model 7350-6 - Steel fixed face
- Model 7350-6 AF - Aluminum fixed face

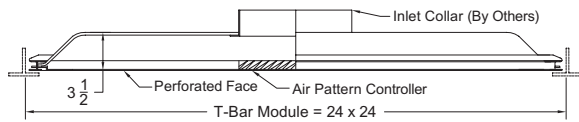

### Perforated Supply Diffusers - Foil Lined Fiberglass Back Tegular T-bar - Steel

- Model 7350-8 - Hinged drop face

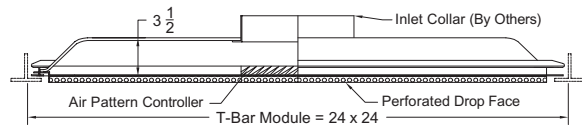

1. Available Finishes	2. Available Options
<p>Standard Finish: 01 White</p>	<ul style="list-style-type: none"> <li>• Neck is pre-scored to 5", 6", 7", 8", 10", 12", 14" &amp; 15"</li> <li>• Return diffusers have no pattern controllers</li> <li>• Faces are hinged and removable</li> <li>• Models: 7350-6, 7350-6 AF &amp; 7350-8 include 4 black painted, individually adjusted pattern controllers, mounted on rear of the perforated face</li> <li>• 7350 series has 3/16" diameter holes on 1/4" centers</li> </ul>

### Series 7350 - Performance Notes:

All data are tested in accordance with ANSI/ASHRAE 70-1991

### Definition of Units:

- CFM** - Cubic Feet per Minute (air)
- fpm** - Velocity of air stream in Feet Per Minute
- Pv** - Velocity pressure (inches of water column)
- Pt** - Total pressure (inches of water column)
- Ps** - Static pressure = Pt - Pv (inches of water column)
- Throw** - Cataloged throw is horizontal distances in feet to the terminal velocities of 150, 100 and 50 fpm with supply air temperature 20° F below room air temperature
- NC** - Noise criterion, sound pressure level. NC ratings are based on sound power level (Lw) RE: 10E-12 watts minus a 10 dB room attenuation in all octave bands

Perforated Ceiling Diffusers



PCD



# PCD - Perforated Ceiling Diffusers

## Series 7350-6 Performance

### Models 7350-6, 7350-6 AF

Neck Size	fpm Neck Velocity Pv	300 .006	400 .010	500 .016	600 .023	700 .031	800 .040	1000 .062	
6"	CFM	60	80	100	115	135	155	195	
	Pt	.012	.022	.034	.045	.062	.083	.131	
	NC	<	<	<	-	20	24	31	
	Throw	4-Way	1-1-3	1-1-4	1-2-4	1-2-5	1-3-6	2-3-7	2-3-8
		3-Way	1-1-3	1-2-4	2-2-5	2-3-6	2-3-6	2-3-8	2-4-8
2-Way		1-2-4	1-2-5	2-3-5	2-4-6	3-4-7	3-4-9	3-4-9	
1-Way		1-2-5	1-3-5	3-4-6	3-4-7	3-4-8	3-5-9	3-5-10	
8"	CFM	105	140	175	210	245	280	350	
	Pt	.017	.031	.048	.070	.095	.124	.195	
	NC	<	<	<	21	26	30	36	
	Throw	4-Way	1-1-3	1-2-5	2-2-5	2-3-6	2-3-8	2-4-10	3-5-11
		3-Way	1-2-3	1-2-5	2-3-5	2-3-6	3-3-8	3-4-11	3-5-12
2-Way		1-2-4	2-4-5	2-4-6	3-4-7	3-4-9	3-5-12	4-6-13	
1-Way		2-3-5	2-4-5	3-4-7	3-5-8	3-5-10	3-6-13	4-6-14	
10"	CFM	165	220	270	325	380	435	545	
	Pt	.020	.035	.053	.077	.106	.138	.218	
	NC	<	<	22	28	33	37	43	
	Throw	4-Way	1-2-4	1-2-5	2-3-6	2-3-7	3-4-8	3-4-10	3-5-12
		3-Way	1-2-4	1-3-6	2-3-7	2-4-8	3-5-9	3-5-12	3-6-13
2-Way		1-2-5	2-3-6	3-4-8	3-4-8	3-6-10	3-6-14	4-7-15	
1-Way		2-3-6	2-4-7	3-5-9	3-5-10	4-7-11	4-7-14	5-9-16	
12"	CFM	235	315	390	470	550	630	785	
	Pt	.032	.059	.090	.131	.180	.236	.367	
	NC	<	<	25	29	35	40	46	
	Throw	4-Way	1-2-4	2-2-8	3-3-8	3-5-10	3-5-11	4-6-12	5-7-14
		3-Way	2-3-5	2-3-8	3-4-9	3-5-11	4-6-13	4-7-14	5-8-15
2-Way		2-3-6	3-4-8	3-5-11	3-6-12	4-7-13	5-8-15	6-9-16	
1-Way		3-4-8	3-5-9	4-6-12	4-7-13	5-8-14	6-9-16	7-10-18	
14"	CFM	320	425	535	640	750	855	1070	
	Pt	.039	.068	.108	.156	.213	.277	.435	
	NC	<	23	29	34	39	44	50	
	Throw	4-Way	2-3-6	3-4-8	3-5-11	4-6-13	4-7-14	5-8-15	6-9-17
		3-Way	2-4-7	3-5-9	3-6-12	4-7-14	5-8-16	5-9-17	6-10-18
2-Way		2-5-8	3-5-10	3-7-13	5-8-15	6-10-17	7-10-18	8-11-19	
1-Way		3-5-9	4-8-11	4-8-14	6-9-16	7-11-18	8-12-19	9-12-20	

See Page PCD-116 for Series 7350-8 Performance Notes

## Series 7350-8 Performance

### Models 7350-8

Neck Size	fpm Neck Velocity Pv	300 .006	400 .010	500 .016	600 .023	700 .031	800 .040	1000 .062	
6"	CFM	60	80	100	115	135	155	195	
	Pt	.010	.017	.027	.036	.049	.065	.103	
	NC	<	<	<	<	20	23	29	
	Throw	4-Way	1-1-3	1-1-4	1-2-5	1-2-6	1-4-7	2-4-8	3-4-8
		3-Way	1-1-3	1-1-4	2-3-6	2-3-6	2-3-7	3-3-9	4-4-9
2-Way		1-2-4	1-2-5	2-3-7	2-4-9	3-4-10	3-3-10	3-4-10	
1-Way		1-2-5	1-3-6	3-4-7	3-4-9	4-4-11	4-4-11	4-4-12	
8"	CFM	105	140	175	210	245	280	350	
	Pt	.014	.026	.040	.058	.078	.120	.160	
	NC	<	<	<	20	25	28	33	
	Throw	4-Way	1-1-4	1-2-6	2-3-5	2-4-6	3-4-8	3-5-10	4-5-11
		3-Way	1-2-4	1-2-6	2-3-6	2-4-7	4-3-8	4-4-11	4-4-12
2-Way		1-3-4	1-3-6	2-4-8	3-4-9	3-4-10	3-5-12	4-5-13	
1-Way		2-3-6	3-4-7	4-4-9	4-5-10	4-5-11	4-5-12	5-5-12	
10"	CFM	165	220	270	325	380	435	545	
	Pt	.016	.029	.044	.064	.087	.114	.179	
	NC	<	<	21	27	32	34	40	
	Throw	4-Way	1-1-5	1-4-6	3-4-6	3-4-8	4-2-9	5-5-11	5-5-14
		3-Way	1-3-5	2-4-6	3-4-8	4-4-8	4-5-9	5-5-12	5-7-14
2-Way		1-3-5	2-3-6	4-5-8	4-5-9	4-6-11	5-6-14	5-6-15	
1-Way		3-4-6	3-4-7	5-5-9	5-5-10	5-7-12	6-7-15	6-9-17	
12"	CFM	235	315	390	470	550	630	785	
	Pt	.028	.051	.078	.113	.155	.203	.316	
	NC	<	<	24	28	34	37	44	
	Throw	4-Way	1-4-5	3-4-9	5-5-10	5-6-11	5-6-11	6-8-12	6-9-15
		3-Way	3-4-6	3-4-9	5-5-10	5-6-11	5-7-11	5-8-13	6-9-16
2-Way		3-5-6	4-5-9	5-5-11	5-6-12	5-7-12	6-8-14	6-9-17	
1-Way		4-5-10	5-7-12	6-8-15	6-9-13	6-10-14	7-12-16	9-13-19	
14"	CFM	320	425	535	640	750	855	1070	
	Pt	.034	.059	.094	.134	.185	.240	.376	
	NC	<	23	29	33	36	40	47	
	Throw	4-Way	2-5-7	4-6-10	5-7-13	6-7-14	6-8-14	7-10-15	7-11-18
		3-Way	3-6-8	4-6-10	5-7-13	6-8-15	6-9-16	7-11-18	7-11-19
2-Way		3-6-8	4-6-10	5-7-13	6-8-16	6-10-17	8-11-19	8-12-19	
1-Way		4-6-11	6-10-14	6-10-15	8-11-17	9-13-18	9-15-19	11-15-21	

Perforated Ceiling Diffusers



PCD

## Series 7350 - Specification

### Supply - Perforated Face - Fiberglass Backpan - Adjustable Pattern Controllers/Series 7350

#### Steel Face

7350-6 - T-bar Lay-in  
7350-8 - Tegular T-bar

#### Aluminum Face

7350-6 AF - T-bar Lay-in

Air Outlets shall be aluminum face model 7350 or steel face model 7350 AF manufactured by METALAIR. Units shall consist of 51% free area perforated face fixed to a formed fiberglass backpan. Perforated holes shall be 3/16" diameter on 1/4" staggered centers. Exposed fiberglass backpan shall have an aluminum foil liner. The outlet's backpan shall be factory scored to allow field installation of a tab lock collar or spin-in fittings

Outer border of units shall be extruded aluminum construction. The perforated face shall be hinged allowing access to four adjustable pattern controllers mounted onto the inside face of the outlet. Face shall be secured in place with tension spring clips. Pattern controller blades shall be individually adjustable and allow the discharge pattern to be adjustable from vertical to horizontal.

Outlets shall be field adjustable allowing 1, 2-way opposite, 2-way corner, 3, and 4-way directional air patterns.

The units shall be the size and quantity as outline in the plans and specifications.

Units shall be designed to integrate into the specified ceiling system.

### Performance Specification

The manufacturer shall provide published performance data. Data shall be tested in accordance to ANSI/ASHRAE Standard 70-1991.

## Series 7350 - Model Specification Guide

### Supply - Perforated Diffusers - Hinged Face - Foil Lined Fiberglass Back

#### Series 7350

Model	Module	Finishes
7350-6 - T-bar Lay-in - Steel Face	24" x 24"	Standard
7350-8 - Tegular T-bar - Steel Face		01 - White
7350-6 AF - T-bar Lay-in - Aluminum Face		

#### Series 7350R

Model	Module	Finishes
7350R-6 - T-bar Lay-in - Steel Face	24" x 24"	Standard
7350R-8 - Tegular T-bar - Steel Face		01 - White
7350R-6 AF - T-bar Lay-in - Aluminum Face		

# PCD - Perforated Ceiling Diffusers

8/2006

- ➔ Supply/Return Perforated Ceiling Diffusers ➔ Round Neck
- ➔ Face Mounted Adjustable Pattern Controllers

## Product Details

- ★ Series 7500 perforated supply diffusers have 4 adjustable pattern controllers mounted on the face of the diffuser.
- ★ Series 7500 are round neck diffusers
- ★ The hinged, fully removable face allows access to the pattern controllers
- ★ Unit can be adjusted for 1-way, 2-way opposite, 2-way corner, 3-way, and 4-way patterns. In 4-way pattern, Series 7500 provides a 360° tight horizontal circular pattern along the ceiling
- ★ Border type 6 can be used in surface mounting applications by adding optional T-bar plaster frame (TBPF)
- ★ Matching returns available: 7500R (round neck) and 7550R (square neck)
- ★ The series 7500 is an excellent choices for VAV applications
- ★ Also available in square neck series 7550

Series 7500	
7500	Steel Backpan & Face
7500 AF	Steel Backpan & Aluminum Face
7500 AL	Aluminum Backpan & Face

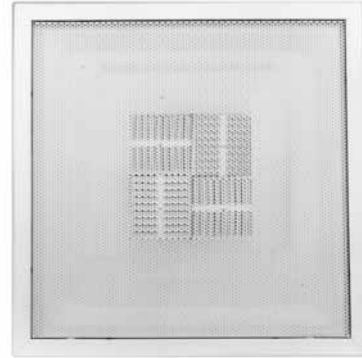

**Model 7500-1**  
Standard Finish: 01 White

Perforated Ceiling Diffusers



PCD

## Supply

Dimensions are in inches

### Supply - Round Neck - Adjustable - Surface Mount - 24" x 24"

Model 7500-1 - Steel backpan & face  
 Model 7500-1 AF - Steel backpan & aluminum face  
 Model 7500-1 DF - Steel backpan & face - drop face

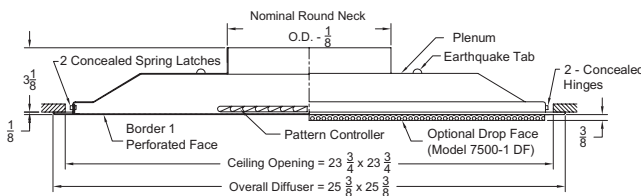

### Supply - Round Neck - Adjustable - Surface Mount - 12" x 12"

Model 7500-1 - Steel backpan & face  
 Model 7500-1 AF - Steel backpan & aluminum face  
 Model 7500-1 DF - Steel backpan & face - drop face

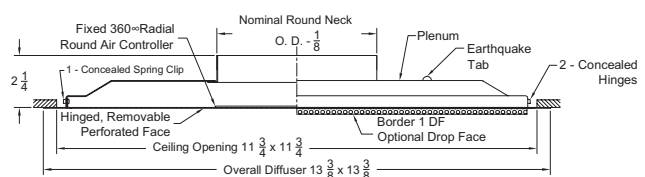

### Supply - Round Neck - Adjustable - T-bar Lay-in - 24" x 24"

Model 7500-6 - Steel backpan & face  
 Model 7500-6 AF - Steel backpan & aluminum face  
 Model 7500-6 AL - Aluminum backpan & face

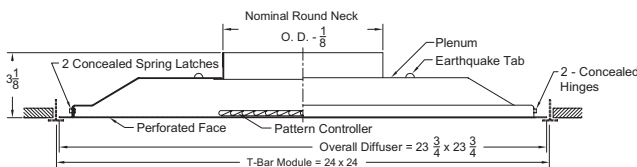

### Supply - Round Neck - Adjustable - T-bar Lay-in - 12" x 12"

Model 7500-6 - Steel backpan & face  
 Model 7500-6 AF - Steel backpan & aluminum face  
 Model 7500-6 AL - Aluminum backpan & face

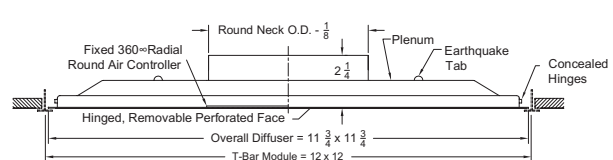

# PCD - Perforated Ceiling Diffusers



## Supply - Round Neck - Adjustable - Tegular T-bar - 24" x 24"

Model 7500-8 - Steel backpan & face  
 Model 7500-8 AF - Steel backpan & aluminum face  
 Model 7500-8 AL - Aluminum backpan & face

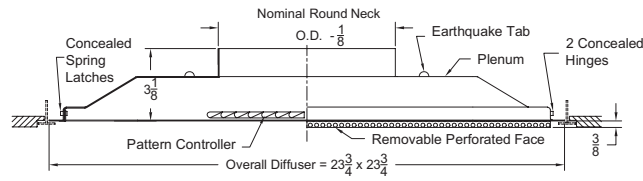

## Supply - Round Neck - Adjustable - Tegular T-bar - 12" x 12"

Model 7500-8 - Steel backpan & face  
 Model 7500-8 AF - Steel backpan & aluminum face

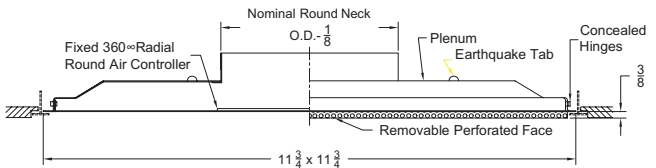

## Supply - Round Neck - Adjustable - Donn Finline - 24" x 24"

Model 7500-9 - Steel backpan & face  
 Model 7500-9 AF - Steel backpan & aluminum face

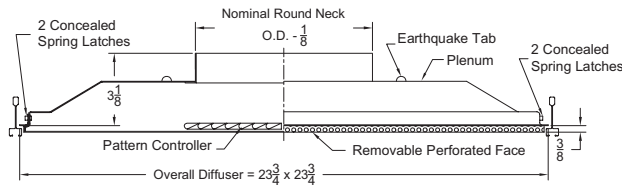

## Return

### Return - Round Neck - Surface Mount - 24" x 24"

Model 7500R-1 - Steel backpan & face  
 Model 7500R-1 AF - Steel backpan & aluminum face  
 Model 7500R-1 DF - Steel backpan & face - drop face

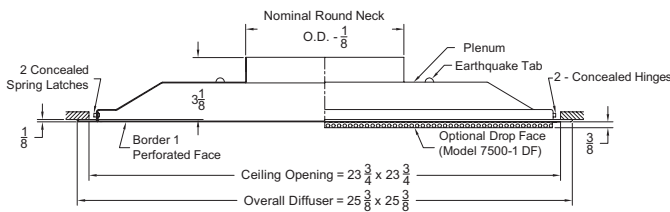

### Return - Round Neck - Surface Mount - 12" x 12"

Model 7500R-1 - Steel backpan & face  
 Model 7500R-1 AF - Steel backpan & aluminum face  
 Model 7500R-1 DF - Steel backpan & face - drop face

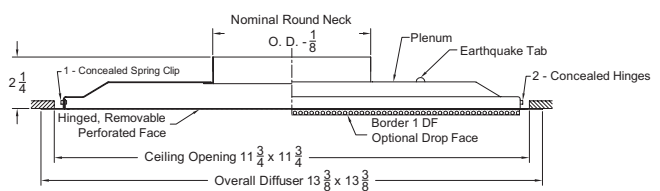

### Return - Round Neck - T-bar Lay-in - 24" x 24"

Model 7500R-6 - Steel backpan & face  
 Model 7500R-6 AF - Steel backpan & aluminum face  
 Model 7500R-6 AL - Aluminum backpan & face

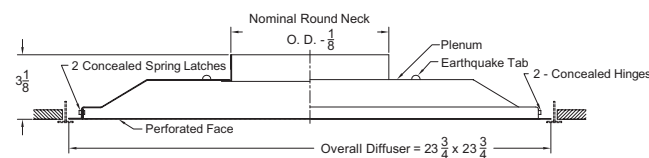

### Return - Round Neck - Face Mounted - T-bar Lay-in - 12" x 12"

Model 7500R-6 - Steel backpan & face  
 Model 7500R-6 AF - Steel backpan & aluminum face  
 Model 7500R-6 AL - Aluminum backpan & face

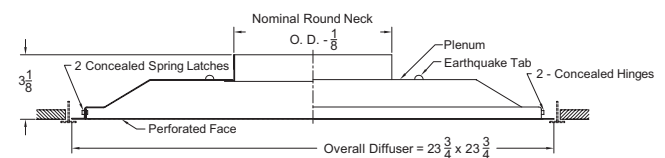

# PCD - Perforated Ceiling Diffusers

8/2006

Perforated Ceiling Diffusers



PCD

**Return - Round Neck - Face Mounted - T-bar Lay-in - 24" x 24"**  
 Model 7500R-8 - Steel backpan & face  
 Model 7500R-8 AF - Steel backpan & aluminum face  
 Model 7500R-8 AL - Aluminum backpan & face

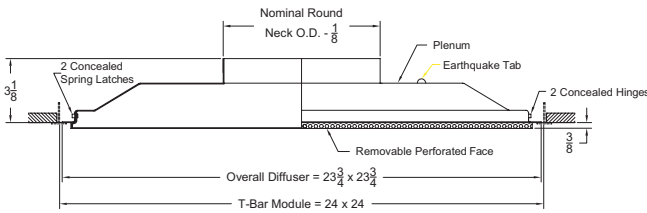

**Return - Round Neck - Face Mounted - T-bar Lay-in - 12" x 12"**  
 Model 7500R-8 - Steel backpan & face  
 Model 7500R-8 AF - Steel backpan & aluminum face  
 Model 7500R-8 AL - Aluminum backpan & face

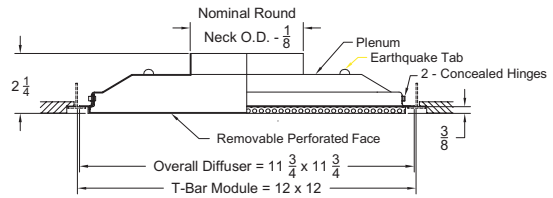

**Return - Round Neck - Face Mounted - Donn Finline - 24" x 24"**  
 Model 7500R-9 - Steel backpan & face  
 Model 7500R-9 AF - Steel backpan & aluminum face

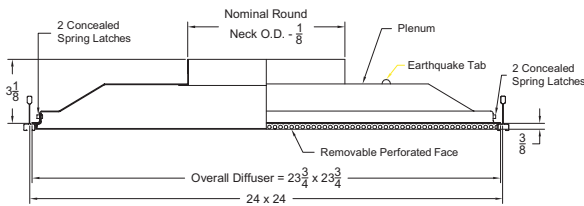

**Return - Round Neck - Face Mounted - Donn Finline - 24" x 24"**  
 Model 7500R-9 - Steel backpan & face  
 Model 7500R-9 AF - Steel backpan & aluminum face

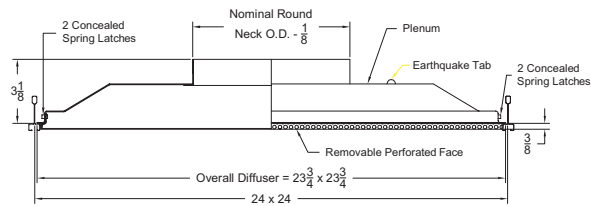

## Metric

Dimensions are in millimeters

**Supply - Round Neck - T-bar Lay-in**  
 Model M7500-6

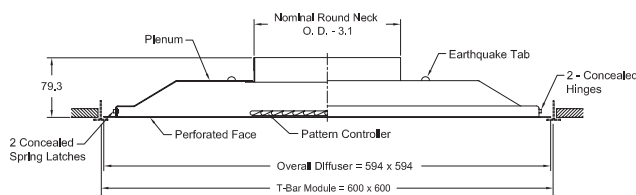

**Return - Round Neck - T-bar Lay-in**  
 Model M7500R-6

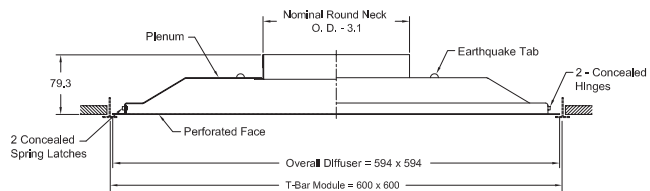

### Notes for Models 7500 (-1, -6, -8, -9) 7500-1 DF, 7500 AF (-1, -6, -8), 7500 AL (-6, -8)

1. Available Finishes	2. Available Accessories	3. Construction Details
<p><b>Standard Finish:</b>                      01 White (border only for 7500-1)</p> <p><b>Optional Finish</b>                      02 Aluminum paint                      03 Black                      22 (BBP) Black back pan/white face &amp; border                      28 Custom color</p>	<p>All accessories shipped unattached</p> <p><b>Round Neck:</b>                      G3 - Equalizing grid ..... 337                      BDS - Butterfly damper ..... 335                      RSD - Radial Shutter damper ..... 336</p>	<ul style="list-style-type: none"> <li>Available only in listed sizes</li> <li>Pattern controllers are mounted on the back side of the perforated face and can be adjusted to 1, 2, 3 or 4 way pattern</li> <li>Seismic tabs standard on all units</li> <li>Pattern controller on 12" x 12" unit is a non adjustable disc on the perforated face</li> <li>7500 series have 3/16" diameter holes on 1/4" staggered centers</li> </ul>

### Notes for Models 7500R (-1, -6, -8, -9) 7500R-1 DF, 7500R AF (-1, -6, -8, -9) 7500R AL (-6, -8)

1. Available Finishes	2. Available Accessories	3. Construction Details
<p><b>Standard Finish:</b>                      01 White</p> <p><b>Optional Finish</b>                      02 Aluminum paint                      03 Black                      22 (BBP) Black back pan/white face &amp; border and white border (for 7500R-1 models only)                      28 Custom color</p>	<p>All accessories shipped unattached</p> <p><b>Square Necks:</b>                      OBD - Opposed blade damper - Steel ..... 334                      OBDA - Opposed blade damper - Aluminum . . . 334</p> <p><b>Round Neck:</b>                      BDS - Butterfly damper ..... 335                      RSD - Radial Shutter damper ..... 336</p>	<ul style="list-style-type: none"> <li>Available only in listed sizes</li> <li>7500R series have 3/16" diameter holes on 1/4" staggered centers</li> </ul>

# PCD - Perforated Ceiling Diffusers

## Series 7500 - Performance/Flush Face - Round Neck

Models 7500 (-1, -6), 7500 AF (-1, -6), 7500 AL (-6)

Listed Size	Neck Size	fpm Neck Velocity Pv	300 0.006	400 0.010	500 0.016	600 0.022	700 0.031	800 0.040	1000 0.062	1200 0.090
12" x 12"	6"	CFM Pt	60 0.011	80 0.019	100 0.030	120 0.043	135 0.054	155 0.072	195 0.114	235 0.165
		Throw	4*-Way	1-2-3	1-2-5	2-3-5	2-3-6	3-4-6	3-4-6	4-5-7
	4-Way		1-2-4	1-2-5	2-3-6	2-4-6	3-4-7	3-5-7	4-6-8	5-6-9
	3-Way		1-2-4	1-3-5	2-3-6	3-4-6	3-5-7	4-5-7	4-6-8	5-6-9
	2-Way		1-2-5	2-3-5	3-4-6	3-5-6	4-5-7	4-5-7	5-6-8	5-6-9
	1-Way		1-2-5	2-3-5	3-4-6	3-5-7	4-5-7	4-5-8	5-6-8	5-7-9
	NC	-	-	<15	17	21	25	31	36	
	8"	CFM Pt	105 0.015	140 0.027	175 0.043	210 0.061	245 0.083	280 0.109	350 0.170	420 0.245
		Throw	4*-Way	1-2-5	2-3-6	3-4-7	3-5-7	4-5-8	4-6-9	5-7-10
	4-Way		1-2-5	2-3-6	3-4-7	3-5-8	4-6-9	4-6-9	5-7-11	6-8-12
3-Way	1-2-5		2-4-7	3-5-8	4-5-8	4-6-9	5-7-10	6-8-11	7-8-12	
2-Way	2-3-6		3-4-7	4-5-8	4-6-9	5-7-9	6-7-10	6-8-11	7-9-12	
1-Way	2-3-6		3-4-7	4-5-8	4-6-9	5-7-9	6-7-10	7-8-11	7-9-12	
NC	-	-	<15	20	25	30	37	43		
24" x 24"	6"	CFM Pt	60 0.010	80 0.019	100 0.029	120 0.042	135 0.053	155 0.070	195 0.110	235 0.160
		Throw	4*-Way	1-2-4	1-2-5	2-3-5	2-4-6	3-4-6	3-5-7	4-5-8
	4-Way		1-2-4	1-3-5	2-3-6	3-4-7	3-4-7	3-5-7	4-6-8	5-6-9
	3-Way		1-2-4	1-3-5	2-4-6	3-4-7	3-5-7	4-5-8	5-6-8	5-7-9
	2-Way		1-3-5	2-3-6	3-4-6	3-5-7	4-5-7	4-5-8	5-6-9	5-7-9
	1-Way		1-3-5	2-3-6	3-4-6	3-5-7	4-5-7	4-6-8	5-6-9	6-7-10
	NC	-	-	<15	17	21	25	31	36	
	8"	CFM Pt	105 0.016	140 0.028	175 0.043	210 0.063	245 0.085	280 0.111	350 0.174	420 0.250
		Throw	4*-Way	1-2-5	2-3-6	3-4-7	3-5-8	4-6-9	4-6-9	5-7-10
	4-Way		1-2-5	2-3-7	3-4-8	3-5-9	4-6-9	4-7-10	6-8-11	7-9-12
	3-Way		1-2-6	2-4-7	3-5-8	4-6-9	4-7-10	5-7-10	6-8-11	7-9-12
	2-Way		2-3-6	3-5-7	4-6-8	5-6-9	5-7-10	6-7-10	7-8-12	7-9-13
	1-Way		2-3-7	3-5-8	4-6-8	5-7-9	5-7-10	6-8-11	7-8-12	8-9-13
	NC	-	-	<15	20	25	30	37	43	
	10"	CFM Pt	165 0.023	220 0.041	275 0.064	325 0.090	380 0.123	435 0.161	545 0.252	655 0.365
		Throw	4*-Way	1-3-6	2-4-8	3-5-9	4-6-10	5-7-11	5-8-11	7-9-13
	4-Way		1-3-6	2-4-8	3-5-10	4-6-11	5-7-12	5-8-12	7-10-14	8-11-15
	3-Way		1-3-7	2-5-9	3-6-10	4-7-11	5-8-12	6-9-13	8-10-14	9-11-16
	2-Way		2-4-8	4-6-9	5-7-10	6-8-11	7-9-12	7-9-13	8-10-14	9-11-16
	1-Way		2-4-8	4-6-9	5-7-11	6-8-11	7-9-12	7-9-13	9-11-15	9-12-16
NC	-	<15	15	22	28	33	42	48		
12"	CFM Pt	235 0.025	315 0.044	395 0.070	470 0.099	550 0.135	630 0.177	785 0.275	940 0.395	
	Throw	4*-Way	1-3-7	3-5-10	4-6-11	5-7-12	6-8-13	6-10-14	8-11-15	10-12-17
4-Way		1-3-7	3-5-10	4-6-12	5-7-13	6-9-14	7-10-15	8-12-17	10-13-18	
3-Way		1-3-8	3-6-11	4-7-12	6-8-13	7-10-14	8-11-15	9-12-17	11-13-19	
2-Way		3-5-9	5-7-11	6-8-12	7-9-13	8-10-15	9-11-16	10-12-17	11-13-19	
1-Way		3-5-10	5-7-11	6-8-13	7-10-14	8-11-15	9-11-16	10-13-18	11-14-20	
NC	-	<15	17	24	31	37	45	52		
14"	CFM Pt	320 0.033	430 0.059	535 0.091	640 0.131	750 0.179	855 0.233	1070 0.365	1285 0.527	
	Throw	4*-Way	2-4-8	3-6-11	5-7-13	6-8-14	7-10-15	7-11-16	9-13-18	11-14-20
4-Way		2-4-9	3-6-12	5-7-14	6-9-15	7-10-16	8-12-17	10-14-19	12-15-21	
3-Way		2-4-10	3-7-13	5-8-14	7-10-15	8-12-17	9-13-18	11-14-20	13-15-22	
2-Way		3-6-11	5-8-13	7-10-14	8-11-16	9-12-17	10-13-18	12-14-20	13-16-22	
1-Way		3-6-11	5-8-13	7-10-15	8-11-16	9-12-17	10-13-19	12-15-21	13-16-23	
NC	-	<15	18	27	34	41	50	56		
16"	CFM Pt	420 0.040	560 0.071	700 0.110	840 0.159	975 0.214	1115 0.280	1395 0.438	1675 0.631	
	Throw	4*-Way	2-4-10	4-6-13	5-8-14	6-10-16	7-11-17	8-13-18	11-14-20	13-16-22
4-Way		2-4-10	3-7-13	5-8-16	7-10-17	8-12-19	9-13-20	11-16-22	13-17-24	
3-Way		2-4-11	3-8-14	5-9-16	8-11-18	9-13-19	10-14-20	13-16-23	14-18-25	
2-Way		4-7-13	6-9-15	8-11-16	9-13-18	10-14-19	12-15-21	13-16-23	15-18-25	
1-Way		4-7-13	6-9-15	8-11-17	9-13-18	10-14-20	12-15-21	14-17-24	15-18-26	
NC	-	<15	20	29	36	43	52	60		

See Page PCD-123 for Series 7500 Performance Notes

Perforated Ceiling Diffusers



PCD



## Series 7500R - Performance

Models 7500R (-1, -6, -8, -9), 7500R AF (-1, -6, -8, -9), 7500R DF (-1), 7500R AL (-6, -8, -9)

Nominal Neck Diameter	fpm Inlet Velocity Ps	300 -.01	400 -.02	500 -.03	600 -.04	700 -.05	800 -.06	900 -.08	1000 -.10
6	CFM	60	80	100	115	135	155	175	195
8	CFM	105	140	175	210	245	280	315	350
10	CFM	165	220	270	325	380	435	490	545
12	CFM	235	315	390	470	550	630	705	785
14	CFM	320	425	535	640	750	855	9300	1070
16	CFM	420	560	700	835	975	1115	1255	1395
18	CFM	520	700	870	1045	1220	1395	1570	1740

### Performance Notes:

All data are tested in accordance with ANSI/ASHRAE 70-1991

### Definition of Units:

- CFM - Cubic feet per minute (air)
- fpm - Velocity of air stream in feet per minute
- Pv - Velocity pressure (inches of water column)
- Pt - Total pressure (inches of water column)
- Ps - Static pressure = Pt - Pv (inches of water column)
- Throw\* - Non-isothermal horizontal throw (supply air temperature 15°F colder than average room air temperature) values are for 150 fpm - 100 fpm - 50 fpm velocities
- Throw - Isothermal horizontal throw (supply air temperature the same as average room air temperature) values are for 150 fpm - 100 fpm - 50 fpm velocities
- NC - Noise criterion, sound pressure level. NC ratings are based on sound power level (Lw) RE: 10E-12 watts minus a 10 dB room attenuation in all octave bands
- Ak - Area Factors

## Series 7500 - Specification

### Supply – Perforated Face - Round Neck/Series 7500

#### Steel

- 7500-1 - Surface Mounted
- 7500-1 DF - Surface Mounted-Dropped Face
- 7500-6 - T-bar Lay-in
- 7500-8 - Tegular T-bar
- 7500-9 - Donn Finline

#### Aluminum Face - Steel Backpan

- 7500-1 AF - Surface Mounted
- 7500-6 AF - T-bar Lay-in
- 7500-8 AF - Tegular T-bar
- 7500-9 AF - Donn Finline

#### Aluminum

- 7500-6 AL - T-bar Lay-in
- 7500-8 AL - Tegular T-bar

#### Round neck units

Air Outlets shall be steel model 7500 or aluminum face, steel backpan model 7500-AF or all aluminum model 7500-AL manufactured by METALAIR.

Units shall consist of aluminum 51% free area perforated face with 3/16" diameter perforated holes on 1/4" staggered centers. The perforated face shall be hinged allowing access to four adjustable pattern controllers mounted onto the inside face of the outlet. Face shall be secured in place with tension spring clips. Pattern controller blades shall be individually adjustable and allow the discharge pattern to be adjustable from vertical to horizontal.

Outlets shall be field adjustable allowing 1, 2-way opposite, 2-way corner, 3, and 4-way directional air patterns.

The units shall be the size and quantity as outline in the plans and specifications.

Units shall be designed to integrate into the specified ceiling system.

### Return - Return or Exhaust – Perforated Face - Round Neck/Series 7500R

#### Steel

- 7500R-1 - Surface Mounted
- 7500R-1 DF - Surface Mounted-Dropped Face
- 7500R-6 - T-bar Lay-in
- 7500R-8 - Tegular T-bar
- 7500R-9 - Donn Finline

#### Aluminum Face - Steel Backpan

- 7500R-1 AF - Surface Mounted
- 7500R-6 AF - T-bar Lay-in
- 7500R-8 AF - Tegular T-bar
- 7500R-9 AF - Donn Finline

#### Aluminum

- 7500R-6 AL - T-bar Lay-in
- 7500R-8 AL - Tegular T-bar

#### Round neck units

Air Inlets shall be steel model 7500R or aluminum face, steel backpan model 7500R-AF or all aluminum model 7500R-AL manufactured by METALAIR.

Units shall consist of aluminum 51% free area perforated face with 3/16" diameter perforated holes on 1/4" staggered centers. Units shall be designed for use in ducted return or exhaust applications.

The perforated face shall be hinged allowing access to the inside of the packpan. Face shall be secured in place with tension spring clips.

The units shall be the size and quantity as outline in the plans and specifications.

Units shall be designed to integrate into the specified ceiling system.







## Optional Dampers and Accessories

### **Butterfly Damper**

METALAIRES model BDS aluminum round butterfly type dampers shall be provided. Damper shall consist of two butterfly style blades that can be adjusted from full open to full closed. Damper shall be adjusted with a screw driver slot that can be assessed through the face of the diffuser.

### **Radial Shutter Damper**

METALAIRES model RSD steel round radial shutter damper shall be provided. Damper shall consist of gang operated radial blades that slide perpendicular to air flow direction. The damper shall be adjusted from full open to full closed. Damper shall be adjusted with a screw driver slot that can be assessed through the face of the diffuser.

### **Opposed Blade Damper**

METALAIRES model D3 aluminum or SD3 steel round opposed blade type dampers shall be provided. Damper shall consist of gang operated blades that can be adjusted from full open to full closed. Damper shall be adjusted with a screw driver slot that can be assessed through the face of the diffuser.

### **Equalizing Grid**

METALAIRES model G3 aluminum round equalizing grid shall be provided. Equalizing grid shall consist of 1/2" x 1/2" x 1/2" aluminum cubed core mounting in an aluminum frame.

## Performance Specification

The manufacturer shall provide published performance data. Data shall be tested in accordance to ANSI/ASHRAE Standard 70-1991.

## Paint Specification

Process shall be anodic electrodeposition using an anodic acrylic paint. Units shall undergo pre-treatment including a pressurized spray stage using an alkaine cleaner and a de-ionized water rinse.

Film Properties shall meet or exceed the following standards:

Property	Test Method	Performance
Film thickness		.8-1.0 mils
Film Cure		320 F @ 20 min
Gloss – 60 deg.	ASTM D523-89	70-80%
Pencil Hardness	ASTM D3363-92A	HB-H
Crosshatch Adhesion	ASTM D3359-95	4B-5B
Direct Impact	ASTM D2794-93	100 in.lbs. Min
Reverse Impact	ASTM D2794-93	60 in.lbs. Min.
Salt Spray	ASTM B117-95	48-96 Hours
Humidity	ASTM D1735-92	500 Hours
Water Soak	ASTM D870-92	250 Hours



# PCD - Perforated Ceiling Diffusers

## Series 7500 - Model Specification Guide

### Perforated Ceiling Diffuser - Round Necks - Face Mounted Pattern Controllers

#### Series 7500 - Supply

Model	Available Neck	Module	Available Finishes	Available Options	
7500-1 - Flush Surface Mount Steel Face & Backpan	6"	12" x 12" 24" x 24"	Standard	G3	Equalizing Grid
	8"		01 -White	BDS	Butterfly Damper
7500-1 DF - Flush Surface Mount - Drop Face Steel Face & Backpan	10"		Optional	RSD	Radial Shutter Damper
	12"		03 - Black	D3	Round Opposed Blade Damper - Aluminum
7500-1 AF - Flush Surface Mount Aluminum Face/Steel Backpan	14"		22 - Black Back pan White Face	SD3	Round Opposed Blade Damper - Steel
	16"		28 - Custom Color		

Model	Available Neck	Module	Available Finishes	Available Options	
7500-6 - T-bar Lay-in - Steel Face & Backpan 7500-6 AF - T-bar Lay-in Aluminum Face/Steel Backpan	6"	12" x 12" 24" x 24"	Standard	G3	Equalizing Grid
	8"		01 -White	BDS	Butterfly Damper
7500-6 AL - T-bar Lay-in - All Aluminum 7500-8 - Tegular T-bar - Steel Face & Backpan	10"		Optional	RSD	Radial Shutter Damper
	12"		03 - Black	D3	Round Opposed Blade Damper - Aluminum
7500-8 AF - Tegular T-bar Aluminum Face/Steel Backpan	14"		22 - Black Back pan White Face	SD3	Round Opposed Blade Damper - Steel
	16"		28 - Custom Color		
7500-8 AL - Tegular T-bar - All Aluminum					
7500-9 - Donn Finline - Steel Face & Backpan					

### Perforated Ceiling Diffuser - Round Necks

#### Series 7500R - Return

Model	Available Neck	Module	Available Finishes	Available Options	
7500R-1 - Flush Surface Mount Steel Face & Backpan	6"	12" x 12" 24" x 24"	Standard	G3	Equalizing Grid
	8"		01 -White	BDS	Butterfly Damper
7500R-1 DF - Flush Surface Mount - Drop Face Steel Face & Backpan	10"		Optional	RSD	Radial Shutter Damper
	12"		03 - Black	D3	Round Opposed Blade Damper - Aluminum
7500R-1 AF - Flush Surface Mount Aluminum Face/Steel Backpan	14"		22 - Black Back pan White Face	SD3	Round Opposed Blade Damper - Steel
	16"		28 - Custom Color		

Model	Available Neck	Module	Available Finishes	Available Options	
7500R-6 - T-bar Lay-in - Steel Face & Backpan 7500R-6 AF - T-bar Lay-in Aluminum Face/Steel Backpan	6"	12" x 12" 24" x 24"	Standard	G3	Equalizing Grid
	8"		01 -White	BDS	Butterfly Damper
7500R-6 AL - T-bar Lay-in - All Aluminum 7500R-8 - Tegular T-bar - Steel Face & Backpan	10"		Optional	RSD	Radial Shutter Damper
	12"		03 - Black	D3	Round Opposed Blade Damper - Aluminum
7500R-8 AF - Tegular T-bar Aluminum Face/Steel Backpan	14"		22 - Black Back pan White Face	SD3	Round Opposed Blade Damper - Steel
	16"		28 - Custom Color		
7500R-8 AL - Tegular T-bar - All Aluminum					
7500R-9 - Donn Finline - Steel Face & Backpan					

### Perforated Ceiling Diffuser - Metric - Round Necks

#### Series 7500 - T-bar Lay-in

Model	Available Neck	Module	Available Finishes	Available Options	
M7500-6 - Supply M7500R-6 - Return	6"	600 x 600	Standard	G3	Equalizing Grid
	8"		01 -White	BDS	Butterfly Damper
	10"		Optional	RSD	Radial Shutter Damper
	12"		03 - Black	D3	Round Opposed Blade Damper - Aluminum
	14"		22 - Black Back pan White Face	SD3	Round Opposed Blade Damper - Steel
	16"		28 - Custom Color		



# PCD - Perforated Ceiling Diffusers

8/2006

- ➔ Supply/Return Perforated Ceiling Diffusers ➔ Square Necks
- ➔ Face Mounted Adjustable Pattern Controllers

## Product Details

- ★ Series 7550 perforated supply diffusers have 4 adjustable pattern controllers mounted on the face of the diffuser.
- ★ Series 7550 are square neck diffusers
- ★ The hinged, fully removable face allow access to the pattern controllers
- ★ Unit can be adjusted for 1-way, 2-way opposite, 2-way corner, 3-way, and 4-way patterns. In 4-way pattern, Series 7550 provides a 360° tight horizontal circular pattern along the ceiling
- ★ Border type 6 can be used in surface mounting applications by adding optional T-bar plaster frame (TBPF)
- ★ Matching returns available: 7500R (round neck) and 7550R (square neck)
- ★ Series 7550 is an excellent choices for VAV applications

Series 7550	
7550	Steel Backpan & Face
7550 AF	Steel Backpan & Aluminum Face
7550 AL	Aluminum Backpan & Face

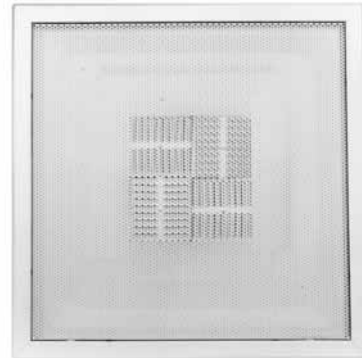

**Model 7550-1**  
Standard Finish: 01 White

Perforated Ceiling Diffusers



PCD

## Supply

Dimensions are in inches

### Supply - Square Neck - Adjustable - Surface Mount

- Model 7550-1 - Steel backpan & face
- Model 7550-1 DF - Steel backpan & face - drop face
- Model 7550-1 AF - Steel backpan & aluminum face

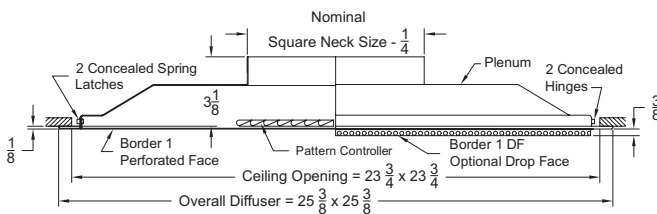

### Supply - Square Neck - Adjustable - T-bar Lay-in

- Model 7550-6 - Steel backpan & face
- Model 7550-6 AF - Steel backpan & aluminum face
- Model 7550-6 AL - Aluminum backpan & face

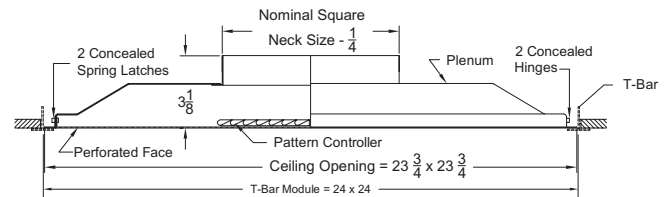

### Supply - Square Neck - Adjustable - Tegular T-bar

- Model 7550-8 - Steel backpan & face
- Model 7550-8 AF - Steel backpan & aluminum face
- Model 7550-8 AL - Aluminum backpan & face

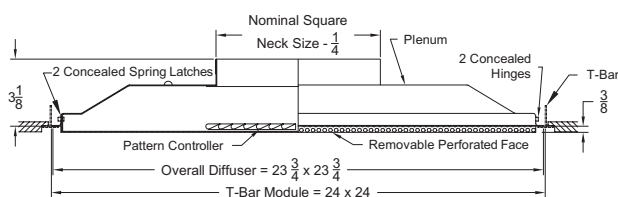

### Supply - Square Neck - Adjustable - Donn Fineline

- Model 7550-9 - Steel backpan & face

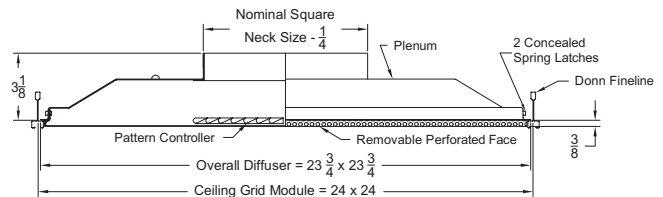

# PCD - Perforated Ceiling Diffusers

## Return

### Return - Square Neck - Surface Mount

- Model 7550R-1 - Steel backpan & face (24" x 24")
- Model 7550R-1 DF - Steel backpan & drop face (24" x 24")
- Model 7550R-1 AF - Steel backpan & aluminum face (24" x 24")

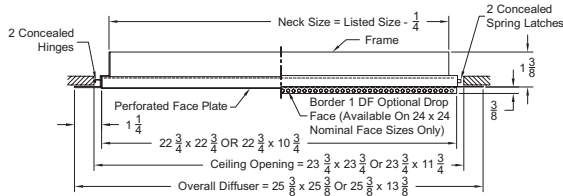

### Return - Square Neck - Surface Mount

- Model 7550R-1 - Steel backpan & face (12" x 12")
- Model 7550R-1 DF - Steel backpan & drop face (12" x 12")
- Model 7550R-1 AF - Steel backpan & aluminum face (12" x 12")

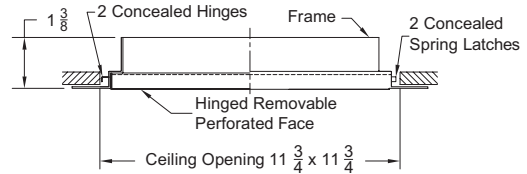

### Return - Square Neck - T-bar Lay-in

- Model 7550R-6 - Steel backpan & face (24" x 24")
- Model 7550R-6 AF - Steel backpan & aluminum face (24" x 24")
- Model 7550R-6 AL - Aluminum backpan & face (24" x 24")

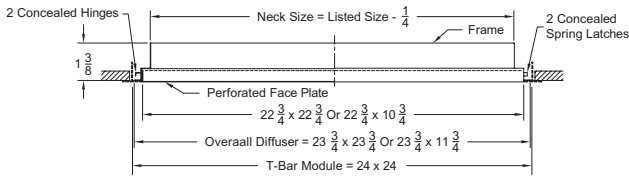

### Return - Square Neck - T-bar Lay-in

- Model 7550R-6 - Steel backpan & face (12" x 12")
- Model 7550R-6 AF - Steel backpan & aluminum face (12" x 12")

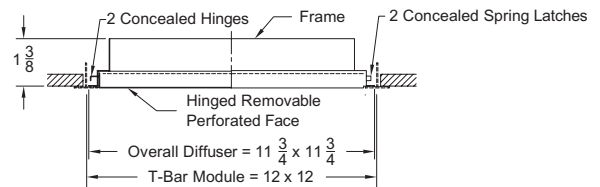

### Return - Square Neck - T-bar Lay-in

- Model 7550R-8 - Steel backpan & face (24" x 24")
- Model 7550R-8 AF - Steel backpan & aluminum face (24" x 24")
- Model 7550R-8 AL - Aluminum backpan & face (24" x 24")

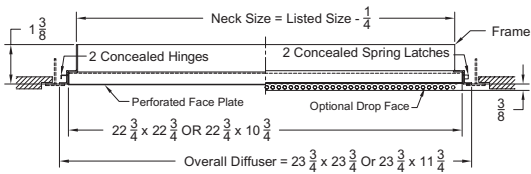

### Return - Square Neck - Tegular T-bar

- Model 7550R-8 - Steel backpan & face (12" x 12")
- Model 7550R-8 AF - Steel backpan & aluminum face (12" x 12")

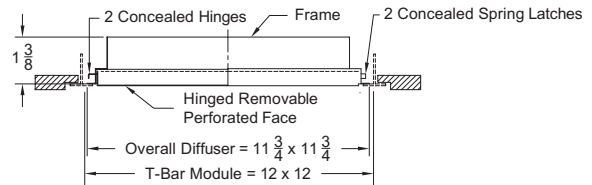

### Return - Square Neck - Donn Finline

- Model 7550R-9 - Steel backpan & face (24" x 24")
- Model 7550R-9 AF - Steel backpan & aluminum face (24" x 24")

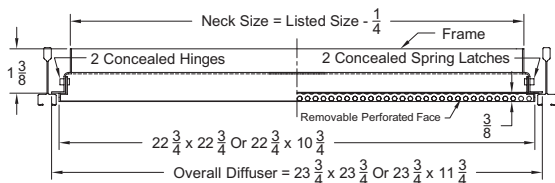

# PCD - Perforated Ceiling Diffusers

8/2006

Perforated Ceiling Diffusers



PCD

**Metric**

Dimensions are in millimeters

**Supply - Square Neck - Adjustable - T-bar Lay-in**  
 Model M7550-6 - Steel backpan & face  
 Model M7550-6 AF - Steel backpan & aluminum face  
 Model M7550-6 AL - Aluminum backpan & face

**Return - Square Neck - Adjustable - T-bar Lay-in**  
 Model M7550R-6 - Steel backpan & face  
 Model M7550R-6 AF - Steel backpan & aluminum face  
 Model M7550R-6 AL - Aluminum backpan & face

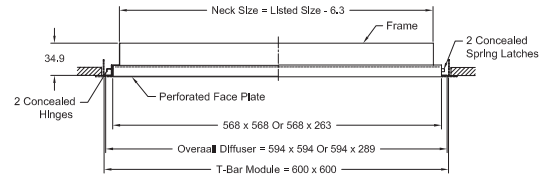
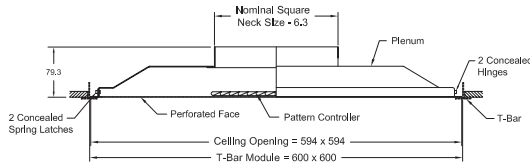

Notes for Models 7550 (-1, -6, -8, -9), 7550-1 DF, 7550 AF (-1, -6, -8, -9), 7550 AL (-6, -8)

1. Available Finishes	2. Available Accessories	3. Construction Details
<p><b>Standard Finish:</b>                      01 White  <b>Optional Finish</b>                      03 Black                      22 (BBP) Black back pan/white face                      28 Custom color</p>	<p><b>All accessories shipped unattached</b>  <b>Square Necks:</b>                      OBD - Opposed blade damper - Steel .....334                      OBDA - Opposed blade damper - Aluminum ...334                      L9 - Equalizing grid .....334  <b>Round Neck:</b>                      G3 - Round Equalizing Grid .....337                      BDS - Butterfly damper .....335                      RSD - Radial Shutter damper .....336</p>	<ul style="list-style-type: none"> <li>• Pattern controllers are mounted on the back side of the perforated face and can be adjusted 1, 2, 3 or 4 way pattern</li> <li>• Pattern controller on 12" x 12" unit is a non adjustable disc on the perforated face</li> <li>• 7550 has 3/16" diameter holes on 1/4" staggered centers</li> </ul>

Notes for Models 7550R (-1, -6, -8, -9), 7550R-1 DF, 7550R AF (-1, -6, -8, -9), 7550R AL (-6, -8)

1. Available Finishes	2. Available Accessories	3. Construction Details
<p><b>Standard Finish:</b>                      01 White  <b>Optional Finish</b>                      02 Aluminum paint                      03 Black                      28 Custom color</p>	<p><b>All accessories shipped unattached</b>  <b>Square Necks:</b>                      OBD - Opposed blade damper - Steel .....334                      OBDA - Opposed blade damper - Aluminum ...334  <b>Round Neck:</b>                      BDS - Butterfly damper .....335                      RSD - Radial Shutter damper .....336</p>	<ul style="list-style-type: none"> <li>• 7550R has 3/16" diameter holes on 1/4" staggered centers</li> </ul>

# PCD - Perforated Ceiling Diffusers

## Series 7550 - Performance/Flush Face - Square Neck

Models 7550 (-1, -6), 7550 AF (-1, -6), 7550 AL (-6)

Listed Size	Neck Size	fpm Neck Velocity Pv	300 0.006	400 0.010	500 0.016	600 0.022	700 0.031	800 0.040	1000 0.062	1200 0.090	
12" x 12"	6"	CFM Pt	75 0.013	100 0.023	125 0.036	150 0.052	175 0.071	200 0.093	250 0.145	300 0.209	
		Throw	4*-Way 4-Way 3-Way 2-Way 1-Way NC	1-2-4 1-2-4 1-2-5 1-3-5 2-3-5 -	1-3-5 1-3-5 1-3-6 2-4-6 2-4-6 -	2-3-6 2-3-6 2-4-6 3-5-7 3-5-7 <15	3-4-6 3-4-7 3-5-7 4-5-7 4-5-7 19	3-4-7 3-5-7 4-5-8 4-6-8 4-6-8 25	3-5-7 4-5-8 4-6-8 5-6-8 5-6-9 29	4-6-8 4-6-9 4-6-9 5-7-9 6-7-10 36	5-6-9 5-7-10 6-7-10 6-7-10 6-7-10 41
	8"	CFM Pt	135 0.017	180 0.031	220 0.046	265 0.067	310 0.092	355 .121	445 0.190	535 0.275	
		Throw	4*-Way 4-Way 3-Way 2-Way 1-Way NC	1-2-5 1-2-5 1-2-6 2-4-7 2-4-7 -	2-3-7 2-4-7 2-4-8 3-5-8 3-5-8 -	3-4-8 3-4-8 3-5-9 4-6-9 4-6-9 <15	3-5-8 4-5-9 4-6-9 5-7-10 5-7-10 20	4-6-9 4-6-10 5-7-10 6-7-10 6-8-11 27	5-7-10 5-7-11 5-8-11 6-8-11 6-8-11 32	6-8-11 6-8-12 7-9-12 7-9-12 7-9-13 39	7-8-12 7-9-13 8-9-13 8-10-14 8-10-14 45
	24 x 24	6"	CFM Pt	75 0.013	100 0.023	125 0.036	150 0.052	175 0.071	200 0.093	250 0.145	300 0.209
			Throw	4*-Way 4-Way 3-Way 2-Way 1-Way NC	1-2-4 1-2-4 1-2-5 2-3-5 2-3-6 -	1-3-5 1-3-6 1-3-6 3-4-6 3-4-6 -	2-3-6 2-4-7 2-4-7 3-5-7 3-5-7 <15	3-4-7 3-4-7 3-5-7 4-5-8 4-6-8 19	3-5-7 4-5-8 4-6-8 5-6-9 4-6-8 25	4-5-8 4-6-8 4-6-9 5-6-9 5-6-9 29	5-6-9 5-7-9 5-7-10 6-7-10 6-7-10 36
CFM Pt			135 0.017	180 0.031	220 0.046	265 0.067	310 0.092	355 0.121	445 0.190	535 0.275	
8"		Throw	4*-Way 4-Way 3-Way 2-Way 1-Way NC	1-3-5 1-2-6 1-2-6 2-4-7 2-4-7 -	2-4-7 2-4-8 2-4-8 3-5-8 3-5-9 -	3-4-8 3-5-9 3-5-9 4-6-9 4-6-9 <15	4-5-9 4-6-10 4-6-10 5-7-10 5-7-10 20	4-6-10 4-7-10 5-7-11 6-8-11 6-8-11 27	5-7-10 5-7-11 6-8-11 7-8-12 7-8-12 32	6-8-11 6-9-13 6-8-11 8-9-13 8-9-13 39	7-9-13 7-10-14 8-10-14 8-10-14 8-10-15 45
		CFM Pt	210 0.023	280 0.040	345 0.061	415 0.088	485 0.120	555 0.158	695 0.247	835 0.357	
		Throw	4*-Way 4-Way 3-Way 2-Way 1-Way NC	1-3-7 1-3-7 1-3-8 3-5-9 3-5-9 -	3-5-9 2-5-9 2-5-10 4-6-10 4-6-11 -	4-6-10 4-6-11 4-7-11 5-8-12 5-8-12 <15	4-7-11 5-7-12 5-8-12 6-9-13 6-9-13 22	5-8-12 5-8-13 6-9-13 7-10-14 7-10-14 29	6-9-13 6-9-14 7-10-14 8-10-15 8-11-15 34	8-10-14 8-11-16 9-11-16 9-12-16 10-12-17 42	9-11-16 9-12-17 10-12-18 10-13-18 11-13-18 47
12"		CFM Pt	300 0.023	400 0.040	500 0.063	600 0.090	700 0.123	800 0.160	1000 0.250	1200 0.360	
		Throw	4*-Way 4-Way 3-Way 2-Way 1-Way NC	2-4-8 2-4-8 2-4-10 3-6-11 3-6-11 -	3-5-11 3-6-11 3-6-12 5-8-12 5-8-13 <15	5-7-12 4-7-13 4-8-14 6-10-14 6-10-14 15	5-8-13 6-8-15 6-10-15 8-11-15 8-11-16 23	6-9-14 7-10-16 7-11-16 9-12-16 9-12-17 30	7-11-15 7-11-17 9-12-17 10-12-18 10-13-18 35	9-12-17 9-13-19 11-14-19 11-14-20 12-14-20 44	11-13-19 11-15-21 12-15-21 12-15-21 13-16-22 50
		CFM Pt	410 0.023	545 0.041	680 0.064	815 0.092	955 0.126	1090 0.164	1360 0.255	1635 0.369	
14"		Throw	4*-Way 4-Way 3-Way 2-Way 1-Way NC	2-4-9 2-4-10 2-4-11 4-7-13 4-7-13 -	3-6-13 3-7-13 3-7-14 6-9-14 6-9-15 <15	5-8-14 5-8-15 5-9-16 7-11-16 7-11-17 16	6-9-16 7-10-17 7-11-17 9-13-18 9-13-18 24	7-11-17 8-11-18 9-13-19 10-14-19 10-14-20 31	8-13-18 9-13-20 10-14-20 12-14-20 12-15-21 37	10-14-20 11-15-22 12-16-22 13-16-23 14-17-23 46	13-16-22 13-17-24 14-17-25 14-18-25 15-18-26 51
		CFM Pt	535 0.026	710 0.046	890 0.073	1065 0.104	1245 0.143	1420 0.186	1780 0.291	2135 0.419	
		Throw	4*-Way 4-Way 3-Way 2-Way 1-Way NC	2-5-11 2-5-11 2-5-13 4-8-14 4-8-15 -	4-7-14 4-7-15 4-9-16 7-10-17 7-10-17 <15	6-9-16 6-9-18 6-11-18 8-13-18 8-13-19 16	7-11-18 7-11-19 9-13-20 10-14-20 10-15-21 24	8-13-19 9-13-21 10-15-21 12-15-22 12-16-22 33	10-14-21 10-15-22 11-16-23 13-17-23 13-17-24 39	12-16-23 12-18-25 14-18-26 15-18-26 16-19-27 49	14-18-25 15-19-27 16-20-28 17-20-29 17-21-29 53

See Page PCD-131 for Series 7550/7550R Performance Notes

Perforated Ceiling Diffusers



PCD

# PCD - Perforated Ceiling Diffusers

## Series 7550 - Performance/Drop Face - Square Neck

Models 7550 (-8, -9), 7550-1 DF, 7550 AF (-8, -9), 7550 AL (-8)

Perforated Ceiling Diffusers



PCD

Listed Size	Neck Size	fpm Neck Velocity Pv	300 0.006	400 0.010	500 0.016	600 0.022	700 0.031	800 0.040	1000 0.062	1200 0.090
12" x 12"	6"	CFM Pt	75 0.012	100 0.022	125 0.034	150 0.048	175 0.066	200 0.086	250 0.134	300 0.194
		Throw	4*-Way	1-1-3	1-2-4	1-2-4	2-3-4	2-3-5	2-4-5	3-4-6
	4-Way		1-2-5	2-3-6	2-4-7	3-5-8	4-5-8	4-6-9	5-7-10	6-8-11
	3-Way		1-2-5	2-3-6	3-4-7	3-5-8	4-5-8	4-6-9	5-7-10	6-8-11
	2-Way		1-3-5	2-4-6	3-5-7	4-5-8	4-6-9	5-6-9	6-7-10	6-8-11
	1-Way		2-3-6	3-4-7	3-5-7	4-6-8	5-6-9	5-7-9	6-7-10	7-8-11
	NC	-	-	<15	19	25	29	35	40	
	8"	CFM Pt	135 0.016	180 0.028	220 0.042	265 0.061	310 0.084	355 0.110	445 0.172	535 0.249
		Throw	4*-Way	1-2-4	2-2-5	2-3-5	2-4-6	3-4-6	3-5-7	4-5-8
	4-Way		1-3-6	2-4-8	3-5-9	4-6-10	5-7-11	5-8-12	7-9-13	8-10-15
3-Way	1-3-6		2-4-8	3-5-9	4-6-10	5-7-11	5-8-12	7-9-13	8-10-15	
2-Way	2-4-7		3-5-9	4-6-10	5-7-10	6-8-11	6-9-12	8-10-14	9-11-15	
1-Way	2-4-8		4-6-9	5-7-10	6-8-11	6-8-12	7-9-12	8-10-14	9-11-15	
NC	-	-	<15	20	27	32	39	44		
24" x 24"	6"	CFM Pt	75 0.012	100 0.022	125 0.034	150 0.048	175 0.066	200 0.086	250 0.134	300 0.194
		Throw	4*-Way	1-1-3	1-2-4	2-2-4	2-3-5	2-3-5	2-4-5	3-4-6
	4-Way		1-2-5	2-3-6	3-4-7	3-5-8	4-6-9	4-6-9	5-7-11	6-8-12
	3-Way		1-2-5	2-3-6	3-4-7	3-5-8	4-6-9	4-6-9	5-7-11	6-8-12
	2-Way		2-3-6	3-4-7	3-5-8	4-6-8	4-6-9	5-7-10	6-8-11	7-8-12
	1-Way		2-3-6	3-4-7	4-5-8	4-6-8	5-6-9	6-7-10	6-8-11	7-8-12
	NC	-	-	<15	19	25	29	35	40	
	8"	CFM Pt	135 0.016	180 0.028	220 0.042	265 0.061	310 0.084	355 0.110	445 0.172	535 0.249
		Throw	4*-Way	1-2-4	2-3-5	2-3-6	2-4-6	3-4-7	3-5-7	4-6-8
	4-Way		1-3-6	2-4-9	3-5-10	4-6-11	5-7-12	6-9-13	7-10-14	9-11-15
	3-Way		1-3-6	2-4-9	3-5-10	4-6-11	5-7-12	6-9-13	7-10-14	9-11-15
	2-Way		2-4-8	3-5-9	4-6-10	5-8-11	6-8-12	7-9-13	8-10-14	9-11-16
	1-Way		2-4-8	4-6-9	5-7-10	6-8-11	7-9-12	8-9-13	8-10-15	9-11-16
	NC	-	-	<15	20	27	32	39	44	
	10"	CFM Pt	210 0.020	280 0.028	220 0.042	265 0.061	310 0.084	355 0.110	445 0.172	535 0.249
		Throw	4*-Way	1-2-5	2-3-6	3-4-7	3-5-8	4-5-8	4-6-9	5-7-10
	4-Way		2-4-8	3-5-11	4-7-12	5-8-14	6-9-15	7-11-16	9-12-18	11-14-19
	3-Way		2-4-8	3-5-11	4-7-12	5-8-14	6-9-15	7-11-16	9-12-18	11-14-19
	2-Way		3-5-10	4-6-11	5-8-13	6-9-14	7-11-15	8-11-16	10-13-18	11-14-20
	1-Way		3-6-10	5-7-12	6-9-13	7-10-14	9-11-15	9-12-16	11-13-18	12-14-20
NC	-	-	<15	23	30	35	42	46		
12"	CFM Pt	300 0.021	400 0.037	500 0.058	600 0.083	700 0.113	800 0.147	1000 0.230	1200 0.331	
	Throw	4*-Way	2-3-6	2-4-7	3-5-9	4-6-9	4-7-10	5-7-11	6-9-12	7-9-13
4-Way		2-4-10	3-6-13	5-8-15	6-10-16	7-11-18	9-13-19	11-15-21	13-16-23	
3-Way		2-5-10	4-6-13	5-8-15	6-10-16	7-11-18	9-13-19	11-15-21	13-16-23	
2-Way		3-6-11	5-8-14	6-10-15	8-11-17	9-13-18	10-14-19	12-15-21	14-17-24	
1-Way		4-7-12	6-9-14	7-11-15	9-12-17	10-13-18	11-14-20	13-15-22	14-17-24	
NC	-	<15	15	24	31	37	44	50		
14"	CFM Pt	410 0.023	545 0.040	680 0.062	815 0.089	955 0.122	1090 0.159	1360 0.248	1635 0.358	
	Throw	4*-Way	2-3-7	3-4-9	4-5-10	4-6-11	5-8-12	6-9-13	7-10-14	9-11-16
4-Way		2-5-11	4-7-15	6-9-17	7-11-19	9-13-21	10-15-22	12-17-25	15-19-27	
3-Way		2-5-11	4-7-15	6-9-17	7-11-19	9-13-21	10-15-22	12-17-25	15-19-27	
2-Way		4-7-13	6-9-16	7-11-18	9-13-19	10-15-21	12-16-22	14-18-25	16-19-27	
1-Way		4-8-14	7-10-16	9-13-18	10-14-20	12-15-21	13-16-23	15-18-26	16-20-28	
NC	-	<15	17	26	34	40	48	53		
16"	CFM Pt	535 0.024	710 0.043	890 0.067	1065 0.096	1245 0.132	1420 0.171	1780 0.269	2135 0.387	
	Throw	4*-Way	2-4-7	3-5-10	4-6-11	5-7-13	6-9-14	7-10-14	8-11-16	10-13-18
4-Way		2-6-13	4-9-17	7-11-20	9-13-22	10-15-23	11-17-25	14-20-28	17-22-31	
3-Way		3-6-13	5-9-17	7-11-20	9-13-22	10-15-23	11-17-25	14-20-28	17-22-31	
2-Way		4-8-15	7-10-18	8-13-20	10-15-22	12-17-24	13-18-26	17-20-29	18-22-31	
1-Way		5-9-16	8-12-18	10-15-21	12-16-23	14-17-24	15-18-26	17-21-29	18-23-32	
NC	-	<15	18	28	36	42	51	56		

See Page PCD-131 for Series 7550/7550R Performance Notes

# PCD - Perforated Ceiling Diffusers

## Series 7550R - Square Neck

Models 7550R (-1, -6, -8, -9), 7550R-1 DF, 7550R AF (-1, -6, -8), 7550R AL (-6, -8)

Nominal Neck Size	fpm Inlet Velocity	300	400	500	600	700	800	900	1000
		PS	-0.08	-0.15	-0.2	-0.3	-0.5	-0.6	-0.8
6" x 6"	CFM	75	100	120	150	175	200	225	250
8" x 8"	CFM	130	175	220	265	310	350	400	445
10" x 10"	CFM	210	275	345	415	485	555	625	695
12" x 12"	CFM	300	400	500	600	700	800	900	1000
14" x 14"	CFM	410	545	680	815	950	1090	1225	1360
16" x 16"	CFM	530	710	885	1060	1240	1415	1600	1770
22" x 22"	CFM	1010	1345	1680	2015	2350	2690	3025	3360

### Performance Notes:

All data are tested in accordance with ANSI/ASHRAE 70-1991

### Definition of Units:

- CFM** - Cubic Feet per Minute (air)
- fpm** - Velocity of air stream in Feet Per Minute
- Pv** - Velocity pressure (inches of water column)
- Pt** - Total pressure (inches of water column)
- Ps** - Static pressure = Pt - Pv (inches of water column)
- Throw\*** - Non-isothermal horizontal throw (supply air temperature 15°F colder than average room air temperature) values are for 150 fpm - 100 fpm - 50 fpm velocities
- Throw** - Isothermal horizontal throw (supply air temperature the same as average room air temperature) values are for 150 fpm - 100 fpm - 50 fpm velocities
- NC** - Noise criterion, sound pressure level. NC ratings are based on sound power level (Lw) RE: 10E-12 watts minus a 10 dB room attenuation in all octave bands





## Series 7550/7550R - Specification

### Supply - Perforated Diffuser - Face Mounted Adjustable Pattern Controller - Square Necks/Series 7550

<b>Steel</b>	<b>Aluminum Face - Steel Backpan</b>	<b>Aluminum</b>
7550-1 - Surface Mounted	7550-1 AF - Surface Mounted	7550-6 AL - T-bar Lay-in
7550-1 DF - Surface Mounted-Dropped Face	7550-6 AF - T-bar Lay-in	7550-8 AL - Tegular T-bar
7550-6 - T-bar Lay-in	7550-8 AF - Tegular T-bar	
7550-8 - Tegular T-bar	7550-9 AF - Donn Finline	
7550-9 - Donn Finline		

Air Outlets shall be steel model 7550 or aluminum face, steel backpan model 7550-AF or all aluminum model 7550-AL manufactured by METALAIRES.

Units shall consist of aluminum 51% free area perforated face with 3/16" diameter perforated holes on 1/4" staggered centers. The perforated face shall be hinged allowing access to four adjustable pattern controllers mounted onto the inside face of the outlet. Face shall be secured in place with tension spring clips. Pattern controller blades shall be individually adjustable and allow the discharge pattern to be adjustable from vertical to horizontal.

Outlets shall be field adjustable allowing 1, 2 way opposite, 2 way corner, 3, and 4 way directional air patterns.

The units shall be the size and quantity as outline in the plans and specifications.

Units shall be designed to integrate into the specified ceiling system.

### Return - Perforated Diffuser - Square Necks - 12" x 12"/24" x 24"/Series 7550R

<b>Steel</b>	<b>Aluminum Face - Steel Backpan</b>	<b>Aluminum</b>
7550R-1 - Surface Mounted	7550R-1 AF - Surface Mounted	7550R-6 AL - T-bar Lay-in
7550R-1 DF - Surface Mounted-Dropped Face	7550R-6 AF - T-bar Lay-in	7550R-8 AL - Tegular T-bar
7550R-6 - T-bar Lay-in	7550R-8 AF - Tegular T-bar	
7550R-8 - Tegular T-bar	7550R-9 AF - Donn Finline	
7550R-9 - Donn Finline		

Air inlets shall be steel model 7550R or aluminum face, steel backpan model 7550R-AF or all aluminum model 7550R-AL manufactured by METALAIRES.

Units shall consist of aluminum 51% free area perforated face with 3/16" diameter perforated holes on 1/4" staggered centers. Units shall be designed for use in ducted return or exhaust applications.

The perforated face shall be hinged allowing access to the inside of the packpan. Face shall be secured in place with tension spring clips.

The units shall be the size and quantity as outline in the plans and specifications.

Units shall be designed to integrate into the specified ceiling system

### Options and Accessories

#### Opposed Blade Damper

METALAIRES model OBDA aluminum or OBD steel opposed blade type dampers shall be provided. Damper shall consist of gang operated blades that can be adjusted from full open to full closed. Damper shall be adjusted with a screw driver slot accessible by opening the face of the diffuser.

#### Equalizing Grid

METALAIRES model L9 aluminum square equalizing grid shall be provided. Equalizing grid shall consist aluminum blades mounting in an aluminum frame.

### Performance Specification

The manufacturer shall provide published performance data. Data shall be tested in accordance to ANSI/ASHRAE Standard 70-1991.

### Paint Specification

Process shall be anodic electrodeposition using an anodic acrylic paint. Units shall undergo pre-treatment including a pressurized spray stage using an alkaine cleaner and a de-ionized water rinse.

Film Properties shall meet or exceed the following standards:

Property	Test Method	Performance
Film thickness		.8-1.0 mils
Film Cure		320 F @ 20 min
Gloss – 60 deg.	ASTM D523-89	70-80%
Pencil Hardness	ASTM D3363-92A	HB-H
Crosshatch Adhesion	ASTM D3359-95	4B-5B
Direct Impact	ASTM D2794-93	100 in.lbs. Min
Reverse Impact	ASTM D2794-93	60 in.lbs. Min.
Salt Spray	ASTM B117-95	48-96 Hours
Humidity	ASTM D1735-92	500 Hours
Water Soak	ASTM D870-92	250 Hours



# PCD - Perforated Ceiling Diffusers

## Series 7550/7550R - Model Specification Guide

Return and Exhaust - Perforated Supply Diffuser - Square Necks - Face Mounted Pattern Controllers - Steel Frame & Face

Model	Available Neck	Module	Available Finishes		Available Options	
			Standard			
7500-1 - Flush Ceiling Mount 7550-1 DF - Flush Ceiling Mount - Drop Face 7550-1 AF - Flush Ceiling Mount - Aluminum Face	6" x 6" 8" x 8" 10" x 10" 12" x 12" 14" x 14" 15" x 15" 16" x 16" 18" x 18"	12" x 12" 24" x 24"	Standard	OBD	Opposed Blade Damper - Steel	
			01 - White	OBDA	Opposed Blade Damper - Aluminum	
			Optional	L9	Equalizing Grid	
			03 - Black			
			22 - Black Back pan White Face			
			28 - Custom Color			

Model	Available Neck	Module	Available Finishes		Available Options	
			Standard			
7500-6 - T-bar Lay-in 7550-6 AF - T-bar Lay-in - Aluminum Face 7550-6 AL - T-bar Lay-in - Aluminum 7500-8 - Tegular T-bar 7550-8 AF - Tegular T-bar - Aluminum Face 7550-8 AL - Tegular T-bar - Aluminum 7550-9 - Donn Finline	6" x 6" 8" x 8" 10" x 10" 12" x 12" 14" x 14" 15" x 15" 16" x 16"	12" x 12" 24" x 24"	Standard	OBD	Opposed Blade Damper - Steel	
			01 - White	OBDA	Opposed Blade Damper - Aluminum	
			Optional	L9	Equalizing Grid	
			03 - Black			
			22 - Black Back pan White Face			
			28 - Custom Color			

Model	Available Neck	Module	Available Finishes		Available Options	
			Standard			
7500R-1 - Flush Ceiling Mount 7550R-1 DF - Flush Ceiling Mount - Aluminum Face 7550R-1 AF - Flush Ceiling Mount - Aluminum	6" x 6" 8" x 8" 10" x 10" 12" x 12" 14" x 14" 15" x 15" 16" x 16"	12" x 12" 24" x 24"	Standard	OBD	Opposed Blade Damper - Steel	
			01 - White	OBDA	Opposed Blade Damper - Aluminum	
			Optional	L9	Equalizing Grid	
			03 - Black			
			22 - Black Back pan White Face			
			28 - Custom Color			

Model	Available Neck	Module	Available Finishes		Available Options	
			Standard			
7550R-6 - T-bar Lay-in 7550R-6 AF - T-bar Lay-in - Aluminum Face 7550R-6 AL - T-bar Lay-in - Aluminum 7500R-8 - Tegular T-bar 7550R-8 AF - Tegular T-bar - Aluminum Face 7550R-8 AL - Tegular T-bar - Aluminum 7550R-9 - Donn Finline	6" x 6" 8" x 8" 10" x 10" 12" x 12" 14" x 14" 15" x 15" 16" x 16"	12" x 12" 24" x 24"	Standard	OBD	Opposed Blade Damper - Steel	
			01 - White	OBDA	Opposed Blade Damper - Aluminum	
			Optional	L9	Equalizing Grid	
			03 - Black			
			22 - Black Back pan White Face			
			28 - Custom Color			

Perforated Ceiling Diffuser - Metric - Square Necks

Series 7500 - T-bar Lay-in

Model	Available Neck	Module	Available Finishes		Available Options	
			Standard			
M7550-6 - Supply M7550R-6 - Return	6" x 6" 8" x 8" 10" x 10" 12" x 12" 14" x 14" 15" x 15" 16" x 16"	600mm x 600mm	Standard	G3	Equalizing Grid	
			01 - White	BDS	Butterfly Damper	
			Optional	RSD	Radial Shutter Damper	
			03 - Black			
			22 - Black Back pan White Face			
			28 - Custom Color			



# PCD - Perforated Ceiling Diffusers

8/2006

Perforated Ceiling Diffusers



PCD

- ➔ Supply/Return Perforated Ceiling Diffuser ➔ Round Neck
- ➔ Neck Mounted Curved Blade Pattern Controllers

## Product Details

- ✪ The 7600 perforated supply diffuser has curved blade pattern controllers mounted in the neck of the diffuser. Pattern controllers are adjustable from a horizontal to vertical discharge pattern
- ✪ The hinged, fully removable face allow access to the pattern controllers
- ✪ Units are available in 1, 2-way opposite, 2-way corner, 3, and 4-way patterns. The 4-way core can be set for corner or side discharge patterns
- ✪ Border 6, T-bar Lay-in can be used in surface mounting applications by adding optional T-bar Plaster Frame (TBPf)
- ✪ Matching returns available: 7600R (round neck)
- ✪ The 7600 is an excellent choices for VAV applications
- ✪ Also available in square neck series 7650

Series 7600	
7600	Steel Backpan & Face
7600 AF	Steel Backpan & Aluminum Face
7600 AL	Aluminum Backpan & Face

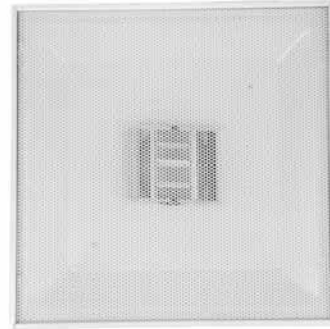

**Model 7600-6 4W Shown**

Standard Finish: 01 White

## Supply - 24" x 24"

Dimensions are in inches

**Supply - Round Neck - Neck Mounted - Adjustable - Surface Mount**  
 Model 7600-1 - Steel backpan & face  
 Model 7600-1 AF - Steel backpan & aluminum face  
 Model 7600-1 DF - Steel backpan & face - drop face

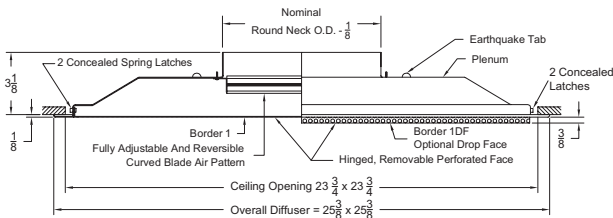

**Supply - Round Neck - Neck Mounted - Adjustable - T-bar Lay-in**  
 Model 7600-6 - Steel backpan & face  
 Model 7600-6 AF - Steel backpan & aluminum face  
 Model 7600-6 AL - Aluminum backpan & face

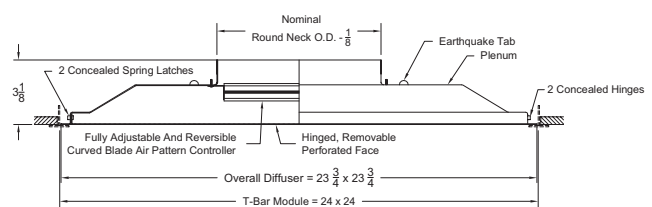

**Supply - Round Neck - Face Mounted - Adjustable - Tegular T-bar**  
 Model 7600-8 - Steel backpan & face  
 Model 7600-8 AF - Steel backpan & aluminum face  
 Model 7600-8 AL - Aluminum backpan & face

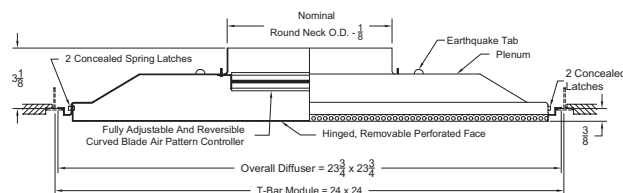

**Supply - Round Neck - Face Mounted - Adjustable - Donn Finline**  
 Model 7600-9 - Steel backpan & face  
 Model 7600-9 AF - Steel backpan & aluminum face

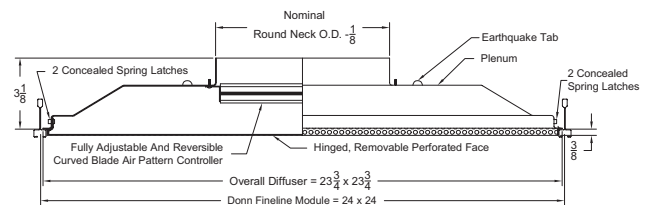

Available Round In lets ( For All Models ): 6, 8, 10, 12, 14, 16

# PCD - Perforated Ceiling Diffusers



## Return

### Return - Round Neck - Surface Mount - 24" x 24"

- Model 7600R-1 - Steel backpan & face
- Model 7600R-1 DF - Steel backpan & face - drop face
- Model 7600R-1 AF - Steel backpan & aluminum face

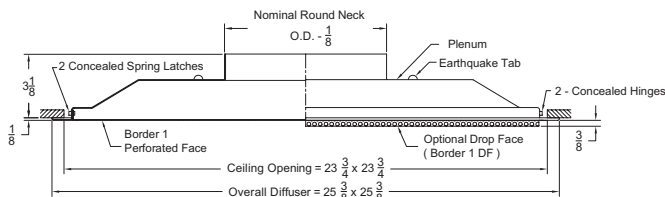

### Return - Round Neck - Surface Mount - 12" x 12"

- Model 7600R-1 - Steel backpan & face
- Model 7600R-1 AF - Steel backpan & aluminum face
- Model 7600R-1 AL - Aluminum backpan & face

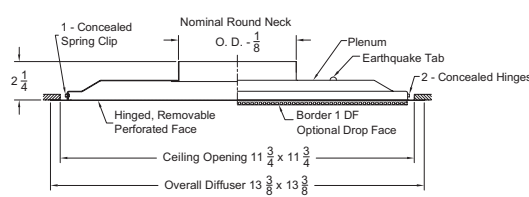

### Return - Round Neck - T-bar Lay-in - 24" x 24"

- Model 7600R-6 - Steel backpan & face
- Model 7600R-6 AF - Steel backpan & aluminum face
- Model 7600R-6 AL - Aluminum backpan & face

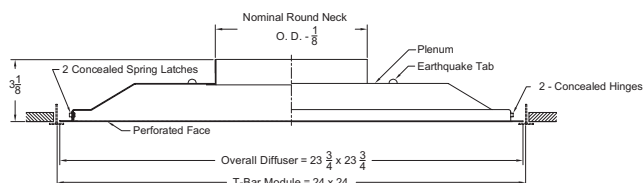

### Return - Round Neck - T-bar Lay-in - 12" x 12"

- Model 7600R-6 - Steel backpan & face
- Model 7600R-6 AF - Steel backpan & aluminum face
- Model 7600R-6 AL - Aluminum backpan & face

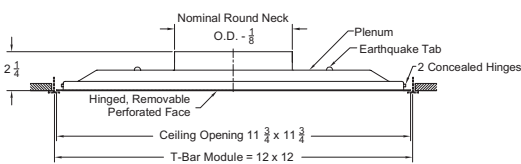

### Return - Round Neck - Tegular T-bar - 24" x 24"

- Model 7600R-8 - Steel backpan & face
- Model 7600R-8 AF - Steel backpan & aluminum face
- Model 7600R-8 AL - Aluminum backpan & face

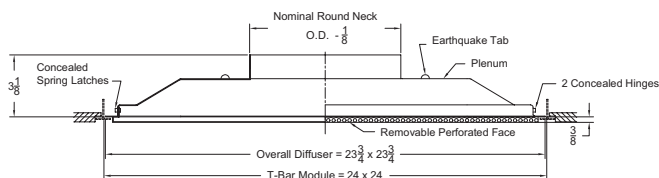

### Return - Round Neck - Tegular T-bar - 12" x 12"

- Model 7600R-8 - Steel backpan & face
- Model 7600R-8 AF - Steel backpan & aluminum face
- Model 7600R-8 AL - Aluminum backpan & face

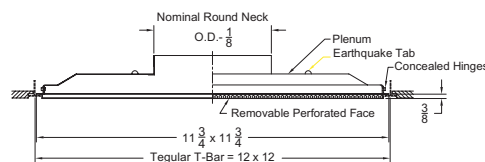

### Return - Round Neck - Donn Finline - 24" x 24"

- Model 7600R-9 - Steel backpan & face
- Model 7600R-9 AF - Steel backpan & aluminum face

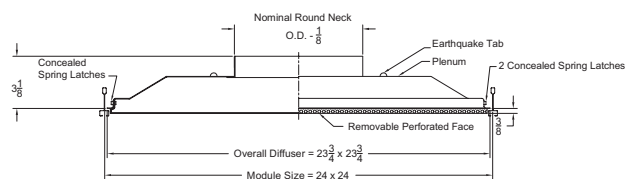

# PCD - Perforated Ceiling Diffusers

8/2006

**Metric**

*Dimensions are in millimeters*

**Supply - Round Neck - T-bar Lay-in**  
Model M7600-6

**Return - Round Neck - T-bar Lay-in**  
Model M7600R-6

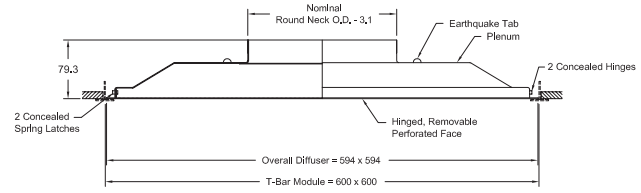
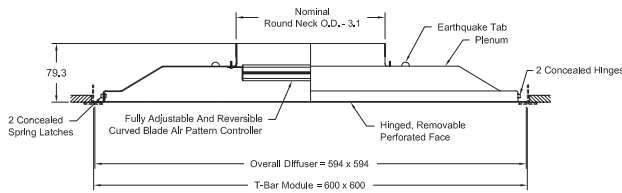

**Notes for Models 7600 (-1, -6, -8, -9) 7600-1 DF, 7600 AF (-1, -6, -8, -9) 7600 AL (-6, -8)**

1. Available Finishes	2. Available Accessories	3. Construction Details
<b>Standard Finish:</b> 01 White <b>Optional Finish</b> 02 Aluminum paint 03 Black 22 (BBP) Black back pan/white face 28 Custom color	<b>All accessories shipped unattached</b> <b>Round Neck:</b> G3 - Equalizing grid .....337 BDS - Butterfly damper .....335 RSD - Radial Shutter damper .....336	<ul style="list-style-type: none"> <li>• Pattern controllers are mounted on the back side of the perforated face and can be adjusted to 1, 2, 3 or 4 way pattern</li> <li>• Seismic tabs standard on all units</li> <li>• 7600 has 3/16" diameter holes in 1/4" centers</li> </ul>

**Notes for Models 7600R (-1, -6, -8, -9), 7600R-1 DF, 7600R AF (-1, -6, -8, -9) 7600R AL (-6, -8)**

1. Available Finishes	2. Available Accessories	3. Construction Details
<b>Standard Finish:</b> 01 White <b>Optional Finish</b> 02 Aluminum paint 03 Black 22 (BBP) Black back pan/white face 28 Custom color	<b>Round Neck:</b> BDS - Butterfly damper .....335 RSD - Radial Shutter damper .....336	<ul style="list-style-type: none"> <li>• Seismic tabs standard on all units</li> <li>• 7600R has 3/16" diameter holes in 1/4" centers</li> </ul>

Perforated Ceiling Diffusers



PCD

# PCD - Perforated Ceiling Diffusers

## Series 7600 - Performance/Flush Face - Round Neck

Models 7600 (-1, -6), 7600 AF (-1, -6), 7600 AL (-6)

Listed Size	Neck Size	fpm Neck Velocity Pv	300 0.006	400 0.010	500 0.016	600 0.022	700 0.031	800 0.040	1000 0.062	1200 0.090	
24" x 24"	6"	CFM	60	80	100	120	135	155	195	235	
		Pt	0.015	0.026	0.041	0.060	0.075	0.099	0.157	0.229	
		Throw	4*-Way	1-1-2	1-2-3	1-2-4	2-2-5	2-3-6	2-3-6	3-4-7	3-5-7
			4-Way	1-2-5	2-3-6	3-4-6	3-5-7	3-5-7	4-5-8	5-6-9	6-7-10
			3-Way	2-3-5	2-3-6	3-4-7	3-5-7	4-6-8	4-6-9	5-7-10	6-7-10
	2-Way		2-3-5	2-4-7	3-5-8	4-5-8	4-6-9	5-7-10	6-8-11	7-8-12	
	1-Way NC		4-6-9	6-8-11	7-8-12	8-9-13	8-10-14	9-10-15	10-12-17	11-13-18	
	CFM	105	140	175	210	245	280	350	420		
	Pt	0.016	0.028	0.044	0.063	0.086	0.112	0.175	0.252		
	8"	Throw	4*-Way	1-2-3	1-2-4	2-3-5	2-3-7	3-4-7	3-4-8	4-5-9	4-7-10
			4-Way	2-3-6	3-4-7	3-5-8	4-6-9	5-7-10	5-7-10	7-8-12	7-9-13
			3-Way	2-3-7	3-4-8	4-5-9	4-7-10	5-8-11	6-8-11	7-9-13	8-10-14
			2-Way	2-4-7	3-5-9	4-6-10	5-7-11	6-8-12	6-9-13	8-10-14	9-11-16
			1-Way NC	5-8-12	7-10-14	9-11-16	10-12-17	11-13-19	11-14-20	13-16-22	14-17-24
	CFM	165	220	275	325	380	435	545	655		
	Pt	0.017	0.030	0.047	0.066	0.090	0.118	0.186	0.268		
	10"	Throw	4*-Way	1-2-4	2-3-5	2-3-7	3-4-8	3-5-9	4-5-10	5-7-11	5-8-12
			4-Way	2-4-8	3-5-9	4-6-10	5-7-11	6-9-12	7-9-13	8-10-15	9-11-16
			3-Way	3-4-8	4-6-10	5-7-11	5-8-12	6-9-13	7-10-14	9-11-16	10-12-18
			2-Way	3-4-9	4-6-11	5-7-13	6-9-14	7-10-15	8-11-16	10-13-18	11-14-20
			1-Way NC	7-10-15	9-12-18	11-14-20	12-15-21	13-16-23	14-18-25	16-20-28	18-21-30
	CFM	235	315	395	470	550	630	785	940		
	Pt	0.018	0.033	0.052	0.074	0.101	0.133	0.206	0.295		
	12"	Throw	4*-Way	2-2-5	2-3-7	3-4-8	3-5-10	4-6-11	4-7-12	5-8-13	7-10-15
4-Way			3-5-9	4-6-11	5-8-12	6-9-13	7-10-15	8-11-16	10-12-17	11-13-19	
3-Way			3-5-10	4-7-12	5-8-14	7-10-15	8-11-16	9-12-17	11-14-19	12-15-21	
2-Way			4-5-11	5-7-14	6-9-15	7-11-17	8-12-18	9-14-19	12-15-21	14-17-23	
1-Way NC			8-12-18	11-15-21	14-17-24	15-18-26	16-20-28	17-21-30	19-24-33	21-26-36	
CFM	320	430	535	640	750	855	1070	1285			
Pt	0.017	0.031	0.048	0.068	0.094	0.122	0.191	0.276			
14"	Throw	4*-Way	2-3-6	3-4-8	3-5-10	4-6-11	4-7-13	5-8-14	6-10-16	8-11-17	
		4-Way	3-5-11	5-7-13	6-9-14	7-11-16	8-12-17	9-13-18	12-14-20	13-16-22	
		3-Way	4-6-11	5-8-14	6-10-16	8-11-17	9-13-19	10-14-20	13-16-22	14-17-25	
		2-Way	4-6-12	6-8-16	7-10-18	8-12-19	10-15-21	11-16-22	14-18-25	16-19-27	
		1-Way NC	9-14-21	13-17-25	16-19-27	17-21-30	19-23-33	20-25-35	22-27-39	25-30-43	
CFM	420	560	700	840	975	1115	1395	1675			
Pt	0.019	0.033	0.052	0.075	0.101	0.132	0.206	0.297			
16"	Throw	4*-Way	2-3-7	3-4-9	4-5-11	4-7-13	5-8-15	6-9-16	7-11-18	9-13-20	
		4-Way	4-6-12	5-8-15	7-10-16	8-12-18	9-14-19	11-15-21	13-16-23	15-18-25	
		3-Way	4-7-13	6-9-16	7-11-18	9-13-20	10-15-21	12-16-23	15-18-26	16-20-28	
		2-Way	5-7-14	6-9-18	8-12-20	9-14-22	11-17-24	13-18-26	16-20-29	18-22-31	
		1-Way NC	10-16-24	15-20-28	18-22-31	20-24-34	21-26-37	23-28-40	26-31-44	28-34-49	

See Page PCD-139 for Series 7600 Performance Notes

Perforated Ceiling Diffusers



PCD

# PCD - Perforated Ceiling Diffusers

8/2006

## Series 7600 - Performance/Drop Face - Round Neck

Models 7600 (-8, -9), 7600-1 DF, 7600 AF (-8, -9), 7600 AL (-8)

Perforated Ceiling Diffusers



PCD

Listed Size	Neck Size Ak	fpm Neck Velocity Pv	300 0.006	400 0.010	500 0.016	600 0.022	700 0.031	800 0.040	1000 0.062	1200 0.090		
24" x 24"	6"	CFM Pt	60 0.015	80 0.026	100 0.041	120 0.060	135 0.075	155 0.099	195 0.157	235 0.229		
		Throw	4*-Way 4-Way 3-Way 2-Way 1-Way NC	1-1-3 1-2-3 1-2-4 3-4-7 4-5-7 -	1-2-3 1-2-5 2-3-5 4-5-8 5-6-9 -	1-2-4 2-3-5 2-4-5 5-6-8 6-7-10 -	2-3-4 2-3-6 3-4-6 5-7-9 6-7-11 <15	2-3-4 3-4-6 3-4-6 6-7-10 6-8-11 17	2-3-5 3-4-6 4-4-6 6-7-11 7-8-12 20	3-4-5 4-5-7 4-5-7 7-8-12 8-9-13 26	3-4-6 4-6-8 5-6-8 8-9-13 9-10-15 32	
		8"	CFM Pt	105 0.016	140 0.028	175 0.044	210 0.063	245 0.086	280 0.112	350 0.175	420 0.252	
			Throw	4*-Way 4-Way 3-Way 2-Way 1-Way NC	1-2-3 1-2-4 1-3-5 4-6-9 5-7-10 -	2-2-4 2-3-6 2-4-6 5-7-10 6-8-11 -	2-3-5 2-4-7 3-5-7 6-8-11 7-9-13 -	2-3-5 3-4-7 4-5-7 7-9-12 8-9-13 8-10-14 15	3-4-6 3-5-8 4-6-8 8-9-13 9-11-15 19	3-4-6 4-6-9 5-6-9 8-10-14 9-11-16 9-11-16 22	4-5-7 5-7-10 5-7-10 9-11-16 10-13-18 10-13-18 28	4-5-8 6-7-10 6-7-10 10-12-17 11-14-20 11-14-20 34
			10"	CFM Pt	165 0.017	220 0.030	275 0.047	325 0.066	380 0.090	435 0.118	545 0.186	655 0.268
				Throw	4*-Way 4-Way 3-Way 2-Way 1-Way NC	1-2-4 1-3-6 2-4-7 5-7-11 6-9-12 -	2-3-5 2-4-7 3-5-8 6-9-13 8-10-14 -	2-4-6 3-5-8 4-6-8 8-10-14 9-11-16 <15	3-4-7 4-6-9 5-6-9 9-11-15 10-12-17 10-12-17 16	3-5-7 4-6-10 5-7-10 10-12-17 11-13-19 11-13-19 21	4-5-8 5-7-11 6-8-11 10-13-18 12-14-20 12-14-20 24	5-6-9 6-8-12 7-8-12 11-14-20 13-16-22 13-16-22 31
	12"			CFM Pt	235 0.018	315 0.033	395 0.052	470 0.074	550 0.101	630 0.133	785 0.206	940 0.295
				Throw	4*-Way 4-Way 3-Way 2-Way 1-Way NC	1-3-5 1-3-7 2-4-8 6-8-13 7-10-15 -	2-3-7 3-4-9 4-6-9 8-11-15 9-12-17 -	3-4-7 4-6-10 5-7-10 9-12-17 11-14-19 <15	3-5-8 4-7-11 6-8-11 11-13-18 12-15-21 12-15-21 17	4-6-9 5-8-12 7-8-12 11-14-20 13-16-23 13-16-23 22	5-7-9 6-9-13 7-9-13 12-15-21 14-17-24 14-17-24 25	6-7-10 7-10-14 8-10-14 14-17-24 16-19-27 16-19-27 32
		14"		CFM Pt	320 0.017	430 0.031	535 0.048	640 0.068	750 0.094	855 0.122	1070 0.191	1285 0.276
				Throw	4*-Way 4-Way 3-Way 2-Way 1-Way NC	2-3-6 2-4-8 2-5-9 7-10-15 8-12-17 -	3-4-8 3-5-10 4-7-11 9-12-18 11-14-20 -	3-5-9 4-6-12 5-8-12 11-14-20 13-16-22 <15	4-6-9 5-8-13 7-9-13 12-15-21 13-16-23 14-17-24 18	5-7-10 6-9-14 8-10-14 13-16-23 15-19-26 15-19-26 23	5-8-11 7-10-15 9-11-15 14-18-25 16-20-28 16-20-28 27	7-9-12 9-12-17 10-12-17 16-20-28 18-22-31 18-22-31 34
			16"	CFM Pt	420 0.019	560 0.033	700 0.052	840 0.075	975 0.101	1115 0.132	1395 0.206	1675 0.297
				Throw	4*-Way 4-Way 3-Way 2-Way 1-Way NC	2-3-7 2-4-9 3-6-10 8-11-17 9-14-20 -	3-5-9 3-6-12 5-7-12 10-14-20 12-16-23 -	4-6-10 5-7-13 6-9-13 13-16-22 15-18-25 <15	5-7-11 6-9-15 7-10-15 14-17-25 16-20-28 16-20-28 20	5-8-12 7-10-16 9-11-16 15-19-26 17-21-30 17-21-30 24	6-9-12 8-12-17 10-12-17 16-20-28 19-23-32 19-23-32 29	8-10-14 10-13-19 11-13-19 18-22-32 21-25-36 21-25-36 36

See Page PCD-139 for Series 7600 Performance Notes

## Series 7600R Round Neck

### All models for Series 7600R

Nominal Neck Diameter	fpm Inlet Velocity Ps	300 -.01	400 -.02	500 -.03	600 -.04	700 -.05	800 -.06	900 -.08	1000 -.10
6	CFM	60	80	100	115	135	155	175	195
8	CFM	105	140	175	210	245	280	315	350
10	CFM	165	220	270	325	380	435	490	545
12	CFM	235	315	390	470	550	630	705	785
14	CFM	320	425	535	640	750	855	930	1070
16	CFM	420	560	700	835	975	1115	1255	1395
18	CFM	520	700	870	1045	1220	1395	1570	1740

### Performance Notes:

All data are tested in accordance with ANSI/ASHRAE 70-1991

### Definition of Units:

- CFM - Cubic feet per minute (air)
- fpm - Velocity of air stream in feet per minute
- Pv - Velocity pressure (inches of water column)
- Pt - Total pressure (inches of water column)
- Ps - Static pressure = Pt - Pv (inches of water column)
- Throw\* - Non-isothermal horizontal throw (supply air temperature 15°F colder than average room air temperature) values are for 150 fpm - 100 fpm - 50 fpm velocities
- Throw - Isothermal horizontal throw (supply air temperature the same as average room air temperature) values are for 150 fpm - 100 fpm - 50 fpm velocities
- NC - Noise criterion, sound pressure level. NC ratings are based on sound power level (Lw) RE: 10E-12 watts minus a 10 dB room attenuation in all octave bands

## Series 7600 - Specification

### Supply - Perforated Diffuser - Adjustable Neck Mounted Curved Blade Pattern Controllers - Round Neck/Series 7600

Steel	Aluminum Face - Steel Backpan	Aluminum
7600-1 - Surface Mounted	7600-1 AF - Surface Mounted	7600-6 AL - T-bar Lay-in
7600-1 DF - Surface Mounted-Dropped Face	7600-6 AF - T-bar Lay-in	7600-6 AL - Tegular T-bar
7600-6 - T-bar Lay-in	7600-8 AF - Tegular T-bar	
7600-8 - Tegular T-bar	7600-9 AF - Donn Finline	
7600-9 - Donn Finline		

Air Outlets shall be steel model 7600 or aluminum face, steel backpan model 7600-AF or all aluminum model 7600-AL manufactured by METALAIRES.

Units shall consist of a 51% free area perforated face with 3/16" diameter perforated holes on 1/4" staggered centers. The perforated face shall be removable allowing access to aluminum curved blade pattern with tension spring clips. Pattern controller blades shall be individually adjustable and allow the discharge pattern to be adjustable from vertical to horizontal. Pattern controller blades shall pivot in adjustable from vertical to horizontal. Pattern controller blades shall pivot in friction mounting retainers. Retainers shall hold the deflector blade position throughout the specified operating range of the device. Metal friction wires are not acceptable.

Outlets shall be available in 1, 2-way opposite, 2-way corner, 3, and 4-way directional air patterns.

### Return - Perforated Diffuser - Round Neck - 12" x 12"/24" x 24" Module/Series 7600

Steel	Aluminum Face - Steel Backpan	Aluminum
7600R-1 - Surface Mounted	7600R-1 AF - Surface Mounted	7600R-6 AL - T-bar Lay-in
7600R-1 DF - Surface Mounted-Dropped Face	7600R-6 AF - T-bar Lay-in	7600R-6 AL - Tegular T-bar
7600R-6 - T-bar Lay-in	7600R-8 AF - Tegular T-bar	
7600R-8 - Tegular T-bar	7600R-9 AF - Donn Finline	
7600R-9 - Donn Finline		

Air Inlets shall be steel model 7600R or aluminum face, steel backpan model 7600R-AF or all aluminum model 7600R-AL manufactured by METALAIRES.

Units shall consist of aluminum 51% free area perforated face with 3/16" diameter perforated holes on 1/4" staggered centers. Units shall be designed for use in ducted return or exhaust applications.

The perforated face shall be hinged allowing access to the inside of the packpan. Face shall be secured in place with tension spring clips.

The units shall be the size and quality as outline in the plans and specifications.

Units shall be designed to integrate into the specified ceiling systems.







## Series 7600 - Specification

### Optional Dampers and Accessories:

#### **Square to Round Transitions**

Units to have square to round transitions allowing installation with round ductwork.

#### **Butterfly Damper**

METALAIRES model BDS aluminum round butterfly type dampers shall be provided. Damper shall consist of two butterfly style blades that can be adjusted from full open to full closed. Damper shall be adjusted with a screw driver slot that can be assessed through the face of the diffuser.

#### **Radial Shutter Damper**

METALAIRES model RSD steel round radial shutter damper shall be provided. Damper shall consist of gang operated radial blades that slide perpendicular to air flow direction. The damper shall be adjusted from full open to full closed. Damper shall be adjusted with a screw driver slot that can be assessed through the face of the diffuser.

#### **Opposed Blade Damper**

METALAIRES model D3 aluminum or SD3 steel round opposed blade type dampers shall be provided. Damper shall consist of gang operated blades that can be adjusted from full open to full closed. Damper shall be adjusted with a screw driver slot that can be assessed through the face of the diffuser.

#### **Equalizing Grid**

METALAIRES model G3 aluminum round equalizing grid shall be provided. Equalizing grid shall consist of 1/2" x 1/2" x 1/2" aluminum cubed core mounting in an aluminum frame

### Performance Specification

The manufacturer shall provide published performance data. Data shall be tested in accordance to ANSI/ASHRAE Standard 70-1991.

### Paint Specification

Process shall be anodic electrodeposition using an anodic acrylic paint. Units shall undergo pre-treatment including a pressurized spray stage using an alkaline cleaner and a de-ionized water rinse.

Film Properties shall meet or exceed the following standards:

Property	Test Method	Performance
Film thickness		.8-1.0 mils
Film Cure		320 F @ 20 min
Gloss – 60 deg.	ASTM D523-89	70-80%
Pencil Hardness	ASTM D3363-92A	HB-H
Crosshatch Adhesion	ASTM D3359-95	4B-5B
Direct Impact	ASTM D2794-93	100 in.lbs. Min
Reverse Impact	ASTM D2794-93	60 in.lbs. Min.
Salt Spray	ASTM B117-95	48-96 Hours
Humidity	ASTM D1735-92	500 Hours
Water Soak	ASTM D870-92	250 Hours

# PCD - Perforated Ceiling Diffusers

## Series 7600 - Model Specification Guide

Supply Perforated Diffuser - Round Necks  
Adjustable Neck Mounted Pattern Controllers  
Series 7600

Model	Available Neck	Module	Air Pattern	Available Finishes	Available Options	
7600-1 - Flush Surface Mount 7600-1 DF - Flush Surface Mount - Drop Face 7600-1 AF - Flush Surface Mount - Aluminum Face	6" 8" 10" 12" 14" 16"	24" x 24"	Standard	Standard	G3	Equalizing Grid
			4W - 4-way	01 - White	BDS	Butterfly Damper
			Optional	Optional	RSD	Radial Shutter Damper
			1W - 1 Way	03 - Black	D3	Round Opposed Blade Damper - Aluminum
			2W - 2-Way Opposite	22 - Black Back Pan White Face		
			2C - 2 Way Corner	28 - Custom Color	SD3	Round Opposed Blade Damper - Steel
			3W - 3-Way			
			ST - Star Corner Blow			

Model	Available Neck	Module	Air Pattern	Available Finishes	Available Options	
7600-6 - T-bar Lay-in 7600-6 AF - T-bar Lay-in - Aluminum Face 7600-6 AL - T-bar Lay-in - All Aluminum 7600-8 - Tegular T-bar 7600-8 AF - Tegular T-bar - Aluminum Face 7600-8 AL - Tegular T-bar - All Aluminum 7600-9 - Donn Finline	6" 8" 10" 12" 14" 16"	24" x 24"	Standard	Standard	G3	Equalizing Grid
			4W - 4-way	01 - White	BDS	Butterfly Damper
			Optional	Optional	RSD	Radial Shutter Damper
			1W - 1 Way	03 - Black	D3	Round Opposed Blade Damper - Aluminum
			2W - 2-Way Opposite	22 - Black Back Pan White Face		
			2C - 2 Way Corner	28 - Custom Color	SD3	Round Opposed Blade Damper - Steel
			3W - 3-Way			
			ST - Star Corner Blow			

Return and Exhaust Perforated Diffuser - Round Necks  
Series 7600R

Model	Available Neck	Module	Available Finishes	Available Options	
7600R-1 - Flush Surface Mount 7600R-1 DF - Flush Surface Mount - Drop Face 7600R-1 AF - Flush Surface Mount - Aluminum Face	6" 8" 10" 12" 14" 16"	12" x 12" 24" x 24"	Standard	G3	Equalizing Grid
			01 - White	BDS	Butterfly Damper
			Optional	RSD	Radial Shutter Damper
			03 - Black	D3	Round Opposed Blade Damper - Aluminum
			22 - Black Back Pan White Face	SD3	Round Opposed Blade Damper - Steel
			28 - Custom Color		

Model	Available Neck	Module	Available Finishes	Available Options	
7600R-6 - T-bar Lay-in 7600R-6 AF - T-bar Lay-in - Aluminum Face 7600R-6 AL - T-bar Lay-in - All Aluminum 7600R-8 - Tegular T-bar 7600R-8 AF - Tegular T-bar - Aluminum Face 7600R-8 AL - Tegular T-bar - All Aluminum 7600R-9 - Donn Finline	6" 8" 10" 12" 14" 16"	12" x 12" 24" x 24"	Standard	G3	Equalizing Grid
			01 - White	BDS	Butterfly Damper
			Optional	RSD	Radial Shutter Damper
			03 - Black	D3	Round Opposed Blade Damper - Aluminum
			22 - Black Back Pan White Face	SD3	Round Opposed Blade Damper - Steel
			28 - Custom Color		

Perforated Ceiling Diffuser - Metric - Round Necks  
Series 7600 - T-bar Lay-in

Model	Available Neck	Module	Available Finishes	Available Options	
M7600-6 - Supply M7600R-6 - Return	6" 8"	600 x 600	Standard	G3	Equalizing Grid
			01 - White	BDS	Butterfly Damper
	10" 12" 14" 16"		Optional	RSD	Radial Shutter Damper
			03 - Black	D3	Round Opposed Blade Damper - Aluminum
			22 - Black Back pan White Face	SD3	Round Opposed Blade Damper - Steel
			28 - Custom Color		



# PCD - Perforated Ceiling Diffusers

8/2006

- ➔ Supply/Return Perforated Ceiling Diffusers ➔ Square Neck
- ➔ Neck Mounted Curved Blade Pattern Controllers

## Product Details

- ✦ The 7650 perforated supply diffuser has curved blade pattern controllers mounted in the neck of the diffuser. Pattern controllers are adjustable from a horizontal to vertical discharge pattern
- ✦ The hinged, fully removable face allow access to the pattern controllers
- ✦ Units are available in 1, 2-way opposite, 2-way corner, 3, and 4-way patterns. The 4-way core can be set for corner or side discharge patterns
- ✦ Border 6, T-bar Lay-in can be used in surface mounting applications by adding optional T-bar Plaster Frame (TBPf)
- ✦ Matching returns available: 7600R (round neck) 7650R Square neck
- ✦ The 7650 is an excellent choices for VAV applications

Series 7650	
7650	Steel Backpan & Face
7650 AF	Steel Backpan & Aluminum Face
7650 AL	Aluminum Backpan & Face

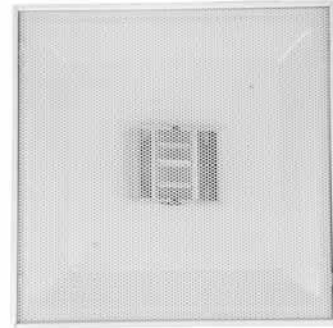

**Model 7650-6 4W Shown**  
Standard Finish: 01 White

Perforated Ceiling Diffusers



PCD

## Supply

Dimensions are in inches

### Supply - Square Neck - Adjustable - Surface Mount

- Model 7650-1 - Steel backpan & face
- Model 7650-1 DF - Steel backpan & face - drop face
- Model 7650-1 AF - Steel backpan & aluminum face

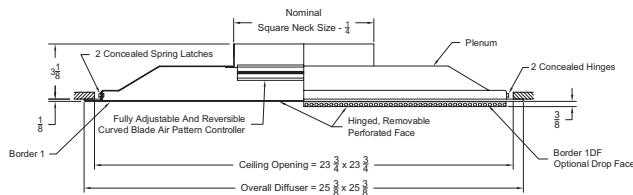

### Supply - Square Neck -Adjustable - T-bar Lay-in

- Model 7650-6 - Steel backpan & face
- Model 7650-6 AF - Steel backpan & aluminum face
- Model 7650-6 AL - Aluminum backpan & face

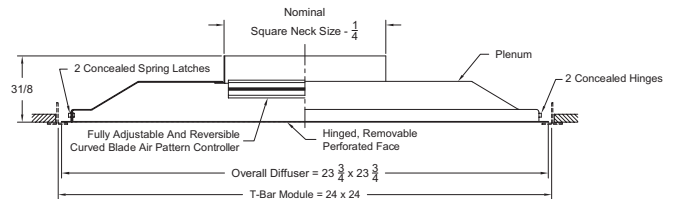

### Supply - Square Neck - Adjustable - Tegular T-bar

- Model 7650-8 - Steel backpan & face
- Model 7650-8 AF - Steel backpan & aluminum face
- Model 7650-8 AL - Aluminum backpan & face

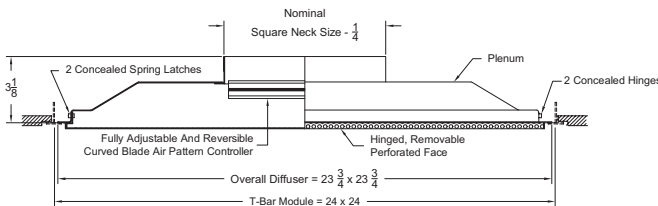

### Supply - Square Neck - Adjustable - Donn Fineline

- Model 7650-9 - Steel backpan & face
- Model 7650-9 AF - Steel backpan & aluminum face

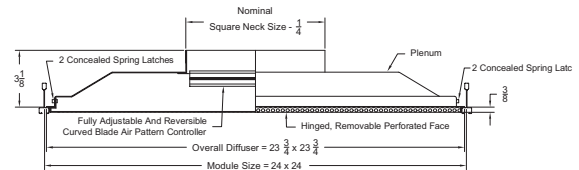

Available Neck Sizes (For All Models): 6 x 6, 8 x 8, 10 x 10, 12 x 12, 14 x 14 and 16 x 16

# PCD - Perforated Ceiling Diffusers



## Return

### Return - Square Neck - Adjustable - Surface Mount

- Model 7650R-1 - Steel backpan & face (24" x 24")
- Model 7650R-1 DF - Steel backpan & drop face - (24" x 24")
- Model 7650R-1 AF - Steel backpan & aluminum face (24" x 24")

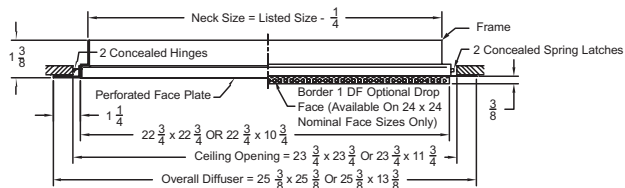

Available For 24 x 24 Ceiling Openings. 24 x 24 Return Available With 22 x 22 Neck Size.  
24 x 12 Return Available With 22 x 10 Neck Size Only.

### Return - Square Neck - Adjustable - Surface Mount

- Model 7650R-1 - Steel backpan & face (12" x 12")
- Model 7650R-1 DF - Steel backpan & face - drop face (12" x 12")
- Model 7650R-1 AF - Steel backpan & aluminum face (12" x 12")

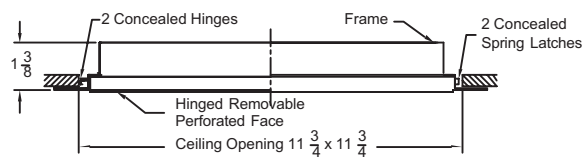

### Return - Square Neck - Adjustable - T-bar Lay-in

- Model 7650R-6 - Steel backpan & face (24" x 24")
- Model 7650R-6 AF - Steel backpan & aluminum face (24" x 24")
- Model 7650R-6 AL - Aluminum backpan & face (24" x 24")

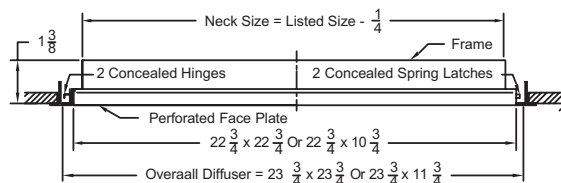

Available For 24 x 24 And 24 x 12 T-Bar Lay-In Ceiling Grids.  
24 x 24 Return Available With 22 x 22 Neck Size.  
24 x 12 Return Available With 22 x 10 Neck Size Only.

### Return - Square Neck - Adjustable - T-bar Lay-in

- Model 7650R-6 - Steel backpan & face (12" x 12")
- Model 7650R-6 AF - Steel backpan & aluminum face (12" x 12")
- Model 7650R-6 AL - Aluminum backpan & face (12" x 12")

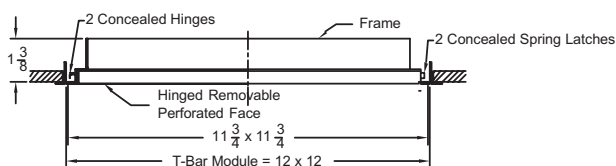

### Return - Square Neck - Adjustable - Tegrular T-bar

- Model 7650R-8 - Steel backpan & face (24" x 24")
- Model 7650R-8 AF - Steel backpan & aluminum face (24" x 24")
- Model 7650R-8 AL - Aluminum backpan & face (24" x 24")

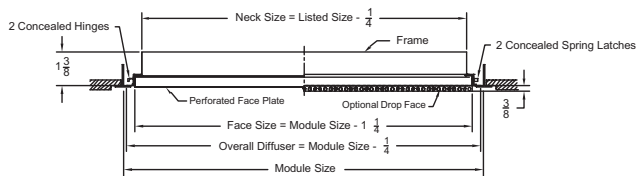

### Return - Square Neck - Adjustable - Donn Finline

- Model 7650R-9 - Steel backpan & face
- Model 7650R-9 AF - Steel backpan & aluminum face

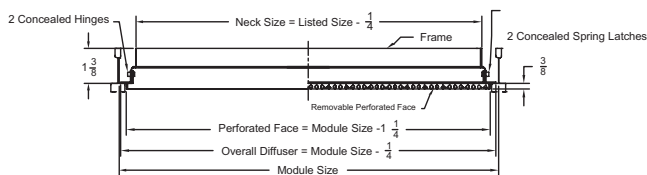

# PCD - Perforated Ceiling Diffusers

8/2006

Perforated Ceiling Diffusers



PCD

**Metric**

*Dimensions are in millimeters*

**Supply - Square Neck - Adjustable - T-bar Lay-in**  
 Model M7650-6 - *Steel backpan & face*  
 Model M7650-6 AF - *Steel backpan & aluminum face*  
 Model M7650-6 AL - *Aluminum backpan & face*

**Return - Square Neck - Adjustable - T-bar Lay-in**  
 Model M7650R-6 - *Steel backpan & face*  
 Model M7650R-6 AF - *Steel backpan & aluminum face*  
 Model M7650R-6 AL - *Aluminum backpan & face*

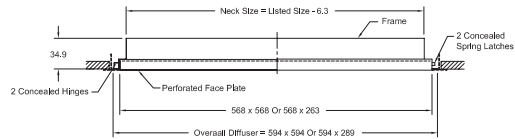
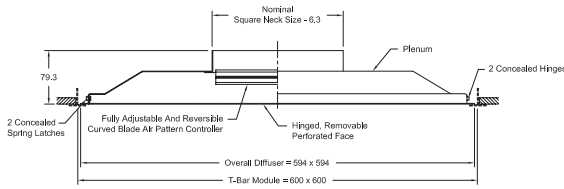

**Notes for Models 7650 (-1, -6, -8, -9), 7650-1 DF, 7650 AF (-1, -6, -8, -9), 7650 AL (-6, -8)**

1. Available Finishes	2. Available Accessories	3. Construction Details
<p><b>Standard Finish:</b> 01 White</p> <p><b>Optional Finish</b> 02 Aluminum paint 03 Black 22 (BBP) Black back pan/white face 28 Custom color</p>	<p><b>All accessories shipped unattached</b></p> <p><b>Square Necks:</b>                      OBD - Opposed blade damper - Steel . . . . .334                      OBDA - Opposed blade damper - Aluminum .334                      L9 - Equalizing grid . . . . .334</p> <p><b>Round Neck:</b>                      G3 - Round equalizing grid . . . . .337                      BDS - Butterfly damper . . . . .335                      RSD - Radial Shutter damper . . . . .336</p>	<ul style="list-style-type: none"> <li>• Pattern controllers are mounted on the back side of the perforated face and can be specified for 1, 2, 3 or 4 way pattern</li> <li>• Series 7650 have 3/16" diameters holes on 1/4" staggered centers</li> </ul>

**Notes for Models 7650R (-1, -6, -8, -9), 7650R-1 DF, 7650R AF (-1, -6, -8, -9), 7650R AL (-6, -8)**

1. Available Finishes	2. Available Accessories	3. Construction Details
<p><b>Standard Finish:</b> 01 White</p> <p><b>Optional Finish</b> 02 Aluminum paint 03 Black 22 (BBP) Black back pan/white face 28 Custom color</p>	<p><b>All accessories shipped unattached</b></p> <p>OBD - Opposed blade damper - Steel . . . . .334                      OBDA - Opposed blade damper - Aluminum .334</p>	<ul style="list-style-type: none"> <li>• Available only in listed sizes</li> <li>• Series 7650R have 3/16" diameters holes on 1/4" staggered centers</li> </ul>

# PCD - Perforated Ceiling Diffusers

## Series 7650 - Performance/Flush Face - Square Neck

Models 7650 (-1, -6), 7650 AF (-1, -6), 7650 AL (-6)

Listed Size	Neck Size	fpm Neck Velocity Pv	300 0.006	400 0.010	500 0.016	600 0.022	700 0.031	800 0.040	1000 0.040	1200 0.090
24" x 24"	6" x 6"	CFM Pt	75 0.017	100 0.031	125 0.048	150 0.070	175 0.095	200 0.124	250 0.194	300 0.279
		Throw	4*-Way 4-Way 3-Way 2-Way 1-Way NC	1-1-3 2-3-5 2-3-6 2-3-6 4-7-10 -	1-2-4 2-3-6 2-4-7 3-4-8 6-8-12 -	2-2-5 3-4-7 3-5-8 3-5-9 8-9-13 <15	2-3-6 3-5-8 4-6-8 4-6-9 8-10-15 16	2-3-6 3-5-8 4-6-8 4-6-9 5-7-10 8-10-15 21	2-4-7 5-6-9 5-7-10 5-8-11 10-12-17 25	3-5-8 6-7-10 6-8-11 7-9-12 11-13-19 30
	8" x 8"	CFM Pt	135 0.020	180 0.036	220 0.054	265 0.079	310 0.108	355 0.141	445 0.222	535 0.321
		Throw	4*-Way 4-Way 3-Way 2-Way 1-Way NC	1-2-4 2-3-7 2-4-7 3-4-8 6-9-14 -	2-2-5 3-5-8 3-5-9 4-5-10 8-11-16 -	2-3-6 4-6-9 4-6-10 4-7-11 10-12-18 <15	2-4-7 5-7-10 5-7-11 5-8-12 11-14-19 18	3-4-8 5-8-11 6-9-12 6-9-13 12-15-21 23	3-5-9 6-8-12 7-9-13 7-10-14 13-16-22 28	4-6-10 8-9-13 8-10-14 9-11-16 14-18-25 34
	10" x 10"	CFM Pt	210 0.023	280 0.040	345 0.061	415 0.089	485 0.089	555 0.159	695 0.249	835 0.359
		Throw	4*-Way 4-Way 3-Way 2-Way 1-Way NC	2-2-5 3-4-9 3-5-9 3-5-10 7-12-17 -	2-3-6 4-6-10 4-6-11 4-7-13 10-14-20 -	3-4-8 5-7-12 5-8-13 6-8-14 13-16-22 <15	3-5-9 6-8-13 6-9-14 7-10-16 14-17-24 20	4-5-11 6-8-13 7-11-15 8-12-17 15-18-26 26	4-6-11 8-10-15 8-11-16 9-13-18 16-20-28 29	5-8-13 9-12-16 10-13-18 11-14-20 18-22-31 36
	12" x 12"	CFM Pt	300 0.023	400 0.040	500 0.063	600 0.090	700 0.123	800 0.160	1000 0.250	1200 0.360
		Throw	4*-Way 4-Way 3-Way 2-Way 1-Way NC	2-3-6 3-5-10 4-6-11 4-6-12 9-14-21 -	2-4-7 5-7-12 5-7-14 5-8-15 12-17-24 -	3-5-9 6-9-14 6-9-15 7-10-17 15-19-27 <15	4-6-11 7-10-15 7-11-17 8-12-19 17-21-29 21	4-6-13 8-12-16 9-13-18 9-14-20 18-22-31 26	5-7-14 9-12-18 10-14-19 11-15-22 19-24-34 31	6-9-15 11-14-20 12-15-22 13-17-24 22-27-38 38
	14" x 14"	CFM Pt	410 0.023	545 0.040	680 0.062	815 0.089	950 0.121	1090 0.159	1360 0.248	1630 0.356
		Throw	4*-Way 4-Way 3-Way 2-Way 1-Way NC	2-3-6 4-6-12 4-7-13 5-7-14 10-16-24 -	3-4-9 5-8-15 6-9-16 6-9-18 14-20-28 -	4-5-11 7-10-16 7-11-18 8-12-20 18-22-31 <15	4-6-13 8-12-18 9-13-20 9-14-22 20-24-34 21	5-7-15 9-14-19 10-15-21 11-16-24 21-26-37 28	6-9-16 11-15-21 12-16-23 12-18-25 23-28-39 33	7-11-18 13-16-23 14-18-25 16-20-28 25-31-44 41
	16" x 16"	CFM Pt	535 0.027	710 0.047	890 0.074	1070 0.108	1245 0.146	1425 0.191	1780 0.298	2135 0.428
		Throw	4*-Way 4-Way 3-Way 2-Way 1-Way NC	2-4-7 4-7-14 5-7-15 5-8-16 12-18-27 -	3-5-10 6-9-17 7-10-18 7-11-20 16-22-32 -	4-6-12 8-11-19 8-12-20 9-13-23 20-25-35 15	5-7-15 9-14-20 10-15-22 11-16-25 22-27-39 23	6-9-17 11-16-22 12-17-24 11-16-25 24-30-42 30	7-10-18 12-17-23 13-18-26 14-20-29 26-32-45 35	8-12-20 15-19-26 16-20-29 18-23-32 29-35-50 42

See Page PCD-147 for Series 7650 Performance Notes

Perforated Ceiling Diffusers



PCD

# PCD - Perforated Ceiling Diffusers

8/2006

## Series 7650 - Performance/Drop Face - Square Neck

Models 7600 (-8, -9), 7600-1 DF, 7600 AF (-8, -9), 7600 AL (-8)

Listed Size	Neck Size	fpm Neck Velocity Pv	300 0.006	400 0.010	500 0.016	600 0.022	700 0.031	800 0.040	1000 0.040	1200 0.090	
24" x 24"	6" x 6"	CFM Pt	75 0.017	100 0.031	125 0.048	150 0.069	175 0.093	200 0.122	250 0.191	300 0.275	
		Throw	4*-Way	1-1-3	1-2-4	2-2-4	2-3-5	2-3-5	3-4-5	3-4-6	4-5-6
			4-Way	1-2-4	1-3-5	2-3-6	3-4-6	3-4-7	3-5-7	4-6-8	5-6-9
			3-Way	1-2-4	2-3-5	3-4-6	3-4-6	4-5-7	4-5-7	5-6-8	5-6-9
			2-Way	3-5-7	4-6-8	5-7-9	6-7-10	6-8-11	7-8-12	8-9-13	8-10-15
			1-Way	4-6-8	5-7-10	6-8-11	7-8-12	7-9-13	8-10-14	9-11-15	10-12-17
	NC	-	<15	16	23	27	30	34	38		
	8" x 8"	CFM Pt	135 0.020	180 0.036	220 0.054	265 0.079	310 0.108	355 0.141	445 0.222	535 0.321	
		Throw	4*-Way	1-2-4	2-3-5	2-3-5	3-4-6	3-5-7	3-5-7	4-6-8	5-6-9
			4-Way	1-2-5	2-3-7	3-4-8	3-5-8	4-6-9	4-7-10	6-8-11	7-8-12
			3-Way	2-3-6	3-4-7	3-5-8	4-6-8	5-6-9	6-7-10	6-8-11	7-8-12
			2-Way	4-6-10	6-8-11	7-9-13	8-10-14	9-11-15	9-11-16	10-13-18	11-14-20
			1-Way	5-8-11	7-9-13	8-10-14	9-11-16	10-12-17	10-13-18	12-14-20	13-16-22
	NC	-	<15	17	25	30	34	38	41		
	10" x 10"	CFM Pt	210 0.023	280 0.040	345 0.061	415 0.089	485 0.121	555 0.158	695 0.248	835 0.358	
		Throw	4*-Way	1-2-5	2-3-6	3-4-7	3-5-8	4-6-8	4-6-9	5-7-10	6-8-11
			4-Way	1-3-6	2-4-8	3-5-9	4-6-10	5-7-11	6-8-12	7-9-13	8-10-15
			3-Way	2-4-7	4-5-9	4-7-9	5-7-10	6-8-11	7-8-12	8-9-13	8-10-15
			2-Way	5-8-12	7-10-14	9-11-16	10-12-17	11-13-19	12-14-20	13-16-22	14-17-25
			1-Way	7-10-14	9-11-16	10-13-18	11-14-20	12-15-21	13-16-23	15-18-25	16-20-28
	NC	-	-	18	26	32	36	41	44		
	12" x 12"	CFM Pt	300 0.023	400 0.040	500 0.063	600 0.090	700 0.123	800 0.160	1000 0.250	1200 0.360	
		Throw	4*-Way	2-3-6	3-4-7	3-5-8	4-6-9	5-7-10	5-7-10	7-8-12	7-9-13
			4-Way	2-4-8	3-5-10	4-6-11	5-8-12	6-9-13	7-10-14	8-11-16	10-12-18
3-Way			2-5-9	4-6-10	5-8-11	6-9-12	7-10-13	8-10-14	9-11-16	10-12-18	
2-Way			6-10-15	8-12-17	11-13-19	12-15-21	13-16-22	14-17-24	15-19-27	17-21-29	
1-Way			8-12-17	10-14-19	12-15-22	14-17-24	15-18-25	16-19-27	18-22-30	19-24-33	
NC	-	-	21	29	35	39	43	46			
14" x 14"	CFM Pt	410 0.024	545 0.043	680 0.067	815 0.096	955 0.131	1090 0.171	1360 0.266	1635 0.385		
	Throw	4*-Way	2-3-7	3-5-9	4-6-10	5-7-11	5-8-11	6-9-12	8-10-14	9-11-15	
		4-Way	2-4-9	3-6-12	5-7-13	6-9-15	7-10-16	8-12-17	10-13-19	12-15-21	
		3-Way	3-6-10	5-7-12	6-9-13	7-10-15	9-11-16	10-12-17	11-13-19	12-15-21	
		2-Way	7-11-17	10-14-20	12-16-22	14-17-24	15-19-26	16-20-28	18-22-31	20-24-34	
		1-Way	9-14-19	12-16-22	14-18-25	16-19-27	17-21-30	18-22-32	20-25-35	22-27-39	
NC	-	-	21	30	37	41	46	49			
16" x 16"	CFM Pt	535 0.027	710 0.047	890 0.074	1065 0.107	1245 0.146	1420 0.190	1780 0.298	2135 0.428		
	Throw	4*-Way	2-4-8	3-5-10	4-7-11	5-8-12	6-9-13	7-10-14	9-11-16	10-12-17	
		4-Way	2-5-10	4-7-13	6-8-15	7-10-17	8-12-18	9-13-19	11-15-21	13-17-24	
		3-Way	3-6-12	6-8-14	7-11-15	8-12-17	10-13-18	11-14-19	12-15-21	14-17-24	
		2-Way	9-13-20	11-16-23	14-18-25	16-20-28	17-21-30	18-23-32	21-25-36	23-28-39	
		1-Way	10-16-22	14-18-26	17-20-29	18-22-31	20-24-34	21-26-36	23-29-41	26-31-44	
NC	-	-	22	31	38	42	48	52			

See Page PCD-147 for Series 7650 Performance Notes

Perforated Ceiling Diffusers



PCD



## Series 7650R - Performance

### All models for Series 7650R

Nominal Neck Size	fpm Inlet Velocity	300	400	500	600	700	800	900	1000
		PS	-0.08	-0.15	-0.2	-0.3	-0.5	-0.6	-0.8
6" x 6"	CFM	75	100	120	150	175	200	225	250
8" x 8"	CFM	130	175	220	265	310	350	400	445
10" x 10"	CFM	210	275	345	415	485	555	625	695
12" x 12"	CFM	300	400	500	600	700	800	900	1000
14" x 14"	CFM	410	545	680	815	950	1090	1225	1360
16" x 16"	CFM	530	710	885	1060	1240	1415	1600	1770
22" x 22"	CFM	1010	1345	1680	2015	2350	2690	3025	3360

### Performance Notes:

All data are tested in accordance with ANSI/ASHRAE 70-1991

### Definition of Units:

- CFM** - Cubic Feet per Minute (air)
- fpm** - Velocity of air stream in Feet Per Minute
- Pv** - Velocity pressure (inches of water column)
- Pt** - Total pressure (inches of water column)
- Ps** - Static pressure = Pt - Pv (inches of water column)
- Throw\*** - Non-isothermal horizontal throw (supply air temperature 15°F colder than average room air temperature) values are for 150 fpm - 100 fpm - 50 fpm velocities
- Throw** - Isothermal horizontal throw (supply air temperature the same as average room air temperature) values are for 150 fpm - 100 fpm - 50 fpm velocities
- NC** - Noise criterion, sound pressure level. NC ratings are based on sound power level (Lw) RE: 10E-12 watts minus a 10 dB room attenuation in all octave bands

## Series 7650 - Specification

### Supply - Perforated Diffuser - Square Neck - Adjustable Neck Mounted Pattern Controller/Series 7650

<b>Steel</b>	<b>Aluminum Face - Steel Backpan</b>	<b>Aluminum</b>
7650-1 - Surface Mounted	7650-1 AF - Surface Mounted	7650-6 AL - T-bar Lay-in
7650-1 DF - Surface Mounted-Dropped Face	7650-6 AF - T-bar Lay-in	7650-6 AL - Tegular T-bar
7650-6 - T-bar Lay-in	7650-8 AF - Tegular T-bar	
7650-8 - Tegular T-bar	7650-9 AF - Donn Finline	
7650-9 - Donn Finline		

Air Outlets shall be steel model 7650 or aluminum face, steel backpan model 7650-AF or all aluminum model 7650-AL manufactured by METALAIRES.

Units shall consist of a 51% free area perforated face with 3/16" diameter perforated holes on 1/4" staggered centers. The perforated face shall be removable allowing access to aluminum curved blade pattern controller mounted into the neck of the diffusers. Face shall be secured in place with tension spring clips. Pattern controller blades shall be individually adjustable and allow the discharge pattern to be adjustable from vertical to horizontal. Pattern controller blades shall pivot in friction mounting retainers. Retainers shall hold the deflector blade position throughout the specified operating range of the device. Metal friction wires are not acceptable.

Outlets shall be available in 1, 2 way opposite, 2 way corner, 3, and 4 way directional air patterns.

The units shall be the size and quantity as outline in the plans and specifications.

Units shall be designed to integrate into the specified ceiling system.

### Return - Perforated Diffuser - Square Neck /Series 7650R

<b>Steel</b>	<b>Aluminum Face - Steel Backpan</b>	<b>Aluminum</b>
7650R-1 - Surface Mounted	7650R-1 AF - Surface Mounted	7650R-6 AL - T-bar Lay-in
7650R-1 DF - Surface Mounted-Dropped Face	7650R-6 AF - T-bar Lay-in	7650R-8 AL - Tegular T-bar
7650R-6 - T-bar Lay-in	7650R-8 AF - Tegular T-bar	
7650R-8 - Tegular T-bar	7650R-9 AF - Donn Finline	
7650R-9 - Donn Finline		

Air Inlets shall be steel model 7650R or aluminum face, steel backpan model 7650R-AF or all aluminum model 7650R-AL manufactured by METALAIRES.

Units shall consist of aluminum 51% free area perforated face with 3/16" diameter perforated holes on 1/4" staggered centers. Units shall be designed for use in ducted return or exhaust applications.

The perforated face shall be hinged allowing access to the inside of the packpan. Face shall be secured in place with tension spring clips.

The units shall be the size and quantity as outline in the plans and specifications.

Units shall be designed to integrate into the specified ceiling system.





## Square Neck Options and Accessories

### Opposed Blade Damper

METALAIRE model OBDA aluminum or OBD steel round opposed blade type dampers shall be provided. Damper shall consist of gang operated blades that can be adjusted from full open to full closed. Damper shall be adjusted with a screw driver slot accessible by opening the face of the diffuser.

### Equalizing Grid

METALAIRE model L9 aluminum square equalizing grid shall be provided. Equalizing grid shall consist aluminum blades mounting in an aluminum frame.

## Performance Specification

The manufacturer shall provide published performance data. Data shall be tested in accordance to ANSI/ASHRAE Standard 70-1991.

## Paint Specification

Process shall be anodic electrodeposition using an anodic acrylic paint. Units shall undergo pre-treatment including a pressurized spray stage using an alkaine cleaner and a de-ionized water rinse.

Film Properties shall meet or exceed the following standards:

Property	Test Method	Performance
Film thickness		.8-1.0 mils
Film Cure		320 F @ 20 min
Gloss – 60 deg.	ASTM D523-89	70-80%
Pencil Hardness	ASTM D3363-92A	HB-H
Crosshatch Adhesion	ASTM D3359-95	4B-5B
Direct Impact	ASTM D2794-93	100 in.lbs. Min
Reverse Impact	ASTM D2794-93	60 in.lbs. Min.
Salt Spray	ASTM B117-95	48-96 Hours
Humidity	ASTM D1735-92	500 Hours
Water Soak	ASTM D870-92	250 Hours

## Series 7650 - Model Specification Guide

### Supply - Perforated Supply Diffuser - Square Necks Adjustable Neck Mounted Pattern Controllers Series 7650

Model	Available Neck	Module	Air Pattern	Available Finishes	Available Options	
7650-1 - Flush Surface Mount 7650-1 DF - Flush Surface Mount - Drop Face 7650-1 AF - Flush Surface Mount - Aluminum Face	6" x 6" 8" x 8" 10" x 10" 12" x 12" 14" x 14" 15" x 15" 16" x 16" 18" x 18"	24" x 24"	<b>Standard</b>	<b>Standard</b>	OBD	Opposed Blade Damper - Steel
			4W - 4-way	01 - White	OBDA	Opposed Blade Damper - Aluminum
			<b>Optional</b>	<b>Optional</b>	L9	Equalizing Grid
			1W - 1 Way	03 - Black		
			2W - 2-Way Opposite	22 - Black Back Pan White Face		
			2C - 2 Way Corner	28 - Custom Color		
			3W - 3-Way			
			ST - Star Corner Blow			

Model	Available Neck	Module	Air Pattern	Available Finishes	Available Options	
7650-6 - T-bar Lay-in 7650-6 AF - T-bar Lay-in - Aluminum Face 7650-6 AL - T-bar Lay-in - All Aluminum 7650-8 - Tegular T-bar 7650-8 AF - Tegular T-bar - Aluminum Face 7650-8 AL - Tegular T-bar - All Aluminum 7650-9 - Donn Finline	6" x 6" 8" x 8" 10" x 10" 12" x 12" 14" x 14" 15" x 15" 16" x 16"	24" x 24"	<b>Standard</b>	<b>Standard</b>	OBD	Opposed Blade Damper - Steel
			4W - 4-way	01 - White	OBDA	Opposed Blade Damper - Aluminum
			<b>Optional</b>	<b>Optional</b>	L9	Equalizing Grid
			1W - 1 Way	03 - Black		
			2W - 2-Way Opposite	22 - Black Back Pan White Face		
			2C - 2 Way Corner	28 - Custom Color		
			3W - 3-Way			
			ST - Star Corner Blow			

# PCD - Perforated Ceiling Diffusers

## Series 7650 - Model Specification Guide

Return and Exhaust - Perforated Supply diffuser - Square Necks  
Series 7650R

Model	Available Neck	Module	Available Finishes	Available Options	
7650R-1 - Flush Ceiling Mount 7650R-1 DF - Flush Ceiling Mount - Drop Face 7650R-1 AF - Flush Ceiling Mount - Aluminum Face	6" x 6" 8" x 8" 10" x 10" 12" x 12" 14" x 14" 15" x 15" 16" x 16" 18" x 18"	12" x 12" 24" x 24"	Standard	OBD	Opposed Blade Damper - Steel
			01 - White	OBDA	Opposed Blade Damper - Aluminum
			Optional	L9	Equalizing Grid
			03 - Black		
			22 - Black Back Pan White Face		
			28 - Custom Color		

Model	Available Neck	Module	Available Finishes	Available Options	
7650R-6 - T-bar Lay-in 7650R-6 AF - T-bar Lay-in - Aluminum Face 7650R-6 AL - T-bar Lay-in - All Aluminum 7650R-8 - Tegular T-bar 7650R-8 AF - Tegular T-bar - Aluminum Face 7650R-8 AL - Tegular T-bar - All Aluminum 7650R-9 - Donn Finline	6" x 6" 8" x 8" 10" x 10" 12" x 12" 14" x 14" 15" x 15" 16" x 16"	12" x 12" 24" x 24"	Standard	OBD	Opposed Blade Damper - Steel
			01 - White	OBDA	Opposed Blade Damper - Aluminum
			Optional	L9	Equalizing Grid
			03 - Black		
			22 - Black Back Pan White Face		
			28 - Custom Color		

Perforated Ceiling Diffuser - Metric - Round Necks  
Series 7600 - T-bar Lay-in

Model	Available Neck	Module	Available Finishes	Available Options	
M7650-6 - Supply M7650R-6 - Return	6" x 6" 8" x 8"	600mm x 600mm	Standard	G3	Equalizing Grid
			01 - White	BDS	Butterfly Damper
Optional	RSD		Radial Shutter Damper		
03 - Black					
22 - Black Back pan White Face					
28 - Custom Color					
	10" x 10" 12" x 12" 14" x 14" 15" x 15" 16" x 16"				



# PCD - Perforated Ceiling Diffusers

8/2006

➔ Supply Diffuser ➔ Perforated Face ➔ Modular Core ➔ Series 7900

## Product Details

- ★ The series 7900 is an aluminum, perforated modular core supply diffuser. Modular cores can be field adjusted for 1-way, 2-way opposite, 2-way corner, 3-way, and 4-way discharge air patterns
- ★ The perforated face is secured with spring clips making removal and access to the modular core pattern controllers easy
- ★ Border type 6 can be used in surface mounting applications by adding optional T-bar plaster frame (TBPF)
- ★ Matching returns available: 7900R
- ★ The series 7900 is an excellent choice for VAV applications



**Model 7900-6 Shown**

Standard Finish: 01 White

Dimensions are in inches

### Perforated Modular Core Supply Diffusers - Square Neck 1 or 4 Core - Surface Mount Model 7900-1

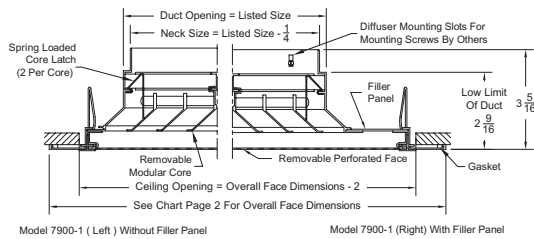

### Perforated Modular Core Supply Diffusers - Square Neck 1 or 4 Core - T-bar Lay-in - 24" x 24" Grid Size Only Model 7900-6

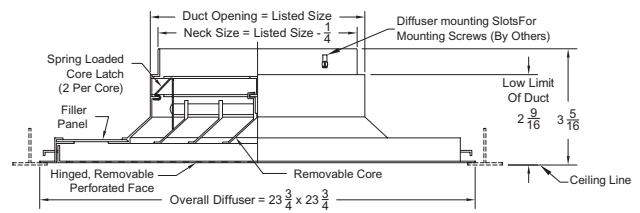

### Perforated Modular Core Supply Diffusers - Square Neck 1 or 4 Core - T-bar Lay-in - All Grid Sizes Except 24" x 24" Model 7900-6

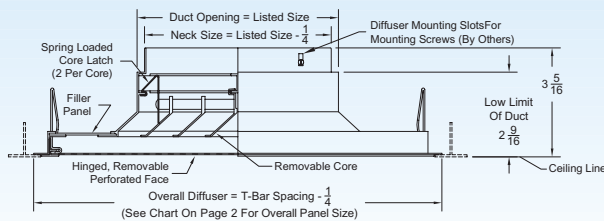

# PCD - Perforated Ceiling Diffusers



**Perforated Modular Core Supply Diffusers - Square Neck**  
**1 or 4 Core - Tegular T-bar**  
 Model 7900-8

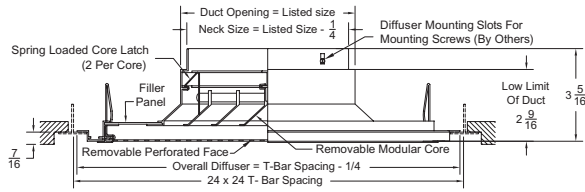

Air Patterns - Perforated Modular Core Ceiling Diffusers				
One Way	Two Way Corner	Two Way Opposite	Three Way	Four Way

1. Available Finishes	2. Available Accessories	3. Construction Details
<p><b>Standard Finish:</b>                      01 White</p> <p><b>Optional Finish</b>                      03 Black                      22 (BBP) Black back pan/white face and frame                      28 Custom color</p>	<p><b>Square Neck:</b>                      OBD - Opposed blade damper - Steel .....334                      OBDA - Opposed blade damper - Aluminum .....334                      L9 - Equalizing grid .....334                      TR DEEP - Square to round transition - deep .....338</p> <p><b>Round Neck:</b>                      G3 - Equalizing grid .....337                      BDS - Butterfly damper .....335                      RSD - Radial Shutter damper .....336</p>	<p>• Series 7900 have 3/16" diameter holes on 1/4" staggered centers</p>

# PCD - Perforated Ceiling Diffusers

8/2006

## Series 7900 - Performance (4 Core Supply)

All models for Series 7900 (-1, -6, -8)

Single Core Size (Inches)	Single Core Area (Sq. Ft)	Ak Effective Area (Sq. Ft.)	Neck Outlet Vel Pt	200 310 0.020	300 460 0.045	400 615 0.080	500 770 0.125	600 925 0.180	700 1080 0.245
3" X 3"	0.063	0.028	CFM THROW NC	13 1-3 <20	19 1-4 <20	25 2-6 <20	32 3-9 21	38 4-12 27	44 5-14 31
4" X 4"	0.111	0.049	CFM THROW NC	22 1-3 <20	33 2-6 <20	44 3-9 <20	56 4-12 24	67 5-15 29	78 6-18 34
5" X 5"	0.174	0.078	CFM THROW NC	35 1-3 <20	52 2-7 <20	70 3-9 20	87 5-15 26	104 7-20 31	122 8-23 36
6" X 6"	0.250	0.111	CFM THROW NC	50 2-6 <20	75 2-8 <20	100 4-12 21	125 6-18 27	150 12-24 33	175 10-28 37
7" X 7"	0.340	0.151	CFM THROW NC	68 2-6 <20	102 3-9 <20	136 5-15 23	170 7-21 28	204 10-27 34	238 11-33 38
8" X 8"	0.445	0.198	CFM THROW NC	89 2-6 <20	133 4-12 <20	178 6-18 25	222 8-24 30	267 10-30 35	311 12-36 40
9" X 9"	0.562	0.249	CFM THROW NC	112 2-6 <20	169 4-13 <20	225 6-18 25	281 9-27 31	337 12-35 36	393 14-42 41
10" X 10"	0.695	0.309	CFM THROW NC	139 2-6 <20	208 4-14 <20	278 6-18 26	347 10-30 32	416 14-40 37	486 16-46 42
11" X 11"	0.840	0.373	CFM THROW NC	168 2-7 <20	252 4-14 <20	336 7-20 27	420 11-27 33	504 15-43 38	588 17-49 43
12" X 12"	1.000	0.444	CFM THROW NC	200 2-8 <20	300 4-14 20	400 8-22 28	500 12-24 35	600 16-46 40	700 18-52 45

See Page PCD-153 for Series 7900 Performance Notes

Perforated Ceiling Diffusers



PCD

# PCD - Perforated Ceiling Diffusers

## Series 7900 - Performance (Single Core Supply)

All models for Series 7900 (-1, -6, -8)

Listed Size & Neck Area Sq. Ft.	Effective Sq. Ft.	Vn Neck Velocity fpm Vk Outlet Velocity fpm Pt Total Pressure Side Designation	300		400		500		600		700		
			A	B	A	B	A	B	A	B	A	B	
6" X 6" 0.25	0.162	CFM NC	50 <20		75 <20		100 21		125 27		150 33		
		Throw	4-Way	1-3		1-4		2-6		3-9		4-12	
			3-Way	1-3 2-4		1-4 2-6		2-6 3-8		3-9 4-13		4-12 6-17	
2-Way	2-4		2-6		3-8		4-13		6-17		12-24		
1-Way	2-6		2-8		4-12		6-18						
8" x 8" 0.44	0.288	CFM NC	90 <20		130 <20		175 25		220 30		265 35		
		Throw	4-Way	1-3		2-6		3-9		4-12		5-15	
			3-Way	1-3 2-4		2-6 3-8		3-9 4-13		4-12 6-17		5-15 7-21	
2-Way	2-4		3-8		4-13		6-17		7-21		10-30		
1-Way	2-6		4-12		6-18		8-24						
10" x 10" 0.69	.0450	CFM NC	140 <20		205 <20		275 26		345 32		415 37		
		Throw	4-Way	1-3		2-7		3-9		5-15		7-20	
			3-Way	1-3 2-4		2-7 3-10		3-9 4-13		5-15 7-21		7-20 10-28	
2-Way	2-4		3-10		4-13		7-21		10-28		14-40		
1-Way	2-6		4-14		6-18		10-30		14-40				
12" x 12" 1.00	0.648	CFM NC	200 <20		300 20		400 28		500 35		600 40		
		Throw	4-Way	1-4		2-7		4-11		6-17		8-23	
			3-Way	1-4 2-6		2-7 3-10		4-11 6-16		6-17 8-24		8-23 11-32	
2-Way	2-6		3-10		6-16		8-24		11-32		16-46		
1-Way	2-8		4-14		8-22		12-34						
14" x 14" 1.36	0.880	CFM NC	270 <20		405 21		545 29		680 36		815 41		
		Throw	4-Way	1-4		3-9		5-15		8-23		10-29	
			3-Way	1-4 2-6		3-9 4-13		5-15 7-21		8-23 11-32		10-29 14-41	
2-Way	2-6		4-13		7-21		11-32		14-41		20-58		
1-Way	2-8		6-18		10-30		16-46						
16" x 16" 1.78	1.152	CFM NC	355 <20		530 22		710 30		885 37		1070 42		
		Throw	4-Way	1-5		3-9		5-15		8-24		11-32	
			3-Way	1-5 2-7		3-9 4-13		5-15 7-21		8-24 11-34		11-32 16-45	
2-Way	2-7		4-13		7-21		11-34		16-45		22-64		
1-Way	2-10		6-18		10-30		16-48						
18" x 18" 2.25	1.456	CFM NC	450 <20		670 23		900 31		1120 37		1345 43		
		Throw	4-Way	1-6		3-10		5-16		9-27		12-35	
			3-Way	1-6 2-8		3-10 4-14		5-16 7-23		9-27 13-38		12-35 17-49	
2-Way	2-8		1-14		7-23		13-38		17-49		24-70		
1-Way	2-11		6-20		10-32		18-54						
20" x 20" 2.78	1.800	CFM NC	560 <20		830 24		1110 32		1385 38		1665 44		
		Throw	4-Way	2-6		3-11		6-18		9-27		12-36	
			3-Way	2-6 3-8		3-11 4-16		6-18 8-25		9-27 13-38		12-36 17-51	
2-Way	3-8		4-16		8-25		13-38		17-51		24-72		
1-Way	4-12		6-22		12-36		18-54						

### Series 7900 Performance Notes:

All data are tested in accordance with ANSI/ASHRAE 70-1991

### Definition of Units:

CFM - Cubic Feet per Minute (air)

fpm - Velocity of air stream in Feet Per Minute

Pt - Total pressure (inches of water column)

Throw - Non-isothermal horizontal throw (supply air temperature 20°F colder than average room air temperature) values are for 150 fpm - 50 fpm velocities

NC - Noise criterion, sound pressure level. NC ratings are based on sound power level (Lw) RE: 10E-12 watts minus a 10 dB room attenuation in all octave bands





## Series 7900 - Specification

Supply - Perforated Modular Core - Extruded Aluminum - Square Neck - 1 to 4 Core/Series 7900

**Steel**

- 7900-1 - Surface Mounted
- 7900-6 - T-bar Lay-in
- 7900-8 - T-bar

Air Outlets shall be aluminum model 7900 manufactured by METALAIRE. Units shall consist of an aluminum 51% free area perforated face with 3/16" diameter perforated holes on 1/4" staggered centers. Border of outlet shall be constructed from an aluminum extrusion.

The perforated face shall be removable allowing access to adjustable modular core pattern controllers mounted onto the inside neck of the outlet. Steel modular cores deflectors are not acceptable. Face shall be secured in place with tension spring clips. Outlets shall be field adjustable allowing 1, 2 way opposite, 2 way corner, 3, and 4 way directional air patterns.

The units shall be the size and quantity as outline in the plans and specifications.

Units shall be designed to integrate into the specified ceiling system.

### Square Neck Options and Accessories

**Opposed Blade Damper**

METALAIRE model OBDA aluminum and OBD steel opposed blade type dampers shall be provided. Damper shall consist of gang operated blades that can be adjusted from full open to full closed. Damper shall be screw slot operated that can be accessed through the damper of the diffuser.

**Equalizing Grid**

METALAIRE model L9 aluminum square equalizing grid shall be provided. Equalizing grid shall consist aluminum blades mounting in an aluminum frame.

### Round Neck Optional Dampers and Accessories

**Square to Round Transitions**

Units to have square to round transitions allowing installation with round ductwork.

**Butterfly Damper**

METALAIRE model BDS aluminum round butterfly type dampers shall be provided. Damper shall consist of two butterfly style blades that can be adjusted from full open to full closed. Damper shall be adjusted with a screw driver slot that can be assessed through the face of the diffuser.

**Radial Shutter Damper**

METALAIRE model RSD steel round radial shutter damper shall be provided. Damper shall consist of gang operated radial blades that slide perpendicular to air flow direction. The damper shall be adjusted from full open to full closed. Damper shall be adjusted with a screw driver slot that can be assessed through the face of the diffuser.

**Opposed Blade Damper**

METALAIRE model D3 aluminum or SD3 steel round opposed blade type dampers shall be provided. Damper shall consist of gang operated blades that can be adjusted from full open to full closed. Damper shall be adjusted with a screw driver slot that can be assessed through the face of the diffuser.

**Equalizing Grid**

METALAIRE model G3 aluminum round equalizing grid shall be provided. Equalizing grid shall consist of 1/2" x 1/2" x 1/2" aluminum cubed core mounting in an aluminum frame.

### Performance Specification

The manufacturer shall provide published performance data. Data shall be tested in accordance to ANSI/ASHRAE Standard 70-1991.

### Paint Specification

Process shall be anodic electrodeposition using an anodic acrylic paint. Units shall undergo pre-treatment including a pressurized spray stage using an alkaine cleaner and a de-ionized water rinse.

Film Properties shall meet or exceed the following standards:

Property	Test Method	Performance
Film thickness		.8-1.0 mils
Film Cure		320 F @ 20 min
Gloss – 60 deg.	ASTM D523-89	70-80%
Pencil Hardness	ASTM D3363-92A	HB-H
Crosshatch Adhesion	ASTM D3359-95	4B-5B
Direct Impact	ASTM D2794-93	100 in.lbs. Min
Reverse Impact	ASTM D2794-93	60 in.lbs. Min.
Salt Spray	ASTM B117-95	48-96 Hours
Humidity	ASTM D1735-92	500 Hours
Water Soak	ASTM D870-92	250 Hours

Perforated Ceiling Diffusers



PCD

# PCD - Perforated Ceiling Diffusers

## Series 7900 - Model Specification Guide

### Supply - Perforated Face Modular Core Diffuser Steel Back Pan/Steel Face - Series 7900

Model	Available Neck	Module	Air Pattern	Available Finishes	Available Options	
7900-1 - Surface Mount	6" x 6" 8" x 8" 10" x 10" 12" x 12" 14" x 14" 16" x 16" 18" x 18" 20" x 20"	12" x 12" 24" x 12" 20" x 20" 24" x 24" 48" x 24"	S1-1- 1 Core S4-4- 4-Cores	Standard	Square Neck Accessories	
				01 - White	OBD	Opposed Blade Damper - Steel
				Optional	OBDA	Opposed Blade Damper - Aluminum
				03 - Black	L9	Equalizing Grid
				22 - Black Back Pan White Face	TR	Square to Round Transitions
				28 - Custom Color	TR-Deep	Square to Round Transitions - Deep
					Round Neck Accessories	
					G3	Equalizing Grid
					BDS	Butterfly Damper
					RSD	Radial Shutter Damper
					D3	Round Opposed Blade Damper - Aluminum
					SD3	Round Opposed Blade Damper - Steel

Model	Available Neck	Module	Air Pattern	Available Finishes	Available Options	
7900-6 - T-bar Lay-in 7900-8 - T-regular T-bar	6" x 6" 8" x 8" 10" x 10" 12" x 12" 14" x 14" 16" x 16" 18" x 18" 20" x 20"	12" x 12" 24" x 12" 20" x 20" 24" x 24" 48" x 24"	S1-1- 1 Core S4-4- 4-Cores	Standard	Square Neck Accessories	
				01 - White	OBD	Opposed Blade Damper - Steel
				Optional	OBDA	Opposed Blade Damper - Aluminum
				03 - Black	L9	Equalizing Grid
				22 - Black Back Pan White Face	TR	Square to Round Transitions
				28 - Custom Color	TR-Deep	Square to Round Transitions - Deep
					Round Neck Accessories	
					G3	Equalizing Grid
					BDS	Butterfly Damper
					RSD	Radial Shutter Damper
					D3	Round Opposed Blade Damper - Aluminum
					SD3	Round Opposed Blade Damper - Steel



# PCD - Perforated Ceiling Diffusers

8/2006

➔ Supply Diffusers ➔ Perforated Face Modular Core ➔ Square Neck ➔ Series 7950

## Product Details

- ✪ The 7950 is a perforated modular core supply diffuser with a steel backpan. Modular cores can be field adjusted for 1, 2-way opposite, 2-way corner, 3, or 4 way air discharge patterns
- ✪ The perforated face is secured with spring clips making removal and access to the modular core pattern controllers easy
- ✪ Border 6, T-bar Lay-in can be used in surface mounting applications by adding optional T-bar Plaster Frame (TBPF)
- ✪ Matching returns available: 7950R
- ✪ The 7950 is an excellent choice for VAV applications

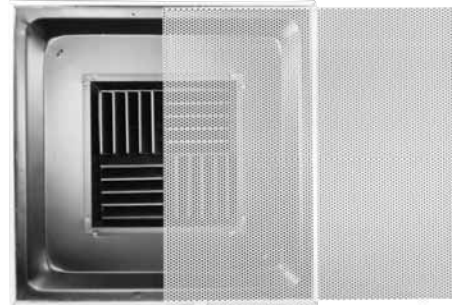

### Model 7950-6 Shown

Standard Finish: 22 BBP White Perforated Face - Black Backpan and Core

Dimensions are in inches

#### Supply - Square Neck - Neck Mounted - Adjustable - Surface Mount

Model 7950-1 - Steel backpan & face  
 Model 7950-1 DF - Steel backpan & face - drop face  
 Model 7950-1 AF - Steel backpan & aluminum face

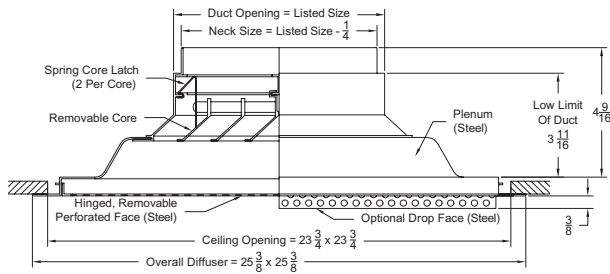

#### Supply - Square Neck - Neck Mounted - Adjustable - T-bar Lay-in

Model 7950-6 - Steel backpan & face  
 Model 7950-6 AF - Steel backpan & aluminum face - drop face

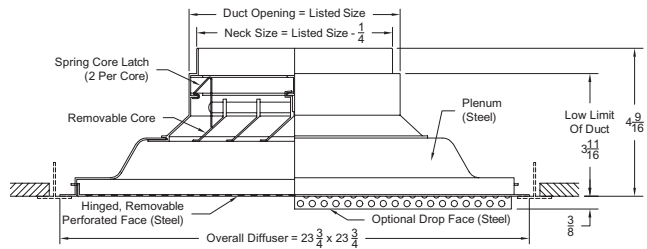

#### Supply - Square Neck - Neck Mounted - Adjustable - Tegular T-bar

Model 7950-8 - Steel backpan & face  
 Model 7950-8 AF - Steel backpan & aluminum face

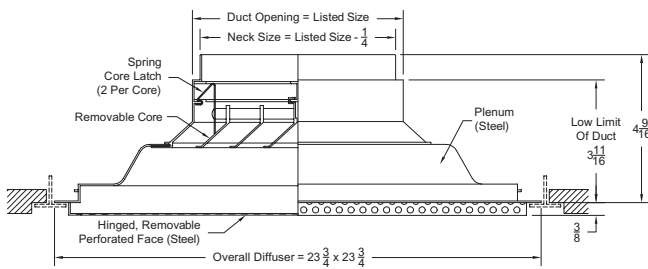

#### Supply - Square Neck - Neck Mounted - Adjustable - Donn Finline

Model 7950-9 - Steel backpan & face  
 Model 7950-9 AF - Steel backpan & aluminum face

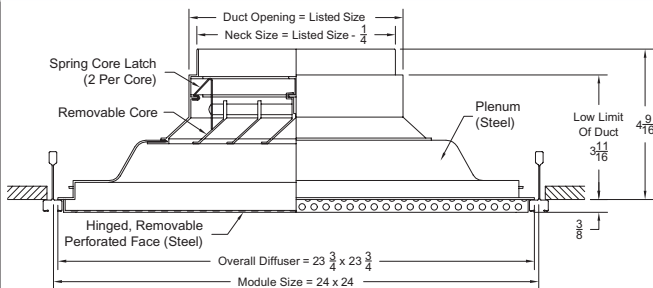

# PCD - Perforated Ceiling Diffusers

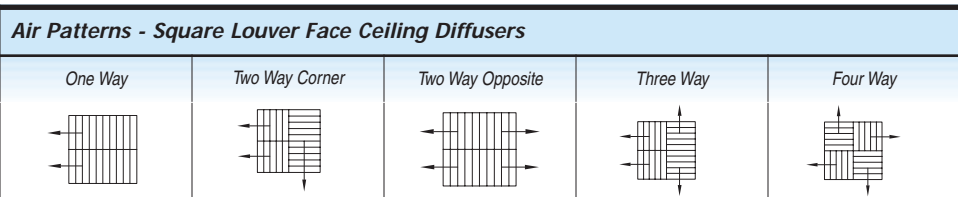

1. Available Finishes	2. Available Accessories	3. Construction Details
<b>Standard Finish:</b> 01 White (for 7950-1) 22 (BBP) White perforated face with black backpan and cores <b>Optional Finish</b> 03 Black 28 Custom color	OBD - Opposed blade damper - Steel ..... 334 OBDA - Opposed blade damper - Aluminum ..... 334 L9 - Equalizing grid ..... 334 TR DEEP - Square to round transition - deep ..... 338	<ul style="list-style-type: none"> <li>All modules have 4 cores for possible 1, 2, 3 or 4 way air patterns</li> <li>Series 7950 have 3/16" diameter holes on 1/4" staggered centers</li> </ul>

## Series 7950 - Performance

All models for Series 7950 (-1, -6, -8, -9), 7950-1 DF, 7950 AF (-1, -6, -8, -9)

Listed Size (ft.) & Neck Area Sq. Ft.	Neck Velocity fpm Outlet Velocity fpm Side Designation	200 305		300 460		400 615		500 770		600 925	
		A	B	A	B	A	B	A	B	A	B
6" x 6"	CFM	50		75		100		125		150	
	NC	-		-		-		20		24	
	Pt. Total Pressure (in. w.c)	0.006		0.016		0.032		0.049		0.065	
Throw	4-Way	1-3		1-4		2-6		3-9		4-12	
	3-Way	1-3 2-4		1-4 2-6		2-6 3-8		3-9 4-13		4-12 6-17	
	2-Way	2-4		2-6		3-8		4-13		6-17	
	1-Way	2-6		2-8		4-12		6-18		12-24	
8" x 8"	CFM	90		135		175		225		265	
	NC	-		-		18		24		30	
	Pt. Total Pressure (in. w.c)	0.012		0.025		0.042		0.069		0.080	
Throw	4-Way	1-3		2-6		3-9		4-12		5-15	
	3-Way	1-3 2-4		2-6 3-8		3-9 4-13		4-12 6-17		5-15 7-21	
	2-Way	2-4		3-8		4-13		6-17		7-21	
	1-Way	2-6		4-12		6-18		8-24		10-30	
10" x 10"	CFM	140		205		275		345		415	
	NC	-		-		22		25		31	
	Pt. Total Pressure (in. w.c)	0.012		0.027		0.019		0.076		0.110	
Throw	4-Way	1-3		2-7		3-9		5-15		7-20	
	3-Way	1-3 2-4		2-7 3-10		3-9 4-13		5-15 7-21		7-20 10-28	
	2-Way	2-4		3-10		4-13		7-21		10-28	
	1-Way	2-6		4-14		6-18		10-30		14-40	
12" x 12"	CFM	200		300		400		500		600	
	NC	-		-		23		26		32	
	Pt. Total Pressure (in. w.c)	0.014		0.030		0.054		0.085		0.122	
Throw	4-Way	1-4		2-7		4-11		6-17		8-23	
	3-Way	1-4 2-6		2-7 3-10		4-11 6-16		6-17 8-24		8-23 11-32	
	2-Way	2-6		3-10		6-16		8-24		11-32	
	1-Way	2-8		4-14		8-22		12-34		16-46	
14" x 14"	CFM	275		410		545		680		815	
	NC	-		-		-		-		33	
	Pt. Total Pressure (in. w.c)	0.014		0.032		0.057		0.009		0.129	
Throw	4-Way	1-4		3-9		5-15		8-24		11-32	
	3-Way	1-4 2-6		3-9 4-13		5-15 7-21		8-23 11-32		10-29 14-41	
	2-Way	2-6		4-13		7-21		11-32		14-41	
	1-Way	2-8		6-18		10-30		16-46		20-58	
16" x 16"	CFM	355		530		710		890		1065	
	NC	-		-		25		33		38	
	Pt. Total Pressure (in. w.c)	0.016		0.034		0.061		0.095		0.137	
Throw	4-Way	1-5		3-9		5-15		8-21		11-32	
	3-Way	1-5 2-7		3-9 4-13		5-15 7-21		8-24 11-34		11-32 16-45	
	2-Way	2-7		4-13		7-21		11-34		16-45	
	1-Way	2-10		6-18		10-30		16-48		22-64	
18" x 18"	CFM	450		675		900		1125		1350	
	NC	-		-		26		35		39	
	Pt. Total Pressure (in. w.c)	0.016		0.036		0.065		0.102		0.149	
Throw	4-Way	1-6		3-10		5-16		9-27		12-35	
	3-Way	1-6 2-8		3-10 4-14		5-16 7-23		9-27 13-38		12-35 17-49	
	2-Way	2-8		1-14		7-23		13-38		17-49	
	1-Way	2-11		6-20		10-32		18-54		24-70	
20" x 20"	CFM	555		835		1110		1385		1665	
	NC	-		-		27		37		40	
	Pt. Total Pressure (in. w.c)	0.016		0.038		0.068		0.106		0.158	
Throw	4-Way	1-5		3-9		5-15		8-24		11-32	
	3-Way	1-5 2-7		3-9 4-13		5-15 7-21		8-24 11-34		11-32 16-45	
	2-Way	2-7		4-13		7-21		11-34		16-45	
	1-Way	2-10		6-18		10-30		16-48		22-64	

**Series 7950 Performance Notes:**  
 All data are tested in accordance with ANSI/ASHRAE 70-1991

- Definition of Units:**
- CFM - Cubic feet per minute (air)
  - fpm - Velocity of air stream in feet per minute
  - Pt - Total pressure (inches of water column)
  - Throw - Non-isothermal horizontal throw (supply air temperature 20°F colder than average room air temperature) values are for 150 fpm - 50 fpm velocities
  - NC - Noise criterion, sound pressure level. NC ratings are based on sound power level (Lw) RE: 10E-12 watts minus a 10 dB room attenuation in all octave bands

## Series 7950 - Specification

### Supply Diffusers - Perforated Modular Core - Square Neck - 4 Core/Series 7950

<b>Steel</b>	<b>Aluminum Face - Steel Backpan</b>
7950-1 - Surface Mounted	7950-1 AF - Surface Mounted
7950-1 DF - Surface Mounted-Dropped Face	7950-6 AF - T-bar Lay-in
7950-6 - T-bar Lay-in	7950-8 AF - Tegalur T-bar
7950-8 - Tegalur T-bar	7950-9 AF - Donn Finline
7950-9 - Donn Finline	

Air Outlets shall be steel model 7950 or aluminum face, steel backpan model 7950-AF manufactured by METALAIRES.

Units shall consist of aluminum 51% free area perforated face with 3/16" diameter perforated holes on 1/4" staggered centers. The perforated face shall be hinged allowing access to four adjustable aluminum modular core pattern controllers mounted into the neck of the outlet. Steel modular cores deflectors are not acceptable. Face shall be secured in place with tension spring clips. Outlets shall be field adjustable allowing 1, 2-way opposite, 2-way corner, 3, and 4-way directional air patterns.

The units shall be the size and quantity as outline in the plans and specifications.

Units shall be designed to integrate into the specified ceiling system.

### Square Neck Options and Accessories

#### Opposed Blade Damper

METALAIRES model OBDA aluminum or OBD steel round opposed blade type dampers shall be provided. Damper shall consist of gang operated blades that can be adjusted from full open to full closed. Damper shall be adjusted with a handle accessible by opening the face of the diffuser.

#### Equalizing Grid

METALAIRES model L9 aluminum square equalizing grid shall be provided. Equalizing grid shall consist aluminum blades mounting in an aluminum frame.

### Round Neck Optional Dampers and Accessories:

#### Square to Round Transitions

Units to have square to round transitions allowing installation with round ductwork.

#### Butterfly Damper

METALAIRES model BDS aluminum round butterfly type dampers shall be provided. Damper shall consist of two butterfly style blades that can be adjusted from full open to full closed. Damper shall be adjusted with a screw driver slot that can be assessed through the face of the diffuser.

#### Radial Shutter Damper

METALAIRES model RSD steel round radial shutter damper shall be provided. Damper shall consist of gang operated radial blades that slide perpendicular to air flow direction. The damper shall be adjusted from full open to full closed. Damper shall be adjusted with a screw driver slot that can be assessed through the face of the diffuser.

#### Opposed Blade Damper

METALAIRES model D3 aluminum or SD3 steel round opposed blade type dampers shall be provided. Damper shall consist of gang operated blades that can be adjusted from full open to full closed. Damper shall be adjusted with a screw driver slot that can be assessed through the face of the diffuser.

#### Equalizing Grid

METALAIRES model G3 aluminum round equalizing grid shall be provided. Equalizing grid shall consist of 1/2" x 1/2" x 1/2" aluminum cubed core mounting in an aluminum frame.

### Performance Specification

The manufacturer shall provide published performance data. Data shall be tested in accordance to ANSI/ASHRAE Standard 70-1991.

### Paint Specification

Process shall be anodic electrodeposition using an anodic acrylic paint. Units shall undergo pre-treatment including a pressurized spray stage using an alkaine cleaner and a de-ionized water rinse.

Film Properties shall meet or exceed the following standards:

Property	Test Method	Performance
Film thickness		.8-1.0 mils
Film Cure		320 F @ 20 min
Gloss – 60 deg.	ASTM D523-89	70-80%
Pencil Hardness	ASTM D3363-92A	HB-H
Crosshatch Adhesion	ASTM D3359-95	4B-5B
Direct Impact	ASTM D2794-93	100 in.lbs. Min
Reverse Impact	ASTM D2794-93	60 in.lbs. Min.
Salt Spray	ASTM B117-95	48-96 Hours
Humidity	ASTM D1735-92	500 Hours
Water Soak	ASTM D870-92	250 Hours



# PCD - Perforated Ceiling Diffusers

## Series 7950 - Model Specification Guide

Supply - Perforated Face Modular Core Diffuser - 4 Cores  
Steel Back Pan/Steel Face - Series 7950

Model	Available Neck	Module	Available Finishes	Available Options	
7950-1 - Surface Mount 7950-1 DF - Surface Mount with Drop Face 7950-1 AF - Surface Mount with Aluminum Face	6" x 6" 8" x 8" 10" x 10" 12" x 12" 14" x 14" 16" x 16" 18" x 18" 20" x 20"	24" x 24"	Standard	Square Neck Accessories	
			01 -White	OBD	Opposed Blade Damper - Steel
			Optional	OBDA	Opposed Blade Damper - Aluminum
			03 - Black	L9	Equalizing Grid
			22 - Black Back Pan White Face	TR	Square to Round Transitions
			28 - Custom Color	TR-Deep	Square to Round Transitions - Deep
			Round Neck Accessories		
			G3	Equalizing Grid	
			BDS	Butterfly Damper	
			RSD	Radial Shutter Damper	
			D3	Round Opposed Blade Damper - Aluminum	
SD3	Round Opposed Blade Damper - Steel				

Model	Available Neck	Module	Available Finishes	Available Options	
7950-6 - T-bar Lay-in 7950-6 AF - T-bar Lay-in - Aluminum Face 7950-8 - Tegular T-bar 7950-8 AF - Tegular T-bar - Aluminum Face 7950-9 - Donn Finline	6" x 6" 8" x 8" 10" x 10" 12" x 12" 14" x 14" 16" x 16"	24" x 24"	Standard	Square Neck Accessories	
			01 -White	OBD	Opposed Blade Damper - Steel
			Optional	OBDA	Opposed Blade Damper - Aluminum
			03 - Black	L9	Equalizing Grid
			22 - Black Back Pan White Face	TR	Square to Round Transitions
			28 - Custom Color	TR-Deep	Square to Round Transitions - Deep
			Round Neck Accessories		
			G3	Equalizing Grid	
			BDS	Butterfly Damper	
			RSD	Radial Shutter Damper	
			D3	Round Opposed Blade Damper - Aluminum	
SD3	Round Opposed Blade Damper - Steel				



# PCD - Perforated Ceiling Diffusers

8/2006

- ➔ Perforated Filter Back ➔ Square Neck ➔ Series 7550R F ➔ Steel
- ➔ Series 7650R F ➔ Steel

## Product Details

- ★ Unit can be used in surface mounting applications by adding optional T-bar plaster frame (TBPF)
- ★ T-bar Lay-in border type 6 is designed to be installed in standard 15/16" tee
- ★ The hinged, perforated face, allows access to the filter (by others)
- ★ 7550R-F matches series 7500 perforated diffuser. 7650R-F matches series 7600 supply diffusers

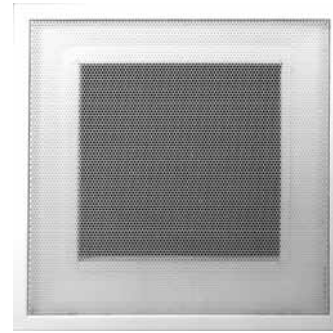

**Model 7550R F Shown**  
Standard Finish: 01 White

Dimensions are in inches

**Return - Perforated Filter Diffuser**  
**Surface Mount**  
Model 7550R-1 F  
Model 7650R-1 F

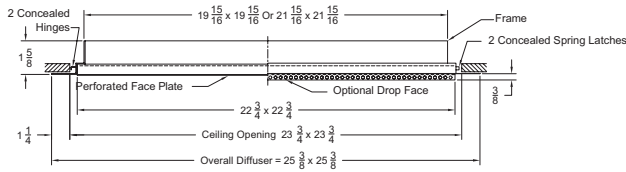

**Return - Perforated Filter Diffuser**  
**T-bar Lay-in**  
Model 7550R-6 F  
Model 7650R-6 F

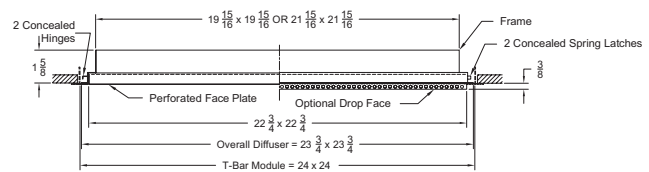

**Return - Perforated Filter Diffuser**  
**Tegular T-bar**  
Model 7550R-8 F  
Model 7650R-8 F

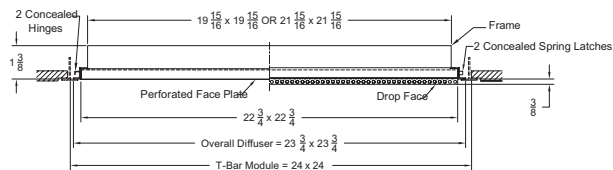

1. Available Finishes	2. Available Accessories	3. Construction Details
<p><b>Standard Finish:</b> 01 White</p> <p><b>Optional Finish</b> 02 Aluminum 03 Black 28 Custom color</p>	<p><b>Shipped Unattached</b></p> <p><b>OBD</b> - Opposed Blade Damper (square neck) - Steel . . . . .334</p> <p><b>OBDA</b> - Opposed Blade Damper (square neck) - Aluminum . .334</p>	<ul style="list-style-type: none"> <li>• Seismic tabs standard on all units</li> <li>• Series 7550R-F and 7650R-F have 3/16" diameter holes on 1/4" center</li> </ul>

Perforated Ceiling Diffusers



PCD

# PCD - Perforated Ceiling Diffusers

## Series 7550R F/7650 F - Performance

Models 7550R F (-1, -6, -8), 7650R F (-1, -6, -8)

Nominal Neck Size	fpm Inlet Velocity	300	400	500	600	700	800	900	1000
	Ps (in. w.c.)	-.008	-.015	-.02	-.03	-.05	-.06	-.08	-.09
6" x 6"	CFM	75	100	120	150	175	200	225	250
8" x 8"	CFM	130	175	220	265	310	350	400	445
10" x 10"	CFM	210	275	345	415	485	555	625	695
12" x 12"	CFM	300	400	500	600	700	800	900	1000
14" x 14"	CFM	410	545	680	815	950	1090	1225	1360
16" x 16"	CFM	530	710	885	1060	1240	1415	1600	1770
22" x 22"	CFM	1010	1345	1680	2015	2350	2690	3025	3360

## Series 7550R F/7650R F - Specification

Exhaust/Return - Filter Grilles - Perforated Face - Series 7500/7600

### Series 7550

7550-1 F - Surface Mounted

7550-6 F - T-bar Lay-in

7550-8 F - Tegular T-bar

### Series 7650

7650-1 F - Surface Mounted

7650-6 F - T-bar Lay-in

7650-8 F - Tegular T-bar

Air Inlets shall be steel model 7550 F or 7650 F perforated face filter return diffusers manufactured by METALAIRE. Units shall consist of aluminum 51% free area perforated face with 3/16" diameter perforated holes on 1/4" staggered centers. Units shall include a hinged face and integral frame designed to accept a 1" thick filter. Face shall be secured in place with tension spring clips.

The units shall be the size and quantity as outline in the plans and specifications.

Units shall be designed to integrate into the specified ceiling system.

### Performance Specification

The manufacturer shall provide published performance data. Data shall be tested in accordance to ANSI/ASHRAE Standard 70-1991.

### Paint Specification

Process shall be anodic electrodeposition using an anodic acrylic paint. Units shall undergo pre-treatment including a pressurized spray stage using an alkaline cleaner and a de-ionized water rinse.

Film Properties shall meet or exceed the following standards:

Property	Test Method	Performance
Film thickness		.8-1.0 mils
Film Cure		320 F @ 20 min
Gloss - 60 deg.	ASTM D523-89	70-80%
Pencil Hardness	ASTM D3363-92A	HB-H
Crosshatch Adhesion	ASTM D3359-95	4B-5B
Direct Impact	ASTM D2794-93	100 in.lbs. Min
Reverse Impact	ASTM D2794-93	60 in.lbs. Min.
Salt Spray	ASTM B117-95	48-96 Hours
Humidity	ASTM D1735-92	500 Hours
Water Soak	ASTM D870-92	250 Hours





# PCD - Perforated Ceiling Diffusers

8/2006

## Series 7550R F/7650R F - Model Specification Guide

Supply - Perforated Face Modular Core Diffuser - 4 Cores  
Steel Back Pan/Steel Face - Series 7550RF, 7650RF

Model	Available Neck	Module	Available Finishes	Available Options
7550R-1 F - Surface Mount 7650R-1F - Surface Mount	20" x 20" 22" x 22"	24" x 24"	Standard	Square Neck Accessories
			01 - White	OBD   Opposed Blade Damper - Steel
			Optional	OBDA   Opposed Blade Damper - Aluminum
			03 - Black 28 - Custom Color	

Model	Available Neck	Module	Available Finishes	Available Options
7550R-6 F - T-bar Lay-in 7650R-6 F - T-bar Lay-in 7550R-8 F - Tegular T-bar 7650R-8 F - Tegular T-bar	20" x 20" 22" x 22"	24" x 24"	Standard	Square Neck Accessories
			01 - White	OBD   Opposed Blade Damper - Steel
			Optional	OBDA   Opposed Blade Damper - Aluminum
			03 - Black 28 - Custom Color	

Perforated Ceiling Diffusers



PCD

LINEAR  
SLOT  
DIFFUSERS

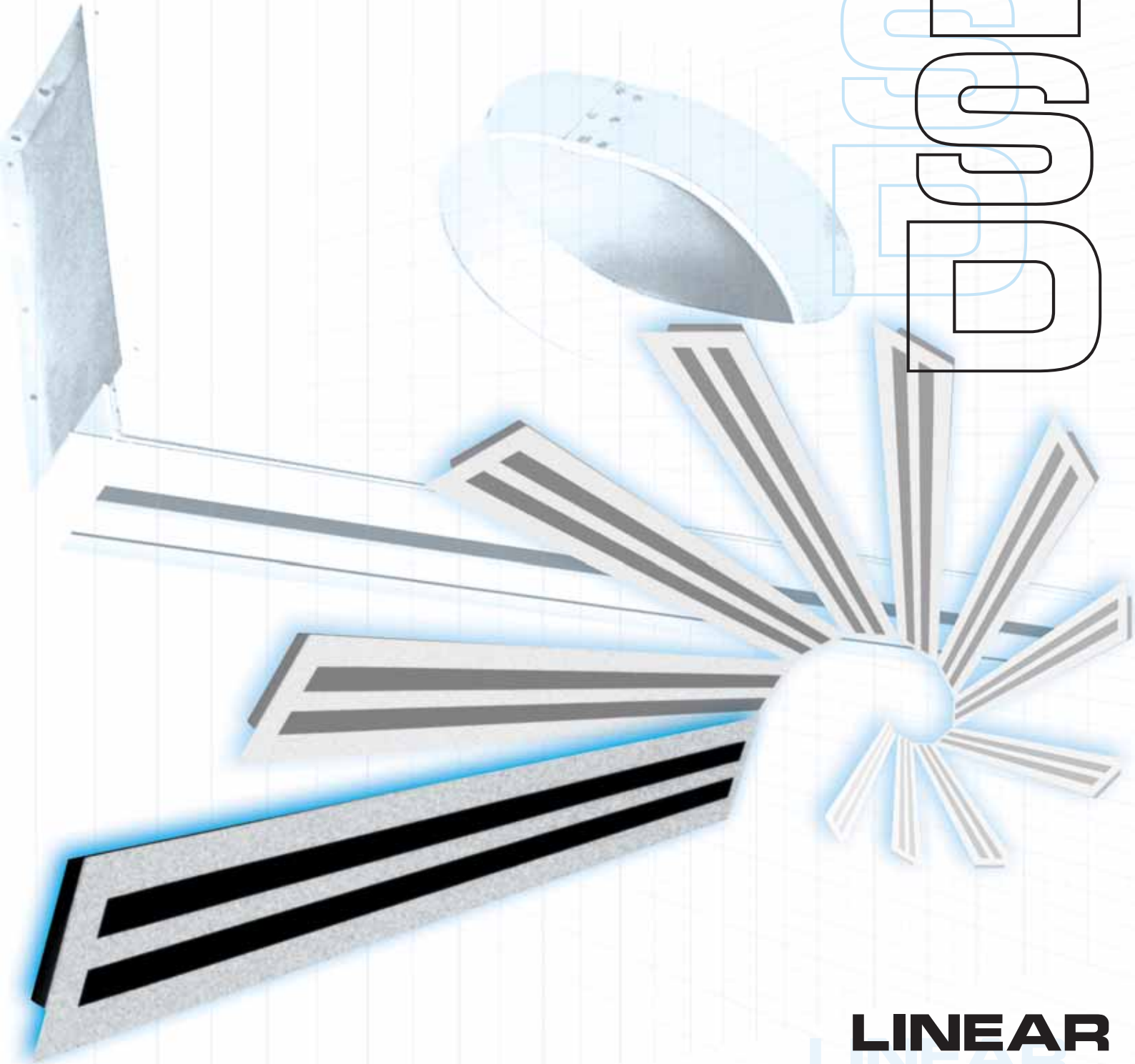

**LINEAR  
SLOT DIFFUSERS**



**Model 6600**

Pg. 166

## Supply/Return Linear Slot Diffuser w/ Integral Volume/Directional Pattern Controllers - Aluminum Series 6600/6600R

- ✳ Available in 1 to 8 slots with 1/2", 3/4", or 1" slot width
- ✳ Excellent choice for continuous linear slot applications. Units are available in a single section up to 8'. This feature gives a clean appearance and makes installation easier with fewer joints to line up
- ✳ Pattern controllers on supply units are aluminum and are adjustable from the face of the diffuser and can be set to adjust volume or throw direction from vertical to horizontal
- ✳ Available for T-bar Lay-in, Surface mount, Narrow Tee, Dropped Face, Concealed Spline, or Concealed Spline/Plaster Frame
- ✳ Optional BP factory supplied boot plenums are available
- ✳ The series 6600 is an excellent selection for variable volume systems supplying a tight horizontal pattern from maximum to minimum throws
- ✳ The series 6600R is designed for return applications. The unit is supplied without pattern controllers to reduce pressure and noise
- ✳ Series 6600 is Patent Pending

	Supply				
	T-bar Lay-in	Surface Mount	Concealed Spline	Drop Face	Narrow Tee
Screw Mounted		6600-11-1 1 1/8" Border			
Concealed Mounting Hardware	6600-12-6 1 1/8" Border	6600-12-1 1 1/8" Border	6600-42-7 25/32" Border		
No Mounting Hardware	6600-10-6 1 1/8" Border		6600-40-7 25/32" Border	6600-40-8 25/32" Border	6600-40-9 25/32" Border
	6600-20-6 3/4" Border				
	6600-30-6 1/2" Border				

Concealed Spline/Plaster Mounting Frame	Concealed Wall Mounted Spline/Plaster Mounting Frame
6600-22-73 3/4" Border	6600-22-74 3/4" Border

	Return				
	T-bar Lay-in	Surface Mount	Concealed Spline	Drop Face	Narrow Tee
Screw Mounted		6600R-11-1 1 1/8" Border			
Concealed Mounting Hardware	6600R-12-6 1 1/8" Border	6600R-12-1 1 1/8" Border	6600R-42-7 25/32" Border		
No Mounting Hardware	6600R-10-6 1 1/8" Border		6600R-40-7 25/32" Border	6600R-40-8 25/32" Border	6600R-40-9 25/32" Border
	6600R-20-6 3/4" Border				
	6600R-30-6 1/2" Border				

Concealed Spline/Plaster Mounting Frame	Concealed Wall Mounted Spline/Plaster Mounting Frame
6600R-22-73 3/4" Border	6600R-22-74 3/4" Border



**Model 6610SP**

Pg. 184

## Supply/Return Linear Slot Diffuser for Spiral Pipe - Aluminum - Series 6600SP/6600SPR

- ✳ The series 6600SP is designed to integrate into exposed spiral duct systems
- ✳ Series 6600SP pattern controllers are fully adjustable and can be set from horizontal to vertical discharge
- ✳ The series 6600SP operates effectively from minimum to maximum flow making this diffuser an excellent selection for variable volume systems
- ✳ Series 6600SPR is designed for return applications. The unit is supplied without pattern controllers to reduce pressure and noise

Supply	Return
6610SP-11-1 Screw Mounted - 1 1/8" Border	6610SPR-11-1 Screw Mounted - 1 1/8" Border
6610SP-12-1 Concealed Mounting Hardware - 1 1/8" Border	6610SPR-12-1 Concealed Mounting Hardware - 1 1/8" Border



**Model BP**

Pg. 190

## Boot Plenums - Insulated/Non-Insulated for 6600 - Series BP

- ★ The series BP (non-insulated) and BPI (insulated) boot plenums are designed to connect the Series 6600 linear slot diffusers to the ducted supply or return system
- ★ Units provide an even distribution of air into the series 6600 diffuser to maximize induction and occupant comfort
- ★ The series BPI boot plenum is fully insulated — including the end caps
- ★ Units can be used for both ducted and plenum returns
- ★ Factory tested and manufactured BP/BPI plenums are built to fit securely into the series 6600 of diffusers reducing installation cost and minimizing leakage
- ★ Available with an optional quadrant locking damper
- ★ Series BP & BPI are shipped separate from series 6600 linear slot diffusers and require field attachment

	Non Insulated				
	T-bar Lay-in	Surface Mount	Concealed Spline	Drop Face	Narrow Tee
Screw Mounted		BP-11-1 1 1/8" Border			
Concealed Mounting Hardware	BP-12-6 1 1/8" Border	BP-12-1 1 1/8" Border	BP-42-7 25/32" Border		
No Mounting Hardware	BP-10-6 1 1/8" Border		BP-40-7 25/32" Border	BP-40-8 25/32" Border	BP-40-9 25/32" Border
	BP-20-6 3/4" Border				
	BP-30-6 1/2" Border				

Concealed Spline/Plaster Mounting Frame	Concealed Wall Mounted Spline/Plaster Mounting Frame
BP-22-73 3/4" Border	BP-22-74 3/4" Border

	Insulated				
	T-bar Lay-in	Surface Mount	Concealed Spline	Drop Face	Narrow Tee
Screw Mounted		BPI-11-1 1 1/8" Border			
Concealed Mounting Hardware	BPI-12-6 1 1/8" Border	BPI-12-1 1 1/8" Border	BPI-42-7 25/32" Border		
No Mounting Hardware	BPI-10-6 1 1/8" Border		BPI-40-7 25/32" Border	BPI-40-8 25/32" Border	BPI-40-9 25/32" Border
	BPI-20-6 3/4" Border				
	BPI-30-6 1/2" Border				

Concealed Spline/Plaster Mounting Frame	Concealed Wall Mounted Spline/Plaster Mounting Frame
BP-22-73 3/4" Border	BPI-22-74 3/4" Border



**Model L-5000**

Pg. 200

## Linear Louver Diffusers - Series L-5000

- ★ The series L-5000 is a fixed pattern, high induction architectural linear slot diffuser. This diffuser is constructed from heavy aluminum extrusions and is available with either 1-way or 2-way opposite air discharge patterns
- ★ The series L-5000 generates a tight, high induction discharge of air maximizing room air mixing and occupant comfort. With the optional IV induction vanes, mixing and performance is further increased reducing temperature gradients and increasing room air circulation
- ★ Also available is an optional plenum that allows the 2-way opposite unit to become a supply/return diffuser. The optional L-5000 BP-SR has a dividing section built into the plenum making an effective choice for perimeter supply/return applications
- ★ T-bar Lay-in units available in 18", 24", 30" or 42" and in surface mounting applications up to 48"
- ★ 1-way units available in 3", 6", 9", 12" and 15" widths
- ★ 2-way opposite units available in 6" and 12" widths
- ★ The louvered face is secured with spring clips making removal easy for installation
- ★ The series L-5000 is an excellent choice for VAV applications

Surface Mount	L-5000-1
T-bar Lay-in	L-5000-6

## ➔ Linear Slot ➔ Series 6600 ➔ Aluminum

### Product Details

- ✦ Available in 1 to 8 slots with 1/2", 3/4", or 1" slot width
- ✦ Excellent choice for continuous linear slot applications. Units are available in a single section up to 8'. This feature gives a clean appearance and makes installation easier with fewer joints to line up
- ✦ Pattern controllers on supply units are aluminum and are adjustable from the face of the diffuser and can be set to adjust volume or throw direction from vertical to horizontal
- ✦ Available for T-bar Lay-in, surface mount, narrow tee, dropped face, concealed spline, or concealed spline/plaster frame
- ✦ Optional BP factory supplied boot plenums are available
- ✦ The 6600 series is an excellent selection for variable volume systems supplying a tight horizontal pattern from maximum to minimum throws
- ✦ The 6600R is designed for return applications. The unit is supplied without pattern controllers to reduce pressure and noise

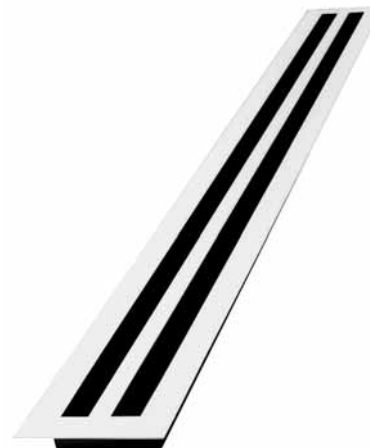

### **Model 6600 Shown**

Finish: 20 White Border  
with Black Pattern Controller

### About The 6600 (Patent Pending)

The 6600 is an excellent choice for continuous linear applications such as perimeter office space where the diffuser can direct air along the perimeter wall or glass and towards the occupied area to maximize comfort. Other applications for the 6600 linear slot diffuser include large public areas that demand superior comfort such as airport terminals, convention centers, or shopping malls. The flexibility of the 6600 allows the diffuser to be installed in a variety of applications to maximize occupant comfort.

The Series 6600 pattern controllers can be adjusted from the face to obtain vertical to horizontal throw. Pattern can be field set for "left" or "right" horizontal throw direction. Multiple slot units can be field set for one or two-way opposite horizontal throw.

In the horizontal setting, the diffuser produces a tight air pattern from maximum to minimum flow, making the 6600 an excellent choice for variable volume systems.

**Model 6600 - Supply**



**Model 6600 - Return**



6600 Pattern Controllers can be field-adjusted to vary discharge volume while maintaining a tight horizontal pattern



# LSD - Linear Slot Diffusers

Dimensions are in inches

**Series 6600-10-6**  
T-bar Lay-in  $\Rightarrow$  1 1/8" Border

**Series 6600-12-6**  
T-bar Lay-in  $\Rightarrow$  1 1/8" Border  $\Rightarrow$  Concealed Mount

Supply - 1 1/8" Border - T-bar Lay-in

Model 6650-10-6 - 1/2" Slot Width  
Model 6675-10-6 - 3/4" Slot Width  
Model 6610-10-6 - 1" Slot Width

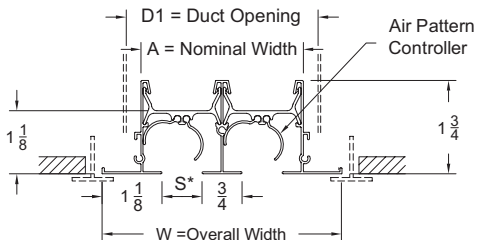

Supply - 1 1/8" Border - T-bar Lay-in

Model 6650-12-6 - 1/2" Slot Width  
Model 6675-12-6 - 3/4" Slot Width  
Model 6610-12-6 - 1" Slot Width

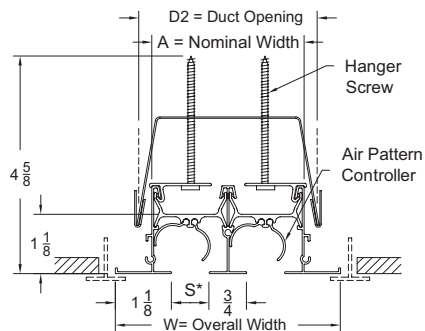

**End Border**  
Models 6600-10-6 & 6600-12-6

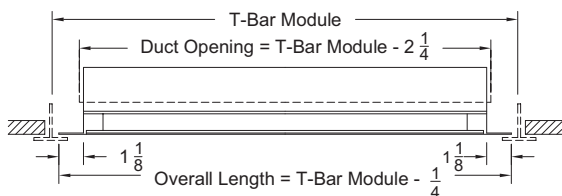
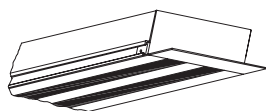

**End Cap**  
Models 6600-10-6 & 6600-12-6

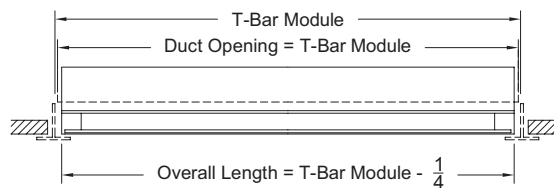
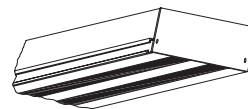

## Air Deflection Patterns

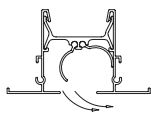

Right Horizontal

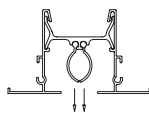

Vertical Projection

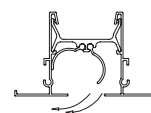

Left Horizontal

Model 6650 (6650-10-6 & 6650-12-6)								
S = 1/2" Slot	Number of Air Slots							
	1	2	3	4	5	6	7	8
A	1 1/4	2 1/2	3 3/4	5	6 1/4	7 1/2	8 3/4	10
D1	1 5/8	2 7/8	4 1/8	5 3/8	6 5/8	7 7/8	9 1/8	10 3/8
D2	1 7/8	3 1/8	4 3/8	5 5/8	6 7/8	8 1/8	9 3/8	10 5/8
W	2 3/4	4	5 1/4	6 1/2	7 3/4	9	10 1/4	11 1/2

Model 6610 (6610-10-6 & 6610-12-6)								
S = 1" Slot	Number of Air Slots							
	1	2	3	4	5	6	7	8
A	1 3/4	3 1/2	5 1/4	7	8 3/4	10 1/2	12 1/4	14
D1	2 1/8	3 7/8	5 5/8	7 3/8	9 1/8	10 7/8	12 5/8	14 3/8
D2	2 3/8	4 1/8	5 7/8	7 5/8	9 3/8	11 1/8	12 7/8	14 5/8
W	3 1/4	5	6 3/4	8 1/2	10 1/4	12	13 3/4	15 1/2

Model 6675 (6675-10-6 & 6675-12-6)								
S = 3/4" Slot	Number of Air Slots							
	1	2	3	4	5	6	7	8
A	1 1/2	3	4 1/2	6	7 1/2	9	10 1/2	12
D1	1 7/8	3 3/8	4 7/8	6 3/8	7 7/8	9 3/8	10 7/8	12 3/8
D2	2 1/8	3 5/8	5 1/8	6 5/8	8 1/8	9 5/8	11 1/8	12 5/8
W	3	4 1/2	6	7 1/2	9	10 1/2	12	13 1/2

6600R return has same dimensions as 6600 supply but provided without pattern controllers to reduce sound and pressure drop

For more product information visit us at [www.metalair.com](http://www.metalair.com)

# LSD - Linear Slot Diffusers

8/2006

**Series 6600-20-6**  
**T-bar Lay-in  $\Rightarrow$  3/4" Border**

**Supply - 3/4" Border - T-bar Lay-in**

Model 6650-20-6 - 1/2" Slot Width

Model 6675-20-6 - 3/4" Slot Width

Model 6610-20-6 - 1" Slot Width

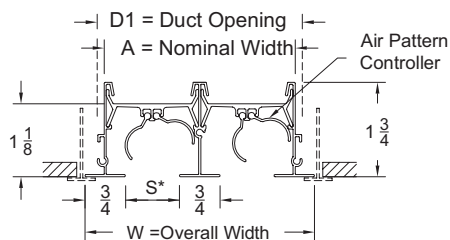

Linear Slot Diffusers

LSD

**End Border**  
**Model 6600-20-6**

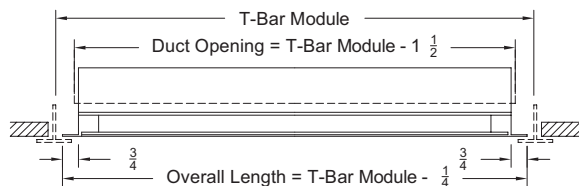
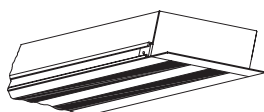

**End Cap**  
**Model 6600-20-6**

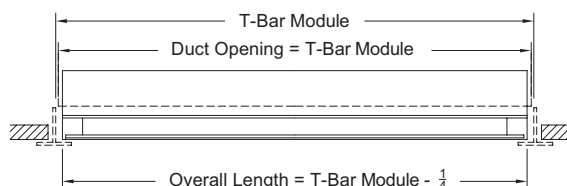
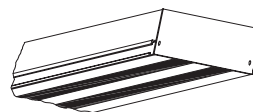

## Air Deflection Patterns

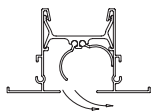

Right Horizontal

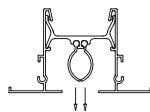

Vertical Projection

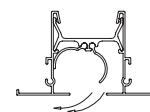

Left Horizontal

Model 6650								
S = 1/2" Slot	Number of Air Slots							
	1	2	3	4	5	6	7	8
A	1 1/4	2 1/2	3 3/4	5	6 5/16	7 1/2	8 3/4	10
D1	1 5/8	2 7/8	4 1/8	5 3/8	6 5/8	7 7/8	9 1/8	10 3/8
W	2	3 1/4	4 1/2	5 3/4	7	8 1/4	9 1/2	10 3/4

Model 6610								
S = 1" Slot	Number of Air Slots							
	1	2	3	4	5	6	7	8
A	1 3/4	3 1/2	5 1/4	7	8 3/4	10 1/2	12 1/4	14
D1	2 1/8	3 7/8	5 5/8	7 3/8	9 1/8	10 7/8	12 5/8	14 3/8
W	2 1/2	4 1/4	6	7 3/4	9 1/2	11 1/4	13	14 3/4

Model 6675								
S = 3/4" Slot	Number of Air Slots							
	1	2	3	4	5	6	7	8
A	1 1/2	3	4 1/2	6	7 1/2	9	10 1/2	12
D1	1 7/8	3 3/8	4 7/8	6 3/8	7 7/8	9 3/8	10 7/8	12 3/8
W	2 1/4	3 3/4	5 1/4	6 3/4	8 1/4	9 3/4	11 1/4	12 3/4

6600R return has same dimensions as 6600 supply but provided without pattern controllers to reduce sound and pressure drop

# LSD - Linear Slot Diffusers

**Series 6600-30-6**  
**T-bar Lay-in → 1/2" Border**

Supply - 1/2" Border - T-bar Lay-in  
 Model 6650-30-6 - 1/2" Slot Width  
 Model 6675-30-6 - 3/4" Slot Width  
 Model 6610-30-6 - 1" Slot Width

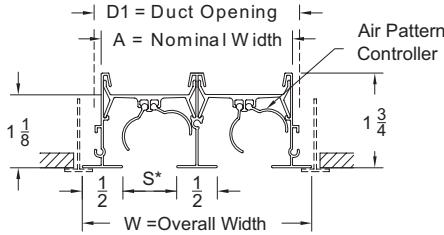

**End Border**  
 Model 6600-30-6

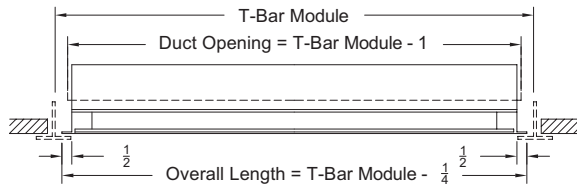
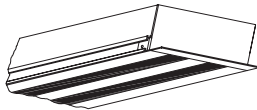

**End Cap**  
 Model 6600-30-6

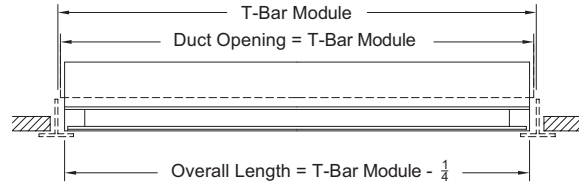
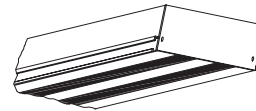

**Air Deflection Patterns**

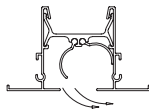

Right Horizontal

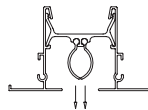

Vertical Projection

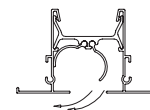

Left Horizontal

Model 6650								
S = 1/2" Slot	Number of Air Slots							
	1	2	3	4	5	6	7	8
A	1 1/4	2 1/2	3 3/4	5	6 5/16	7 1/2	8 3/4	10
D1	1 5/8	2 7/8	4 1/8	5 3/8	6 5/8	7 7/8	9 1/8	10 3/8
W	1 1/2	2 3/4	4	5 1/4	6 1/2	7 3/4	9	10 1/4

Model 6610								
S = 1" Slot	Number of Air Slots							
	1	2	3	4	5	6	7	8
A	1 3/4	3 1/2	5 1/4	7	8 3/4	10 1/2	12 1/4	14
D1	2 1/8	3 7/8	5 5/8	7 3/8	9 1/8	10 7/8	12 5/8	14 3/8
W	2	3 3/4	5 1/2	7 1/4	9	10 3/4	12 1/2	14 1/4

Model 6675								
S = 3/4" Slot	Number of Air Slots							
	1	2	3	4	5	6	7	8
A	1 1/2	3	4 1/2	6	7 1/2	9	10 1/2	12
D1	1 7/8	3 3/8	4 7/8	6 3/8	7 7/8	9 3/8	10 7/8	12 3/8
W	1 3/4	3 1/4	4 3/4	6 1/4	7 3/4	9 1/4	10 3/4	12 1/4

6600R return has same dimensions as 6600 supply but provided without pattern controllers to reduce sound and pressure drop



# LSD - Linear Slot Diffusers

8/2006

Linear Slot Diffusers

LSD

## Series 6600-11-1 1 1/8" Border → Face Screw Mounting

Supply - 1 1/8" Border  
Model 6650-11-1 - 1/2" Slot Width  
Model 6675-11-1 - 3/4" Slot Width  
Model 6610-11-1 - 1" Slot Width

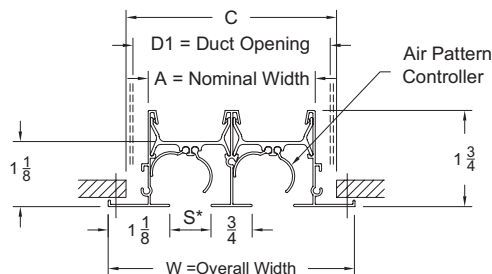

## Series 6600-12-1 1 1/8" Border → Concealed Surface Mount

Supply - 1 1/8" Border  
Model 6650-12-1 - 1/2" Slot Width  
Model 6675-12-1 - 3/4" Slot Width  
Model 6610-12-1 - 1" Slot Width

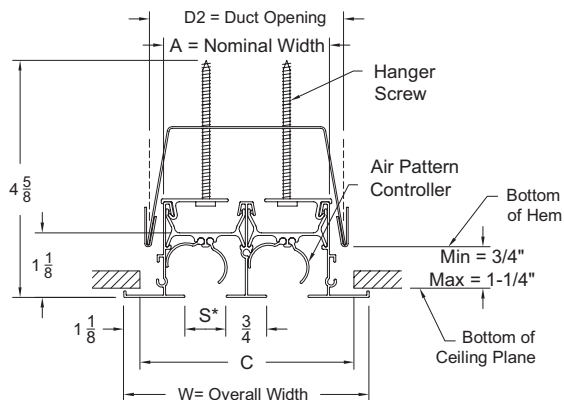

### End Border

Note: For the 6600-12-1, the BP/BPI plenum must be installed with 3/4" minimum/ 1-1/4" Maximum opening between the bottom of the ceiling plane and the bottom of the hem of the BP/BPI plenum

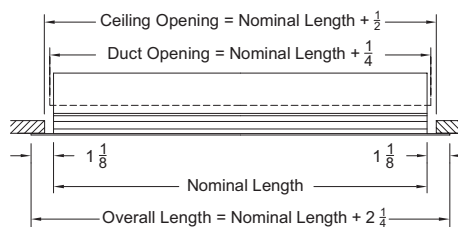
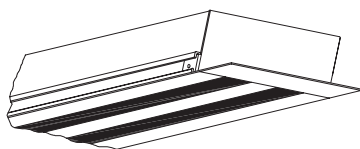

### Air Deflection Patterns

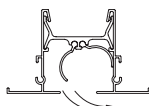

Right Horizontal

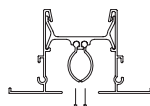

Vertical Projection

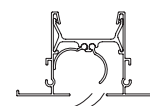

Left Horizontal

Model 6650 (6650-11-1 & 6650-12-1)	
S = 1/2" Slot	Number of Air Slots
A	1 1/4 2 1/2 3 3/4 5 6 1/4 7 1/2 8 3/4 10
D1	1 5/8 2 7/8 4 1/8 5 3/8 6 5/8 7 7/8 9 1/8 10 3/8
D2	1 7/8 3 1/8 4 3/8 5 5/8 6 7/8 8 1/8 9 3/8 10 5/8
C	2 3 1/4 4 1/2 5 3/4 7 8 1/4 9 1/2 10 3/4
W	2 3/4 4 5 1/4 6 1/2 7 3/4 9 10 1/4 11 1/2

Model 6610 (6610-11-1 & 6610-12-1)	
S = 1" Slot	Number of Air Slots
A	1 3/4 3 1/2 5 1/4 7 8 3/4 10 1/2 12 1/4 14
D1	2 1/8 3 7/8 5 5/8 7 3/8 9 1/8 10 7/8 12 5/8 14 3/8
D2	2 3/8 4 1/8 5 7/8 7 5/8 9 3/8 11 1/8 12 7/8 14 5/8
C	2 1/2 4 1/4 6 7 3/4 9 1/2 11 1/4 13 14 3/4
W	3 1/4 5 6 3/4 8 1/2 10 1/4 12 13 3/4 15 1/2

Model 6675 (6675-11-1 & 6675-12-1)	
S = 3/4" Slot	Number of Air Slots
A	1 1/2 3 4 1/2 6 7 1/2 9 10 1/2 12
D1	1 7/8 3 3/8 4 7/8 6 3/8 7 7/8 9 3/8 10 7/8 12 3/8
D2	2 1/8 3 5/8 5 1/8 6 5/8 8 1/8 9 5/8 11 1/8 12 5/8
C	2 1/4 3 3/4 5 1/4 6 3/4 8 1/4 9 3/4 11 1/4 12 3/4
W	3 4 1/2 6 7 1/2 9 10 1/2 12 13 1/2

6600R return has same dimensions as 6600 supply but provided without pattern controllers to reduce sound and pressure drop

# LSD - Linear Slot Diffusers

Linear Slot Diffusers

LSD

**Series 6600-40-7**  
25/32" Border → Concealed Spline

Supply - Concealed Spline  
Model 6650-40-7 - 1/2" Slot Width  
Model 6675-40-7 - 3/4" Slot Width  
Model 6610-40-7 - 1" Slot Width

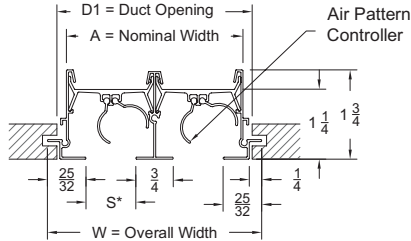

**Series 6600-42-7**  
25/32" Border → Concealed Spline → Concealed Mount

Supply - Concealed Spline  
Model 6650-42-7 - 1/2" Slot Width  
Model 6675-42-7 - 3/4" Slot Width  
Model 6610-42-7 - 1" Slot Width

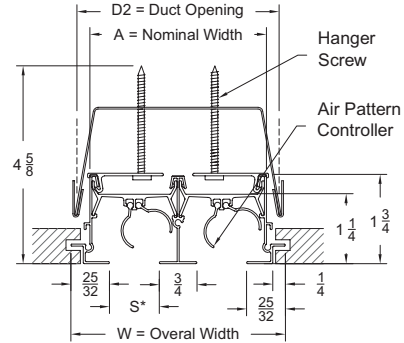

**End Border**  
Model 6600-40-7 & 6600-42-7

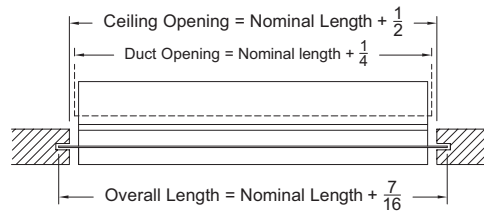
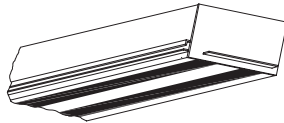

**Air Deflection Patterns**

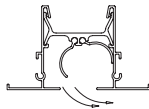

Right Horizontal

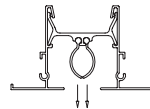

Vertical Projection

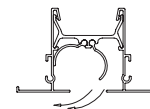

Left Horizontal

Model 6650 (6650-40-7 & 6650-42-7)								
S = 1/2" Slot	Number of Air Slots							
	1	2	3	4	5	6	7	8
A	1 1/4	2 1/2	3 3/4	5	6 1/4	7 1/2	8 3/4	10
D1	1 5/8	2 7/8	4 1/8	5 3/8	6 5/8	7 7/8	9 1/8	10 3/8
D2	1 7/8	3 1/8	4 3/8	5 5/8	6 7/8	8 1/8	9 3/8	10 5/8
W	2 1/16	3 5/16	4 9/16	5 13/16	7 1/16	8 5/16	9 9/16	10 13/16

Model 6610 (6610-40-7 & 6610-42-7)								
S = 1" Slot	Number of Air Slots							
	1	2	3	4	5	6	7	8
A	1 3/4	3 1/2	5 1/4	7	8 3/4	10 1/2	12 1/4	14
D1	2 1/8	3 7/8	5 5/8	7 3/8	9 1/8	10 7/8	12 5/8	14 3/8
D2	2 3/8	4 1/8	5 7/8	7 5/8	9 3/8	11 1/8	12 7/8	14 5/8
W	2 9/16	4 5/16	6 1/16	7 13/16	9 9/16	11 5/16	13 1/16	14 13/16

Model 6675 (6675-40-7 & 6675-42-7)								
S = 3/4" Slot	Number of Air Slots							
	1	2	3	4	5	6	7	8
A	1 1/2	3	4 1/2	6	7 1/2	9	10 1/2	12
D1	1 7/8	3 3/8	4 7/8	6 3/8	7 7/8	9 3/8	10 7/8	12 3/8
D2	2 1/8	3 5/8	5 1/8	6 5/8	8 1/8	9 5/8	11 1/8	12 5/8
W	2 5/16	3 13/16	5 5/16	6 13/16	8 5/16	9 13/16	11 5/16	12 13/16

6600R return has same dimensions as 6600 supply but provided without pattern controllers to reduce sound and pressure drop

# LSD - Linear Slot Diffusers

8/2006

Linear Slot Diffusers

LSD

## Series 6600-40-8 Drop Face

### Supply - Drop Face

Model 6650-40-8 - 1/2" Slot Width

Model 6675-40-8 - 3/4" Slot Width

Model 6610-40-8 - 1" Slot Width

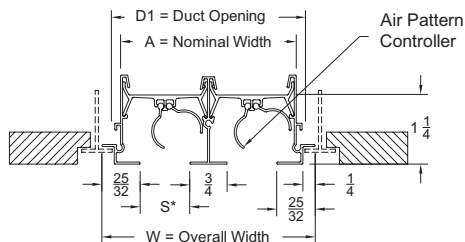

## End Border Model 6600-40-8

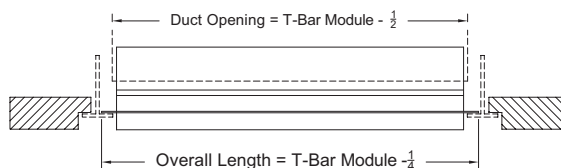
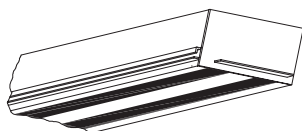

## Air Deflection Patterns

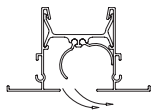

Right Horizontal

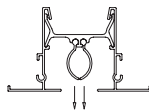

Vertical Projection

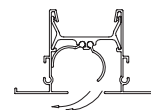

Left Horizontal

Model 6650 (6650-40-8)									
S = 1/2" Slot	Number of Air Slots								
	1	2	3	4	5	6	7	8	
A	1 1/4	2 1/2	3 3/4	5	6 1/4	7 1/2	8 3/4	10	
D1	1 5/8	2 7/8	4 1/8	5 3/8	6 5/8	7 7/8	9 1/8	10 3/8	
D2	1 7/8	3 1/8	4 3/8	5 5/8	6 7/8	8 1/8	9 3/8	10 5/8	
W	2 1/16	3 5/16	4 9/16	5 13/16	7 1/16	8 5/16	9 9/16	10 13/16	

Model 6610 (6610-40-8)									
S = 1" Slot	Number of Air Slots								
	1	2	3	4	5	6	7	8	
A	1 3/4	3 1/2	5 1/4	7	8 3/4	10 1/2	12 1/4	14	
D1	2 1/8	3 7/8	5 5/8	7 3/8	9 1/8	10 7/8	12 5/8	14 3/8	
D2	2 3/8	4 1/8	5 7/8	7 5/8	9 3/8	11 1/8	12 7/8	14 5/8	
W	2 9/16	4 5/16	6 1/16	7 13/16	9 9/16	11 5/16	13 1/16	14 13/16	

Model 6675 (6675-40-8)									
S = 3/4" Slot	Number of Air Slots								
	1	2	3	4	5	6	7	8	
A	1 1/2	3	4 1/2	6	7 1/2	9	10 1/2	12	
D1	1 7/8	3 3/8	4 7/8	6 3/8	7 7/8	9 3/8	10 7/8	12 3/8	
D2	2 1/8	3 5/8	5 1/8	6 5/8	8 1/8	9 5/8	11 1/8	12 5/8	
W	2 5/16	3 13/16	5 5/16	6 13/16	8 5/16	9 13/16	11 5/16	12 13/16	

6600R return has same dimensions as 6600 supply but provided without pattern controllers to reduce sound and pressure drop

# LSD - Linear Slot Diffusers

**Series 6600-40-9**  
**Narrow Tee**

Supply - Narrow Tee - 9/16" Face  
 Model 6650-40-9 - 1/2" Slot Width  
 Model 6675-40-9 - 3/4" Slot Width  
 Model 6610-40-9 - 1" Slot Width

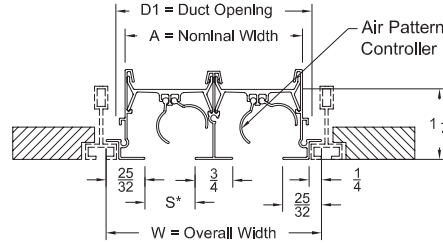

**End Border**  
**Model 6600-40-9**

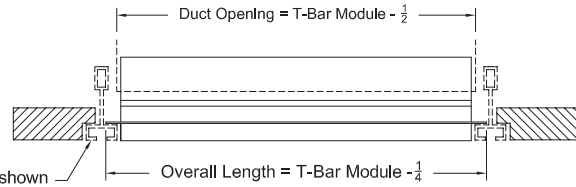
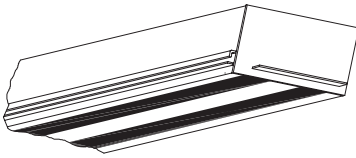

6600-40-9 Model shown with Bolt Grid as an alternate application

**Air Deflection Patterns**

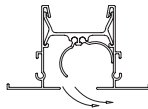

Right Horizontal

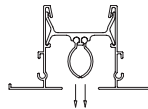

Vertical Projection

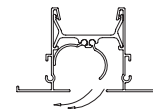

Left Horizontal

Model 6650 (6650-40-9)									
S = 1/2" Slot	Number of Air Slots								
	1	2	3	4	5	6	7	8	
A	1 1/4	2 1/2	3 3/4	5	6 1/4	7 1/2	8 3/4	10	
D1	1 5/8	2 7/8	4 1/8	5 3/8	6 5/8	7 7/8	9 1/8	10 3/8	
W	2 1/16	3 5/16	4 9/16	5 13/16	7 1/16	8 5/16	9 9/16	10 13/16	

Model 6610 (6610-40-9)									
S = 1" Slot	Number of Air Slots								
	1	2	3	4	5	6	7	8	
A	1 3/4	3 1/2	5 1/4	7	8 3/4	10 1/2	12 1/4	14	
D1	2 1/8	3 7/8	5 5/8	7 3/8	9 1/8	10 7/8	12 5/8	14 3/8	
W	2 9/16	4 5/16	6 1/16	7 13/16	9 9/16	11 5/16	13 1/16	14 13/16	

Model 6675 (6675-40-9)									
S = 3/4" Slot	Number of Air Slots								
	1	2	3	4	5	6	7	8	
A	1 1/2	3	4 1/2	6	7 1/2	9	10 1/2	12	
D1	1 7/8	3 3/8	4 7/8	6 3/8	7 7/8	9 3/8	10 7/8	12 3/8	
W	2 5/16	3 13/16	5 5/16	6 13/16	8 5/16	9 13/16	11 5/16	12 13/16	

6600R return has same dimensions as 6600 supply but provided without pattern controllers to reduce sound and pressure drop

# LSD - Linear Slot Diffusers

8/2006

Linear Slot Diffusers

LSD

**Series 6600-22-73-1**  
 Concealed Spline/Plaster Frame ➔ 3/4" Border w/ Concealed Mount

Supply - 3/4" Border - Concealed Spline/Plaster Frame  
 Model 6650-22-73 - 1/2" Slot Width  
 Model 6675-22-73 - 3/4" Slot Width  
 Model 6610-22-73 - 1" Slot Width

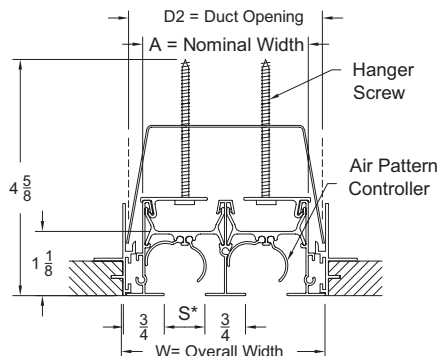

**Series 6600-22-74-1**  
 Wall Concealed Spline/Plaster Frame ➔ 3/4" Border w/ Concealed Mount

Supply - 3/4" Border - Concealed Spline/Plaster & Wall Frame  
 Model 6650-22-74 - 1/2" Slot Width  
 Model 6675-22-74 - 3/4" Slot Width  
 Model 6610-22-74 - 1" Slot Width

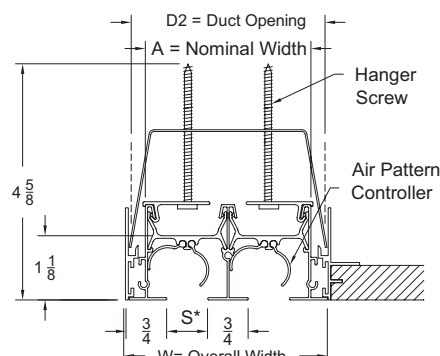

**End Border**  
 Models 6600-22-73 & 6600-22-74

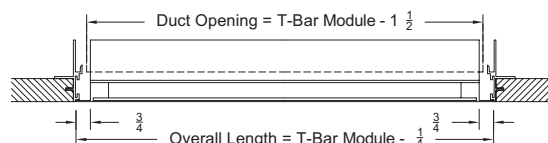
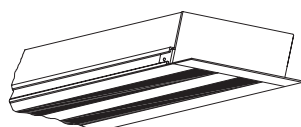

## Air Deflection Patterns

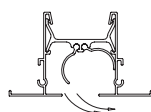

Right Horizontal

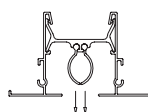

Vertical Projection

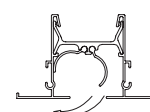

Left Horizontal

Model 6650								
S = 1/2" Slot	Number of Air Slots							
	1	2	3	4	5	6	7	8
A	1 1/4	2 1/2	3 3/4	5	6 1/4	7 1/2	8 3/4	10
D1	1 5/8	2 7/8	4 1/8	5 3/8	6 5/8	7 7/8	9 1/5	10 3/8
W	2	3 1/4	4 1/4	5 3/4	7	8 1/4	9 1/2	10 3/4

Model 6610								
S = 1" Slot	Number of Air Slots							
	1	2	3	4	5	6	7	8
A	1 3/4	3 1/2	5 1/4	7	8 3/4	10 1/2	12 1/4	14
D1	2 1/8	3 7/8	5 5/8	7 3/8	9 1/8	10 7/8	12 5/8	14 3/8
W	2 1/2	4 1/4	6	7 3/4	9 1/2	11 1/4	13	14 3/4

Model 6675								
S = 3/4" Slot	Number of Air Slots							
	1	2	3	4	5	6	7	8
A	1 1/2	3	4 1/2	6	7 1/2	9	10 1/2	12
D1	1 7/8	3 3/8	4 7/8	6 3/8	7 7/8	9 3/8	10 7/8	12 3/8
W	2 1/4	3 3/4	5 1/4	6 3/4	8 1/4	9 3/4	11 1/4	12 3/4

6600R return has same dimensions as 6600 supply but provided without pattern controllers to reduce sound and pressure drop

### Notes for Series 6600

1. Available Finishes	2. Available Accessories	3. Construction Details
<p><b>Standard Finish:</b>                      20 White frame with black pattern controller</p> <p><b>Optional Finish</b>                      21 Clear anodized with black pattern controller                      28 Custom color</p>	<p>Mitered Corners (45°, 90° and 135°) .....335</p> <p>Replacement End Caps</p> <p>Insulated Boot Plenums</p> <p>Non-Insulated Boot Plenums</p> <p><b>Note:</b>                      BP Boot Plenums are shipped separate for field installation</p>	<ul style="list-style-type: none"> <li>Sizes available in only 1-8 slots</li> <li>Slot widths available 1/2" (6650), 3/4" (6675), and 1" (6610)</li> <li>Longest single section is 8 feet</li> <li>Continuous lengths are made in sections</li> </ul>

## Series 6600 - Performance

## 6650 1/2" Slot - CFM Per Linear Foot

Slots	Static Pressure	Horizontal Vertical	0.005	0.021	0.047	0.083	0.130	0.188	0.255	0.334	0.422	0.521
			0.004	0.015	0.033	0.058	0.091	0.132	0.179	0.234	0.295	0.365
1		CFM/LF	5	10	15	20	25	30	35	40	45	50
		Horizontal Throw, ft	1-1-6	3-6-12	6-10-14	10-12-17	11-13-19	12-14-20	13-16-22	14-17-24	14-18-25	15-19-26
		Vertical Throw, ft	2	7	9	11	12	13	14	15	16	17
		Horizontal NC	<15	<15	<15	17	22	27	30	34	36	38
		Vertical NC	<15	<15	<15	<15	<15	15	18	22	24	26
2		CFM/LF	10	20	30	40	50	60	70	80	90	100
		Horizontal Throw, ft	1-2-8	4-8-17	8-14-20	14-17-24	15-19-26	17-20-29	18-22-31	19-24-33	20-25-35	22-36-37
		Vertical Throw, ft	3	9	13	15	17	18	20	21	23	24
		Horizontal NC	<15	<15	<15	20	25	30	33	37	39	41
		Vertical NC	<15	<15	<15	<15	<15	18	21	25	27	29
3		CFM/LF	15	30	45	60	75	90	105	120	135	150
		Horizontal Throw, ft	2-4-13	6-13-20	13-18-25	17-20-29	19-23-32	20-25-35	22-27-38	18-22-31	19-24-33	20-25-35
		Vertical Throw, ft	5	11	16	18	21	23	24	26	28	29
		Horizontal NC	<15	<15	15	22	27	32	35	39	41	43
		Vertical NC	<15	<15	<15	<15	15	20	23	27	29	31
4		CFM/LF	20	40	60	80	100	120	140	160	180	200
		Horizontal Throw, ft	3-6-15	10-15-24	15-20-29	19-24-33	22-26-37	24-29-41	26-31-44	27-33-47	29-35-50	31-37-53
		Vertical Throw, ft	5	13	18	21	24	26	28	30	32	34
		Horizontal NC	<15	<15	17	24	29	33	36	40	42	44
		Vertical NC	<15	<15	<15	<15	17	21	24	28	30	32
5		CFM/LF	25	50	75	100	125	150	175	200	225	250
		Horizontal Throw, ft	3-7-16	11-16-25	16-23-32	22-26-3	24-30-42	26-32-46	29-35-49	31-37-53	32-40-56	34-42-59
		Vertical Throw, ft	6	19	23	26	29	32	34	37	39	41
		Horizontal NC	<15	<15	19	26	31	35	37	41	43	45
		Vertical NC	<15	<15	<15	<15	19	23	25	29	31	33
6		CFM/LF	30	60	90	120	150	180	210	240	270	300
		Horizontal Throw, ft	4-8-20	14-20-29	20-25-35	24-29-41	26-32-46	29-35-50	31-38-54	33-41-58	35-43-61	37-56-65
		Vertical Throw, ft	6	16	23	26	29	32	34	37	39	41
		Horizontal NC	<15	17	20	27	32	36	38	42	44	46
		Vertical NC	<15	<15	<15	15	20	24	26	30	32	35
7		CFM/LF	35	70	105	140	175	210	245	280	315	350
		Horizontal Throw, ft	5-9-18	12-18-31	18-27-38	24-31-44	29-35-49	31-38-54	34-41-59	36-44-63	38-47-66	40-49-70
		Vertical Throw, ft	7	17	24	28	31	34	37	40	42	45
		Horizontal NC	<15	18	21	28	33	37	39	43	45	47
		Vertical NC	<15	<15	<15	16	21	25	37	331	33	35
8		CFM/LF	40	80	120	160	200	240	280	320	360	400
		Horizontal Throw, ft	6-10-19	13-19-33	19-29-41	26-33-47	31-37-53	33-41-58	36-44-63	39-47-67	41-50-71	43-53-75
		Vertical Throw, ft	7	18	26	30	34	37	40	43	45	48
		Horizontal NC	<15	20	22	29	34	39	40	44	46	48
		Vertical NC	<15	<15	<15	17	22	27	28	32	34	36

See Page LSD-179 for Performance Notes

# LSD - Linear Slot Diffusers

8/2006

## Series 6600 - Performance

### 6675 3/4" Slot - CFM Per Linear Foot

Slots	Static Pressure	Horizontal Vertical	0.011	0.024	0.042	0.066	0.095	0.129	0.168	0.213	0.263	0.318
			0.007	0.014	0.025	0.040	0.057	0.077	0.101	0.128	0.158	0.191
1		CFM/LF	10	15	20	25	30	35	40	45	50	55
		Horizontal Throw, ft	1-2-6	2-4-14	3-6-22	4-10-24	6-14-27	9-19-29	11-22-31	14-26-33	18-24-35	20-26-36
		Vertical Throw, ft	2	6	10	12	13	14	15	16	17	18
		Horizontal NC	<15	<15	<15	15	19	23	25	28	31	33
		Vertical NC	<15	<15	<15	<15	<15	<15	<15	16	19	21
2		CFM/LF	20	30	40	50	60	70	80	90	100	110
		Horizontal Throw, ft	1-3-10	3-6-22	5-10-29	7-16-35	10-22-38	14-26-41	19-29-44	22-33-46	25-35-49	27-36-51
		Vertical Throw, ft	4	8	14	17	18	20	21	23	24	25
		Horizontal NC	<15	<15	<15	18	22	26	28	31	34	36
		Vertical NC	<15	<15	<15	<15	<15	<15	<15	16	19	22
3		CFM/LF	30	45	60	75	90	105	120	135	150	165
		Horizontal Throw, ft	1-3-13	3-7-27	6-13-36	9-20-41	13-27-44	17-32-48	23-36-51	27-39-54	30-41-57	33-43-60
		Vertical Throw, ft	4	10	17	21	23	24	26	28	29	31
		Horizontal NC	<15	<15	<15	20	24	28	30	33	35	37
		Vertical NC	<15	<15	<15	<15	<15	<15	16	18	21	25
4		CFM/LF	40	60	80	100	120	140	160	180	200	220
		Horizontal Throw, ft	4-10-24	10-18-36	16-24-42	20-30-47	24-36-51	28-39-55	32-42-59	36-44-63	38-47-66	40-49-70
		Vertical Throw, ft	5	11	20	24	26	28	30	32	34	35
		Horizontal NC	<15	15	16	22	25	30	31	35	37	39
		Vertical NC	<15	<15	<15	<15	<15	18	19	23	25	27
5		CFM/LF	50	75	100	125	150	175	200	225	250	275
		Horizontal Throw, ft	10-15-30	15-23-41	20-30-47	25-37-52	30-41-57	35-44-62	38-47-66	41-50-70	43-52-74	45-55-78
		Vertical Throw, ft	6	13	22	27	29	31	34	36	38	39
		Horizontal NC	<15	16	17	23	26	32	33	36	38	40
		Vertical NC	<15	<15	<15	<15	<15	20	21	24	20	28
6		CFM/LF	60	90	120	150	180	210	240	270	300	330
		Horizontal Throw, ft	10-15-29	15-22-44	20-29-51	24-37-57	29-44-63	34-48-68	39-51-73	44-54-77	47-57-81	49-60-85
		Vertical Throw, ft	6	14	24	29	32	34	37	39	41	43
		Horizontal NC	<15	17	19	24	28	33	34	37	39	41
		Vertical NC	<15	<15	<15	<15	16	21	22	25	27	29
7		CFM/LF	70	105	140	175	210	245	280	315	350	385
		Horizontal Throw, ft	11-16-32	16-24-48	21-32-55	26-40-63	32-48-68	37-52-73	42-55-78	48-59-83	51-62-88	53-65-92
		Vertical Throw, ft	7	15	26	31	34	37	40	42	45	47
		Horizontal NC	16	18	20	24	29	34	35	38	40	42
		Vertical NC	<15	<15	<15	<15	17	22	23	26	28	30
8		CFM/LF	80	120	160	200	240	280	320	360	400	440
		Horizontal Throw, ft	11-17-34	17-25-51	23-34-59	28-42-66	34-51-73	40-55-78	45-59-84	51-63-89	54-66-94	57-70-9
		Vertical Throw, ft	7	16	28	34	37	40	43	45	48	50
		Horizontal NC	18	19	22	25	30	35	37	39	41	43
		Vertical NC	<15	<15	<15	<15	18	23	25	27	29	31

See Page LSD-179 for Performance Notes

Linear Slot Diffusers

LSD

## Series 6600 - Performance

## 6610 1" Slot - CFM Per Linear Foot

Slots	Static Pressure	Horizontal Vertical	0.008 0.003	0.030 0.012	0.047 0.020	0.068 0.028	0.092 0.037	0.120 0.04	0.152 0.061	0.188 0.076	0.227 0.092	0.270 0.109
1	CFM/LF		10	20	25	30	35	40	45	50	55	60
	Horizontal Throw, ft		1-2-6	3-6-22	4-10-24	6-14-27	9-19-29	11-22-31	14-23-33	18-24-35	20-26-36	22-27-38
	Vertical Throw, ft		2	10	12	13	14	15	16	17	18	18
	Horizontal NC		<15	<15	<15	<15	19	22	24	26	28	30
	Vertical NC		<15	<15	<15	<15	<15	<15	<15	<15	16	18
2	CFM/LF		20	40	50	60	70	80	90	100	110	120
	Horizontal Throw, ft		1-3-10	5-10-29	7-16-35	10-22-38	14-26-41	19-29-44	22-33-46	25-35-49	27-36-51	29-38-54
	Vertical Throw, ft		4	14	17	18	20	21	23	24	25	26
	Horizontal NC		<15	<15	<15	<15	21	25	27	29	31	33
	Vertical NC		<15	<15	<15	<15	<15	<15	15	17	19	21
3	CFM/LF		30	60	75	90	105	120	135	150	165	180
	Horizontal Throw, ft		3-7-18	12-18-36	15-23-41	18-27-44	21-32-48	24-26-51	27-39-54	30-41-57	33-43-60	36-44-63
	Vertical Throw, ft		4	17	21	23	24	26	28	29	31	32
	Horizontal NC		<15	<15	<15	17	22	27	28	30	32	34
	Vertical NC		<15	<15	<15	<15	<15	15	16	18	20	22
4	CFM/LF		40	80	100	120	140	160	180	200	220	240
	Horizontal Throw, ft		4-10-24	16-24-42	20-30-47	24-36-51	28-39-55	32-42-59	36-44-63	38-47-66	40-49-70	42-51-73
	Vertical Throw, ft		5	20	24	26	28	30	32	34	35	37
	Horizontal NC		<15	<15	15	19	24	29	30	32	34	36
	Vertical NC		<15	<15	<15	<15	<15	17	18	20	22	24
5	CFM/LF		50	100	125	150	175	200	225	250	275	300
	Horizontal Throw, ft		10-15-30	20-30-47	25-37-52	30-41-57	35-44-62	38-47-66	41-50-70	43-52-74	45-55-78	47-57-81
	Vertical Throw, ft		6	24	29	32	34	37	39	41	43	45
	Horizontal NC		<15	<15	16	21	25	31	32	34	35	37
	Vertical NC		<15	<15	<15	<15	<15	19	20	22	23	25
6	CFM/LF		60	120	150	180	210	240	270	300	330	360
	Horizontal Throw, ft		10-15-29	20-29-51	24-37-57	29-44-63	34-48-68	39-51-73	44-54-77	47-57-81	49-60-85	51-63-89
	Vertical Throw, ft		6	24	29	32	34	37	39	41	43	45
	Horizontal NC		<15	15	17	22	27	33	34	35	36	38
	Vertical NC		<15	<15	<15	<15	<15	21	22	23	24	26
7	CFM/LF		70	140	175	210	245	280	315	350	385	420
	Horizontal Throw, ft		11-16-32	21-32-55	26-40-62	32-48-68	37-52-73	42-55-78	48-59-83	51-62-88	53-65-92	55-68-96
	Vertical Throw, ft		7	26	31	34	37	40	42	45	47	49
	Horizontal NC		<15	16	18	24	28	34	36	37	37	39
	Vertical NC		<15	<15	<15	<15	16	22	24	25	25	27
8	CFM/LF		80	160	200	240	280	320	360	400	440	480
	Horizontal Throw, ft		11-17-34	23-34-59	28-42-66	34-51-73	40-55-78	45-59-84	51-63-89	54-66-94	57-70-98	59-73-103
	Vertical Throw, ft		7	28	34	37	40	43	45	48	50	52
	Horizontal NC		<15	16	20	26	30	35	37	38	39	41
	Vertical NC		<15	<15	<15	<15	18	23	25	26	27	29

See Page LSD-179 for Performance Notes



# LSD - Linear Slot Diffusers

8/2006

## Series 6600 - Performance

### 6650R - 1/2" Slot Width

Number of Slots	Negative Ps Inches of Water	.02	.04	.06	.08	.10	.15
1	CFM/Ft.	15	20	25	30	35	40
Ak/Ft=.03	NC	-	20	27	32	37	41
2	CFM/Ft.	35	50	60	70	80	95
Ak/Ft=.06	NC	-	22	27	32	37	41
3	CFM/Ft.	55	80	95	110	125	150
Ak/Ft=.09	NC	-	23	28	33	37	42
4	CFM/Ft.	70	100	120	140	155	190
Ak/Ft=.12	NC	-	24	30	34	37	44
5	CFM/Ft.	90	135	155	180	200	245
Ak/Ft=.15	NC	-	25	30	34	37	44
6	CFM/Ft.	110	155	195	220	245	300
Ak/Ft=.18	NC	-	26	33	37	40	96
7	CFM/Ft.	130	185	225	260	290	355
Ak/Ft=.21	NC	-	27	33	37	41	47
8	CFM/Ft.	140	200	245	280	310	385
Ak/Ft=.24	NC	-	28	34	38	42	48

### 6675R - 3/4" Slot Width

Number of Slots	Negative Ps Inches of Water	.02	.04	.06	.08	.10	.15
1	CFM/Ft.	25	35	45	50	55	70
Ak/Ft=.02	NC	-	21	29	32	35	42
2	CFM/Ft.	55	80	90	100	110	135
Ak/Ft=.08	NC	-	25	29	32	35	42
3	CFM/Ft.	90	115	140	160	180	220
Ak/Ft=.12	NC	-	26	32	36	40	46
4	CFM/Ft.	100	140	175	200	225	275
Ak/Ft=.12	NC	-	27	34	38	41	47
5	CFM/Ft.	140	185	225	260	290	360
Ak/Ft=.16	NC	-	28	34	38	42	48
6	CFM/Ft.	160	225	275	320	360	440
Ak/Ft=.20	NC	-	29	35	40	43	49
7	CFM/Ft.	175	250	305	350	395	480
Ak/Ft=.24	NC	-	30	36	40	44	50
8	CFM/Ft.	200	285	350	400	450	545
Ak/Ft=.32	NC	-	31	37	41	45	51

### 6610R - 1" Slot Width

Number of Slots	Negative Ps Inches of Water	.02	.04	.06	.08	.10	.15
1	CFM/Ft.	35	50	60	70	80	95
Ak/Ft=.06	NC	-	25	31	36	40	45
2	CFM/Ft.	70	100	125	140	155	190
Ak/Ft=.11	NC	-	27	33	37	41	47
3	CFM/Ft.	105	150	185	210	235	285
Ak/Ft=.17	NC	-	29	35	39	43	49
4	CFM/Ft.	140	200	250	280	310	380
Ak/Ft=.23	NC	-	31	37	41	45	51
5	CFM/Ft.	175	250	300	350	390	475
Ak/Ft=.28	NC	-	32	38	42	46	52
6	CFM/Ft.	210	300	375	420	465	570
Ak/Ft=.33	NC	-	33	40	43	47	53
7	CFM/Ft.	245	350	425	490	545	665
Ak/Ft=.39	NC	-	34	41	44	47	54
8	CFM/Ft.	280	400	475	560	620	760
Ak/Ft=.44	NC	-	35	42	45	48	55

See Page LSD-179 for Performance Notes

Linear Slot Diffusers

LSD

## Series 6600 - Performance Notes

### Performance Notes:

1. On units without BP/BPI plenums, pressure drop reported is across the diffuser element only. The field supply plenum pressure drop should be included when determining system fan requirements. A good approximation of the static pressure requirements can be calculated by adding the velocity pressure through the plenum inlet to the diffuser section pressure drop.
2. NC is based on a 4 ft section of diffuser. The following table should be used to calculate sound levels for lengths other than 4 ft.
3. To correct throws for lengths other than the 4 ft lengths used in determining catalog performance, throws should be adjusted per the following table:

NC Correction for Length					
Length (feet)	2	4	6	8	10
NC Correction	-2	+0	+2	+3	+5
Throw Correction Multiplier for Length					
Length (feet)	2	4	8	10	12
Throw Correction	.7	1.0	1.5	1.7	1.8

4. All pressures are in inches of water
5. Isothermal throws are given for terminal velocities of 150, 100 and 50 fpm, based upon 4 ft section
6. Vertical throw values are based on a 50 fpm terminal velocity
7. For Vertical supply, subtract one NC
8. For Returns minus pattern controllers, deduct 12 NC.
9. Throw values are based on a 1-way discharge from the slot. For 2-way discharges, throw is based upon the number and size of the slots throwing in each direction, with the total supply air flow split equally between all slots in the unit.
10. Data were collected in accordance to ASHRAE Standard 70-1991 "Method of Testing for Rating the Performance of Air Outlets and Inlets."



## Series 6600 - Installation

### Field Assembly

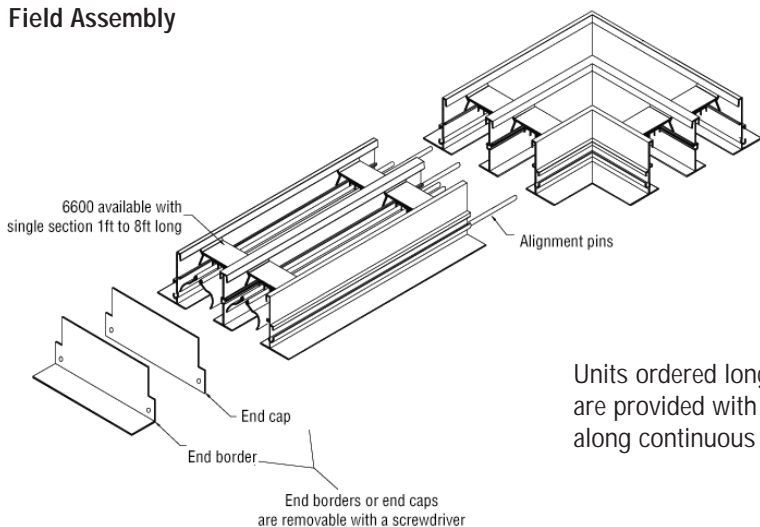

Units ordered longer than 8ft are shipped in multiple sections. Units are provided with alignment pins to keep the 6600 diffusers straight along continuous runs.

### Concealed Mounting

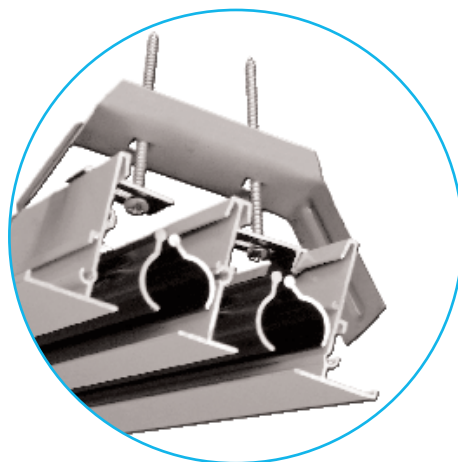
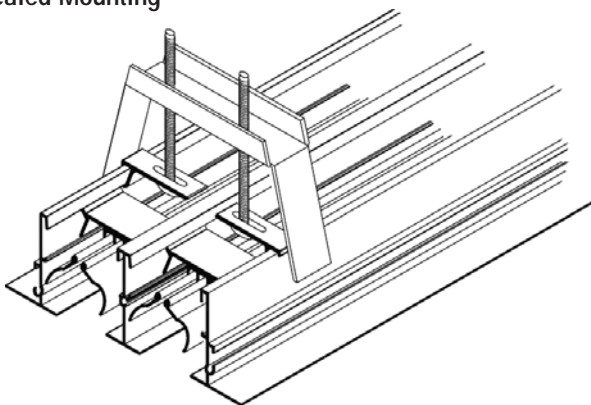

- Concealed Mounting makes installation easy
- Units are inserted into hemmed plenum and secured in place by tightening screws through the face

### Field Cutting

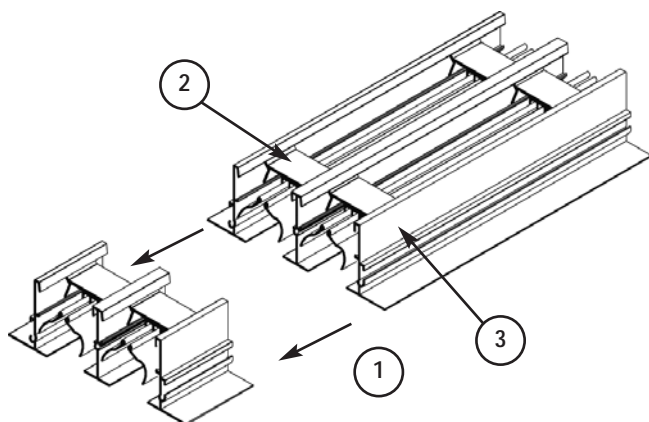

- 1 6600 can be field-cut to fit job conditions
- 2 Spacer is inserted to support pattern controllers
- 3 Screw or crimp to secure spacer in-place

## Series 6600 - Continuous Run Dimensions

MODELS 6650-11-1 - Surface Mount

MODELS 6650-12-1 - Concealed Mounting

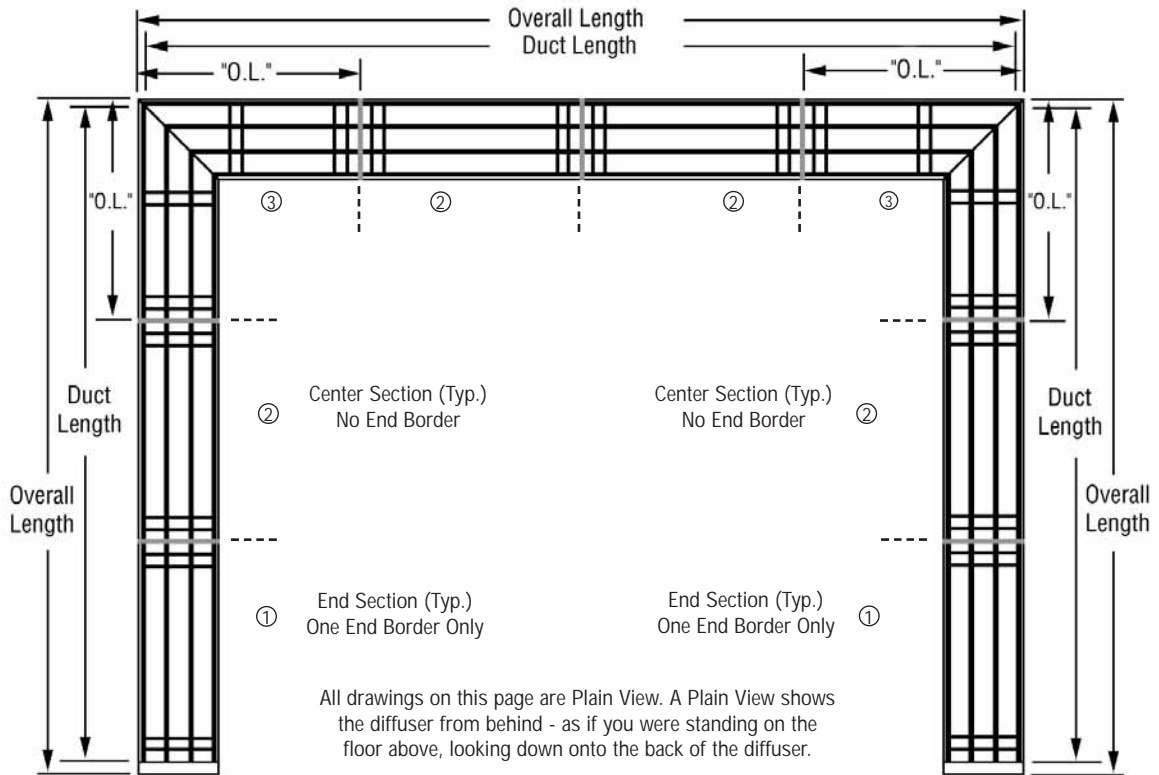

Linear Slot Diffusers



LSD

**Single Section, Two End Borders (Not Shown)**    ① **End Section, One End Border**    ② **Center Section, No End Borders**

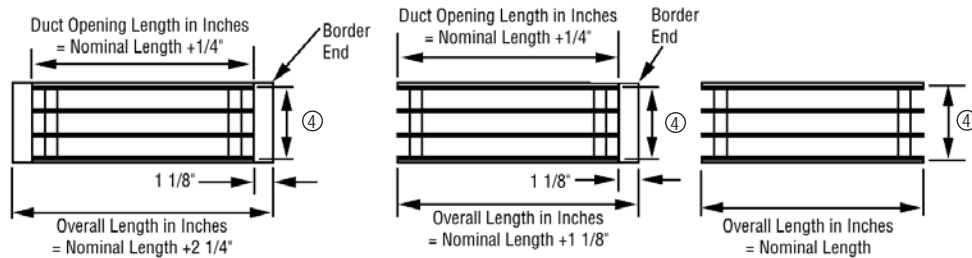

③ See Page LSD-98 for 90° Mitered Corner Dimensions (“O.L.”)

④ Note: For Duct Opening, Ceiling Opening, and Overall Width, see page LSD-83 - 90

# LSD - Linear Slot Diffusers

8/2006

Linear Slot Diffusers

LSD

## Mitered Corners → 45° Angle

Dimensions are in inches

Mitered Corners - 45° Angle - Extruded Aluminum  
 Slots: 1/2" (6650), 3/4" (6675) and 1" (6610)  
 Model MC6600-11-1 - 1 1/8" Border - Face Screw Mounting  
 Model MC6600-12-1 - 1 1/8" Border - Surface Mounting  
 Model MC6600-10-6 - 1 1/8" Border - T-bar Lay-in  
 Model MC6600-12-6 - 1 1/8" Border - T-bar Lay-in  
 Model MC6600-20-6 - 3/4" Border - T-bar Lay-in  
 Model MC6600-30-6 - 1/2" Border - T-bar Lay-in  
 Model MC6600-22-73 - 3/4" Border - Concealed Spline  
 Model MC6600-22-74 - 3/4" Border - Concealed Spline  
 Model MC6600-40-7 - 25/32" Border - Concealed Spline  
 Model MC6600-42-7 - 25/32" Border - Concealed Mounting  
 Model MC6600-40-8 - 25/32" Border - Drop Face  
 Model MC6600-40-9 - 25/32" Border - Donn Finline

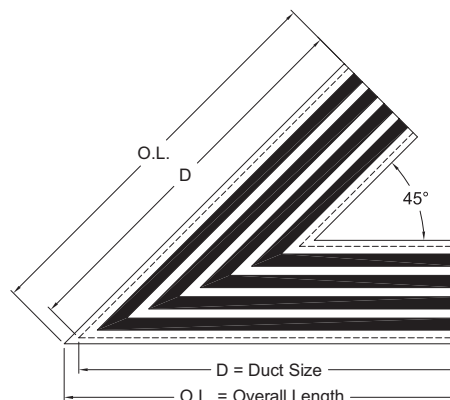

Number of Slots	Duct Size (All Models)	MC6600-11-1	MC6600-20-6	MC6600-30-6	MC6600-40-7	MC6600-40-9
		MC6600-12-1	MC6600-22-73		MC6600-42-7	
		MC6600-10-6	MC6600-22-74	MC6600-40-8		
		O.L.	O.L.	O.L.	O.L.	O.L.
1 - 2	24	24-3/4	24-27/32	24-5/16	24-29/32	24-29/32
3 - 5	36	36-3/4	36-27-32	36-5/16	36-29/32	36-29/32
6 - 8	48	48-3/4	48-27-32	48-5/16	48-29/32	48-29/32

## Mitered Corners → 90° Angle

Mitered Corners - 90° Angle - Extruded Aluminum  
 Slots: 1/2" (6650), 3/4" (6675) and 1" (6610)  
 Model MC6600-11-1 - 1 1/8" Border - Face Screw Mounting  
 Model MC6600-12-1 - 1 1/8" Border - Surface Mounting  
 Model MC6600-10-6 - 1 1/8" Border - T-bar Lay-in  
 Model MC6600-12-6 - 1 1/8" Border - T-bar Lay-in  
 Model MC6600-20-6 - 3/4" Border - T-bar Lay-in  
 Model MC6600-30-6 - 1/2" Border - T-bar Lay-in  
 Model MC6600-22-73 - 3/4" Border - Concealed Spline  
 Model MC6600-22-74 - 3/4" Border - Concealed Spline  
 Model MC6600-40-7 - 25/32" Border - Concealed Spline  
 Model MC6600-42-7 - 25/32" Border - Concealed Mounting  
 Model MC6600-40-8 - 25/32" Border - Drop Face  
 Model MC6600-40-9 - 25/32" Border - Donn Finline

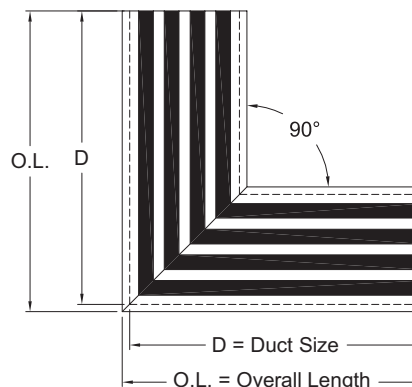

Number of Slots	Duct Size (All Models)	MC6600-11-1	MC6600-20-6	MC6600-30-6	MC6600-40-7	MC6600-40-9
		MC6600-12-1	MC6600-22-73		MC6600-42-7	
		MC6600-10-6	MC6600-22-74	MC6600-40-8		
		O.L.	O.L.	O.L.	O.L.	O.L.
1 - 3	12	12 23/32	12 11/32	12 1/8	12 3/8	12 3/8
4 - 8	24	24 23 32	24 11/32	24 1/8	24 3/8	24 3/8

## Mitered Corners → 135° Angle

### Mitered Corners - 135° Angle - Extruded Aluminum

Slots: 1/2" (6650), 3/4" (6675) and 1" (6610)

Model MC6600-11-1 - 1 1/8" Border - Face Screw Mounting

Model MC6600-12-1 - 1 1/8" Border - Surface Mounting

Model MC6600-10-6 - 1 1/8" Border - T-bar Lay-in

Model MC6600-12-6 - 1 1/8" Border - T-bar Lay-in

Model MC6600-20-6 - 3/4" Border - T-bar Lay-in

Model MC6600-30-6 - 1/2" Border - T-bar Lay-in

Model MC6600-22-73 - 3/4" Border - Concealed Spline

Model MC6600-22-74 - 3/4" Border - Concealed Spline

Model MC6600-40-7 - 25/32" Border - Concealed Spline

Model MC6600-42-7 - 25/32" Border - Concealed Mounting

Model MC6600-40-8 - 25/32" Border - Drop Face

Model MC6600-40-9 - 25/32" Border - Donn Finline

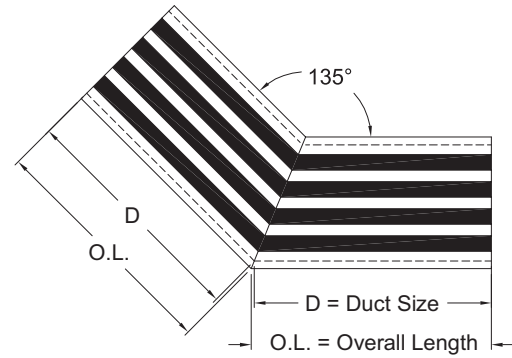

Number of Slots	Duct Size (All Models)	Mitered Corner Models (1/2", 3/4" or 1" Slot)				
		MC6600-11-1 MC6600-12-1 MC6600-10-6 MC6600-12-6	MC6600-20-6 MC6600-22-73 MC6600-22-74	MC6600-30-6	MC6600-40-7 MC6600-42-7 MC6600-40-8	MC6600-40-9
		O.L.	O.L.	O.L.	O.L.	O.L.
1 - 3	12	12-13/32	12-1/4	12-5/32	12-9/32	12-9/32
4 - 8	24	24-13-32	24-1/4	24-5/32	24-9/32	24-9-32

# LSD - Linear Slot Diffusers

8/2006

➔ Linear Slot for Spiral Pipe ➔ Aluminum ➔ Series 6600SP ➔ Supply  
 ➔ Series 6600SPR ➔ Return

## Product Details

- ✪ The series 6600SP is designed to integrate into exposed spiral duct systems
- ✪ Series 6600SP pattern controllers are fully adjustable and can be set from horizontal to vertical discharge
- ✪ The series 6600SP operates effectively from minimum to maximum flow making this diffuser an excellent selection for variable volume systems
- ✪ Series 6600SPR is designed for return applications. The unit is supplied without pattern controllers to reduce pressure and noise



### Model 6610SP Shown

Standard Finish: 20 White Border  
 with Black Pattern Controller

Linear Slot Diffusers

LSD

## Linear Slot for Spiral Pipe - Aluminum - Surface Mount - 1 1/8" - Series 6600SP/6600SPR

Model 6610SP-11-1 - Supply - Screw Mounted

Model 6610SPR-11-1 - Return - Screw Mounted

Model 6610SP-12-1 - Supply - Concealed Mounting Hardware

Model 6610SPR-12-1 - Return - Concealed Mounting Hardware

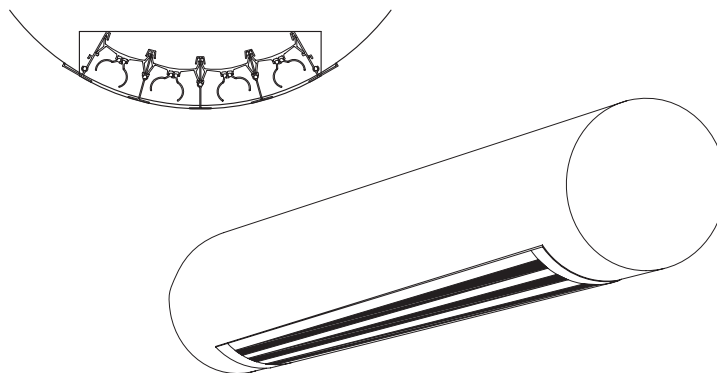

### 6610SP is available only in a 1" Slot Width

Pipe Diameter	Available Slots
10" Round	1, 2
12" Round	1, 2, 3
14" Round	1, 2, 3
16" Round	1, 2, 3, 4
18" Round	1, 2, 3, 4
20" Round	1, 2, 3, 4
24" Round	1, 2, 3, 4
30" Round	1, 2, 3, 4

## Notes for Models 66(50,75,10)-( [10-6,12-6,20-6,30-6], [11-1,12-1], [40-7,42-7], [40-8], [40-9], [22-73,22-74] )

1. Available Finishes	2. Construction Details
<p><b>Standard Finish:</b>                      20 White frame with black pattern controller</p> <p><b>Optional Finish (additional charge):</b>                      21 Clear anodized with black pattern controller                      28 Custom color</p>	<ul style="list-style-type: none"> <li>• Sizes available in only 1-4 slots</li> <li>• Slot widths 1"</li> <li>• Longest single section is 6 feet</li> </ul>

## Series 6600SP/6600SPR - Performance

### 6610 1" Slot - CFM Per Linear Foot

Slots	Static Pressure	Horizontal Vertical	0.008	0.030	0.047	0.068	0.092	0.120	0.152	0.188	0.227	0.270
			0.003	0.012	0.020	0.028	0.037	0.04	0.061	0.076	0.092	0.109
1		CFM/LF	10	20	25	30	35	40	45	50	55	60
		Horizontal Throw, ft	1-2-6	3-6-22	4-10-24	6-14-27	9-19-29	11-22-31	14-23-33	18-24-35	20-26-36	22-27-38
		Vertical Throw, ft	2	10	12	13	14	15	16	17	18	18
		Horizontal NC	<15	<15	<15	<15	19	22	24	26	28	30
		Vertical NC	<15	<15	<15	<15	<15	<15	<15	<15	16	18
2		CFM/LF	20	40	50	60	70	80	90	100	110	120
		Horizontal Throw, ft	1-3-10	5-10-29	7-16-35	10-22-38	14-26-41	19-29-44	22-33-46	25-35-49	27-36-51	29-38-54
		Vertical Throw, ft	4	14	17	18	20	21	23	24	25	26
		Horizontal NC	<15	<15	<15	<15	21	25	27	29	31	33
		Vertical NC	<15	<15	<15	<15	<15	<15	15	17	19	21
3		CFM/LF	30	60	75	90	105	120	135	150	165	180
		Horizontal Throw, ft	3-7-18	12-18-36	15-23-41	18-27-44	21-32-48	24-26-51	27-39-54	30-41-57	33-43-60	36-44-63
		Vertical Throw, ft	4	17	21	23	24	26	28	29	31	32
		Horizontal NC	<15	<15	<15	17	22	27	28	30	32	34
		Vertical NC	<15	<15	<15	<15	<15	15	16	18	20	22
4		CFM/LF	40	80	100	120	140	160	180	200	220	240
		Horizontal Throw, ft	4-10-24	16-24-42	20-30-47	24-36-51	28-39-55	32-42-59	36-44-63	38-47-66	40-49-70	42-51-73
		Vertical Throw, ft	5	20	24	26	28	30	32	34	35	37
		Horizontal NC	<15	<15	15	19	24	29	30	32	34	36
		Vertical NC	<15	<15	<15	<15	<15	17	18	20	22	24

See Page LSD-187 for Performance Notes



## Series 6600SP/6600SPR Performance

### 6610R 1" Slot Width

Number of Slots	Negative Ps Inches of Water	.02	.04	.06	.08	.10	.15
1	CFM/Ft.	35	50	60	70	80	95
Ak/Ft=.06	NC	-	25	31	36	40	45
2	CFM/Ft.	70	100	125	140	155	190
Ak/Ft=.11	NC	-	27	33	37	41	47
3	CFM/Ft.	105	150	185	210	235	285
Ak/Ft=.17	NC	-	29	35	39	43	49
4	CFM/Ft.	140	200	250	280	310	380
Ak/Ft=.23	NC	-	31	37	41	45	51

See Page LSD-187 for Performance Notes



## Series 6600SP/6600SPR - Performance Notes

### Performance Notes:

1. On units without BP/BPI plenums, pressure drop reported is across the diffuser element only. The field supply plenum pressure drop should be included when determining system fan requirements. A good approximation of the static pressure requirements can be calculated by adding the velocity pressure through the plenum inlet to the diffuser section pressure drop.
2. NC is based on a 4 ft section of diffuser. The following table should be used to calculate sound levels for lengths other than 4 ft.
3. To correct throws for lengths other than the 4 ft lengths used in determining catalog performance, throws should be adjusted per the following table:

NC Correction for Length			
Length (feet)	2	4	6
NC Correction	-2	+0	+2
Throw Correction Multiplier for Length			
Length (feet)	2	4	6
Throw Correction	.7	1.0	1.2

4. All pressures are in inches of water
5. Isothermal throws are given for terminal velocities of 150, 100 and 50 fpm, based upon 4 ft section
6. Vertical throw values are based on a 50 fpm terminal velocity
7. For Vertical supply, subtract one NC
8. For Returns minus pattern controllers, deduct 12 NC.
9. Throw values are based on a 1-way discharge from the slot. For 2-way discharges, throw is based upon the number and size of the slots throwing in each direction, with the total supply air flow split equally between all slots in the unit.
10. Data were collected in accordance to ASHRAE Standard 70-1991 "Method of Testing for Rating the Performance of Air Outlets and Inlets."



## Series 6600 SP - Specification

Air outlets shall be model 6600 (supply) or 6600SPR (return) linear slot diffusers manufactured by METALAIRE. Units shall be constructed of heavy gauge extruded aluminum. The units shall be the size and quantity as outline in the plans and specifications. Units shall be available with 1" slot widths.

For supply linear slot diffusers, the pattern controller shall be curved, aerodynamically shaped, capable of adjustment from the face of the diffuser. The pattern controller shall allow adjustment from vertical to horizontal patterns as well as damper the volume through the face of the diffuser. Pattern controllers shall be aluminum construction. Steel pattern controllers are not acceptable.

For return linear slot diffuser, the unit will be provided without pattern controllers to minimize pressure drop and noise.

Linear slot diffusers shall be available in one-piece sections up to 6ft. Units shall be available with one to four slots.

Supply units shall be furnished with the face white and the pattern controller black.

### Performance Specification

The manufacturer shall provide published performance data. Data shall be tested in accordance to ANSI/ASHRAE Standard 70-1991.

### Paint Specification

Process shall be anodic electrodeposition using an anodic acrylic paint. Units shall undergo pre-treatment including a pressurized spray stage using an alkaine cleaner and a de-ionize water rinse.

Film Properties shall meet or exceed the following standards:

Property	Test Method	Performance
Film thickness		.8-1.0 mils
Film Cure		320 F @ 20 min
Gloss – 60 deg.	ASTM D523-89	70-80%
Pencil Hardness	ASTM D3363-92A	HB-H
Crosshatch Adhesion	ASTM D3359-95	4B-5B
Direct Impact	ASTM D2794-93	100 in.lbs. Min
Reverse Impact	ASTM D2794-93	60 in.lbs. Min.
Salt Spray	ASTM B117-95	48-96 Hours
Humidity	ASTM D1735-92	500 Hours
Water Soak	ASTM D870-92	250 Hours

# LEADING THE INDUSTRY IN PRODUCT LITERATURE

With the choice of our Pre-Flite Catalog, Quick Select Catalog, InfoSource Catalog, InfoSource CD and our web site, [www.metalaire.com](http://www.metalaire.com), you pick the format for product information that best suits your air distribution design needs.

## Pre-Flite - Product Overview Catalog

The METALAIRE Pre-Flite catalog is a condensed reference guide containing concise listings of our entire product line including grilles, registers, diffusers, and air terminal units. This catalog can be used to help select the type of device, along with available border styles. The catalog includes photos of each model along with the features and model guide, a great tool when you are trying to select a device for your project.



## Quick Select Catalog - Air Distribution Selection Made Easy

The METALAIRE Quick Select Catalog is designed to save you time selecting air distribution equipment. This catalog is a compact version of our InfoSource Catalogs and includes drawings and performance for our most popular products. The Quick Select Catalog is broken into product types with each section beginning with a model summary that includes features and benefits of our products. To obtain product information not included in the Quick Select Catalog, simply go to our web site at [www.metalaire.com](http://www.metalaire.com).



## InfoSource Catalog Suite - Complete guide to Air Distribution Selection

The METALAIRE InfoSource Catalog suite is the leading product catalog in the industry. Included in these catalogs are the complete product listings, drawings, product features and benefits, product performance data, specifications, and model specifications. These catalogs are organized to make it quick and easy to find the information you are looking for.

### InfoSource Catalog Suite

- Ceiling Diffusers Catalog
- Grilles & Registers Catalog
- Air Terminal Unit Catalog
- Formations Catalog



## InfoSource CD

Our InfoSource CD has set the standard in the industry for air distribution product selection. This CD contains a complete library of all our catalogs and submittals along with our air terminal unit selection program.



## Web Site: [www.metalaire.com](http://www.metalaire.com)

METALAIRE leads the industry with a web site that contains all the product literature and performance data needed to design your air distribution system. Our web site includes all our submittals, catalogs, installation manuals, as well as as other valuable information to aid you in air distribution design.



## ➔ Boot Plenums ➔ Insulated/Non-Insulated ➔ Series BP ➔ Steel

### Product Details

- ✦ The series BP (non-insulated) and BPI (insulated) boot plenums are designed to connect the series 6600 linear slot diffusers to the ducted supply or return system
- ✦ Units provide an even distribution of air into the series 6600 diffuser to maximize induction and occupant comfort
- ✦ The series BPI boot plenum is fully insulated — including the end caps
- ✦ Units can be used for both ducted and plenum returns
- ✦ Factory tested and manufactured BP/BPI plenums are built to fit securely into the series 6600 of diffusers reducing installation cost and minimizing leakage
- ✦ Available with an optional quadrant locking damper
- ✦ Series BP & BPI are shipped separate from series 6600 linear slot diffusers and require field attachment

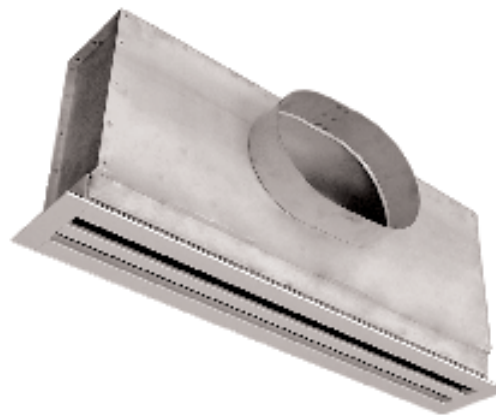

**Model BP Shown w/  
6600 Series Linear Slot Diffuser**  
(BP & BPI are shipped separate for field installation)

	Non Insulated				
	T-bar Lay-in	Surface Mount	Concealed Spline	Drop Face	Narrow Tee
Screw Mounted		BP-11-1 1 1/8" Border			
Concealed Mounting Hardware	BP-12-6 1 1/8" Border	BP-12-1 1 1/8" Border	BP-42-7 25/32" Border		
No Mounting Hardware	BP-10-6 1 1/8" Border		BP-40-7 25/32" Border	BP-40-8 25/32" Border	BP-40-9 25/32" Border
	BP-20-6 3/4" Border				
	BP-30-6 1/2" Border				

Concealed Spline/Plaster Mounting Frame	Concealed Wall Mounted Spline/Plaster Mounting Frame
BP-22-73 3/4" Border	BP-22-74 3/4" Border

	Insulated				
	T-bar Lay-in	Surface Mount	Concealed Spline	Drop Face	Narrow Tee
Screw Mounted		BPI-11-1 1 1/8" Border			
Concealed Mounting Hardware	BPI-12-6 1 1/8" Border	BPI-12-1 1 1/8" Border	BPI-42-7 25/32" Border		
No Mounting Hardware	BPI-10-6 1 1/8" Border		BPI-40-7 25/32" Border	BPI-40-8 25/32" Border	BPI-40-9 25/32" Border
	BPI-20-6 3/4" Border				
	BPI-30-6 1/2" Border				

Concealed Spline/Plaster Mounting Frame	Concealed Wall Mounted Spline/Plaster Mounting Frame
BPI-22-73 3/4" Border	BPI-22-74 3/4" Border

# LSD - Linear Slot Diffusers



## Non Insulated/Insulated Boot Plenums

### Steel - Hemmed Plenums

- Model BP (BPI)-12-1 - *Surface Mount - 1 1/8" Border*
- Model BP (BPI)-12-6 - *T-bar Lay-in - 1 1/8" Border*
- Model BP (BPI)-22-73 - *Concealed Spline - 3/4" Border*
- Model BP (BPI)-22-74 - *Concealed Spline - 3/4" Border*
- Model BP (BPI)-42-7 - *Concealed Spline - 25/32" Border*

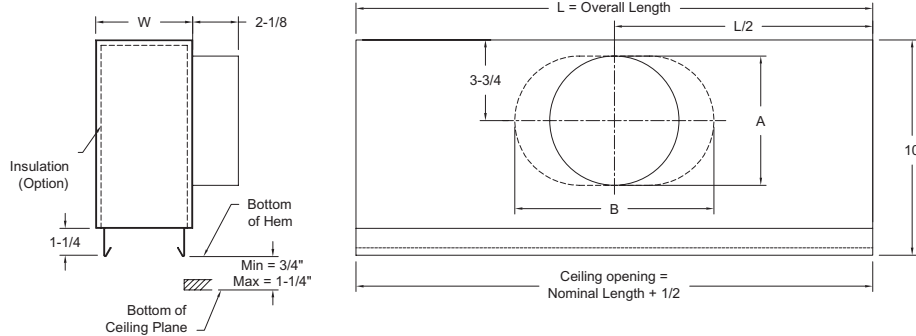

Available Nominal Lengths	24	36	48	60
---------------------------	----	----	----	----

Model 6650 (1/2" Slot Width)				Model 6675 (3/4" Slot Width)				Model 6610 (1" Slot Width)				Models	Overall Length (L)	Available Inlets	Round Dim. (A)	Oval Dim. (A x B)
Width (W)				Width (W)				Width (W)								
1 Slot	2 Slot	3 Slot	4 Slot	1 Slot	2 Slot	3 Slot	4 Slot	1 Slot	2 Slot	3 Slot	4 Slot	BP (BPI)-12-1	N.L. - 1/16	6	5 7/8	-
2 5/8	3 7/8	5 1/8	6 3/8	2 7/8	4 3/8	5 7/8	7 3/8	3 1/8	4 7/8	6 5/8	8 3/8	BP (BPI)-12-6	N.L. - 2 7/16	8	-	5 7/8 x 8 15/16
5 Slot	6 Slot	7 Slot	8 Slot	5 Slot	6 Slot	7 Slot	8 Slot	5 Slot	6 Slot	7 Slot	8 Slot	BP (BPI)-22-73	N.L. - 1 1/4	10	-	5 7/8 x 12 1/16
7 5/8	8 7/8	10 1/8	11 3/8	8 7/8	10 3/8	11 7/8	13 3/8	10 1/8	11 7/8	13 5/8	15 3/8	BP (BPI)-22-74	N.L. - 1 1/4	12	-	5 7/8 x 15 1/4
												BP (BPI)-42-7	N.L. - 9/16	14	-	5 7/8 x 18 7/16

## Non Insulated/Insulated Boot Plenums

### Steel - Straight Plenums

- Model BP (BPI)-10-6 - *T-bar Lay-in 1/8" Border*
- Model BP (BPI)-20-6 - *T-bar Lay-in 3/4" Border*
- Model BP (BPI)-30-6 - *T-bar Lay-in 1/2" Border*
- Model BP (BPI)-11-1 - *Surface Mount 1 1/8" Border*
- Model BP (BPI)-40-7 - *Concealed Spline - 25/32" Border*
- Model BP (BPI)-40-8 - *Drop Face - 25/32" Border*
- Model BP (BPI)-40-9 - *Donn Finline - 25/32" Border*

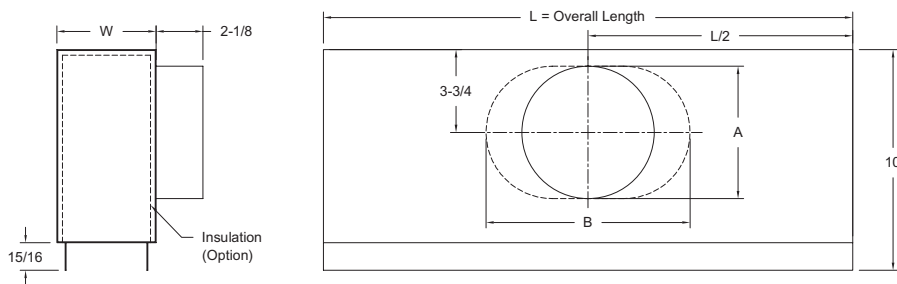

Available Nominal Lengths	24	36	48	60
---------------------------	----	----	----	----

Model 6650 (1/2" Slot Width)				Model 6675 (3/4" Slot Width)				Model 6610 (1" Slot Width)				Models	Overall Length (L)	Available Inlets	Round Dim. (A)	Oval Dim. (A x B)
Width (W)				Width (W)				Width (W)								
1 Slot	2 Slot	3 Slot	4 Slot	1 Slot	2 Slot	3 Slot	4 Slot	1 Slot	2 Slot	3 Slot	4 Slot	BP (BPI)-11-1	N.L. - 1/16	6	5 7/8	-
2 1/8	3 3/8	4 5/8	5 7/8	2 3/8	3 7/8	5 3/8	6 7/8	2 5/8	4 3/8	6 1/8	7 7/8	BP (BPI)-10-6	N.L. - 2 7/16	8	-	5 7/8 x 8 15/16
5 Slot	6 Slot	7 Slot	8 Slot	5 Slot	6 Slot	7 Slot	8 Slot	5 Slot	6 Slot	7 Slot	8 Slot	BP (BPI)-30-6	N.L. - 15/16	10	-	5 7/8 x 12 1/16
7 1/8	8 3/8	9 5/8	10 7/8	8 3/8	9 7/8	11 3/8	12 7/8	9 5/8	11 3/8	13 1/8	14 7/8	BP (BPI)-40-7	N.L. - 9/16	12	-	5 7/8 x 15 1/4
												BP (BPI)-40-8	N.L. - 9/16	14	-	5 7/8 x 18 7/16
												BP (BPI)-40-9	N.L. - 9/16			

# LSD - Linear Slot Diffusers

8/2006

## Series 6650 BP/BPI - Performance

### 6650 - 1 Slot Performance Data

6" Inlet 1 Slot	2' Length	CFM	15	30	45	60	75	90	105
		Static Pressure	0.010	0.038	0.086	0.153	0.240	0.345	0.470
		Horizontal Throw, ft	1-3-9	6-9-18	9-13-23	12-18-27	15-21-30	18-23-33	20-25-35
	4' Length	NC	<15	20	28	35	41	45	47
		CFM	30	60	90	120	150	180	210
		Static Pressure	0.016	0.063	0.142	0.252	0.394	0.567	0.772
8" Inlet 1 Slot	2' Length	Horizontal Throw, ft	2-4-7	5-7-15	7-11-21	10-15-24	12-18-27	15-21-30	17-23-32
		NC	<15	24	34	41	45	46	49
		CFM	20	35	50	65	80	95	110
	4' Length	Static Pressure	0.018	0.054	0.110	0.185	0.281	0.396	0.531
		Horizontal Throw, ft	3-6-12	7-10-20	10-15-24	13-19-28	16-22-31	19-24-34	21-26-36
		NC	<15	18	27	33	38	42	44
10" Inlet 1 Slot	2' Length	CFM	40	70	100	130	160	190	220
		Static Pressure	0.018	0.056	0.115	0.194	0.294	0.415	0.556
		Horizontal Throw, ft	3-5-10	6-9-17	8-12-22	11-16-25	13-20-28	16-22-31	18-23-33
	4' Length	NC	<15	24	33	39	43	45	45
		CFM	30	45	60	75	90	105	120
		Static Pressure	0.056	0.126	0.225	0.351	0.505	0.688	0.899
12" Inlet 1 Slot	2' Length	Horizontal Throw, ft	6-9-18	9-13-23	12-18-27	15-21-30	18-23-33	20-25-35	22-27-38
		NC	<15	22	29	34	39	42	43
		CFM	60	90	120	150	180	210	240
	4' Length	Static Pressure	0.036	0.082	0.146	0.227	0.328	0.446	0.582
		Horizontal Throw, ft	5-7-15	7-11-21	10-15-22	12-18-27	15-21-30	17-23-32	20-24-35
		NC	19	27	34	40	45	48	51
12" Inlet 1 Slot	2' Length	CFM	45	60	75	90	105	120	135
		Static Pressure	0.047	0.083	0.129	0.186	0.254	0.331	0.419
		Horizontal Throw, ft	9-13-23	12-18-27	15-21-30	18-23-33	20-25-35	22-27-38	23-28-40
	4' Length	NC	24	28	32	35	39	42	45
		CFM	90	120	150	180	210	240	270
		Static Pressure	0.098	0.175	0.273	0.393	0.535	0.699	0.884
12" Inlet 1 Slot	2' Length	Horizontal Throw, ft	7-11-21	10-15-24	12-18-27	15-21-30	17-23-32	20-24-35	21-26-37
		NC	23	30	36	41	45	48	51
		CFM	20	40	60	80	100	120	140

### 6650 - 2 Slot Performance Data

6" Inlet 2 Slot	2' Length	CFM	20	40	60	80	100	120	140
		Static Pressure	0.007	0.028	0.064	0.114	0.178	0.256	0.349
		Horizontal Throw, ft	1-2-8	4-8-17	8-12-25	11-17-31	14-21-35	17-25-38	19-29-41
	4' Length	NC	<15	15	25	32	38	43	46
		CFM	30	60	90	120	150	180	210
		Static Pressure	0.010	0.041	0.093	0.166	0.259	0.373	0.507
8" Inlet 2 Slot	2' Length	Horizontal Throw, ft	1-2-5	3-5-10	5-8-16	7-10-21	9-13-26	10-16-30	12-18-32
		NC	<15	<15	24	32	37	41	43
		CFM	25	45	65	85	105	125	145
	4' Length	Static Pressure	0.007	0.023	0.049	0.084	0.128	0.181	0.244
		Horizontal Throw, ft	1-3-10	5-9-19	9-14-27	12-18-32	15-22-35	17-26-39	20-29-42
		NC	<15	<15	23	29	35	39	43
10" Inlet 2 Slot	2' Length	CFM	50	90	130	170	210	250	290
		Static Pressure	0.014	0.045	0.094	0.161	0.245	0.348	0.468
		Horizontal Throw, ft	3-4-9	5-8-16	8-11-23	10-15-29	12-18-32	14-22-35	17-25-38
	4' Length	NC	<15	20	29	36	41	45	46
		CFM	35	55	75	95	115	135	155
		Static Pressure	0.013	0.032	0.059	0.095	0.139	0.191	0.252
12" Inlet 2 Slot	2' Length	Horizontal Throw, ft	3-6-15	7-11-23	10-16-30	13-20-34	16-24-37	19-28-40	21-30-43
		NC	<15	17	23	29	34	38	41
		CFM	70	110	150	190	230	270	310
	4' Length	Static Pressure	0.019	0.047	0.088	0.142	0.207	0.286	0.377
		Horizontal Throw, ft	4-6-12	6-10-19	9-13-26	11-16-31	13-20-34	16-23-37	18-27-39
		NC	<15	21	29	35	40	43	45
12" Inlet 2 Slot	2' Length	CFM	50	70	90	110	130	150	170
		Static Pressure	0.024	0.047	0.078	0.117	0.163	0.217	0.279
		Horizontal Throw, ft	6-10-21	10-15-29	12-19-33	15-23-36	18-27-39	21-30-42	24-32-45
	4' Length	NC	<15	<15	17	21	24	28	31
		CFM	100	140	180	220	260	300	340
		Static Pressure	0.027	0.053	0.087	0.130	0.181	0.241	0.310
12" Inlet 2 Slot	2' Length	Horizontal Throw, ft	6-9-17	8-12-24	10-16-30	13-19-33	15-23-36	17-26-39	20-29-41
		NC	16	23	29	34	38	41	43
		CFM	20	40	60	80	100	120	140

See Page LSD-199 for Performance Notes



## Series 6650 BP/BPI - Performance

### 6650 3 Slot Performance Data

6" Inlet 3 Slot	2' Length	CFM	25	50	75	100	125	150	175
		Static Pressure	0.008	0.033	0.073	0.130	0.203	0.293	0.398
		Horizontal Throw, ft	1-2-7	3-7-17	7-13-25	11-17-34	14-21-39	17-25-42	20-30-46
	4' Length	NC	<15	15	24	31	36	40	43
		CFM	40	75	115	150	190	225	265
		Static Pressure	0.015	0.054	0.127	0.216	0.347	0.486	0.674
8" Inlet 3 Slot	2' Length	Horizontal Throw, ft	1-2-6	4-5-11	5-8-16	7-11-21	9-13-27	11-16-32	12-19-36
		NC	<15	<15	23	29	36	40	44
		CFM	35	55	80	105	130	155	180
	4' Length	Static Pressure	0.009	0.022	0.046	0.079	0.122	0.173	0.233
		Horizontal Throw, ft	2-3-12	4-9-19	8-14-27	12-18-35	15-22-39	18-26-43	20-31-46
		NC	<15	<15	21	28	33	37	41
10" Inlet 3 Slot	2' Length	CFM	70	110	160	210	260	310	360
		Static Pressure	0.021	0.052	0.109	0.188	0.289	0.410	0.553
		Horizontal Throw, ft	3-5-10	5-8-16	8-11-23	10-15-30	12-18-36	15-22-39	17-25-42
	4' Length	NC	<15	18	27	34	39	44	47
		CFM	45	65	90	115	140	165	190
		Static Pressure	0.011	0.023	0.044	0.072	0.106	0.147	0.195
12" Inlet 3 Slot	2' Length	Horizontal Throw, ft	3-6-15	5-11-22	10-15-31	13-20-37	16-24-41	19-28-44	21-32-48
		NC	<15	<15	21	27	32	36	39
		CFM	90	130	180	230	280	330	380
	4' Length	Static Pressure	0.023	0.048	0.091	0.149	0.221	0.307	0.407
		Horizontal Throw, ft	4-6-13	6-9-18	8-13-25	11-16-33	13-20-36	16-23-39	18-27-42
		NC	<15	20	27	33	38	42	45
12" Inlet 3 Slot	2' Length	CFM	65	85	110	135	160	185	210
		Static Pressure	0.022	0.038	0.063	0.095	0.133	0.178	0.229
		Horizontal Throw, ft	5-11-22	9-14-29	12-19-36	15-23-40	18-27-44	21-31-47	24-35-50
	4' Length	NC	<15	16	20	23	26	29	32
		CFM	130	170	220	270	320	370	420
		Static Pressure	0.027	0.046	0.077	0.117	0.164	0.219	0.282
4' Length	Horizontal Throw, ft	6-9-18	8-12-24	10-16-31	13-19-37	15-23-40	17-26-43	20-30-46	
	NC	17	22	27	33	37	41	44	

### 6650 4 Slot Performance Data

6" Inlet 4 Slot	2' Length	CFM	40	65	90	115	140	165	190
		Static Pressure	0.018	0.047	0.090	0.147	0.218	0.302	0.401
		Horizontal Throw, ft	1-3-12	3-8-19	7-13-26	11-17-34	14-21-41	16-24-44	19-28-48
	4' Length	NC	<15	16	24	30	36	39	42
		CFM	60	100	135	175	210	250	285
		Static Pressure	0.031	0.087	0.159	0.267	0.385	0.546	0.709
8" Inlet 4 Slot	2' Length	Horizontal Throw, ft	1-3-7	4-6-12	6-8-17	7-11-21	9-13-26	10-15-31	12-17-35
		NC	<15	16	24	31	35	37	40
		CFM	50	80	110	140	170	200	230
	4' Length	Static Pressure	0.014	0.036	0.069	0.112	0.164	0.228	0.301
		Horizontal Throw, ft	2-5-15	5-12-24	10-16-32	14-21-41	17-25-45	20-29-49	23-34-53
		NC	<15	17	24	30	35	39	42
10" Inlet 4 Slot	2' Length	CFM	75	120	165	210	255	300	345
		Static Pressure	0.022	0.056	0.107	0.173	0.255	0.353	0.467
		Horizontal Throw, ft	2-5-9	5-7-15	7-10-20	9-13-26	10-16-31	12-18-37	14-21-42
	4' Length	NC	<15	16	23	29	34	38	40
		CFM	60	90	120	150	180	210	240
		Static Pressure	0.014	0.032	0.056	0.088	0.127	0.173	0.226
12" Inlet 4 Slot	2' Length	Horizontal Throw, ft	3-7-18	7-13-26	12-18-35	15-22-42	18-26-46	21-31-50	24-35-54
		NC	<15	17	23	29	33	37	41
		CFM	95	135	180	225	270	315	360
	4' Length	Static Pressure	0.021	0.043	0.077	0.120	0.174	0.236	0.308
		Horizontal Throw, ft	4-6-12	6-8-17	7-11-22	9-14-28	11-17-33	13-19-38	15-22-41
		NC	<15	16	23	28	33	36	39
12" Inlet 4 Slot	2' Length	CFM	80	120	160	200	240	280	320
		Static Pressure	0.018	0.041	0.073	0.114	0.164	0.223	0.292
		Horizontal Throw, ft	5-12-24	12-18-35	16-24-44	20-29-49	24-35-54	27-41-58	31-44-62
	4' Length	NC	<15	<15	20	24	28	32	35
		CFM	120	180	240	300	360	420	480
		Static Pressure	0.018	0.040	0.071	0.111	0.159	0.217	0.283
4' Length	Horizontal Throw, ft	5-7-15	7-11-22	10-15-29	12-18-37	15-22-42	17-26-46	20-29-49	
	NC	<15	19	25	31	35	39	42	

See Page LSD-199 for Performance Notes



# LSD - Linear Slot Diffusers

## Series 6675 BP/BPI - Performance

### 6675 1 Slot Performance Data

6" Inlet 1 Slot	2' Length	CFM	20	35	50	65	80	95	110
		Static Pressure	0.014	0.043	0.088	0.148	0.224	0.316	0.424
		Horizontal Throw, ft	1-3-10	4-8-17	8-12-24	10-16-28	13-19-31	15-23-34	18-26-36
	4' Length	NC	<15	18	26	32	37	41	45
		CFM	30	52.5	75	97.5	120	142.5	165
		Static Pressure	0.009	0.026	0.054	0.091	0.137	0.194	0.259
8" Inlet 1 Slot	2' Length	Horizontal Throw, ft	2-3-6	4-5-11	5-8-15	7-10-20	8-12-24	10-14-27	11-17-29
		NC	<15	18	25	30	36	40	44
		CFM	40	60	85	105	130	150	175
	4' Length	Static Pressure	0.014	0.032	0.065	0.099	0.152	0.202	0.275
		Horizontal Throw, ft	3-4-8	4-6-12	6-9-17	7-11-21	9-13-25	10-15-27	12-18-30
		NC	<15	17	24	29	34	38	42
10" Inlet 1 Slot	2' Length	CFM	35	45	55	65	75	85	95
		Static Pressure	0.085	0.140	0.210	0.293	0.390	0.501	0.625
		Horizontal Throw, ft	4-8-17	7-11-22	9-13-26	10-16-28	12-18-30	14-20-32	15-23-34
	4' Length	NC	<15	17	22	26	30	33	35
		CFM	55	70	85	100	115	130	145
		Static Pressure	0.028	0.045	0.066	0.092	0.122	0.155	0.193
12" Inlet 1 Slot	2' Length	Horizontal Throw, ft	4-6-11	5-7-14	6-9-17	7-10-20	8-12-23	9-13-25	10-15-27
		NC	<15	17	21	25	28	31	34
		CFM	65	85	110	135	160	185	210
	4' Length	Static Pressure	0.022	0.038	0.063	0.095	0.133	0.178	0.229
		Horizontal Throw, ft	5-11-22	9-14-29	12-19-36	15-23-40	18-27-44	21-31-47	24-35-50
		NC	<15	16	20	23	26	29	32
4' Length	CFM	130	170	220	270	320	370	420	
	Static Pressure	0.027	0.046	0.077	0.117	0.164	0.219	0.282	
	Horizontal Throw, ft	6-9-18	8-12-24	10-16-31	13-19-37	15-23-40	17-26-43	20-30-46	
4' Length	NC	17	22	27	33	37	41	44	

### 6675 2 Slot Performance Data

6" Inlet 2 Slot	2' Length	CFM	30	55	80	105	130	155	180
		Static Pressure	0.009	0.029	0.061	0.105	0.161	0.228	0.308
		Horizontal Throw, ft	1-3-10	4-9-19	8-14-27	12-18-35	15-22-39	18-26-43	20-31-46
	4' Length	NC	<15	18	27	33	39	42	44
		CFM	45	85	120	160	195	235	270
		Static Pressure	0.009	0.033	0.065	0.116	0.172	0.250	0.330
8" Inlet 2 Slot	2' Length	Horizontal Throw, ft	1-3-6	4-6-12	6-8-17	8-11-23	9-14-28	11-17-33	13-19-37
		NC	<15	18	25	33	37	41	43
		CFM	45	65	85	105	125	145	165
	4' Length	Static Pressure	0.007	0.023	0.049	0.084	0.128	0.181	0.244
		Horizontal Throw, ft	1-3-10	5-9-19	9-14-27	12-18-32	15-22-35	17-26-39	20-29-42
		NC	<15	<15	23	29	35	39	43
10" Inlet 2 Slot	2' Length	CFM	70	100	130	160	190	220	250
		Static Pressure	0.014	0.028	0.047	0.071	0.100	0.135	0.174
		Horizontal Throw, ft	3-5-10	5-7-14	6-9-18	8-11-23	9-13-27	10-16-31	12-18-35
	4' Length	NC	<15	17	23	28	33	37	39
		CFM	50	70	90	110	130	150	170
		Static Pressure	0.023	0.045	0.074	0.111	0.155	0.207	0.265
12" Inlet 2 Slot	2' Length	Horizontal Throw, ft	3-7-17	6-12-24	10-15-31	12-19-36	15-22-39	17-25-42	19-29-45
		NC	<15	17	22	27	32	35	38
		CFM	75	105	135	165	195	225	255
	4' Length	Static Pressure	0.025	0.050	0.082	0.123	0.171	0.228	0.293
		Horizontal Throw, ft	4-5-11	5-7-15	6-10-19	8-12-23	9-14-28	11-16-32	12-18-36
		NC	<15	16	21	26	30	34	37
12" Inlet 2 Slot	2' Length	CFM	73	95	120	145	170	195	220
		Static Pressure	0.021	0.036	0.058	0.084	0.116	0.152	0.194
		Horizontal Throw, ft	7-12-25	11-16-32	14-20-38	16-25-42	19-29-45	22-33-48	25-36-51
	4' Length	NC	<15	18	21	25	28	31	34
		CFM	110	145	180	220	255	295	330
		Static Pressure	0.025	0.044	0.068	0.102	0.137	0.183	0.229
4' Length	Horizontal Throw, ft	5-8-16	7-10-21	8-13-25	10-16-31	12-18-36	14-21-38	16-23-41	
	NC	<15	20	24	29	33	36	39	

See Page LSD-199 for Performance Notes

# LSD - Linear Slot Diffusers

## Series 6675 BP/BPI - Performance

### 6675 3 Slot Performance Data

6" Inlet 3 Slot	2' Length	CFM	45	70	95	120	145	170	195
		Static Pressure	0.012	0.029	0.053	0.084	0.122	0.168	0.221
		Horizontal Throw, ft	1-3-12	3-8-19	6-13-26	10-17-33	13-20-40	16-24-45	18-27-48
	4' Length	NC	<15	17	24	30	35	39	41
		CFM	70	105	145	180	220	255	295
		Static Pressure	0.017	0.037	0.071	0.110	0.165	0.221	0.296
8" Inlet 3 Slot	2' Length	Horizontal Throw, ft	2-4-8	4-6-12	6-8-17	7-10-21	8-13-25	10-15-29	11-17-34
		NC	<15	17	24	29	34	38	41
		CFM	55	85	115	145	175	205	235
	4' Length	Static Pressure	0.012	0.029	0.054	0.082	0.124	0.171	0.224
		Horizontal Throw, ft	2-5-15	5-11-24	9-16-32	13-20-40	16-24-46	19-28-50	22-33-53
		NC	<15	18	25	30	35	39	42
10" Inlet 3 Slot	2' Length	CFM	85	130	175	220	265	310	355
		Static Pressure	0.013	0.031	0.057	0.090	0.130	0.178	0.233
		Horizontal Throw, ft	2-5-10	5-8-15	7-10-20	8-13-25	10-15-31	12-18-36	14-20-41
	4' Length	NC	<15	18	24	30	34	39	42
		CFM	65	100	130	160	190	220	250
		Static Pressure	0.015	0.037	0.062	0.094	0.132	0.177	0.229
12" Inlet 3 Slot	2' Length	Horizontal Throw, ft	3-7-18	7-14-28	12-18-36	15-22-44	18-26-48	20-30-51	23-35-55
		NC	<15	19	25	30	34	38	41
		CFM	100	150	195	240	285	330	375
	4' Length	Static Pressure	0.018	0.041	0.070	0.105	0.149	0.199	0.257
		Horizontal Throw, ft	3-6-12	6-9-17	8-11-23	9-14-28	11-16-33	13-19-38	14-22-42
		NC	<15	18	24	29	34	37	40
12" Inlet 3 Slot	2' Length	CFM	85	120	155	190	225	260	295
		Static Pressure	0.022	0.043	0.072	0.108	0.152	0.203	0.261
		Horizontal Throw, ft	5-11-24	10-17-33	14-21-43	18-26-48	21-31-2	24-36-56	27-41-59
	4' Length	NC	<15	<15	18	22	26	30	33
		CFM	130	180	235	285	340	390	445
		Static Pressure	0.016	0.031	0.053	0.078	0.111	0.146	0.190
12" Inlet 3 Slot	2' Length	Horizontal Throw, ft	5-8-15	7-10-21	9-14-27	11-16-33	13-20-39	15-23-44	17-26-47
		NC	<15	18	24	29	33	37	39
		CFM	100	140	180	220	260	300	340
	4' Length	Static Pressure	0.007	0.014	0.023	0.034	0.047	0.063	0.081
		Horizontal Throw, ft	4-10-24	9-17-34	14-22-43	18-26-51	21-31-56	24-36-60	27-41-64
		NC	<15	16	20	23	26	29	32
12" Inlet 3 Slot	2' Length	CFM	150	210	270	330	390	450	510
		Static Pressure	0.014	0.028	0.046	0.069	0.096	0.128	0.164
		Horizontal Throw, ft	5-8-15	7-11-21	9-14-27	11-17-33	13-20-39	15-23-45	17-26-50
	4' Length	NC	<15	19	24	28	32	36	39
		CFM	80	110	140	170	200	230	260
		Static Pressure	0.014	0.027	0.044	0.065	0.090	0.119	0.152
10" Inlet 4 Slot	2' Length	Horizontal Throw, ft	3-6-19	5-12-26	8-1-34	13-20-41	16-24-48	18-28-53	21-31-56
		NC	<15	17	23	27	32	35	38
		CFM	125	165	210	255	300	345	390
	4' Length	Static Pressure	0.017	0.030	0.049	0.072	0.099	0.131	0.167
		Horizontal Throw, ft	3-6-13	6-8-17	7-11-21	9-13-26	10-15-20	12-17-35	13-20-39
		NC	<15	16	22	26	30	34	37
12" Inlet 4 Slot	2' Length	CFM	100	140	180	220	260	300	340
		Static Pressure	0.007	0.014	0.023	0.034	0.047	0.063	0.081
		Horizontal Throw, ft	4-10-24	9-17-34	14-22-43	18-26-51	21-31-56	24-36-60	27-41-64
	4' Length	NC	<15	16	20	23	26	29	32
		CFM	150	210	270	330	390	450	510
		Static Pressure	0.014	0.028	0.046	0.069	0.096	0.128	0.164
12" Inlet 4 Slot	2' Length	Horizontal Throw, ft	5-8-15	7-11-21	9-14-27	11-17-33	13-20-39	15-23-45	17-26-50
		NC	<15	19	24	28	32	36	39
		CFM	100	140	180	220	260	300	340
	4' Length	Static Pressure	0.007	0.014	0.023	0.034	0.047	0.063	0.081
		Horizontal Throw, ft	4-10-24	9-17-34	14-22-43	18-26-51	21-31-56	24-36-60	27-41-64
		NC	<15	16	20	23	26	29	32

### 6675 4 Slot Performance Data

6" Inlet 4 Slot	2' Length	CFM	50	80	110	140	170	200	230
		Static Pressure	0.011	0.029	0.055	0.089	0.131	0.181	0.239
		Horizontal Throw, ft	1-3-10	3-6-19	5-12-26	9-17-34	13-20-41	16-24-48	18-28-53
	4' Length	NC	<15	16	23	30	35	39	43
		CFM	75	120	165	210	255	300	345
		Static Pressure	0.016	0.042	0.079	0.129	0.190	0.263	0.348
8" Inlet 4 Slot	2' Length	Horizontal Throw, ft	1-3-8	3-6-12	6-8-17	7-11-21	9-13-26	10-15-30	12-17-35
		NC	<15	16	23	29	34	37	39
		CFM	70	100	130	160	190	220	250
	4' Length	Static Pressure	0.016	0.042	0.079	0.129	0.190	0.263	0.348
		Horizontal Throw, ft	2-5-11	5-8-15	7-10-20	8-12-24	10-14-29	11-17-33	13-19-38
		NC	<15	17	23	28	32	36	39
10" Inlet 4 Slot	2' Length	CFM	80	110	140	170	200	230	260
		Static Pressure	0.014	0.027	0.044	0.065	0.090	0.119	0.152
		Horizontal Throw, ft	3-6-19	5-12-26	8-1-34	13-20-41	16-24-48	18-28-53	21-31-56
	4' Length	NC	<15	17	23	27	32	35	38
		CFM	125	165	210	255	300	345	390
		Static Pressure	0.017	0.030	0.049	0.072	0.099	0.131	0.167
12" Inlet 4 Slot	2' Length	Horizontal Throw, ft	3-6-13	6-8-17	7-11-21	9-13-26	10-15-20	12-17-35	13-20-39
		NC	<15	16	22	26	30	34	37
		CFM	100	140	180	220	260	300	340
	4' Length	Static Pressure	0.007	0.014	0.023	0.034	0.047	0.063	0.081
		Horizontal Throw, ft	4-10-24	9-17-34	14-22-43	18-26-51	21-31-56	24-36-60	27-41-64
		NC	<15	16	20	23	26	29	32
12" Inlet 4 Slot	2' Length	CFM	150	210	270	330	390	450	510
		Static Pressure	0.014	0.028	0.046	0.069	0.096	0.128	0.164
		Horizontal Throw, ft	5-8-15	7-11-21	9-14-27	11-17-33	13-20-39	15-23-45	17-26-50
	4' Length	NC	<15	19	24	28	32	36	39
		CFM	100	140	180	220	260	300	340
		Static Pressure	0.007	0.014	0.023	0.034	0.047	0.063	0.081
12" Inlet 4 Slot	2' Length	Horizontal Throw, ft	4-10-24	9-17-34	14-22-43	18-26-51	21-31-56	24-36-60	27-41-64
		NC	<15	16	20	23	26	29	32
		CFM	150	210	270	330	390	450	510
	4' Length	Static Pressure	0.014	0.028	0.046	0.069	0.096	0.128	0.164
		Horizontal Throw, ft	5-8-15	7-11-21	9-14-27	11-17-33	13-20-39	15-23-45	17-26-50
		NC	<15	19	24	28	32	36	39

See Page LSD-199 for Performance Notes

# LSD - Linear Slot Diffusers

## Series 6610 BP/BPI - Performance

### 6610 1 Slot Performance Data

6" Inlet 1 Slot	2' Length	CFM	30	45	60	75	90	105	120
		Static Pressure	0.013	0.029	0.052	0.082	0.117	0.160	0.209
		Horizontal Throw, ft	2-5-12	5-9-19	8-12-25	10-16-30	12-19-33	15-22-35	17-25-38
	4' Length	NC	16	23	30	35	40	44	46
		CFM	45	70	90	115	135	160	180
		Static Pressure	0.012	0.029	0.048	0.078	0.107	0.151	0.191
8" Inlet 1 Slot	2' Length	Horizontal Throw, ft	2-4-8	4-6-12	5-8-16	7-10-20	8-12-23	9-14-28	10-16-30
		NC	16	23	29	34	39	43	46
		CFM	40	50	65	80	95	110	125
	4' Length	Static Pressure	0.032	0.051	0.085	0.129	0.182	0.244	0.316
		Horizontal Throw, ft	4-8-17	6-10-21	9-14-27	11-17-31	13-20-34	15-23-36	17-26-39
		NC	17	22	28	33	38	40	42
10" Inlet 1 Slot	2' Length	CFM	60	75	100	120	145	165	190
		Static Pressure	0.017	0.026	0.047	0.068	0.099	0.128	0.170
		Horizontal Throw, ft	3-5-10	4-6-13	6-9-17	7-10-21	8-13-25	10-14-29	11-16-31
	4' Length	NC	17	21	28	32	37	40	43
		CFM	40	55	70	85	100	115	130
		Static Pressure	0.044	0.083	0.134	0.197	0.273	0.361	0.461
12" Inlet 1 Slot	2' Length	Horizontal Throw, ft	4-8-17	7-11-23	10-15-29	12-18-32	14-21-35	16-24-37	18-27-39
		NC	16	24	30	35	38	39	39
		CFM	60	85	105	130	150	175	195
	4' Length	Static Pressure	0.016	0.033	0.050	0.076	0.102	0.138	0.172
		Horizontal Throw, ft	3-5-10	5-7-15	6-9-18	8-11-23	9-13-26	10-15-30	11-17-31
		NC	<15	21	26	31	35	39	41
12" Inlet 1 Slot	2' Length	CFM	48	65	80	95	110	125	140
		Static Pressure	0.018	0.033	0.050	0.071	0.095	0.123	0.154
		Horizontal Throw, ft	5-10-20	9-14-27	11-17-31	13-20-34	15-23-36	17-26-39	19-29-41
	4' Length	NC	<15	<15	19	23	26	29	32
		CFM	70	100	120	145	165	190	210
		Static Pressure	0.029	0.058	0.084	0.123	0.159	0.211	0.258
		Horizontal Throw, ft	4-6-12	6-9-17	7-10-21	8-13-25	10-14-29	11-16-31	12-18-32
		NC	<15	21	25	30	33	35	37

### 6610 2 Slot Performance Data

6" Inlet 2 Slot	2' Length	CFM	30	55	80	105	130	155	180
		Static Pressure	0.006	0.020	0.042	0.072	0.110	0.156	0.211
		Horizontal Throw, ft	1-2-7	2-6-16	5-12-24	9-15-31	13-19-38	15-23-43	18-26-46
	4' Length	NC	<15	18	27	33	39	42	44
		CFM	45	85	120	160	195	235	270
		Static Pressure	0.009	0.031	0.061	0.109	0.162	0.235	0.310
8" Inlet 2 Slot	2' Length	Horizontal Throw, ft	1-2-6	3-5-10	5-7-15	7-10-20	8-12-24	10-14-29	11-17-33
		NC	<15	18	25	33	37	41	43
		CFM	45	65	85	105	125	145	165
	4' Length	Static Pressure	0.017	0.035	0.059	0.090	0.128	0.172	0.223
		Horizontal Throw, ft	2-4-13	3-8-19	6-12-25	9-15-31	12-18-37	14-21-42	16-24-44
		NC	<15	18	24	29	33	37	40
10" Inlet 2 Slot	2' Length	CFM	70	100	130	160	190	220	250
		Static Pressure	0.014	0.028	0.047	0.071	0.100	0.135	0.174
		Horizontal Throw, ft	2-4-9	4-6-12	5-8-16	7-10-20	8-12-23	9-13-27	10-15-31
	4' Length	NC	<15	17	23	28	33	37	39
		CFM	50	70	90	110	130	150	170
		Static Pressure	0.023	0.045	0.074	0.111	0.155	0.207	0.265
12" Inlet 2 Slot	2' Length	Horizontal Throw, ft	2-5-15	4-9-21	7-13-26	10-16-32	13-19-38	15-22-42	17-25-45
		NC	<15	17	22	27	32	35	38
		CFM	75	105	135	165	195	225	255
	4' Length	Static Pressure	0.012	0.024	0.039	0.059	0.082	0.109	0.140
		Horizontal Throw, ft	2-5-9	4-6-13	6-8-17	7-10-20	8-12-24	9-14-28	10-16-31
		NC	<15	16	21	26	30	34	37
12" Inlet 2 Slot	2' Length	CFM	60	90	120	150	180	210	240
		Static Pressure	0.014	0.032	0.058	0.090	0.130	0.176	0.230
		Horizontal Throw, ft	3-7-18	7-13-26	12-18-35	15-22-42	18-26-46	21-31-50	24-35-54
	4' Length	NC	<15	17	21	26	29	33	36
		CFM	90	135	180	225	270	315	360
		Static Pressure	0.017	0.038	0.068	0.106	0.153	0.208	0.272
		Horizontal Throw, ft	3-6-11	6-8-17	7-11-22	9-14-28	11-17-33	13-19-39	15-22-42
		NC	<15	18	24	30	34	38	41

See Page LSD-199 for Performance Notes

# LSD - Linear Slot Diffusers

## Series 6610 BP/BPI - Performance

### 6610 3 Slot Performance Data

6" Inlet 3 Slot	2' Length	CFM	40	65	90	115	140	165	190
		Static Pressure	0.007	0.019	0.036	0.058	0.087	0.120	0.160
		Horizontal Throw, ft	1-2-6	2-4-16	4-8-22	6-13-28	9-17-34	12-20-40	15-23-46
	4' Length	NC	<15	16	23	29	34	38	41
		CFM	60	100	135	175	210	250	285
		Static Pressure	0.011	0.030	0.055	0.093	0.134	0.190	0.247
8" Inlet 3 Slot	2' Length	Horizontal Throw, ft	1-2-6	2-5-10	4-7-14	6-9-18	7-11-21	8-13-25	10-14-29
		NC	<15	16	22	28	33	37	40
		CFM	50	80	110	140	170	200	230
	4' Length	Static Pressure	0.010	0.026	0.049	0.080	0.117	0.162	0.215
		Horizontal Throw, ft	1-3-10	3-6-19	5-12-26	9-17-34	13-20-41	16-24-48	18-28-53
		NC	<15	17	24	29	34	38	42
10" Inlet 3 Slot	2' Length	CFM	75	120	165	210	255	300	345
		Static Pressure	0.008	0.022	0.041	0.066	0.098	0.135	0.179
		Horizontal Throw, ft	1-3-8	3-6-12	6-8-17	7-11-21	9-13-26	10-15-30	12-17-35
	4' Length	NC	<15	17	23	28	33	38	41
		CFM	60	110	140	170	200	230	260
		Static Pressure	0.008	0.028	0.045	0.066	0.092	0.122	0.155
12" Inlet 3 Slot	2' Length	Horizontal Throw, ft	2-4-14	5-12-26	9-17-34	13-20-41	16-24-48	18-28-53	21-31-56
		NC	<15	21	27	32	36	39	42
		CFM	90	165	210	255	300	345	390
	4' Length	Static Pressure	0.008	0.026	0.042	0.062	0.086	0.113	0.145
		Horizontal Throw, ft	2-4-9	6-8-17	7-11-21	9-13-26	10-15-30	12-17-35	13-20-39
		NC	<15	20	26	31	35	38	40
12" Inlet 3 Slot	2' Length	CFM	80	120	160	200	240	280	320
		Static Pressure	0.010	0.022	0.038	0.060	0.086	0.118	0.154
		Horizontal Throw, ft	3-6-19	6-14-29	11-19-38	16-24-48	19-29-54	22-34-58	26-38-62
	4' Length	NC	<15	<15	19	23	28	31	35
		CFM	120	180	240	300	360	420	480
		Static Pressure	0.009	0.021	0.038	0.059	0.084	0.115	0.150
12" Inlet 3 Slot	2' Length	Horizontal Throw, ft	3-6-12	6-9-18	8-12-24	10-15-30	12-18-36	14-21-42	16-24-48
		NC	<15	18	25	30	35	38	41
		CFM	80	120	160	200	240	280	320

### 6610 4 Slot Performance Data

6" Inlet 4 Slot	2' Length	CFM	50	80	110	140	170	200	230
		Static Pressure	0.009	0.022	0.042	0.069	0.101	0.140	0.185
		Horizontal Throw, ft	1-2-6	2-4-17	3-8-23	6-13-29	8-18-35	12-21-42	15-24-48
	4' Length	NC	<15	16	23	30	35	39	43
		CFM	75	120	165	210	255	300	345
		Static Pressure	0.012	0.032	0.060	0.098	0.144	0.200	0.264
8" Inlet 4 Slot	2' Length	Horizontal Throw, ft	1-2-6	2-5-10	4-7-14	6-9-18	7-11-22	9-13-26	10-15-30
		NC	<15	16	23	29	34	37	39
		CFM	70	100	130	160	190	220	250
	4' Length	Static Pressure	0.017	0.035	0.059	0.090	0.126	0.169	0.219
		Horizontal Throw, ft	1-3-13	3-6-21	5-11-27	7-17-33	10-20-39	14-23-46	17-26-52
		NC	<15	18	24	29	33	37	39
10" Inlet 4 Slot	2' Length	CFM	105	150	195	240	285	330	375
		Static Pressure	0.013	0.027	0.045	0.068	0.096	0.129	0.166
		Horizontal Throw, ft	2-4-9	3-6-13	5-8-17	7-10-21	8-12-25	10-14-29	11-16-32
	4' Length	NC	<15	19	26	32	36	40	42
		CFM	80	120	160	200	240	280	320
		Static Pressure	0.010	0.022	0.038	0.060	0.086	0.118	0.154
12" Inlet 4 Slot	2' Length	Horizontal Throw, ft	2-4-17	4-9-25	7-17-33	12-21-42	17-25-50	19-29-58	22-33-62
		NC	<15	19	26	32	36	40	42
		CFM	125	180	240	300	360	420	480
	4' Length	Static Pressure	0.012	0.025	0.044	0.069	0.100	0.136	0.178
		Horizontal Throw, ft	2-5-11	5-8-16	7-10-21	9-13-26	10-16-31	12-18-36	14-21-42
		NC	<15	18	25	30	35	39	42
12" Inlet 4 Slot	2' Length	CFM	90	140	190	240	290	340	390
		Static Pressure	0.007	0.017	0.031	0.050	0.073	0.101	0.132
		Horizontal Throw, ft	2-5-19	6-13-29	10-20-39	17-25-50	20-30-59	24-35-64	27-41-68
	4' Length	NC	<15	16	21	25	28	32	35
		CFM	135	210	285	360	435	510	585
		Static Pressure	0.008	0.020	0.038	0.060	0.088	0.120	0.158
12" Inlet 4 Slot	2' Length	Horizontal Throw, ft	3-6-12	6-9-18	8-12-25	10-16-31	13-19-38	15-22-44	17-25-51
		NC	<15	19	25	30	35	39	42
		CFM	90	140	190	240	290	340	390

See Page LSD-199 for Performance Notes

## Series BP/BPI - Return Air Performance

### Return Air Performance 1/2" Slots (Duct Connected)

Number of Slots	Negative Ps Inches of Water	.02	.04	.06	.08	.10	.15
1	CFM/Ft.	15	20	25	30	35	40
Ak/Ft=.03	NC	--	20	27	32	37	41
2	CFM/Ft.	35	50	60	70	80	95
Ak/Ft=.06	NC	--	22	27	32	37	41
3	CFM/Ft.	55	80	95	110	125	150
Ak/Ft=.09	NC	--	23	28	33	37	42
4	CFM/Ft.	70	100	120	140	155	190
Ak/Ft=.12	NC	--	24	30	34	37	44
5	CFM/Ft.	90	135	155	180	200	245
Ak/Ft=.15	NC	--	25	30	34	37	44
6	CFM/Ft.	110	155	195	220	245	300
Ak/Ft=.18	NC	--	26	33	37	40	96
7	CFM/Ft.	130	185	225	260	290	355
Ak/Ft=.21	NC	--	27	33	37	41	47
8	CFM/Ft.	140	200	245	280	310	385
Ak/Ft=.24	NC	--	28	34	38	42	48

### Return Air Performance 3/4" Slots (Duct Connected)

Number of Slots	Negative Ps Inches of Water	.02	.04	.06	.08	.10	.15
1	CFM/Ft.	25	35	45	50	55	70
Ak/Ft=.02	NC	--	21	29	32	35	42
2	CFM/Ft.	55	80	90	100	110	135
Ak/Ft=.08	NC	--	25	29	32	35	42
3	CFM/Ft.	90	115	140	160	180	220
Ak/Ft=.12	NC	--	26	32	36	40	46
4	CFM/Ft.	100	140	175	200	225	275
Ak/Ft=.12	NC	--	27	34	38	41	47
5	CFM/Ft.	140	185	225	260	290	360
Ak/Ft=.16	NC	--	28	34	38	42	48
6	CFM/Ft.	160	225	275	320	360	440
Ak/Ft=.20	NC	--	29	35	40	43	49
7	CFM/Ft.	175	250	305	350	395	480
Ak/Ft=.24	NC	--	30	36	40	44	50
8	CFM/Ft.	200	285	350	400	450	545
Ak/Ft=.32	NC	--	31	37	41	45	51

### 6610R 1" Slot Width

Number of Slots	Negative Ps Inches of Water	.02	.04	.06	.08	.10	.15
1	CFM/Ft.	35	50	60	70	80	95
Ak/Ft=.06	NC	--	25	31	36	40	45
2	CFM/Ft.	70	100	125	140	155	190
Ak/Ft=.11	NC	--	27	33	37	41	47
3	CFM/Ft.	105	150	185	210	235	285
Ak/Ft=.17	NC	--	29	35	39	43	49
4	CFM/Ft.	140	200	250	280	310	380
Ak/Ft=.23	NC	--	31	37	41	45	51
5	CFM/Ft.	175	250	300	350	390	475
Ak/Ft=.28	NC	--	32	38	42	46	52
6	CFM/Ft.	210	300	375	420	465	570
Ak/Ft=.33	NC	--	33	40	43	47	53
7	CFM/Ft.	245	350	425	490	545	665
Ak/Ft=.39	NC	--	34	41	44	47	54
8	CFM/Ft.	280	400	475	560	620	760
Ak/Ft=.44	NC	--	35	42	45	48	55

See Page LSD-199 for Performance Notes

## Series BP - Performance Notes

### Performance Notes:

- On units without BP/BPI plenums, pressure drop reported is across the diffuser element only. The field supply plenum pressure drop should be included when determining system fan requirements. A good approximation of the static pressure requirements can be calculated by adding the velocity pressure through the plenum inlet to the diffuser section pressure drop.
- NC is based on a 4ft section of diffuser. The following table should be used to calculate sound levels for lengths other than 4 ft.
- To correct throws for lengths other than the 4 ft lengths used in determining catalog performance, throws should be adjusted per the following table:

NC Correction for Length					
Length (feet)	2	4	6	8	10
NC Correction	-2	+0	+2	+3	+5
Throw Correction Multiplier for Length					
Length (feet)	2	4	8	10	12
Throw Correction	.7	1.0	1.5	1.7	1.8

- All pressures are in inches of water
- Isothermal throws are given for terminal velocities of 150, 100 and 50 fpm, based upon 4 ft section
- Vertical throw values are based on a 50 fpm terminal velocity
- For Vertical supply, subtract one NC
- For Returns minus pattern controllers, deduct 12 NC.
- Throw values are based on a 1-way discharge from the slot. For 2-way discharges, throw is based upon the number and size of the slots throwing in each direction, with the total supply air flow split equally between all slots in the unit.
- Data were collected in accordance to ASHRAE Standard 70-1991 "Method of Testing for Rating the Performance of Air Outlets and Inlets."

## Series BP - Specification

Model BP – Non Insulated

Model BPI - Insulated

Boot plenums for model 6600 (supply) or 6600R (return) linear slot diffusers shall be provided by the manufacturer (Optional: manufactured by METALAIRE). The units shall be the size and quantity as outline in the plans and specifications. Units shall be constructed of coated steel. Optional: Units shall include 1/2 internal fiberglass insulation. Insulation must be applied to the end caps.

## ➔ Linear Louver Diffuser ➔ Model L-5000 ➔ Aluminum

### Product Details

- ✦ The series L-5000 is a fixed pattern, high induction architectural linear slot diffuser. This diffuser is constructed from heavy aluminum extrusions and is available with either 1-way or 2-way opposite air discharge patterns
- ✦ Also available is an optional plenum that allows the 2-way opposite unit to become a supply/return diffuser.
- ✦ T-bar Lay-in units available in 18", 24", 30", 36" or 42" and in surface mounting applications up to 48"
- ✦ 1-way units available in 3", 6", 9", 12" and 15" widths
- ✦ 2-way opposite units available in 6" and 12" widths
- ✦ The louvered face is secured with spring clips making removal easy for installation
- ✦ The series L-5000 is an excellent choice for VAV applications
- ✦ L-5000 surface mount diffuser available



**Model L-5000 Shown**

Standard Finish: 01 White

Linear Slot Diffusers

LSD

### Surface Mount

*Dimensions are in inches*

#### Series L-5000

Model L-5000-1 - *Dimensions same as above (with screw holes)*

The L-5000 can be used for combination Supply/Return applications.  
*Unit shown above with optional boot plenum.*

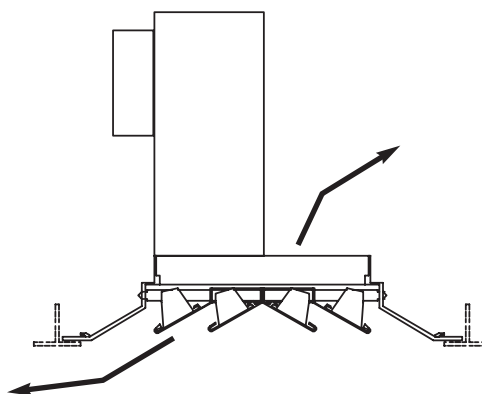
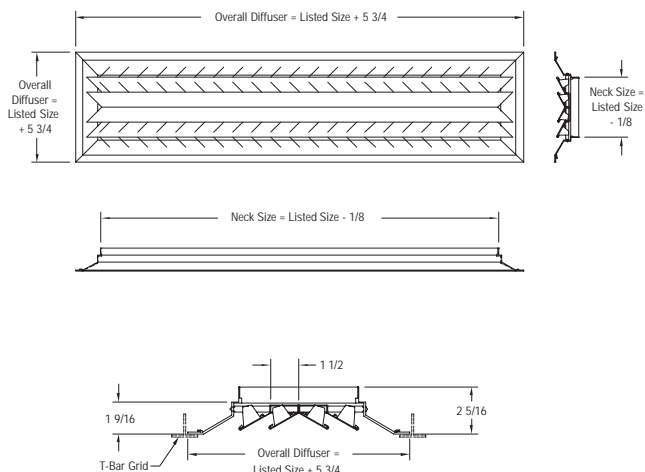

## Model L-5000 - Performance

Size in inches	Neck Velocity (VN) fpm	400	450	500	550	600	650	700
	Total Pressure	.057	.072	0.94	.110	.130	.168	.180
42 x 3 An .875	CFM ea. side	350	394	480	481	535	568	610
	Throw in ft.	11	12	14	15	15	17	18
42 x 4.5 An 1.312	CFM ea. side	525	591	656	722	788	853	919
	Throw in ft.	13	14	16	17	19	20	22

All data are tested in accordance with ANSI/ASHRAE 70-1991

### Definition of Units:

- CFM - Cubic feet per minute (air)
- fpm - Velocity of air stream in feet per minute
- Pt - Total pressure (inches of water column)
- Throw - Cataloged throw is horizontal distances in feet to the terminal velocities of 50 fpm with ambient supply air temperature.
- An - Neck area

## Series L-5000 - Specification

Linear ceiling diffusers shall be model L-5000 manufactured by METALAIRE. Units shall be aluminum construction and consist of a fixed pattern louvered core fastened into a border with spring loaded latches. Optional: Units shall be designed to be configured as a combination supply/return unit.

Core shall be removable without the use of tools. Outlets shall be engineered for high capacity applications and include straight deflector blades (without a horizontal lip). Units with a horizontal lip at the ends of the deflector blades are not acceptable. The units shall be the size and quantity as outline in the plans and specifications.

Outlets shall be available in a 1 or 2 way opposite discharge pattern. Units shall be designed to integrate into the specified ceiling system.

### Options:

#### IV Induction Vanes

Units shall include IV induction vanes factory mounted onto the back side of the deflector vanes. IV vanes shall increase the induction rate of the diffuser.

### Performance Specification

The manufacturer shall provide published performance data. Data shall be tested in accordance to ANSI/ASHRAE Standard 70-1991.

### Paint Specification

Process shall be anodic electrodeposition using an anodic acrylic paint. Units shall undergo pre-treatment including a pressurized spray stage using an alkaine cleaner and a de-ionize water rinse.

Film Properties shall meet or exceed the following standards:

Property	Test Method	Performance
Film thickness		.8-1.0 mils
Film Cure		320 F @ 20 min
Gloss – 60 deg.	ASTM D523-89	70-80%
Pencil Hardness	ASTM D3363-92A	HB-H
Crosshatch Adhesion	ASTM D3359-95	4B-5B
Direct Impact	ASTM D2794-93	100 in.lbs. Min
Reverse Impact	ASTM D2794-93	60 in.lbs. Min.
Salt Spray	ASTM B117-95	48-96 Hours
Humidity	ASTM D1735-92	500 Hours
Water Soak	ASTM D870-92	250 Hours



# LEADING THE INDUSTRY IN PRODUCT LITERATURE

With the choice of our Pre-Flite Catalog, Quick Select Catalog, InfoSource Catalog, InfoSource CD and our web site, [www.metalaire.com](http://www.metalaire.com), you pick the format for product information that best suits your air distribution design needs.

## Pre-Flite - Product Overview Catalog

The METALAIRE Pre-Flite catalog is a condensed reference guide containing concise listings of our entire product line including grilles, registers, diffusers, and air terminal units. This catalog can be used to help select the type of device, along with available border styles. The catalog includes photos of each model along with the features and model guide, a great tool when you are trying to select a device for your project.



## Quick Select Catalog - Air Distribution Selection Made Easy

The METALAIRE Quick Select Catalog is designed to save you time selecting air distribution equipment. This catalog is a compact version of our InfoSource Catalogs and includes drawings and performance for our most popular products. The Quick Select Catalog is broken into product types with each section beginning with a model summary that includes features and benefits of our products. To obtain product information not included in the Quick Select Catalog, simply go to our web site at [www.metalaire.com](http://www.metalaire.com).



## InfoSource Catalog Suite - Complete guide to Air Distribution Selection

The METALAIRE InfoSource Catalog suite is the leading product catalog in the industry. Included in these catalogs are the complete product listings, drawings, product features and benefits, product performance data, specifications, and model specifications. These catalogs are organized to make it quick and easy to find the information you are looking for.

### InfoSource Catalog Suite

- Ceiling Diffusers Catalog
- Grilles & Registers Catalog
- Air Terminal Unit Catalog
- Formations Catalog

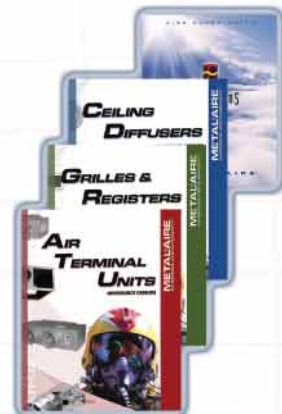

## InfoSource CD

Our InfoSource CD has set the standard in the industry for air distribution product selection. This CD contains a complete library of all our catalogs and submittals along with our air terminal unit selection program.



## Web Site: [www.metalaire.com](http://www.metalaire.com)

METALAIRE leads the industry with a web site that contains all the product literature and performance data needed to design your air distribution system. Our web site includes all our submittals, catalogs, installation manuals, as well as as other valuable information to aid you in air distribution design.



**METALAIRE**  
EXPERIENCE AIRE SUPERIORITY.

PLENUM  
SLOT  
DIFFUSERS

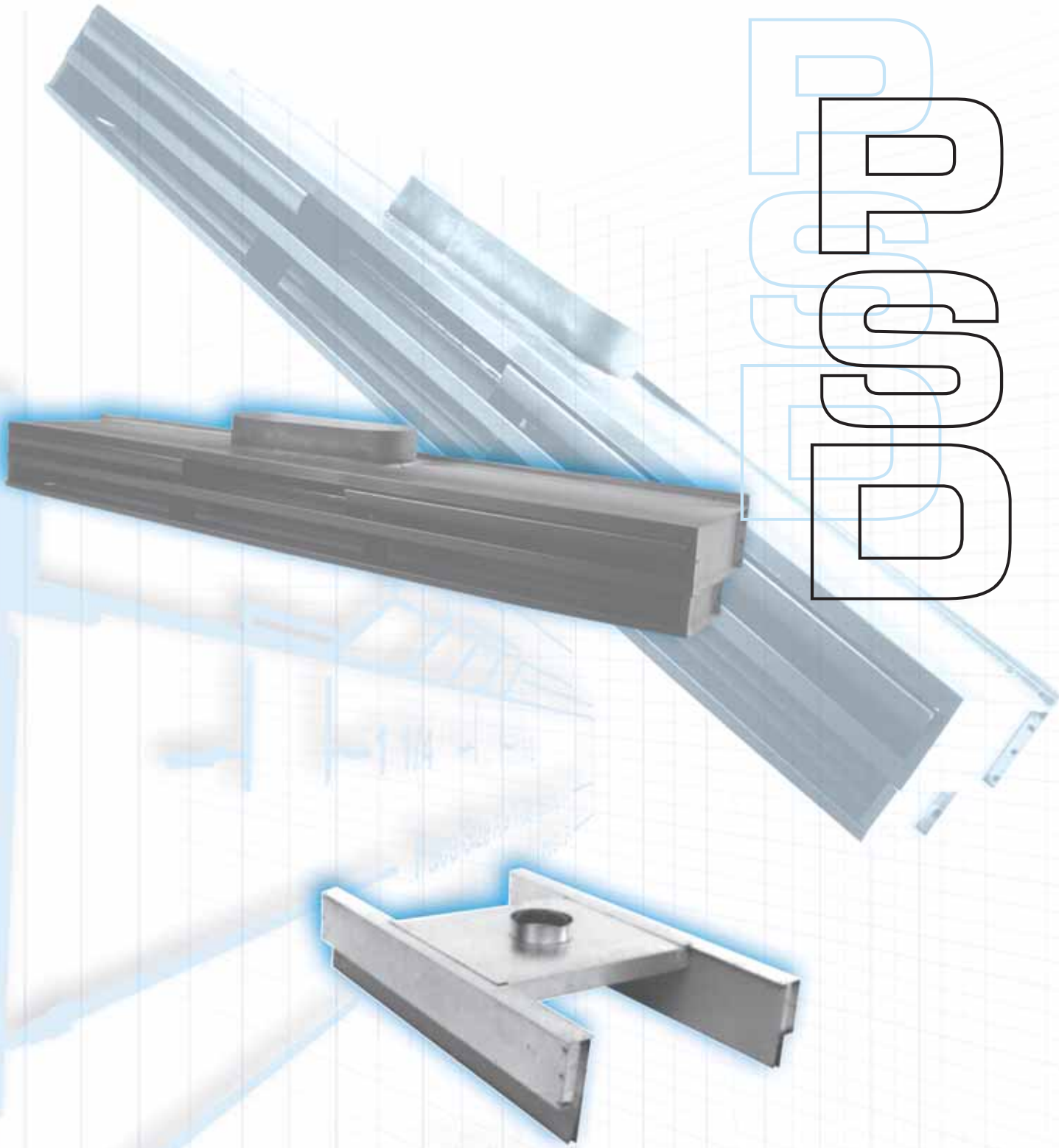

**PLENUM  
SLOT DIFFUSERS**



**Series PHP**  
Pg. 206

## Plenum Slot Diffusers - Adjustable Pattern Controller - Series PHP

- ✦ Heavy duty extruded aluminum pattern controller and gasket for tight horizontal discharge pattern
- ✦ Field adjustable pattern controllers allow adjustable horizontal and vertical throw
- ✦ Units available in 1 to 4 slots to meet a wide range of applications and capabilities
- ✦ Double hem face construction for rigidity and straightness
- ✦ PHPR return model offers low pressure drop return; Integral light shield hides interior of unit
- ✦ One-piece plenum construction ensures tight fit in ceiling grid
- ✦ Optional 1/4" insulation on PHPI-6 units
- ✦ Lay-in (type 6) integrates into 1" T-bar ceiling

	T-bar Lay-in		Fineline Ceilings			
	Supply	Return	Supply		Return	
Insulated	PHPSI-6	PHPRI-6	PHPSI-9 Supply w/ Center Tee	PHNSI-9 Supply w/ hat section	PHPRI-9 Return w/ Center Tee	PHNRI-9 Return w/ hat section
Non-Insulated	PHPS-6	PHPR-6	PHPS-9 Supply w/ Center Tee	PHNS-9 Supply w/ hat section	PHPR-9 Return w/ Center Tee	PHNR-9 Return w/ hat section

Plenum Slot Diffusers



**Series PHC**  
Pg. 224

## High Capacity Plenum Slot Diffusers - Fixed Pattern Controller - Series PHC

- ✦ Aerodynamically shaped, heavy duty extruded aluminum curved blade pattern controller generates a tight horizontal discharge pattern
- ✦ Excellent selection for perimeter applications, especially in cold climates because of its high induction ratio
- ✦ Available with integral return, a low cost and efficient solution to return air into the ceiling plenum
- ✦ Optional 1/4" insulation on PHCSI-6, PHCRI-6, PHCSI-DB-6, and PHCRI-DB-6

T-bar Lay-in				
Insulated	PHCSI-6 Supply	PHCRI-6 Supply - with Return	PHCSI-DB-6 Supply - with Down Blow	PHCRI-DB-6 Supply - with Down Blow & Return
Non-Insulated	PHCS-6 Supply	PHCR-6 Supply - with Return	PHCS-DB-6 Supply - with Down Blow	PHCR-DB-6 Supply - with Down Blow & Return

PSD

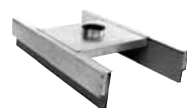

**Series LT**  
Pg. 230

## Light Troffer Diffusers - Fixed Pattern Controller - Series LT

- ✦ Architecturally pleasing; Reduces ceiling clutter by integrating the ceiling diffuser into the light fixture
- ✦ Each unit is customized to fit the specified light fixture ensuring a tight seal for optimum performance
- ✦ Optional 1/2" internal insulation available
- ✦ Available with single or double-sided supply configurations
- ✦ Model DS-LT-6 double-sided diffusers are available with side or top inlet for installation flexibility
- ✦ Matching single-sided plenum return unit model SSR-LT-6 is available

T-bar Lay-in				
Insulated	SSI-LT-6 Single Side	DSI-LT-6 Double Side - Side Inlet	DSTI-LT-6 Double Side - Top Inlet	SSRI-LT-6 Single Side Return
Non-Insulated	SS-LT-6 Single Side	DS-LT-6 Double Side - Side Inlet	DST-LT-6 Double Side - Top Inlet	SSR-LT-6 Single Side Return

# LEADING THE INDUSTRY IN PRODUCT LITERATURE

With the choice of our Pre-Flite Catalog, Quick Select Catalog, InfoSource Catalog, InfoSource CD and our web site, [www.metalaire.com](http://www.metalaire.com), you pick the format for product information that best suites your air distribution design needs.

## Pre-Flite - Product Overview Catalog

Our Pre-Flite catalog is a condensed reference guide containing the listing of our complete product offers for grilles, registers, diffusers, and air terminal units. This catalog can be used to help select the type of device, along with available border styles. The catalog includes photos of each model along with the features and model guide, a great tool when you are trying to select a device for your project.



## Quick Select Catalog - Air Distribution Selection Made Easy

The METALAIRES Quick Select Catalog is designed to save you time selecting air distribution equipment. This catalog is a compact version of our InfoSource Catalog and includes drawings and performance for our most popular products. The Quick Select Catalog is broken into product types with each section beginning with a model summary that includes features and benefits of our products. To obtain product information not included in the Quick Select Catalog, simply go to our web site at [www.metalaire.com](http://www.metalaire.com).



## InfoSource Catalog Suite - Complete guide to Air Distribution Selection

The METALAIRES InfoSource Catalog is the leading product catalog in the industry. Included in this catalog are the complete product listings, drawings, product features and benefits, product performance data, specifications, and model specifications. This catalog is organized to make it quick and easy to find the information you are looking for.



## InfoSource CD

Our InfoSource CD has set the standard in the industry for air distribution product selection. This CD contains a complete library of all our catalogs and submittals along with our air terminal unit selection program.



## Web Site: [www.metalaire.com](http://www.metalaire.com)

METALAIRES leads the industry with a web site that contains all the product literature and performance data needed to design your air distribution system. Our web site includes all our submittals, catalogs, installation manuals, as well as as other valuable information to aid you in air distribution design.



**METALAIRES**  
EXPERIENCE AIRE SUPERIORITY.



## ➔ Plenum Slot Diffusers ➔ Supply/Return ➔ Series PHP

### Product Details

- ★ Heavy duty extruded aluminum pattern controller and gasket for tight horizontal discharge pattern
- ★ Field adjustable pattern controllers allow adjustable horizontal and vertical throw
- ★ Units available in 1 to 4 slots to meet a wide range of applications and capabilities
- ★ Double hem face construction for rigidity and straightness
- ★ PHPR return model offers low pressure drop return; Integral light shield hides interior of unit
- ★ One-piece plenum construction ensures tight fit in ceiling grid
- ★ Optional 1/4" insulation on PHPI-6 units
- ★ Lay-in (type 6) integrates into 1" T-bar ceiling



**Model PHP-6 Shown**

Finish: 25 - WT - White Tees with Black Borders & Plenum Interior

Plenum Slot Diffusers

PSD

### T-bar Lay-in - Supply

Dimensions are in inches

#### Adjustable Pattern Controller

##### Non Insulated

Model PHPS-50-6 - 1/2" Slot Width  
 Model PHPS-75-6 - 3/4" Slot Width  
 Model PHPS-10-6 - 1" Slot Width  
 Model PHPS-15-6 - 1 1/2" Slot Width

##### Insulated

Model PHPSI-50-6 - 1/2" Slot Width  
 Model PHPSI-75-6 - 3/4" Slot Width  
 Model PHPSI-10-6 - 1" Slot Width  
 Model PHPSI-15-6 - 1 1/2" Slot Width

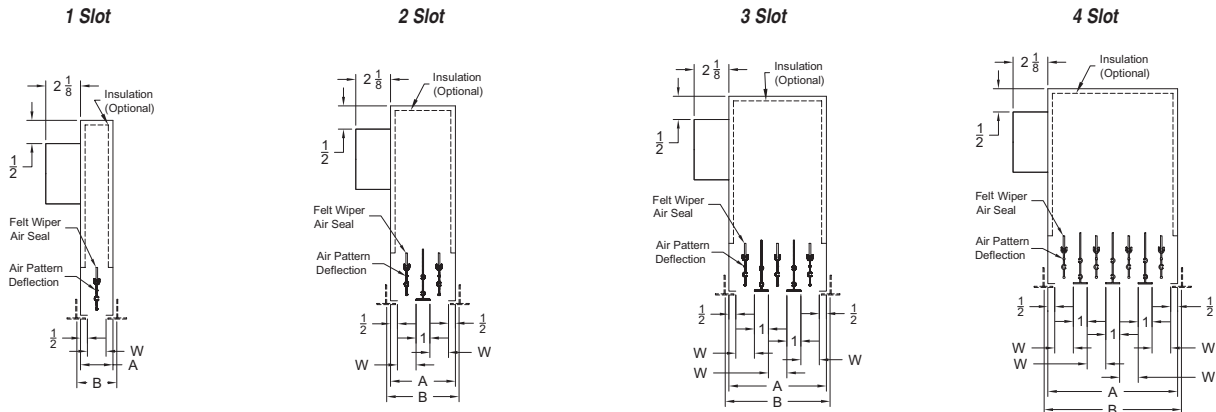

### Supply - Plenum Slot Diffusers - Steel - Face View Series PHPS(I)-6 - T-bar Lay-in

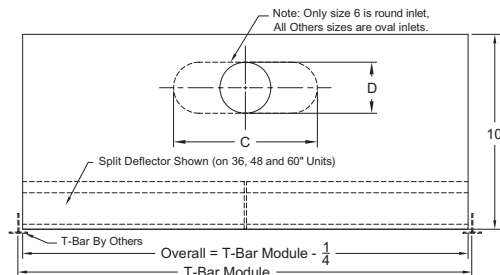

# PSD - Plenum Slot Diffusers

## T-bar Lay-in - Return

Dimensions are in inches

### No Pattern Controller

#### Non Insulated

Model PHPR-50-6 - 1/2" Slot Width  
 Model PHPR-75-6 - 3/4" Slot Width  
 Model PHPR-10-6 - 1" Slot Width  
 Model PHPR-15-6 - 1 1/2" Slot Width

#### Insulated

Model PHPRI-50-6 - 1/2" Slot Width  
 Model PHPRI-75-6 - 3/4" Slot Width  
 Model PHPRI-10-6 - 1" Slot Width  
 Model PHPRI-15-6 - 1 1/2" Slot Width

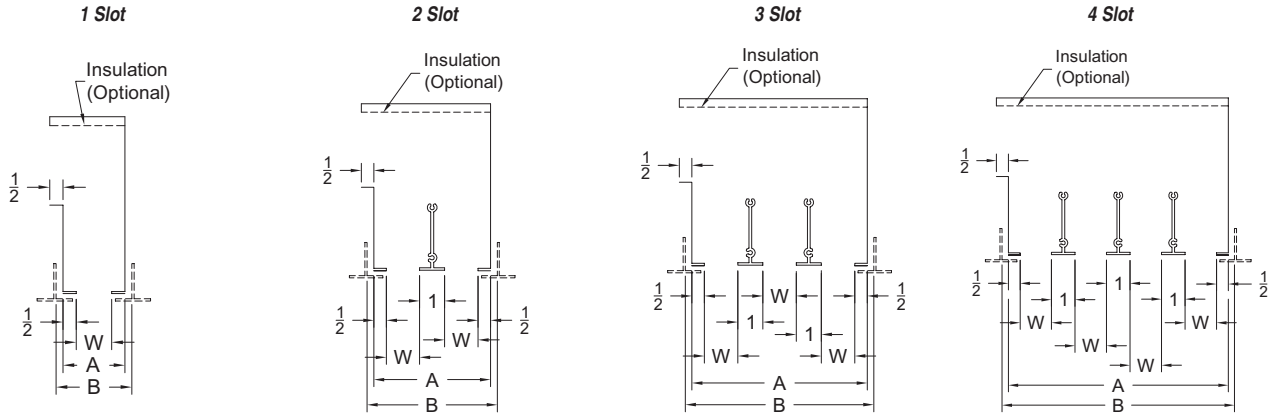

### Return- Plenum Slot Diffusers - Face View

Series PHPR(I)-6 - T-bar Lay-in

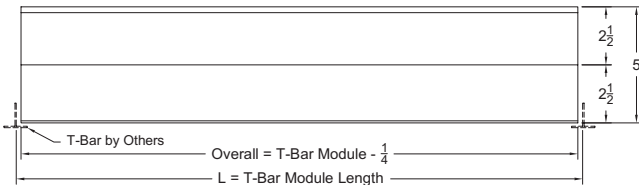

Plenum Slot Diffusers

PSD

Inlet Size	C	D
6 Round	-	5 7/8
8 Oval	8 15/16	6
10 Oval	12 1/16	6
12 Oval	15 1/4	6

Models		L	W	1 Slot		2 Slots		3 Slots		4 Slots	
Supply	Return			A	B	A	B	A	B	A	B
PHPS(I)-50-6	PHPR(I)-50-6	24, 36, 48, 60	1/2	1 1/2	1 3/4	3	3 1/4	4 1/2	4 3/4	6	6 1/4
PHPS(I)-75-6	PHPR(I)-75-6	24, 36, 48, 60	3/4	1 3/4	2	3 1/2	3 3/4	5 1/4	5 1/2	7	7 1/4
PHPS(I)-10-6	PHPR(I)-10-6	24, 36, 48, 60	1	2	2 1/4	4	4 1/4	6	6 1/4	8	8 1/4
PHPS(I)-15-6	PHPR(I)-15-6	24, 36, 48, 60	1 1/2	2 1/2	2 3/4	5	5 1/4	7 1/2	7 3/4	10	10 1/4

## Donn Finline Ceiling - Supply - Adjustable Pattern Controller

### Non Insulated

Model PHPS-75-9 - 3/4" Slot Width  
 Model PHPS-10-9 - 1" Slot Width  
 Model PHPS-15-9 - 1 1/2" Slot Width

### Insulated

Model PHPSI-75-9 - 3/4" Slot Width  
 Model PHPSI-10-9 - 1" Slot Width  
 Model PHPSI-15-9 - 1 1/2" Slot Width

### Non Insulated

Model PHNS-75-9 - 3/4" Slot Width  
 Model PHNS-10-9 - 1" Slot Width  
 Model PHNS-15-9 - 1 1/2" Slot Width

### Insulated

Model PHNSI-75-9 - 3/4" Slot Width  
 Model PHNSI-10-9 - 1" Slot Width  
 Model PHNSI-15-9 - 1 1/2" Slot Width

1 Slot

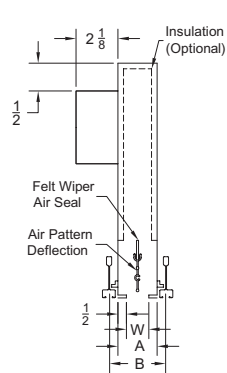

2 Slot - Center Tee

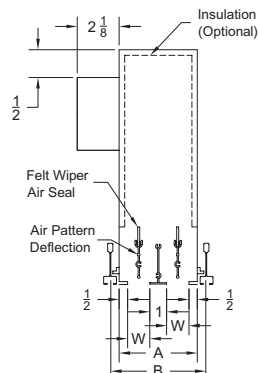

2 Slot - Hat Section

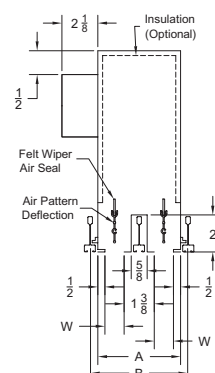

### Supply- Plenum Slot Diffusers - Face View

Series PHPS(I)-9 - Donn Fline Ceiling

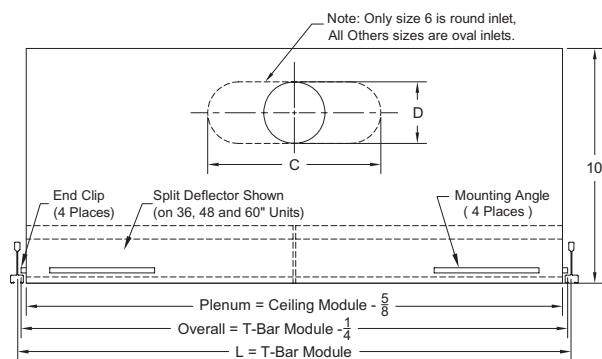

Inlet Size	C	D
6 Round	-	5 7/8
8 Oval	8 15/16	6
10 Oval	12 1/16	6
12 Oval	15 1/4	6

Supply	L	W	1 Slot w/ Center Tee		2 Slots w/ Center Tee		2 Slots w/ Hat Section	
			A	B	A	B	A	B
PHPS(I)-75-9	24, 48	3/4	1 3/4	2 3/8	3 1/2	4 1/8	-	-
PHPS(I)-10-9	24, 48	1	2	2 5/8	4	4 5/8	-	-
PHPS(I)-15-9	24, 48	1 1/2	2 1/2	3 1/8	5	4 5/8	-	-
PHPS(I)-75-9	24, 48	-	-	-	-	-	3 7/8	4 1/4
PHPS(I)-10-9	24, 48	-	-	-	-	-	4 3/8	5
PHPS(I)-15-9	24, 48	-	-	-	-	-	5 3/8	6

# PSD - Plenum Slot Diffusers

## Donn Finline Ceiling - Return - No Pattern Controller

### Non Insulated

Model PHPR-75-9 - 3/4" Slot Width  
 Model PHPR-10-9 - 1" Slot Width  
 Model PHPR-15-9 - 1 1/2" Slot Width

### Insulated

Model PHPRI-75-9 - 3/4" Slot Width  
 Model PHPRI-10-9 - 1" Slot Width  
 Model PHPRI-15-9 - 1 1/2" Slot Width

### Non Insulated

Model PHNR-75-9 - 3/4" Slot Width  
 Model PHNR-10-9 - 1" Slot Width  
 Model PHNR-15-9 - 1 1/2" Slot Width

### Insulated

Model PHNRI-75-9 - 3/4" Slot Width  
 Model PHNRI-10-9 - 1" Slot Width  
 Model PHNRI-15-9 - 1 1/2" Slot Width

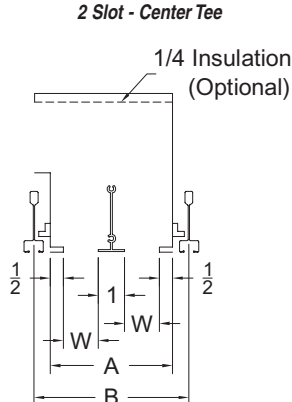
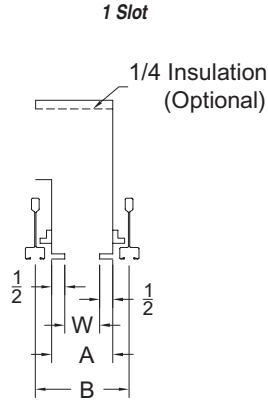

### 2 Slot - Hat Section

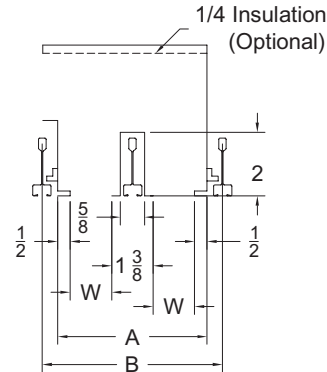

### Return- Plenum Slot Diffusers - Face View

Series PHPR(I)-9 - Donn Finline Ceiling

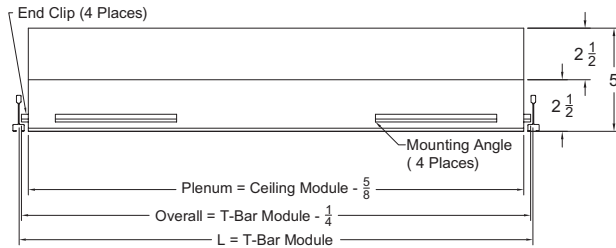

Inlet Size	C	D
6 Round	-	5 7/8
8 Oval	8 15/16	6
10 Oval	12 1/16	6
12 Oval	15 1/4	6

Return	L	W	1 Slot w/ Center Tee		2 Slots w/ Center Tee		2 Slots w/ Hat Section	
			A	B	A	B	A	B
PHPR(I)-75-9	24, 48	3/4	1 3/4	2 3/8	3 1/2	4 1/8	-	-
PHPR(I)-10-9	24, 48	1	2	2 5/8	4	4 5/8	-	-
PHPR(I)-15-9	24, 48	1 1/2	2 1/2	3 1/8	5	4 5/8	-	-
PHPR(I)-75-9	24, 48	-	-	-	-	-	3 7/8	4 1/4
PHPR(I)-10-9	24, 48	-	-	-	-	-	4 3/8	5
PHPR(I)-15-9	24, 48	-	-	-	-	-	5 3/8	6

1. Available Finishes	2. Available Accessories	3. Construction Details
<p><b>Standard Finish:</b> 25-WT White Tees with Black Borders</p> <p><b>Optional Finish</b> 26 White Tees and Borders 27 Black Tees and Borders</p>	<p>CN - (For units over 24")                      LQ - Locking quadrant damper                      T-1 - One outside tee                      T-2 - Two outside tee                      TC-1 - One outside tee                      TC-2 - Bar clips both ends                      TC-3 - One T-bar clip/One outside tee                      EN - End Notch                      EN-2 - End notch/Two outer tees</p>	<ul style="list-style-type: none"> <li>Extruded aluminum pattern controller (supply)</li> <li>No pattern controller on return units</li> <li>One-piece electrogalvanized steel plenum with double hem face</li> <li>Internal insulation is 1/4" on one slot units</li> </ul>

1. Available Finishes	2. Available Accessories	3. Construction Details
<p><b>Standard Finish:</b> 25-WT White Tees with Black Borders</p> <p><b>Optional Finish</b> 26 White Tees and Borders 27 Black Tees and Borders</p>	<p>CN - HS center hat section for 2 slot units (see PHNS models)                      LQ - Locking quadrant damper</p>	<ul style="list-style-type: none"> <li>Extruded aluminum pattern controller on supply units, no pattern controller on return units</li> <li>One-piece electrogalvanized steel plenum with double hem face</li> <li>All -9 units over 24" have a standard cross-notch</li> <li>Internal insulation is 1/4" on one slot units</li> <li>Available in lengths and slot widths as shown</li> </ul>

Plenum Slot Diffusers

PSD



# PSD - Plenum Slot Diffusers

8/2006

## Model PHPS-6 and PHPSI-6 One Slot - Performance

				CFM/LF											
				10	15	25	40	60	75	90	120				
Plenum Slot Diffusers	1/2" Slot Width	2' Length 6" Inlet	Horizontal	CFM	20	30	50	80	120	150	180	240			
			Ps	0.01	0.023	0.064	0.163	0.367	0.574	0.826	1.469				
		Pt	0.011	0.024	0.068	0.174	0.39	0.61	0.879	1.562					
		Throw	2 3 6	3 5 8	5 7 10	7 9 12	9 11 15	10 12 17	11 13 19	12 15 22					
		NC	-	<10	17	29	39	43	47	56					
		Vertical	Ps	0.013	0.029	0.082	0.209	0.471	0.736	1.06	1.885				
	Pt	0.014	0.031	0.086	0.22	0.495	0.773	1.113	1.978						
	Throw	1 1 3	1 2 4	2 3 7	4 5 11	5 8 16	7 10 20	8 12 24	11 16 32						
	NC	-	<10	15	29	38	42	45	52						
	4' Length 6" Inlet	Horizontal	CFM	40	60	100	160	240	300	360	-				
			Ps	0.01	0.023	0.063	0.16	0.36	0.563	0.81	-				
		Pt	0.013	0.028	0.079	0.201	0.453	0.708	1.02	-					
Throw		2 3 7	3 5 10	6 8 14	9 12 18	12 15 22	14 17 24	15 19 26	-						
NC		-	<10	20	32	42	46	50	-						
Vertical		Ps	0.013	0.029	0.08	0.205	0.462	0.722	1.039	-					
Pt	0.015	0.035	0.096	0.247	0.555	0.867	1.249	-							
Throw	2 3 5	3 4 8	4 6 13	7 10 20	10 15 30	13 19 38	15 23 46	-							
NC	-	<10	18	32	41	45	48	-							
5' Length 8" Inlet	Horizontal	CFM	50	75	125	200	300	375	450	-					
		Ps	0.01	0.022	0.061	0.157	0.353	0.551	0.794	-					
	Pt	0.011	0.025	0.07	0.18	0.405	0.633	0.912	-						
	Throw	3 4 8	4 6 12	7 11 16	11 14 20	14 17 24	16 19 27	17 21 29	-						
	NC	<10	11	22	34	44	48	52	-						
	Vertical	Ps	0.013	0.028	0.079	0.201	0.453	0.707	1.018	-					
Pt	0.014	0.032	0.088	0.224	0.505	0.789	1.136	-							
Throw	2 3 7	3 5 10	5 8 16	9 13 26	13 20 40	16 25 49	20 30 59	-							
NC	<10	12	26	39	46	50	55	-							
3/4" Slot Width	2' Length 8" Inlet	Horizontal	CFM	20	30	50	80	120	150	180	240				
			Ps	0.007	0.015	0.041	0.104	0.235	0.367	0.528	0.939				
		Pt	0.007	0.015	0.042	0.108	0.243	0.38	0.973	-					
		Throw	2 3 5	3 4 7	4 6 9	7 8 12	8 10 14	9 11 16	10 12 17	12 14 20					
	NC	-	-	<10	23	32	37	40	47						
	Vertical	Ps	0.008	0.017	0.048	0.123	0.277	0.433	0.623	1.108					
		Pt	0.008	0.018	0.05	0.127	0.285	0.446	0.642	1.141					
	Throw	1 1 2	1 2 3	2 3 5	3 4 9	4 7 13	5 8 16	7 10 20	9 13 26						
	NC	-	-	<10	24	36	41	45	54						
	4' Length 8" Inlet	Horizontal	CFM	40	60	100	160	240	300	360	-				
			Ps	0.006	0.014	0.04	0.102	0.23	0.36	0.518	-				
		Pt	0.007	0.016	0.046	0.117	0.264	0.412	0.593	-					
Throw		2 3 6	3 4 8	5 7 13	7 11 16	11 14 20	13 16 22	14 17 25	-						
NC	-	<10	15	26	35	40	43	-							
Vertical	Ps	0.008	0.017	0.047	0.121	0.272	0.424	0.611	-						
	Pt	0.008	0.019	0.053	0.136	0.305	0.477	0.686	-						
Throw	1 2 4	2 3 6	3 5 10	6 8 17	8 12 25	10 15 31	12 19 37	-							
NC	-	<10	12	27	39	44	48	-							
5' Length 8" Inlet	Horizontal	CFM	50	75	125	200	300	375	450	-					
		Ps	0.006	0.014	0.039	0.1	0.226	0.353	0.508	-					
	Pt	0.008	0.017	0.048	0.124	0.278	0.434	0.626	-						
	Throw	2 4 7	4 6 11	6 9 14	10 13 18	13 16 22	14 18 25	16 19 27	-						
NC	-	<10	17	28	37	42	45	-							
Vertical	Ps	0.007	0.017	0.046	0.118	0.266	0.416	0.599	-						
	Pt	0.009	0.02	0.055	0.142	0.319	0.498	0.717	-						
Throw	2 3 5	3 4 8	4 7 13	7 11 22	11 16 32	13 20 40	16 24 48	-							
NC	-	<10	14	29	41	46	50	-							

See Page PSD-217 for performance data notes

# PSD - Plenum Slot Diffusers

## Model PHPS-6 and PHPSI-6 One Slot - Performance

		CFM/LF																										
		10			15			25			40			60			75			90			120			160		
1" Slot Width	2' Length 8" Inlet	Horizontal	CFM	20	30	50	80	120	150	180	240	320																
			Ps	0.005	0.010	0.028	0.073	0.163	0.255	0.368	0.654	1.162																
			Pt	0.005	0.011	0.030	0.076	0.172	0.268	0.387	0.687	1.222																
		Throw	3 4 6	4 5 7	5 6 9	6 8 11	8 10 14	9 11 15	10 12 17	11 14 19	13 16 23																	
		NC	-	<10	10	23	32	36	39	44	53																	
		Vertical	Ps	0.007	0.016	0.044	0.113	0.254	0.396	0.571	1.015	1.804																
	Pt	0.007	0.016	0.046	0.116	0.262	0.410	0.590	1.048	1.864																		
	Throw	0 1 1	1 1 2	1 2 4	2 3 6	3 4 9	4 5 11	4 7 13	6 9 18	8 12 23																		
	NC	-	-	<10	22	35	40	43	47	55																		
	4' Length 8" Inlet	Horizontal	CFM	40	60	100	160	240	300	360	480																	
			Ps	0.004	0.010	0.028	0.071	0.160	0.250	0.361	0.641																	
			Pt	0.005	0.012	0.034	0.086	0.194	0.303	0.436	0.775																	
		Throw	1 2 4	2 3 7	4 5 11	6 9 16	9 13 19	11 15 22	13 17 24	16 19 28																		
		NC	-	<10	13	26	35	39	42	47																		
		Vertical	Ps	0.007	0.016	0.043	0.111	0.249	0.389	0.560	0.995																	
	Pt	0.008	0.018	0.049	0.125	0.282	0.441	0.635	1.129																			
	Throw	1 2 3	2 2 5	3 4 8	4 6 13	6 10 19	8 12 24	10 14 29	13 19 38																			
	NC	-	-	<10	5	13	18	26	38	43																		
5' Length 10" Inlet	Horizontal	CFM	50	75	125	200	300	375	450	600																		
		Ps	0.004	0.010	0.027	0.070	0.157	0.245	0.353	0.628																		
		Pt	0.005	0.011	0.032	0.082	0.184	0.287	0.413	0.735																		
	Throw	5 6 9	6 8 11	8 10 14	10 13 18	13 15 22	14 17 24	15 19 27	18 22 31																			
	NC	-	<10	15	28	37	41	44	49																			
	Vertical	Ps	0.007	0.015	0.042	0.108	0.244	0.381	0.549	0.975																		
Pt	0.008	0.017	0.047	0.120	0.271	0.423	0.609	1.082																				
Throw	1 2 4	2 3 7	4 5 11	6 9 18	9 13 26	11 16 33	13 20 39	18 26 53																				
NC	-	<10	11	27	40	45	48	52																				
1-1/2" Slot Width	2' Length 8" Inlet	Horizontal	CFM	20	30	50	80	120	150	180	240	320																
			Ps	0.004	0.010	0.027	0.069	0.155	0.242	0.349	0.620	1.102																
			Pt	0.005	0.010	0.028	0.073	0.163	0.255	0.368	0.654	1.162																
		Throw	1 2 3	2 2 5	3 4 8	4 6 11	6 9 13	8 10 15	9 11 16	11 13 18	12 15 21																	
		NC	-	-	<10	13	22	29	34	42	50																	
		Vertical	Ps	0.003	0.007	0.020	0.052	0.117	0.183	0.263	0.468	0.831																
	Pt	0.003	0.008	0.022	0.056	0.125	0.196	0.282	0.501	0.891																		
	Throw	0 1 1	1 1 2	1 1 3	1 2 4	2 3 7	3 4 8	3 5 10	4 7 13	6 9 17																		
	NC	-	-	-	<10	19	25	30	37	45																		
	4' Length 8" Inlet	Horizontal	CFM	40	60	100	160	240	300	360	480	640																
			Ps	0.004	0.009	0.026	0.068	0.152	0.237	0.342	0.608	1.081																
			Pt	0.005	0.012	0.032	0.082	0.186	0.290	0.417	0.742	1.319																
		Throw	2 2 5	2 3 7	4 6 12	6 9 15	9 13 18	12 15 21	13 16 23	15 18 26	17 21 30																	
		NC	-	-	<10	16	25	32	37	45	53																	
		Vertical	Ps	0.003	0.007	0.020	0.051	0.115	0.179	0.258	0.458	0.815																
	Pt	0.004	0.009	0.026	0.066	0.148	0.231	0.333	0.593	1.054																		
	Throw	1 1 2	1 2 4	2 3 6	3 5 10	5 7 14	6 9 18	7 11 21	10 14 29	13 19 38																		
	NC	-	-	<10	12	22	28	33	40	48																		
5' Length 10" Inlet	Horizontal	CFM	50	75	125	200	300	375	450	600	800																	
		Ps	0.004	0.009	0.026	0.066	0.149	0.233	0.335	0.596	1.059																	
		Pt	0.005	0.011	0.031	0.078	0.176	0.275	0.395	0.703	1.249																	
	Throw	3 4 8	4 6 10	7 9 13	10 12 17	12 15 21	13 16 23	15 18 25	17 21 29	19 24 34																		
	NC	-	-	<10	18	27	34	39	47	55																		
	Vertical	Ps	0.003	0.007	0.020	0.050	0.112	0.176	0.253	0.449	0.799																	
Pt	0.004	0.009	0.024	0.062	0.139	0.217	0.313	0.556	0.989																			
Throw	1 2 3	2 2 5	3 4 8	4 7 13	7 10 20	8 12 25	10 15 30	13 20 40	18 27 53																			
NC	-	-	<10	14	24	30	35	42	50																			

See Page PSD-217 for performance data notes

Plenum Slot Diffusers

PSD

# PSD - Plenum Slot Diffusers

8/2006

## Model PHPS-6 and PHPSI-6 - Two Slot - Performance

		CFM/LF											
		10	15	25	40	60	75	90	120	160			
Plenum Slot Diffusers	1/2" Slot Width	2' Length 8" Inlet	Horizontal	CFM	20	30	50	80	120	150	180	240	320
			Ps	0.005	0.012	0.032	0.083	0.186	0.291	0.419	0.745	1.324	
			Pt	0.005	0.012	0.034	0.086	0.195	0.304	0.438	0.778	1.383	
		Throw	1 2 3	2 2 5	3 4 8	4 6 13	6 9 17	8 12 19	9 14 21	13 17 24	16 20 28		
		NC	-	-	<10	15	26	32	37	43	51		
		Vertical	Ps	0.005	0.011	0.029	0.075	0.169	0.264	0.380	0.675	1.200	
	Pt	0.005	0.011	0.031	0.079	0.177	0.277	0.398	0.708	1.259			
	Throw	0 0 2	0 1 3	1 2 6	3 5 9	5 7 14	6 9 17	7 10 21	9 14 28	12 19 37			
	NC	-	-	<10	14	26	33	37	44	51			
	4' Length 8" Inlet	Horizontal	CFM	40	60	100	160	240	300	360	480	640	
		Ps	0.005	0.011	0.032	0.081	0.183	0.285	0.411	0.730	1.298		
		Pt	0.006	0.014	0.038	0.096	0.216	0.338	0.486	0.864	1.536		
Throw		1 2 4	2 3 7	4 5 11	6 9 18	9 13 24	11 16 27	13 20 30	18 24 34	23 28 39			
NC		-	-	<10	18	29	35	40	46	54			
Vertical		Ps	0.005	0.010	0.029	0.074	0.165	0.258	0.372	0.662	1.176		
Pt	0.006	0.012	0.035	0.088	0.199	0.311	0.448	0.796	1.415				
Throw	0 1 2	1 1 5	2 3 8	4 7 13	7 10 20	8 12 24	10 15 29	13 20 39	17 26 52				
NC	-	-	<10	17	29	36	40	47	54				
5' Length 10" Inlet	Horizontal	CFM	50	75	125	200	300	375	450	600	800		
	Ps	0.005	0.011	0.031	0.079	0.179	0.279	0.402	0.715	1.272			
	Pt	0.006	0.013	0.036	0.091	0.206	0.321	0.463	0.822	1.462			
	Throw	2 3 5	3 4 8	4 6 13	7 10 21	10 16 27	13 19 30	16 23 33	21 27 38	25 31 44			
	NC	-	-	<10	20	31	37	42	48	56			
	Vertical	Ps	0.005	0.010	0.028	0.072	0.162	0.253	0.365	0.648	1.153		
Pt	0.005	0.012	0.033	0.084	0.189	0.295	0.425	0.755	1.343				
Throw	0 1 3	1 2 6	2 5 10	5 8 16	8 12 24	10 15 31	12 18 37	16 24 49	22 33 65				
NC	-	-	<10	19	31	38	42	49	56				
PSD	2' Length 8" Inlet	Horizontal	CFM	20	30	50	80	120	150	180	240	320	
		Ps	0.004	0.008	0.023	0.059	0.133	0.208	0.299	0.532	0.946		
		Pt	0.004	0.009	0.025	0.063	0.141	0.221	0.318	0.565	1.005		
		Throw	1 2 3	2 2 5	3 4 8	4 6 12	6 9 17	8 11 19	9 14 21	12 17 24	16 20 28		
		NC	-	-	-	<10	20	26	31	38	44		
		Vertical	Ps	0.003	0.008	0.021	0.054	0.122	0.191	0.275	0.490	0.871	
	Pt	0.004	0.008	0.023	0.058	0.131	0.204	0.294	0.523	0.930			
	Throw	0 0 2	0 1 3	1 2 6	3 5 9	5 7 14	6 9 17	7 10 21	9 14 27	12 18 37			
	NC	-	-	-	<10	17	26	31	37	42			
	3/4" Slot Width	4' Length 8" Inlet	Horizontal	CFM	40	60	100	160	240	300	360	480	640
			Ps	0.004	0.008	0.023	0.058	0.130	0.204	0.293	0.521	0.927	
			Pt	0.005	0.010	0.028	0.073	0.164	0.256	0.369	0.656	1.165	
Throw		2 3 5	3 4 8	4 7 13	7 11 20	11 16 24	13 19 27	16 21 30	20 24 34	23 28 39			
NC		-	-	<10	14	23	29	34	41	47			
Vertical		Ps	0.003	0.008	0.021	0.053	0.120	0.188	0.270	0.480	0.854		
Pt	0.004	0.010	0.027	0.068	0.154	0.240	0.346	0.614	1.092				
Throw	0 1 2	1 1 5	1 3 8	4 6 13	6 10 19	8 12 24	10 14 29	13 19 38	17 25 51				
NC	-	-	-	<10	20	29	34	40	45				
5' Length 10" Inlet	Horizontal	CFM	50	75	125	200	300	375	450	600	800		
	Ps	0.003	0.008	0.022	0.056	0.125	0.196	0.282	0.501	0.890			
	Pt	0.004	0.009	0.026	0.067	0.152	0.237	0.342	0.607	1.080			
	Throw	2 3 5	3 4 8	4 6 13	7 10 21	10 15 27	13 19 30	15 23 33	21 27 38	25 31 44			
	NC	-	-	<10	16	25	31	36	43	49			
	Vertical	Ps	0.003	0.007	0.020	0.051	0.115	0.180	0.259	0.461	0.819		
Pt	0.004	0.009	0.025	0.063	0.142	0.222	0.319	0.568	1.009				
Throw	0 1 3	1 2 6	2 5 10	5 8 15	8 12 23	10 15 29	12 17 35	15 23 46	21 31 62				
NC	-	-	-	<10	22	31	36	42	47				

See Page PSD-217 for performance data notes

# PSD - Plenum Slot Diffusers

## Model PHPS-6 and PHPSI-6 - Two Slot - Performance

		CFM/LF									
		10	15	25	40	60	75	90	120	160	
1" Slot Width	2' Length 8" Inlet	Horizontal	CFM 20	30	50	80	120	150	180	240	320
		Ps	0.002	0.005	0.014	0.035	0.080	0.124	0.179	0.318	0.566
		Pt	0.002	0.005	0.015	0.039	0.088	0.137	0.198	0.352	0.626
		Throw	1 1 3	1 2 4	2 4 7	4 6 12	6 9 17	7 11 19	9 13 21	12 17 24	15 20 28
		NC	-	-	-	<10	17	24	29	35	40
		Vertical	Ps	0.002	0.005	0.013	0.034	0.077	0.120	0.172	0.306
	Pt	0.002	0.005	0.015	0.038	0.085	0.133	0.191	0.340	0.604	
	Throw	0 0 1	0 0 2	0 1 4	1 3 6	3 5 9	4 6 12	5 7 14	6 9 19	8 12 25	
	NC	-	-	-	<10	16	24	30	37	42	
	4' Length 8" Inlet	Horizontal	CFM 40	60	100	160	240	300	360	480	640
		Ps	0.002	0.005	0.014	0.035	0.078	0.122	0.176	0.312	0.555
		Pt	0.003	0.007	0.019	0.050	0.112	0.174	0.251	0.446	0.793
		Throw	1 2 4	2 3 6	4 5 11	6 9 17	9 13 24	11 16 27	13 19 30	17 24 34	23 28 39
		NC	-	-	-	<10	20	27	32	38	43
		Vertical	Ps	0.002	0.005	0.013	0.033	0.075	0.117	0.169	0.300
	Pt	0.003	0.007	0.019	0.048	0.109	0.170	0.244	0.435	0.772	
	Throw	0 0 1	0 1 2	1 2 5	2 4 9	4 7 13	5 8 16	7 10 20	9 13 26	12 18 35	
	NC	-	-	-	<10	19	27	33	40	45	
5' Length 10" Inlet	Horizontal	CFM 50	75	125	200	300	375	450	600	800	
	Ps	0.002	0.005	0.013	0.034	0.076	0.118	0.170	0.303	0.538	
	Pt	0.003	0.006	0.018	0.046	0.102	0.160	0.230	0.410	0.728	
	Throw	2 2 5	2 4 7	4 6 12	7 10 20	10 15 27	12 18 30	15 22 33	20 27 38	25 31 44	
	NC	-	-	<10	11	22	29	34	40	45	
	Vertical	Ps	0.002	0.005	0.013	0.032	0.073	0.114	0.164	0.291	0.518
Pt	0.003	0.006	0.017	0.044	0.100	0.156	0.224	0.398	0.708		
Throw	0 0 1	0 1 3	1 2 7	3 5 11	5 8 16	7 10 20	8 12 24	11 16 32	14 21 43		
NC	-	-	-	<10	21	29	35	42	47		
1-1/2" Slot Width	2' Length 8" Inlet	Horizontal	CFM 20	30	50	80	120	150	180	240	320
		Ps	0.001	0.002	0.007	0.018	0.040	0.062	0.089	0.159	0.282
		Pt	0.001	0.003	0.008	0.021	0.048	0.075	0.108	0.192	0.342
		Throw	1 1 3	1 2 4	2 3 7	4 5 11	5 8 16	7 10 19	8 12 21	11 16 24	14 20 28
		NC	-	-	-	<10	12	17	21	29	37
		Vertical	Ps	0.001	0.002	0.006	0.014	0.033	0.051	0.073	0.130
	Pt	0.001	0.003	0.007	0.018	0.041	0.064	0.092	0.164	0.291	
	Throw	0 0 0	0 0 1	0 0 2	1 1 4	1 3 7	2 4 8	3 5 10	4 7 13	6 9 18	
	NC	-	-	-	-	<10	10	15	23	30	
	4' Length 10" Inlet	Horizontal	CFM 40	60	100	160	240	300	360	480	640
		Ps	0.001	0.002	0.007	0.017	0.039	0.060	0.087	0.154	0.274
		Pt	0.002	0.003	0.010	0.025	0.056	0.087	0.125	0.223	0.396
		Throw	2 2 5	2 3 7	4 6 12	6 9 19	9 14 24	12 17 27	14 21 30	19 24 34	23 28 39
		NC	-	-	-	<10	15	20	24	32	40
		Vertical	Ps	0.001	0.002	0.005	0.014	0.032	0.049	0.071	0.127
	Pt	0.001	0.003	0.008	0.022	0.049	0.076	0.110	0.195	0.347	
	Throw	0 0 0	0 0 1	0 1 2	1 1 6	1 3 9	2 5 11	3 7 14	6 9 18	8 12 20	
	NC	-	-	-	-	<10	13	18	26	33	
5' Length 12" Inlet	Horizontal	CFM 50	75	125	200	300	375	450	600	800	
	Ps	0.001	0.002	0.006	0.016	0.037	0.058	0.083	0.148	0.263	
	Pt	0.001	0.003	0.009	0.024	0.053	0.083	0.120	0.213	0.378	
	Throw	2 2 5	2 4 7	4 6 12	6 9 19	9 14 27	12 18 30	14 21 33	19 27 38	25 31 44	
	NC	-	-	<10	11	17	22	26	34	42	
	Vertical	Ps	0.001	0.002	0.005	0.014	0.030	0.047	0.068	0.122	0.216
Pt	0.001	0.003	0.008	0.021	0.047	0.073	0.105	0.186	0.331		
Throw	0 0 1	0 0 1	0 1 4	1 2 8	2 6 12	4 7 15	6 9 18	8 12 23	10 16 31		
NC	-	-	-	<10	11	15	20	28	35		

See Page PSD-217 for performance data notes

Plenum Slot Diffusers

PSD

# PSD - Plenum Slot Diffusers

8/2006

## Model PHPS-6 and PHPSI-6 - Three Slot - Performance

		CFM/LF											
		25	40	60	80	100	120	160	200	250			
Plenum Slot Diffusers	1/2" Slot Width	2' Length 8" Inlet	Horizontal	CFM	50	80	120	160	200	240	320	400	500
			Ps	0.012	0.030	0.068	0.121	0.188	0.271	0.483	0.754	1.178	
			Pt	0.013	0.034	0.076	0.136	0.212	0.305	0.542	0.847	1.324	
		Throw	4 6 12	6 9 15	9 13 19	12 15 21	14 17 24	15 19 26	18 21 30	20 24 34	22 27 38		
		NC	-	<10	16	23	29	34	41	48	55		
		Vertical	Ps	0.009	0.023	0.052	0.092	0.144	0.207	0.368	0.576	0.900	
	Pt	0.010	0.027	0.060	0.107	0.167	0.241	0.428	0.669	1.045			
	Throw	0 1 3	1 2 7	2 4 11	3 7 15	5 9 18	7 11 21	10 15 25	12 18 27	15 22 31			
	NC	-	<10	11	20	26	31	36	40	46			
	4' Length 8" Inlet	Horizontal	CFM	100	160	240	320	400	480	640	800	1000	
		Ps	0.012	0.030	0.067	0.118	0.185	0.266	0.473	0.739	1.155		
		Pt	0.017	0.044	0.100	0.178	0.278	0.400	0.712	1.112	1.737		
Throw		4 6 12	6 9 19	9 14 26	13 19 30	16 24 34	19 26 37	25 30 43	28 34 48	31 38 54			
NC		<10	11	19	26	32	37	44	51	58			
Vertical		Ps	0.009	0.023	0.051	0.090	0.141	0.203	0.361	0.564	0.882		
Pt	0.015	0.037	0.084	0.150	0.234	0.337	0.600	0.937	1.464				
Throw	0 1 4	1 3 10	3 6 15	4 10 21	7 13 26	10 15 30	14 21 35	17 26 39	21 31 43				
NC	-	<10	14	23	29	34	39	43	49				
5' Length 10" Inlet	Horizontal	CFM	125	200	300	400	500	600	800	1000	1250		
	Ps	0.011	0.029	0.065	0.116	0.181	0.261	0.464	0.724	1.132			
	Pt	0.016	0.041	0.092	0.163	0.255	0.368	0.654	1.021	1.596			
	Throw	4 6 13	7 10 20	10 15 29	13 20 34	17 25 38	20 29 42	27 34 48	31 38 54	35 42 60			
	NC	<10	13	21	28	34	39	46	53	60			
	Vertical	Ps	0.009	0.022	0.050	0.089	0.138	0.199	0.354	0.553	0.864		
Pt	0.013	0.034	0.077	0.136	0.213	0.306	0.544	0.850	1.328				
Throw	1 1 5	1 3 12	3 7 18	6 12 24	9 15 30	12 18 34	16 24 39	21 31 43	25 34 49				
NC	-	<10	16	25	31	36	41	45	51				
3/4" Slot Width	2' Length 8" Inlet	Horizontal	CFM	50	80	120	160	200	240	320	400	500	
		Ps	0.008	0.022	0.049	0.087	0.135	0.195	0.346	0.541	0.845		
		Pt	0.010	0.025	0.057	0.101	0.159	0.228	0.406	0.634	0.991		
		Throw	3 5 9	5 8 15	8 11 19	10 15 21	13 17 24	15 19 26	18 21 30	20 24 34	22 27 38		
		NC	-	-	<10	18	23	27	34	40	45		
		Vertical	Ps	0.006	0.016	0.037	0.066	0.103	0.148	0.263	0.411	0.643	
	Pt	0.008	0.020	0.045	0.081	0.126	0.182	0.323	0.504	0.788			
	Throw	0 0 2	1 1 5	1 3 9	2 5 13	3 7 16	5 9 19	8 13 25	10 16 27	13 20 31			
	NC	-	-	<10	18	26	33	41	47	53			
	4' Length 10" Inlet	Horizontal	CFM	100	160	240	320	400	480	640	800	1000	
		Ps	0.008	0.021	0.048	0.085	0.133	0.191	0.339	0.530	0.829		
		Pt	0.011	0.029	0.065	0.115	0.180	0.259	0.461	0.720	1.126		
Throw		5 7 15	8 12 21	12 18 26	16 21 30	19 24 34	21 26 37	25 30 43	28 34 48	31 38 54			
NC		-	<10	15	21	26	30	37	43	48			
Vertical		Ps	0.006	0.016	0.036	0.065	0.101	0.145	0.258	0.403	0.630		
Pt	0.009	0.024	0.053	0.095	0.148	0.214	0.380	0.593	0.927				
Throw	1 2 7	2 5 13	5 10 19	8 13 25	11 16 27	13 19 30	17 25 35	21 27 39	25 31 43				
NC	-	<10	11	21	29	36	44	50	56				
5' Length 10" Inlet	Horizontal	CFM	125	200	300	400	500	600	800	1000	1250		
	Ps	0.008	0.021	0.047	0.083	0.130	0.187	0.333	0.520	0.812			
	Pt	0.013	0.033	0.074	0.131	0.204	0.294	0.523	0.817	1.276			
	Throw	6 8 17	9 13 24	13 20 29	18 24 34	22 27 38	24 29 42	28 34 48	31 38 54	35 42 60			
	NC	<10	10	17	23	28	32	39	45	50			
	Vertical	Ps	0.006	0.016	0.036	0.063	0.099	0.142	0.253	0.395	0.617		
Pt	0.011	0.028	0.062	0.111	0.173	0.249	0.443	0.692	1.081				
Throw	1 3 10	3 7 16	7 12 23	10 16 27	13 19 31	16 23 34	21 27 39	25 31 43	28 34 49				
NC	-	<10	13	23	31	38	46	52	58				

See Page PSD-217 for performance data notes

# PSD - Plenum Slot Diffusers

## Model PHPS-6 and PHPSI-6 - Three Slot - Performance

		CFM/LF										
		25	40	60	80	100	120	160	200	250		
1" Slot Width	2' Length 10" Inlet	Horizontal	CFM	50	80	120	160	200	240	320	400	500
			Ps	0.005	0.013	0.029	0.052	0.081	0.117	0.208	0.325	0.507
			Pt	0.006	0.015	0.033	0.060	0.093	0.134	0.238	0.372	0.581
		Throw	3 4 8	4 7 13	7 10 19	9 13 21	11 16 24	13 19 26	17 21 30	20 24 34	22 27 38	
		NC	-	-	<10	17	25	31	39	46	54	
		Vertical	Ps	0.004	0.010	0.022	0.039	0.062	0.089	0.158	0.247	0.386
	Pt		0.005	0.012	0.026	0.047	0.074	0.106	0.188	0.294	0.460	
	Throw		0 0 2	0 1 4	1 2 7	2 4 9	3 6 11	4 7 14	6 9 18	8 11 23	10 14 29	
	NC	-	-	<10	14	21	27	35	41	45		
	4' Length 10" Inlet	Horizontal	CFM	100	160	240	320	400	480	640	800	1000
			Ps	0.005	0.013	0.029	0.051	0.080	0.115	0.204	0.318	0.497
			Pt	0.008	0.020	0.046	0.081	0.127	0.183	0.325	0.508	0.794
		Throw	3 5 10	5 8 16	8 12 24	11 16 30	13 20 34	16 24 37	21 30 43	27 34 48	31 38 54	
		NC	-	<10	11	20	28	34	42	49	57	
		Vertical	Ps	0.004	0.010	0.022	0.039	0.060	0.087	0.155	0.242	0.378
	Pt		0.007	0.017	0.039	0.069	0.108	0.156	0.276	0.432	0.675	
	Throw		0 1 3	1 2 7	2 4 11	3 7 14	5 9 18	7 11 21	9 14 28	12 18 36	15 22 43	
	NC	-	-	<10	17	24	30	38	44	48		
5' Length 12" Inlet	Horizontal	CFM	125	200	300	400	500	600	800	1000	1250	
		Ps	0.005	0.012	0.028	0.050	0.078	0.112	0.200	0.312	0.487	
		Pt	0.008	0.020	0.044	0.079	0.123	0.177	0.315	0.492	0.768	
	Throw	4 6 11	6 9 18	9 13 26	12 18 34	15 22 38	18 26 42	24 34 48	29 38 54	35 42 60		
	NC	-	<10	13	22	30	36	44	51	59		
	Vertical	Ps	0.004	0.009	0.021	0.038	0.059	0.085	0.152	0.237	0.370	
Pt		0.007	0.017	0.038	0.067	0.104	0.150	0.267	0.417	0.651		
Throw		1 1 5	1 3 9	3 7 14	6 9 19	8 12 24	9 14 28	13 19 38	16 24 43	20 29 49		
NC	-	<10	12	19	26	32	40	46	50			
1-1/2" Slot Width	2' Length 10" Inlet	Horizontal	CFM	50	80	120	160	200	240	320	400	500
			Ps	0.003	0.006	0.015	0.026	0.041	0.058	0.104	0.162	0.254
			Pt	0.003	0.008	0.019	0.034	0.052	0.076	0.134	0.210	0.328
		Throw	2 3 6	3 5 10	5 7 15	7 10 20	8 12 24	10 15 26	13 20 30	16 24 34	21 27 38	
		NC	-	-	<10	11	15	19	27	33	40	
		Vertical	Ps	0.002	0.005	0.011	0.020	0.031	0.044	0.079	0.123	0.193
	Pt		0.003	0.007	0.015	0.027	0.043	0.062	0.109	0.171	0.267	
	Throw		0 0 1	0 1 3	1 2 4	1 3 6	2 4 7	3 4 9	4 6 12	5 7 15	6 9 18	
	NC	-	-	-	-	-	<10	16	20	24		
	4' Length 12" Inlet	Horizontal	CFM	100	160	240	320	400	480	640	800	1000
			Ps	0.002	0.006	0.014	0.025	0.040	0.057	0.102	0.159	0.249
			Pt	0.004	0.011	0.025	0.044	0.069	0.099	0.175	0.274	0.428
		Throw	2 3 7	4 5 11	5 8 16	7 11 22	9 14 27	11 16 32	14 22 43	18 27 48	23 34 5	
		NC	-	-	<10	14	18	22	30	36	43	
		Vertical	Ps	0.002	0.005	0.011	0.019	0.030	0.044	0.077	0.121	0.189
	Pt		0.004	0.009	0.021	0.038	0.059	0.085	0.151	0.236	0.369	
	Throw		0 0 2	1 1 4	1 3 6	2 4 9	3 5 11	4 6 13	6 9 17	7 11 22	9 14 27	
	NC	-	-	-	-	<10	13	19	23	27		
5' Length 12" Inlet	Horizontal	CFM	125	200	300	400	500	600	800	1000	1250	
		Ps	0.002	0.006	0.014	0.025	0.039	0.056	0.100	0.156	0.244	
		Pt	0.005	0.013	0.030	0.054	0.084	0.121	0.215	0.336	0.524	
	Throw	3 4 9	5 7 14	7 11 22	10 14 29	12 18 36	14 22 42	19 29 48	24 36 54	30 42 60		
	NC	-	<10	12	16	20	24	32	38	45		
	Vertical	Ps	0.002	0.005	0.011	0.019	0.030	0.043	0.076	0.119	0.185	
Pt		0.005	0.012	0.027	0.048	0.075	0.107	0.191	0.298	0.466		
Throw		0 1 3	1 2 6	2 4 9	4 6 11	5 7 14	6 9 17	8 11 23	9 14 28	12 18 35		
NC	-	-	-	<10	11	15	21	25	29			

See Page PSD-217 for performance data notes

Plenum Slot Diffusers

PSD

# PSD - Plenum Slot Diffusers

8/2006

## Model PHPS-6 and PHPSI-6 Four Slot - Performance

			CFM/LF										
			50	75	80	100	150	175	200	250	300		
Plenum Slot Diffusers	1/2" Slot Width	2' Length 8" Inlet	Horizontal	CFM	100	150	160	200	300	350	400	500	-
			P <sub>s</sub>	0.033	0.074	0.084	0.131	0.295	0.401	0.524	0.819	-	
			P <sub>t</sub>	0.039	0.087	0.099	0.154	0.347	0.473	0.617	0.965	-	
		Throw	9 12 16	12 14 20	12 15 21	13 16 23	16 20 28	18 22 30	19 23 33	21 26 36	-		
		NC	<10	15	17	23	35	39	42	48	-		
		Vertical	P <sub>s</sub>	0.029	0.066	0.075	0.117	0.262	0.357	0.466	0.729	-	
	P <sub>t</sub>	0.035	0.079	0.090	0.140	0.315	0.428	0.559	0.874	-			
	Throw	1 2 8	2 5 12	2 5 12	4 8 16	8 12 20	9 14 21	10 16 23	13 18 25	-			
	NC	<10	12	13	20	32	36	39	44	-			
	4' Length 10" Inlet	Horizontal	CFM	200	300	320	400	600	700	800	1000	-	
		P <sub>s</sub>	0.032	0.072	0.082	0.129	0.289	0.394	0.514	0.803	-		
		P <sub>t</sub>	0.044	0.099	0.113	0.176	0.396	0.539	0.704	1.100	-		
Throw		12 16 23	16 20 28	17 21 29	19 23 33	23 28 40	25 30 43	27 33 46	30 36 51	-			
NC		<10	18	20	26	38	42	45	51	-			
Vertical		P <sub>s</sub>	0.029	0.064	0.073	0.114	0.257	0.350	0.457	0.714	-		
P <sub>t</sub>	0.040	0.091	0.104	0.162	0.364	0.496	0.647	1.011	-				
Throw	1 3 11	3 7 16	3 8 17	5 11 22	11 16 28	13 19 30	15 22 32	18 25 36	-				
NC	<10	15	16	23	35	39	42	47	-				
5' Length 10" Inlet	Horizontal	CFM	250	375	400	500	750	875	1000	1250	-		
	P <sub>s</sub>	0.031	0.071	0.081	0.126	0.283	0.386	0.504	0.787	-			
	P <sub>t</sub>	0.050	0.113	0.128	0.200	0.450	0.613	0.801	1.251	-			
	Throw	13 18 26	18 22 31	19 23 33	21 26 36	26 31 45	28 34 48	30 36 51	33 41 58	-			
	NC	11	20	22	28	40	44	47	53	-			
	Vertical	P <sub>s</sub>	0.028	0.063	0.072	0.112	0.252	0.343	0.448	0.700	-		
P <sub>t</sub>	0.047	0.105	0.119	0.186	0.419	0.570	0.745	1.164	-				
Throw	2 4 13	4 9 19	4 10 21	7 13 25	13 19 31	15 22 33	17 25 36	21 28 40	-				
NC	12	17	18	25	37	41	44	49	-				
3/4" Slot Width	2' Length 8" Inlet	Horizontal	CFM	100	150	160	200	300	350	400	500	600	
		P <sub>s</sub>	0.025	0.057	0.065	0.101	0.228	0.311	0.406	0.634	0.913		
		P <sub>t</sub>	0.031	0.070	0.080	0.125	0.281	0.382	0.499	0.780	1.123		
		Throw	9 12 16	12 14 20	12 15 21	13 16 23	16 20 28	18 22 30	19 23 33	21 26 36	23 28 40		
		NC	-	-	<10	18	29	33	36	42	46		
		Vertical	P <sub>s</sub>	0.025	0.057	0.065	0.101	0.227	0.310	0.404	0.632	0.910	
	P <sub>t</sub>	0.031	0.070	0.080	0.124	0.280	0.381	0.498	0.777	1.119			
	Throw	1 1 5	1 3 10	2 3 11	2 5 13	5 10 20	7 12 21	9 13 23	11 17 25	13 20 28			
	NC	-	-	<10	16	29	33	37	41	44			
	4' Length 10" Inlet	Horizontal	CFM	200	300	320	400	600	700	800	1000	1200	
		P <sub>s</sub>	0.025	0.056	0.064	0.099	0.224	0.305	0.398	0.622	0.895		
		P <sub>t</sub>	0.037	0.083	0.094	0.147	0.331	0.450	0.588	0.919	1.323		
Throw		6 12 23	12 19 28	13 20 29	17 23 33	23 28 40	25 30 43	27 33 46	30 36 51	33 40 56			
NC		<10	14	15	21	32	36	39	45	49			
Vertical		P <sub>s</sub>	0.025	0.056	0.063	0.099	0.223	0.304	0.396	0.620	0.892		
P <sub>t</sub>	0.037	0.082	0.094	0.147	0.330	0.449	0.587	0.917	1.320				
Throw	2 5 13	5 10 20	6 11 20	9 13 23	13 20 28	16 21 30	18 23 32	21 25 36	23 28 39				
NC	<10	10	12	19	32	36	40	44	47				
5' Length 10" Inlet	Horizontal	CFM	250	375	400	500	750	875	1000	1250	1500		
	P <sub>s</sub>	0.024	0.055	0.062	0.097	0.219	0.299	0.390	0.609	0.877			
	P <sub>t</sub>	0.043	0.097	0.110	0.172	0.386	0.526	0.687	1.073	1.546			
	Throw	15 18 26	18 22 31	19 23 33	21 26 36	26 31 45	28 34 48	30 36 51	33 41 58	36 45 63			
	NC	<10	16	17	23	34	38	41	47	51			
	Vertical	P <sub>s</sub>	0.024	0.055	0.062	0.097	0.219	0.297	0.389	0.607	0.874		
P <sub>t</sub>	0.043	0.096	0.110	0.171	0.386	0.525	0.686	1.071	1.543				
Throw	4 8 16	8 12 22	9 13 23	11 16 25	16 22 31	19 24 33	21 25 36	23 28 40	25 31 44				
NC	<10	12	14	21	34	38	42	46	49				

See Page PSD-217 for performance data notes

# PSD - Plenum Slot Diffusers

## Model PHPS-6 and PHPSI-6 Four Slot - Performance

		CFM/LF										
		50	75	80	100	150	175	200	250	300		
1" Slot Width	2' Length 10" Inlet	Horizontal	CFM	100	150	160	200	300	350	400	500	600
		Ps	0.017	0.039	0.045	0.070	0.157	0.213	0.279	0.435	0.627	
		Pt	0.020	0.046	0.052	0.082	0.183	0.250	0.326	0.510	0.734	
		Throw	8 12 16	12 14 20	12 15 21	13 16 23	16 20 28	18 22 30	19 23 33	21 26 36	23 28 40	
		NC	-	-	<10	16	29	33	36	41	44	
		Vertical	Ps	0.017	0.037	0.042	0.066	0.149	0.203	0.265	0.414	0.596
	Pt	0.020	0.044	0.050	0.078	0.176	0.239	0.312	0.488	0.703		
	Throw	1 2 6	2 3 9	2 4 9	3 6 11	6 9 17	7 10 20	8 11 23	10 14 25	11 17 28		
	NC	-	-	<10	13	26	31	34	39	43		
	4' Length 10" Inlet	Horizontal	CFM	200	300	320	400	600	700	800	1000	1200
		Ps	0.017	0.038	0.044	0.068	0.154	0.209	0.273	0.427	0.615	
		Pt	0.029	0.065	0.074	0.116	0.261	0.355	0.463	0.724	1.042	
Throw		11 16 23	16 20 28	17 21 29	19 23 33	23 28 40	25 30 43	27 33 46	30 36 51	33 40 56		
NC		<10	11	13	19	32	36	39	46	47		
Vertical		Ps	0.016	0.037	0.042	0.065	0.146	0.199	0.260	0.406	0.584	
Pt	0.028	0.063	0.072	0.112	0.253	0.344	0.450	0.703	1.012			
Throw	1 3 9	3 6 13	3 7 14	5 9 18	9 13 27	10 16 30	12 18 32	15 22 36	18 27 39			
NC	-	-	<10	16	29	34	37	42	46			
5' Length 12" Inlet	Horizontal	CFM	250	375	400	500	750	875	1000	1250	1500	
	Ps	0.017	0.038	0.043	0.067	0.151	0.205	0.268	0.418	0.602		
	Pt	0.028	0.063	0.072	0.112	0.252	0.343	0.447	0.699	1.007		
	Throw	11 17 26	17 22 31	18 23 33	21 26 36	26 31 45	28 34 48	30 36 51	33 41 58	36 45 63		
	NC	<10	13	15	21	34	38	41	46	49		
	Vertical	Ps	0.016	0.036	0.041	0.064	0.143	0.195	0.254	0.398	0.572	
Pt	0.027	0.061	0.069	0.109	0.244	0.332	0.434	0.678	0.977			
Throw	2 5 12	5 9 18	6 9 19	8 12 24	12 18 31	14 21 33	16 24 36	20 28 40	24 31 44			
NC	<10	10	12	18	31	36	39	44	48			
1-1/2" Slot Width	2' Length 10" Inlet	Horizontal	CFM	100	150	160	200	300	350	400	500	600
		Ps	0.016	0.037	0.042	0.066	0.148	0.202	0.264	0.412	0.593	
		Pt	0.019	0.044	0.050	0.078	0.175	0.238	0.311	0.486	0.700	
		Throw	6 10 16	10 14 20	10 15 21	13 16 23	16 20 28	18 22 30	19 23 33	21 26 36	23 28 40	
		NC	-	-	<10	10	19	23	27	33	38	
		Vertical	Ps	0.012	0.028	0.032	0.050	0.112	0.152	0.198	0.310	0.446
	Pt	0.015	0.035	0.039	0.061	0.138	0.188	0.246	0.384	0.553		
	Throw	1 1 3	1 2 4	1 2 5	2 3 6	3 4 9	3 5 10	4 6 12	5 7 15	6 9 18		
	NC	-	-	-	<10	12	17	21	27	31		
	4' Length 12" Inlet	Horizontal	CFM	200	300	320	400	600	700	800	1000	1200
		Ps	0.016	0.036	0.041	0.065	0.145	0.198	0.258	0.404	0.581	
		Pt	0.023	0.053	0.060	0.093	0.210	0.286	0.373	0.583	0.840	
		Throw	4 8 21	8 16 28	10 17 29	14 21 33	21 28 40	25 30 43	27 33 46	30 36 51	33 40 56	
		NC	-	-	<10	13	22	26	30	36	41	
		Vertical	Ps	0.012	0.027	0.031	0.049	0.109	0.149	0.194	0.304	0.437
	Pt	0.019	0.044	0.050	0.077	0.174	0.237	0.309	0.483	0.696		
	Throw	1 2 4	2 3 6	2 3 7	3 4 9	4 6 13	5 8 15	6 9 17	7 11 22	9 13 26		
	NC	-	-	-	<10	15	20	24	30	34		
5' Length 12" Inlet	Horizontal	CFM	250	375	400	500	750	875	1000	1250	1500	
	Ps	0.016	0.036	0.041	0.063	0.142	0.194	0.253	0.396	0.570		
	Pt	0.027	0.061	0.069	0.108	0.244	0.331	0.433	0.676	0.974		
	Throw	7 14 26	14 21 31	15 22 33	19 26 36	26 31 45	28 34 48	30 36 51	33 41 58	36 45 63		
	NC	<10	11	12	15	24	28	32	38	43		
	Vertical	Ps	0.012	0.027	0.030	0.048	0.107	0.146	0.191	0.298	0.429	
Pt	0.023	0.052	0.059	0.093	0.208	0.283	0.370	0.578	0.833			
Throw	1 3 6	3 4 9	3 5 9	4 6 11	6 9 17	7 10 20	8 11 23	9 14 28	11 17 34			
NC	-	-	-	<10	17	22	26	32	36			

**Performance Notes:**

All data are tested in accordance with ANSI/ASHRAE 70-1991

**Definition of Units:**

- CFM - Cubic feet per minute (air)
- Pt - Total pressure (inches of water column)
- Ps - Static pressure = Pt - Pv (inches of water column)
- Throw - Isothermal horizontal throw (supply air temperature the same as average room air temperature) values are for 150 fpm - 100 fpm - 50 fpm velocities
- NC - Noise criterion, sound pressure level. NC ratings are based on sound power level (Lw) RE: 10E-12 watts minus a 10 dB room attenuation in all octave bands

Two-way throw can be determined by dividing the supply air volume in each direction and using the One-way throw values listed. (See example below)

**EXAMPLE:**

PHPS-10-6, 10" inlet 1" Slot, 4-Slot, 4', 2-Way

Determine Ps, NC, and Throw at 600 CFM

1. Find Ps and NC using PHPS-10-6, 1" Slot, 4', 4-Slot data:

Ps = .154

NC = 32

For 2-way throw use PHPS-10-6, 1" Slot, 4', 10" inlet, 1-way, 2-Slot data at 300 CFM.

Horizontal Throw = 11-16-27 in each direction



# PSD - Plenum Slot Diffusers

8/2006

## Models PHPR-6, PHPR-9, PHNR-9 - Performance

Plenum Slot Diffusers

			CFM/LF									
			Negative Ps	10	15	20	25	30	35	40	45	50
			0.016	0.032	0.052	0.076	0.103	0.134	0.168	0.206	0.246	
1/2" Slot Width	2' Length	1 Slot	Airflow	20	30	40	50	60	70	80	90	100
			NC	<15	<15	<15	<15	16	20	24	28	32
		2 Slot	Airflow	40	60	80	100	120	140	160	180	200
			NC	<15	<15	<15	15	19	23	27	31	35
		3 Slot	Airflow	60	90	120	150	180	210	240	270	300
			NC	<15	<15	<15	16	21	25	29	33	36
	4' Length	1 Slot	Airflow	40	60	80	100	120	140	160	180	200
			NC	<15	<15	<15	<15	18	22	26	30	34
		2 Slot	Airflow	80	120	160	200	240	280	320	360	400
			NC	<15	<15	<15	17	21	25	29	33	37
		3 Slot	Airflow	120	180	240	300	360	420	480	540	600
			NC	<15	<15	<15	18	23	27	31	35	38
5' Length	1 Slot	Airflow	50	75	100	125	150	175	200	225	250	
		NC	<15	<15	<15	15	19	23	27	31	35	
	2 Slot	Airflow	100	150	200	250	300	350	400	450	500	
		NC	<15	<15	<15	18	22	26	30	34	38	
	3 Slot	Airflow	150	225	300	375	450	525	600	675	750	
		NC	<15	<15	15	19	24	28	32	36	39	
	4 Slot	Airflow	200	300	400	500	600	700	800	900	1000	
		NC	<15	<15	16	21	25	29	33	37	41	

PSD

			CFM/LF									
			Negative Ps	10	15	20	25	30	40	50	60	70
			0.012	0.024	0.040	0.058	0.079	0.129	0.189	0.257	0.334	
3/4" Slot Width	2' Length	1 Slot	Airflow	20	30	40	50	60	80	100	120	140
			NC	<15	<15	<15	<15	<15	17	24	29	35
		2 Slot	Airflow	40	60	80	100	120	160	200	240	280
			NC	<15	<15	<15	<15	<15	20	27	32	38
		3 Slot	Airflow	60	90	120	150	180	240	300	360	420
			NC	<15	<15	<15	<15	15	22	28	34	39
	4' Length	1 Slot	Airflow	40	60	80	100	120	160	200	240	280
			NC	<15	<15	<15	<15	<15	19	26	31	37
		2 Slot	Airflow	80	120	160	200	240	320	400	480	560
			NC	<15	<15	<15	<15	16	22	29	34	40
		3 Slot	Airflow	120	180	240	300	360	480	600	720	840
			NC	<15	<15	<15	<15	17	24	30	36	41
5' Length	1 Slot	Airflow	50	75	100	125	150	200	250	300	350	
		NC	<15	<15	<15	<15	<15	20	27	32	38	
	2 Slot	Airflow	100	150	200	250	300	400	500	600	700	
		NC	<15	<15	<15	<15	17	23	30	35	41	
	3 Slot	Airflow	150	225	300	375	450	600	750	900	1050	
		NC	<15	<15	<15	15	18	25	31	37	42	
	4 Slot	Airflow	200	300	400	500	600	800	1000	1200	1400	
		NC	<15	<15	<15	16	20	26	33	38	44	

# PSD - Plenum Slot Diffusers

## Models PHPR-6, PHPR-9, PHNR-9 - Performance

			CFM/LF									
			Negative Ps	20	30	40	50	60	70	80	90	100
1" Slot Width	2' Length	1 Slot	Airflow	40	60	80	100	120	140	160	180	200
		NC	<15	<15	<15	15	19	23	26	30	34	
		2 Slot	Airflow	80	120	160	200	240	280	320	360	400
		NC	<15	<15	<15	18	22	26	29	33	37	
		3 Slot	Airflow	120	180	240	300	360	420	480	540	600
		NC	<15	<15	15	19	23	27	31	35	38	
	4 Slot	Airflow	160	240	320	400	480	560	640	720	800	
	NC	<15	<15	16	21	25	29	32	36	40		
	4' Length	1 Slot	Airflow	80	120	160	200	240	280	320	360	400
		NC	<15	<15	<15	17	21	25	28	32	36	
		2 Slot	Airflow	160	240	320	400	480	560	640	720	800
		NC	<15	<15	15	20	24	28	31	35	39	
3 Slot		Airflow	240	360	480	600	720	840	960	1080	1200	
NC		<15	<15	17	21	25	29	33	37	40		
4 Slot	Airflow	320	480	640	800	960	1120	1280	1440	1600		
NC	<15	<15	18	23	27	31	34	38	42			
5' Length	1 Slot	Airflow	100	150	200	250	300	350	400	450	500	
	NC	<15	<15	<15	18	22	26	29	33	37		
	2 Slot	Airflow	200	300	400	500	600	700	800	900	1000	
	NC	<15	<15	16	21	25	29	32	36	40		
	3 Slot	Airflow	300	450	600	750	900	1050	1200	1350	1500	
	NC	<15	<15	18	22	26	30	34	38	41		
4 Slot	Airflow	400	600	800	1000	1200	1400	1600	1800	2000		
NC	<15	15	19	24	28	32	35	39	43			

			CFM/LF									
			Negative Ps	20	30	40	50	60	80	100	125	150
1-1/2" Slot Width	2' Length	1 Slot	Airflow	40	60	80	100	120	160	200	250	300
		NC	<15	<15	<15	<15	17	22	28	36	42	
		2 Slot	Airflow	80	120	160	200	240	320	400	500	600
		NC	<15	<15	<15	<15	17	25	31	39	45	
		3 Slot	Airflow	120	180	240	300	360	480	600	750	900
		NC	<15	<15	<15	15	19	26	33	40	47	
	4 Slot	Airflow	160	240	320	400	480	640	800	1000	1200	
	NC	<15	<15	<15	17	20	28	34	42	48		
	4' Length	1 Slot	Airflow	80	120	160	200	240	320	400	500	600
		NC	<15	<15	<15	<15	16	24	30	38	44	
		2 Slot	Airflow	160	240	320	400	480	640	800	1000	1200
		NC	<15	<15	<15	16	19	27	33	41	47	
3 Slot		Airflow	240	360	480	600	720	960	1200	1500	1800	
NC		<15	<15	<15	17	21	28	35	42	49		
4 Slot	Airflow	320	480	640	800	960	1280	1600	2000	2400		
NC	<15	<15	15	19	22	30	36	44	50			
5' Length	1 Slot	Airflow	100	150	200	250	300	400	500	625	750	
	NC	<15	<15	<15	<15	17	25	31	39	45		
	2 Slot	Airflow	200	300	400	500	600	800	1000	1250	1500	
	NC	<15	<15	<15	17	20	28	34	42	48		
	3 Slot	Airflow	300	450	600	750	900	1200	1500	1875	2250	
	NC	<15	<15	<15	18	22	29	36	43	50		
4 Slot	Airflow	400	600	800	1000	1200	1600	2000	2500	3000		
NC	<15	<15	16	20	23	31	37	45	51			

Plenum Slot Diffusers

PSD

## Series PHP - Specifications

### **Supply - T-bar Lay-in – Insulated/Non Insulated/Model PHCS(I)-6**

Plenum slot supply diffusers shall be METALAIRES PHPS-6 (non-insulated) or PHPSI-6 (insulated). Plenum slot diffusers shall be of the sizes and mounting types as shown on the device schedule.

Diffusers shall have aluminum extruded deflector blades with a gasket tip to seal against the plenum side wall or slot divider. Units shall be adjustable from the slot opening to provide horizontal to vertical air patterns.

Inlets shall be round or oval, centrally located, with a minimum depth of 2 1/8" for ease of duct connection. Units with inlet depths less than 1-3/4" are not acceptable. For straightness and rigidity, plenums shall be fabricated using a single-piece panel construction and have a double metal thickness hem at the face. Plenum diffusers shall be constructed of corrosion resistant galvanized steel. Height of unit shall be 10" or greater to maximize diffuser performance. Units with heights less than 10" are not acceptable.

Units shall be available with 1/2", 3/4", 1", or 1-1/2" slot widths and be available with 1, 2, 3, or 4 independent supply slots. Diffuser face and air pattern controller shall be black. Optional tees shall be white.

Insulated diffusers shall be Model PHPSI. Insulation shall be internal, 1/4" matte face. End caps must be insulated.

### **Return - T-bar Lay-in – Insulated/Non Insulated/Model PHCR(I)-6**

Plenum slot return diffusers shall be METALAIRES PHPR-6 (non-insulated) or PHPRI-6 (insulated). Return diffusers shall be of the sizes and mounting types as shown on the outlet schedule.

Units shall be designed for plenum return applications and match face appearance of the supply diffusers. Units shall include a light shield to minimize reflective light coming through the slot opening.

Plenum return units shall be constructed of corrosion resistant galvanized steel. For straightness and rigidity, plenums shall be fabricated using a double metal thickness hem at the face. Units fabricated without a double metal thickness hem at the face are not acceptable.

Units shall be available with 1/2", 3/4", 1", or 1-1/2" slot widths and be available with 1, 2, 3, or 4 independent supply slots. Diffuser face shall be black. Optional tees shall be white.

### **Supply - Donn Finline Ceilings – Center Tee - Insulated/Non Insulated/Model PHPS(I)-9**

Plenum slot supply diffusers shall be METALAIRES PHPS-9 (non-insulated) or PHPSI-9 (insulated). Plenum slot diffusers shall be of the sizes and mounting types as shown on the device schedule.

Units shall be designed to integrate into 9/16" wide bolt slot or narrow tee systems and include a factory-mounted 1" wide white center tee on two-slot units. Diffusers shall have aluminum extruded deflector blades with a gasket tip to seal against the plenum side wall or slot divider. Units shall be adjustable from the slot opening to provide horizontal to vertical air patterns.

Inlets shall be round or oval, centrally located, with a minimum depth of 2 1/8" for ease of duct connection. Units with inlet depths less than 1-3/4" are not acceptable. For straightness and rigidity, plenums shall be fabricated using a single-piece panel construction and have a double metal thickness hem at the face. Plenum diffusers shall be constructed of corrosion resistant galvanized steel. Height of unit shall be 10" or greater. Units with heights less than 10" are not acceptable.

Units shall be available with 3/4", 1", or 1-1/2" slot widths and be available with 1 or 2 independent supply slots. Diffuser face and air pattern controller shall be white.

Insulated diffusers shall be Model PHPSI. Insulation shall be internal, 1/4" matte face. End caps must be insulated. Units without insulation on end caps will not be accepted.

### **Return - Donn Finline Ceilings – Center Tee - Insulated/Non Insulated/Model PHPR(I)-9**

Plenum slot return diffusers shall be METALAIRES PHPR-9 (non-insulated) or PHPRI-9 (insulated). Return diffusers shall be of the sizes and mounting types as shown on the outlet schedule.

Units shall be designed for plenum return applications and match face appearance of the supply diffusers. Units shall include a light shield to minimize reflective light coming through the slot opening. Units shall be designed to integrate into a 9/16" wide bolt-slot or narrow tee system.

Plenum return units shall be constructed of corrosion resistant galvanized steel. For straightness and rigidity, plenums shall be fabricated with a double metal thickness hem at the face. Units fabricated without a double metal thickness at hem are not acceptable.

Units shall be available with 3/4", 1", or 1-1/2" slot widths and be available with 1 or 2 slots. Diffuser face shall be white. Optional tees shall be white.

## Return - Donn Fineline Ceilings – Center Tee - Insulated/Non Insulated/Model PHPR(I)-9

Plenum slot return diffusers shall be METALAIR PHPR-9 (non-insulated) or PHPRI-9 (insulated). Return diffusers shall be of the sizes and mounting types as shown on the outlet schedule.

Units shall be designed for plenum return applications and match face appearance of the supply diffusers. Units shall include a light shield to minimize reflective light coming through the slot opening. Units shall be designed to integrate into a 9/16" wide bolt-slot or narrow tee system.

Plenum return units shall be constructed of corrosion resistant galvanized steel. For straightness and rigidity, plenums shall be fabricated with a double metal thickness hem at the face. Units fabricated without a double metal thickness at hem are not acceptable.

Units shall be available with 3/4", 1", or 1-1/2" slot widths and be available with 1 or 2 slots. Diffuser face shall be white. Optional tees shall be white.

## Supply - Donn Fineline Ceilings – Hat Section - Insulated/Non Insulated/Model PHNS(I)-9

Plenum slot supply diffusers shall be METALAIR PHNS-9 (non-insulated) or PHNSI-9 (insulated). Plenum slot diffusers shall be of the sizes and mounting types as shown on the device schedule.

Units shall be designed to integrate into 9/16" wide bolt slot or narrow tee systems and include a center hat channel to fit over ceiling tee (by others) on two-slot units. Diffusers shall have aluminum extruded deflector blades with a gasket tip to seal against the plenum side wall or slot divider. Units shall be adjustable from the slot opening to provide horizontal to vertical air patterns.

Inlets shall be round or oval, centrally located, with a minimum depth of 2 1/8" for ease of duct connection. Units with inlet depths less than 1-3/4" are not acceptable. For straightness and rigidity, plenums shall be fabricated using a single-piece panel construction and have a double metal thickness hem at the face. Plenum diffusers shall be constructed of corrosion resistant galvanized steel. Height of unit shall be 10" or greater. Units with heights less than 10" are not acceptable.

Units shall be available with 3/4", 1", or 1-1/2" slot widths and be available with 1 or 2 independent supply slots. Diffuser face and air pattern controller shall be white.

Insulated diffusers shall be Model PHPSI. Insulation shall be internal, 1/4" matte face. End caps must be insulated. Units without insulation on end caps will not be accepted.

## Return - Donn Fineline Ceilings – Hat Section - Insulated/Non Insulated/Model PHNR(I)-9

Plenum slot return diffusers shall be METALAIR PHNR-9 (non-insulated) or PHNRI-9 (insulated). Return diffusers shall be of the sizes and mounting types as shown on the outlet schedule.

Units shall be designed for plenum return applications and match face appearance of the supply diffusers. Units shall include a light shield to minimize reflective light coming through the slot opening. Units shall be designed to integrate into a 9/16" wide bolt-slot or narrow tee system.

Plenum return units shall be constructed of corrosion resistant galvanized steel. For straightness and rigidity, plenums shall be fabricated with a double metal thickness hem at the face. Units fabricated without a double metal thickness at hem are not acceptable.

Units shall be available with 3/4", 1", or 1-1/2" slot widths and be available with 1 or 2 slots. Diffuser face shall be white. Optional tees shall be white.

## Performance Specification

The manufacturer shall provide published performance data. Data shall be tested in accordance to ANSI/ASHRAE Standard 70-1991.

## Paint Specification

Process shall be anodic electrodeposition using an anodic acrylic paint. Units shall undergo pre-treatment including a pressurized spray stage using an alkaline cleaner and a de-ionized water rinse.

Film Properties shall meet or exceed the following standards:

Property	Test Method	Performance
Film thickness		.8-1.0 mils
Film Cure		320 F @ 20 min
Gloss – 60 deg.	ASTM D523-89	70-80%
Pencil Hardness	ASTM D3363-92A	HB-H
Crosshatch Adhesion	ASTM D3359-95	4B-5B
Direct Impact	ASTM D2794-93	100 in.lbs. Min
Reverse Impact	ASTM D2794-93	60 in.lbs. Min.
Salt Spray	ASTM B117-95	48-96 Hours
Humidity	ASTM D1735-92	500 Hours
Water Soak	ASTM D870-92	250 Hours

## Series PHP - Model Specification Guide

### Series PHP-6 - Plenum Slot Diffuser - T-bar Lay-in- Supply/Return

Model	Length	Tee		# of Slots	Inlet	Available Finishes	Available Options		
<b>Supply - Adjustable Pattern Controller</b>	24" 36" 48" 60"	CN	Standard (Center tee on 2-4)	1	6" round	Standard	CN	Cross Notch	
<i>Non Insulated</i>		T-1	One Outside Tee	2	8" oval	25 - White Tee/ Black Border	LQ	Locking Quadrant Damper	
PHPS-50-6 - 1/2" Slot Width		T-2	Two Outside Tees	3	10" oval		PH-TBPF	T-bar Plaster Frame	
PHPS-75-6 - 3/4" Slot Width		TC-1	One Outside T-bar Clip	4	12" oval	Optional			
PHPS-10-6 - 1" Slot Width		TC-2	Bar Clips Both Ends			26 - All White			
PHPS-15-6 - 1 1/2" Slot Width			TC-3	One T-bar Clip/One Outside Tee		27 - All Black			
<i>Insulated</i>			EN	End Notch					
PHPSI-50-6 - 1/2" Slot Width			EN-2	End Notch/Two Tees					
PHPSI-75-6 - 3/4" Slot Width									
PHPSI-10-6 - 1" Slot Width									
PHPSI-15-6 - 1 1/2" Slot Width									
<b>Return - No Pattern Controller</b>									
<i>Non Insulated</i>									
PHPR-50-6 - 1/2" Slot Width									
PHPR-75-6 - 3/4" Slot Width									
PHPR-10-6 - 1" Slot Width									
PHPR-15-6 - 1 1/2" Slot Width									
<i>Insulated</i>									
PHPRI-50-6 - 1/2" Slot Width									
PHPRI-75-6 - 3/4" Slot Width									
PHPRI-10-6 - 1" Slot Width									
PHPRI-15-6 - 1 1/2" Slot Width									

## Series PHP - Model Specification Guide

### Series PHP-9 - Plenum Slot Diffuser - Donn Fineline Ceilings - Supply/Return - Center Tee/Hat Section

Model	Length	# of Slots	Inlet	Available Finishes	Available Options		
Supply - Adjustable Pattern Controller	24"	1	6" round	Standard	LQ Locking Quadrant Damper		
<b>Center Tee - Non Insulated</b> PHPS-75-9 - 3/4" Slot Width PHPS-10-9 - 1" Slot Width PHPS-15-9 - 1 1/2" Slot Width  <b>Hat Section - Non Insulated</b> PHNS-75-9 - 3/4" Slot Width PHNS-10-9 - 1" Slot Width PHNS-15-9 - 1 1/2" Slot Width  <b>Center Tee - Insulated</b> PHPSI-75-6 - 3/4" Slot Width PHPSI-10-6 - 1" Slot Width PHPSI-15-6 - 1 1/2" Slot Width  <b>Hat Section - Insulated</b> PHNSI-75-6 - 3/4" Slot Width PHNSI-10-6 - 1" Slot Width PHNSI-15-6 - 1 1/2" Slot Width	48"	2	8" oval	25 - White Tee/ Black Border			
	10" oval	Optional					
	12" oval	Optional					
		26 - All White					
		27 - All Black					
	Return - No Pattern Controller						
	<b>Center Tee - Non Insulated</b> PHPR-75-9 - 3/4" Slot Width PHPR-10-9 - 1" Slot Width PHPR-15-9 - 1 1/2" Slot Width  <b>Hat Section - Non Insulated</b> PHNR-75-9 - 3/4" Slot Width PHNR-10-9 - 1" Slot Width PHNR-15-9 - 1 1/2" Slot Width  <b>Center Tee - Insulated</b> PHPRI-75-6 - 3/4" Slot Width PHPRI-10-6 - 1" Slot Width PHPRI-15-6 - 1 1/2" Slot Width  <b>Hat Section - Insulated</b> PHNRI-75-6 - 3/4" Slot Width PHNRI-10-6 - 1" Slot Width PHNRI-15-6 - 1 1/2" Slot Width						

# PSD - Plenum Slot Diffusers

8/2006

➔ High Capacity Plenum Slot Diffusers ➔ Fixed Pattern Controller ➔ Series PHC

## Product Details

- ✦ Aerodynamically shaped, heavy duty extruded aluminum curved blade pattern controller generates a tight horizontal discharge pattern
- ✦ Excellent selection for perimeter applications, especially in cold climates because of its high induction ratio
- ✦ Available with integral return, a low cost and efficient solution to return air into the ceiling plenum
- ✦ Optional 1/4" insulation on PHCSI-6, PHCRI-6, PHCSI-DB-6, and PHCRI-DB-6



### Model PHC Shown

Finish: 25 - WT - White Tees with Black Borders & Plenum Interior

Dimensions are in inches

Plenum Slot Diffusers

PSD

### Supply - High Induction Plenum Diffusers - Fixed Curved Blade Non Insulated

Model PHCS-6  
Model PHCS-DB-6 - Center Down Blow  
**Insulated**  
Model PHCSI-6  
Model PHCSI-DB-6 - Center Down Blow

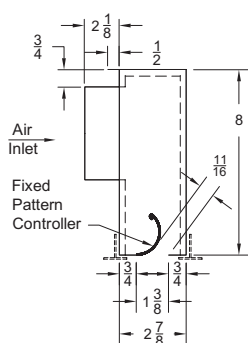

Nominal Lengths	Available Inlets
24	24, 36, 48, 60
36	24, 36, 48, 60
48	24, 36, 48, 60
60	24, 36, 48, 60

### Return - High Induction Plenum Diffusers - Fixed Curved Blade Non Insulated

Model PHCR-6  
Model PHCR-DB-6 - Center Down Blow  
**Insulated**  
Model PHCRI-6  
Model PHCRI-DB-6 - Center Down Blow

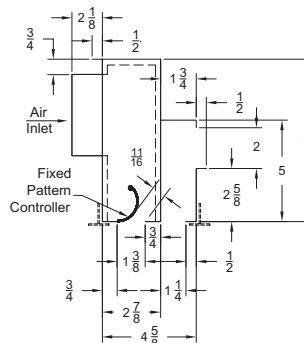

Inlet Size	C	D
6 Round	3 15/16	6 15/16
8 Oval	3 15/16	8 15/16
10 Oval	3 15/16	13 15/16
12 Oval	3 15/16	15 15/16

### High Induction Supply/Return Plenum Diffusers - Louver Face - Fixed Curved Blade - Front View

Series PHCS(I)-6  
Series PHCR(I)-6

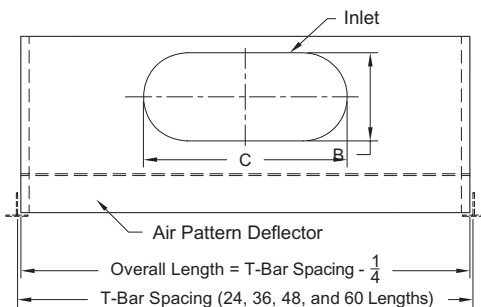

### High Induction Supply/Return Plenum Diffusers - Louver Face - Fixed Curved Blade - Center Down Blow Section - Front View

Series PHCS(I)-6 - Center Down Blow Section  
Series PHCR(I)-6 - Center Down Blow Section

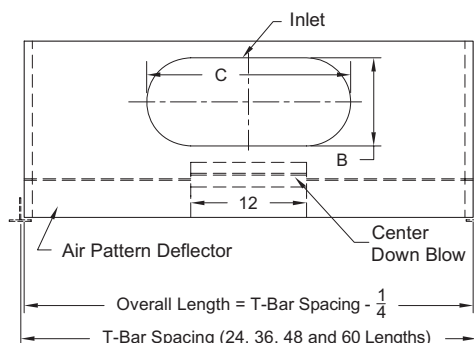

1. Available Finishes	2. Available Accessories	3. Construction Details
Standard Finish: Black Borders	LQ - Locking quadrant damper	<ul style="list-style-type: none"> <li>Extruded aluminum pattern controller</li> <li>One-piece electrogalvanized steel plenum with double hem face</li> <li>Plenum inlets available in 6" round and 8", 10", 12" oval</li> </ul>

# PSD - Plenum Slot Diffusers

## Series PHCS-6 and PHCSI-6 - Performance

		CFM/LF									
		20	30	40	50	60	80	90	100	110	
6" Round Inlet	2' length	CFM	40	60	80	100	120	160	180	200	-
		Ps	0.010	0.022	0.040	0.062	0.089	0.159	0.201	0.248	-
		Pt	0.013	0.028	0.050	0.078	0.113	0.200	0.254	0.313	-
		Throw	1 2 7	2 5 11	4 7 14	6 9 18	7 11 19	10 14 22	11 16 24	12 18 25	-
	3' length	NC	<15	17	21	26	31	39	44	48	-
		CFM	60	90	120	150	180	240	270	300	-
		Ps	0.013	0.029	0.052	0.081	0.117	0.208	0.263	0.324	-
		Pt	0.019	0.042	0.075	0.117	0.169	0.301	0.381	0.470	-
	4' length	Throw	1 3 7	3 5 11	5 7 14	6 9 18	7 11 22	10 14 27	11 16 28	12 18 30	-
		NC	-	<15	16	22	27	36	41	46	-
		CFM	80	120	160	200	240	320	360	400	440
		Ps	0.015	0.033	0.059	0.092	0.132	0.235	0.298	0.368	0.445
5' length	Pt	0.025	0.056	0.100	0.157	0.226	0.401	0.507	0.626	0.758	
	Throw	2 5 10	5 7 14	6 10 19	8 12 24	10 14 27	13 19 31	14 22 33	16 24 35	18 26 36	
	NC	-	<15	<15	19	25	35	40	44	49	
	CFM	100	150	200	250	300	400	450	500	-	
6" Oval Inlet	2' length	Ps	0.015	0.034	0.061	0.095	0.137	0.243	0.308	0.380	-
		Pt	0.031	0.071	0.125	0.196	0.282	0.502	0.635	0.784	-
		Throw	4 6 12	6 9 18	8 12 24	10 15 27	12 18 30	16 24 35	18 26 37	20 27 39	-
		NC	-	<15	16	21	27	36	41	45	-
3' length	CFM	60	90	120	150	180	240	270	300	330	
	Ps	0.009	0.020	0.036	0.056	0.081	0.143	0.181	0.224	0.271	
	Pt	0.011	0.025	0.044	0.069	0.099	0.177	0.224	0.276	0.334	
	Throw	1 2 5	2 4 8	3 5 10	4 6 13	5 8 15	7 10 18	8 11 19	8 13 20	9 14 21	
4' length	NC	-	-	<15	20	25	35	39	44	49	
	CFM	80	120	160	200	240	320	360	400	440	
	Ps	0.011	0.025	0.044	0.069	0.099	0.176	0.223	0.275	0.333	
	Pt	0.015	0.033	0.059	0.092	0.133	0.236	0.299	0.369	0.446	
5' length	Throw	2 3 7	3 5 10	5 7 14	6 8 16	7 10 18	9 14 20	10 15 21	11 16 23	12 17 24	
	NC	-	-	<15	18	23	33	38	43	48	
	CFM	100	150	200	250	300	400	450	500	550	
	Ps	0.013	0.028	0.050	0.079	0.113	0.201	0.255	0.314	0.380	
6" Round Inlet	2' length	Pt	0.018	0.041	0.074	0.115	0.166	0.294	0.373	0.460	0.557
		Throw	3 4 8	4 6 13	6 8 16	7 11 18	8 13 20	11 16 23	13 17 24	14 18 25	15 19 27
		NC	-	-	<15	20	26	35	38	42	46
		CFM	40	60	80	100	120	160	180	200	-
3' length	Ps	0.006	0.014	0.026	0.040	0.058	0.103	0.130	0.161	-	
	Pt	0.007	0.017	0.029	0.046	0.066	0.118	0.149	0.184	-	
	Throw	0 1 3	1 2 5	2 3 7	3 4 8	3 5 10	5 7 14	5 8 15	6 8 16	-	
	NC	-	<15	19	24	28	37	41	46	-	
4' length	CFM	60	90	120	150	180	240	270	300	330	
	Ps	0.009	0.020	0.036	0.056	0.081	0.143	0.181	0.224	0.271	
	Pt	0.011	0.025	0.044	0.069	0.099	0.177	0.224	0.276	0.334	
	Throw	1 2 5	2 4 8	3 5 10	4 6 13	5 8 15	7 10 18	8 11 19	8 13 20	9 14 21	
5' length	NC	-	-	<15	20	25	35	39	44	49	
	CFM	80	120	160	200	240	320	360	400	440	
	Ps	0.011	0.025	0.044	0.069	0.099	0.176	0.223	0.275	0.333	
	Pt	0.015	0.033	0.059	0.092	0.133	0.236	0.299	0.369	0.446	
6" Oval Inlet	2' length	Throw	2 3 7	3 5 10	5 7 14	6 8 16	7 10 18	9 14 20	10 15 21	11 16 23	12 17 24
		NC	-	-	<15	18	23	33	38	43	48
		CFM	100	150	200	250	300	400	450	500	550
		Ps	0.013	0.028	0.050	0.079	0.113	0.201	0.255	0.314	0.380
3' length	Pt	0.018	0.041	0.074	0.115	0.166	0.294	0.373	0.460	0.557	
	Throw	3 4 8	4 6 13	6 8 16	7 11 18	8 13 20	11 16 23	13 17 24	14 18 25	15 19 27	
	NC	-	-	<15	20	26	35	38	42	46	
	CFM	40	60	80	100	120	160	180	200	-	
4' length	Ps	0.006	0.014	0.026	0.040	0.058	0.103	0.130	0.161	-	
	Pt	0.007	0.017	0.029	0.046	0.066	0.118	0.149	0.184	-	
	Throw	0 1 3	1 2 5	2 3 7	3 4 8	3 5 10	5 7 14	5 8 15	6 8 16	-	
	NC	-	<15	19	24	28	37	41	46	-	
5' length	CFM	60	90	120	150	180	240	270	300	330	
	Ps	0.009	0.020	0.036	0.056	0.081	0.143	0.181	0.224	0.271	
	Pt	0.011	0.025	0.044	0.069	0.099	0.177	0.224	0.276	0.334	
	Throw	1 2 5	2 4 8	3 5 10	4 6 13	5 8 15	7 10 18	8 11 19	8 13 20	9 14 21	
6" Round Inlet	2' length	NC	-	-	<15	20	25	35	39	44	49
		CFM	80	120	160	200	240	320	360	400	440
		Ps	0.011	0.025	0.044	0.069	0.099	0.176	0.223	0.275	0.333
		Pt	0.015	0.033	0.059	0.092	0.133	0.236	0.299	0.369	0.446
3' length	Throw	2 3 7	3 5 10	5 7 14	6 8 16	7 10 18	9 14 20	10 15 21	11 16 23	12 17 24	
	NC	-	-	<15	18	23	33	38	43	48	
	CFM	100	150	200	250	300	400	450	500	550	
	Ps	0.013	0.028	0.050	0.079	0.113	0.201	0.255	0.314	0.380	
4' length	Pt	0.018	0.041	0.074	0.115	0.166	0.294	0.373	0.460	0.557	
	Throw	3 4 8	4 6 13	6 8 16	7 11 18	8 13 20	11 16 23	13 17 24	14 18 25	15 19 27	
	NC	-	-	<15	20	26	35	38	42	46	
	CFM	40	60	80	100	120	160	180	200	-	
5' length	Ps	0.006	0.014	0.026	0.040	0.058	0.103	0.130	0.161	-	
	Pt	0.007	0.017	0.029	0.046	0.066	0.118	0.149	0.184	-	
	Throw	0 1 3	1 2 5	2 3 7	3 4 8	3 5 10	5 7 14	5 8 15	6 8 16	-	
	NC	-	<15	19	24	28	37	41	46	-	
6" Oval Inlet	2' length	CFM	60	90	120	150	180	240	270	300	330
		Ps	0.009	0.020	0.036	0.056	0.081	0.143	0.181	0.224	0.271
		Pt	0.011	0.025	0.044	0.069	0.099	0.177	0.224	0.276	0.334
		Throw	1 2 5	2 4 8	3 5 10	4 6 13	5 8 15	7 10 18	8 11 19	8 13 20	9 14 21
3' length	NC	-	-	<15	20	25	35	39	44	49	
	CFM	80	120	160	200	240	320	360	400	440	
	Ps	0.011	0.025	0.044	0.069	0.099	0.176	0.223	0.275	0.333	
	Pt	0.015	0.033	0.059	0.092	0.133	0.236	0.299	0.369	0.446	
4' length	Throw	2 3 7	3 5 10	5 7 14	6 8 16	7 10 18	9 14 20	10 15 21	11 16 23	12 17 24	
	NC	-	-	<15	18	23	33	38	43	48	
	CFM	100	150	200	250	300	400	450	500	550	
	Ps	0.013	0.028	0.050	0.079	0.113	0.201	0.255	0.314	0.380	
5' length	Pt	0.018	0.041	0.074	0.115	0.166	0.294	0.373	0.460	0.557	
	Throw	3 4 8	4 6 13	6 8 16	7 11 18	8 13 20	11 16 23	13 17 24	14 18 25	15 19 27	
	NC	-	-	<15	20	26	35	38	42	46	
	CFM	40	60	80	100	120	160	180	200	-	
6" Round Inlet	2' length	Ps	0.006	0.014	0.026	0.040	0.058	0.103	0.130	0.161	-
		Pt	0.007	0.017	0.029	0.046	0.066	0.118	0.149	0.184	-
		Throw	0 1 3	1 2 5	2 3 7	3 4 8	3 5 10	5 7 14	5 8 15	6 8 16	-
		NC	-	<15	19	24	28	37	41	46	-
3' length	CFM	60	90	120	150	180	240	270	300	330	
	Ps	0.009	0.020	0.036	0.056	0.081	0.143	0.181	0.224	0.271	
	Pt	0.011	0.025	0.044	0.069	0.099	0.177	0.224	0.276	0.334	
	Throw	1 2 5	2 4 8	3 5 10	4 6 13	5 8 15	7 10 18	8 11 19	8 13 20	9 14 21	
4' length	NC	-	-	<15	20	25	35	39	44	49	
	CFM	80	120	160	200	240	320	360	400	440	
	Ps	0.011	0.025	0.044	0.069	0.099	0.176	0.223	0.275	0.333	
	Pt	0.015	0.033	0.059	0.092	0.133	0.236	0.299	0.369	0.446	
5' length	Throw	2 3 7	3 5 10	5 7 14	6 8 16	7 10 18	9 14 20	10 15 21	11 16 23	12 17 24	
	NC	-	-	<15	18	23	33	38	43	48	
	CFM	100	150	200	250	300	400	450	500		



# PSD - Plenum Slot Diffusers

8/2006

## Series PHCS-DB-6 and PHCSI-DB-6 - Performance

Plenum Slot Diffusers

PSD

		CFM/LF										
			20	30	40	50	60	70	80	90	100	110
6" Round Inlet 12" x 7/16" Down blow Slot	3' length	CFM	60	90	120	150	180	210	240	270	-	-
		Ps	0.049	0.111	0.198	0.309	0.445	0.606	0.791	1.001	-	-
		Pt	0.055	0.124	0.221	0.345	0.497	0.677	0.884	1.119	-	-
		Throw, H	1 3 9	3 7 13	6 9 18	7 11 22	9 13 25	10 16 27	12 18 28	13 20 30	-	-
	Throw, V	1 1 2	1 2 4	2 2 5	2 3 5	2 4 6	3 4 6	3 5 7	4 5 7	-	-	
	NC	19	23	28	32	36	40	44	47	-	-	
	4' length	CFM	80	120	160	200	240	280	320	360	-	-
		Ps	0.052	0.116	0.207	0.323	0.465	0.633	0.827	1.047	-	-
		Pt	0.062	0.140	0.248	0.388	0.558	0.760	0.993	1.256	-	-
		Throw, H	2 6 12	6 9 18	8 12 23	10 15 26	12 18 28	14 21 31	16 23 33	18 25 35	-	-
	Throw, V	1 2 3	2 2 5	2 3 5	3 4 6	3 5 7	4 5 7	4 5 8	5 6 8	-	-	
	NC	<15	21	27	33	37	42	46	49	-	-	
5' length	CFM	100	150	200	250	300	350	400	450	-	-	
	Ps	0.020	0.046	0.081	0.127	0.183	0.249	0.325	0.412	-	-	
	Pt	0.037	0.082	0.146	0.228	0.329	0.447	0.584	0.739	-	-	
	Throw, H	4 7 15	7 11 22	10 15 26	12 19 29	15 22 32	17 24 34	20 26 37	22 28 39	-	-	
Throw, V	1 2 4	2 3 5	3 4 6	3 5 7	4 5 7	5 6 8	5 6 8	5 6 9	-	-		
NC	-	<15	20	27	34	39	44	49	-	-		
3' length	CFM	60	90	120	150	180	210	240	270	300	-	
	Ps	0.031	0.069	0.122	0.191	0.275	0.375	0.489	0.619	0.764	-	
	Pt	0.033	0.074	0.131	0.204	0.294	0.400	0.523	0.662	0.817	-	
	Throw, H	1 3 9	3 6 13	6 9 16	7 11 18	9 13 20	10 15 22	11 16 23	13 17 24	14 18 26	-	
Throw, V	1 1 2	1 2 3	1 2 4	2 3 4	2 3 5	2 4 5	3 4 5	3 4 6	3 4 6	-		
NC	15	20	24	28	33	37	40	44	47	-		
8" Oval Inlet 12" x 7/16" Down blow Slot	4' length	CFM	80	120	160	200	240	280	320	360	400	-
		Ps	0.018	0.040	0.071	0.111	0.160	0.218	0.285	0.360	0.445	-
		Pt	0.022	0.048	0.086	0.134	0.194	0.264	0.344	0.436	0.538	-
		Throw, H	2 6 11	6 9 16	8 11 19	9 14 21	11 16 23	13 18 25	15 19 27	16 20 28	17 21 30	-
	Throw, V	1 1 3	1 2 4	2 3 4	2 3 5	3 4 5	3 4 6	4 4 6	4 5 7	4 5 7	-	
	NC	<15	17	23	29	33	37	41	45	49	-	
	5' length	CFM	100	150	200	250	300	350	400	450	500	-
		Ps	0.016	0.035	0.063	0.098	0.141	0.192	0.251	0.317	0.391	-
Pt		0.021	0.048	0.086	0.134	0.193	0.263	0.344	0.435	0.537	-	
Throw, H		4 7 14	7 11 18	9 14 21	12 17 23	14 18 26	16 20 28	17 21 30	18 22 32	19 23 33	-	
Throw, V	1 2 3	2 3 4	2 3 5	3 4 6	3 4 6	4 5 7	4 5 7	4 5 8	5 6 8	-		
NC	-	<15	15	23	29	35	40	44	47	-		

		CFM/LF										
			20	30	40	50	60	70	80	90	100	110
10" Oval Inlet 12" x 7/16" Down blow Slot	3' length	CFM	60	90	120	150	180	210	240	270	300	330
		Ps	0.015	0.034	0.060	0.094	0.136	0.185	0.241	0.305	0.377	0.456
		Pt	0.016	0.036	0.065	0.101	0.145	0.198	0.258	0.327	0.404	0.488
		Throw, H	1 2 6	2 4 8	3 6 11	5 7 14	6 8 17	7 10 19	8 11 21	8 13 22	9 14 23	10 16 24
	Throw, V	1 1 2	1 1 2	1 2 3	1 2 4	2 2 4	2 3 5	2 3 5	2 4 5	3 4 5	3 4 5	
	NC	<15	16	21	25	29	33	37	41	44	47	
	4' length	CFM	80	120	160	200	240	280	320	360	400	440
		Ps	0.015	0.034	0.060	0.093	0.134	0.182	0.238	0.302	0.372	0.451
		Pt	0.017	0.038	0.067	0.105	0.151	0.206	0.269	0.340	0.420	0.508
		Throw, H	1 3 8	3 6 11	5 8 15	6 9 19	8 11 21	9 13 22	10 15 24	11 17 25	13 19 27	14 20 28
	Throw, V	1 1 2	1 2 3	1 2 4	2 3 4	2 3 5	3 4 5	3 4 6	3 4 6	4 4 6	4 5 7	
	NC	-	<15	20	25	30	34	38	41	45	49	
5' length	CFM	100	150	200	250	300	350	400	450	500	-	
	Ps	0.014	0.031	0.055	0.086	0.124	0.169	0.221	0.280	0.345	-	
	Pt	0.017	0.038	0.067	0.105	0.151	0.206	0.269	0.340	0.420	-	
	Throw, H	2 5 9	5 7 14	6 9 19	8 12 21	9 14 23	11 16 25	13 19 27	14 20 29	16 21 30	-	
Throw, V	1 1 3	1 2 4	2 3 4	2 3 5	3 4 5	3 4 6	4 4 6	4 5 7	4 5 7	-		
NC	-	-	<15	21	28	34	39	43	47	-		
12" Oval Inlet 18" x 7/16" Down blow Slot	4' length	CFM	80	120	160	200	240	280	320	360	400	440
		Ps	0.013	0.029	0.051	0.080	0.115	0.157	0.205	0.259	0.320	0.387
		Pt	0.014	0.031	0.056	0.087	0.126	0.171	0.223	0.282	0.349	0.422
		Throw, H	1 3 7	3 5 11	5 7 14	6 9 18	7 11 20	8 12 22	10 14 23	11 16 25	12 18 26	13 19 27
	Throw, V	1 1 2	1 2 3	1 2 4	2 3 4	2 3 5	3 4 5	3 4 6	3 4 6	4 4 6	4 5 7	
	NC	-	<15	18	24	28	32	36	40	43	47	
	5' length	CFM	100	150	200	250	300	350	400	450	500	550
		Ps	0.012	0.027	0.049	0.076	0.109	0.149	0.194	0.246	0.303	0.367
Pt		0.014	0.031	0.056	0.087	0.125	0.171	0.223	0.282	0.348	0.421	
Throw, H		2 4 9	4 7 13	6 9 18	7 11 21	9 13 23	10 16 24	12 18 26	13 20 28	15 21 29	16 22 31	
Throw, V	1 1 3	1 2 4	2 3 4	2 3 5	3 4 5	3 4 6	4 4 6	4 5 7	4 5 7	4 5 7		
NC	-	-	<15	19	26	32	36	41	45	49		

## Performance Notes for Series PHC:

All data are tested in accordance with ANSI/ASHRAE 70-1991

### Definition of Units:

- Horizontal throw values are at terminal velocities of 150, 100, and 50 fpm respectively.
- NC based on  $L_w$  Re  $10^{-12}$  watts and 10dB room absorption. Where no value is shown, NC is less than 15.
- All pressures are in inches, W.G.

## Series PHC - Specifications

### Supply - T-bar Lay-in - Fixed Curved Blade - Insulated/Non Insulated/Model PHCS(I)-6

Plenum slot supply diffusers shall be METALAIRES PHCS-6 (non-insulated) or PHCSI-6 (insulated). Plenum slot diffusers shall be of the sizes and mounting types as shown on the device schedule.

Units shall have an aerodynamically shaped extruded aluminum curved blade deflector that provides a one way horizontal discharge pattern.

Inlets shall be centrally located, with a minimum depth of 2 1/8" for ease of duct connection. For straightness and rigidity, plenums shall be fabricated using a two piece panel construction and have a double metal thickness hem at the face. Units fabricated using single wrapper construction are not acceptable. Plenum diffusers shall be constructed of corrosion resistant galvanized steel.

Diffuser face and air pattern controller shall be black.

Insulated diffusers shall be model PHCSI-6. Insulation shall be internal, 1/4" matte face. End caps must be insulated. Units without insulation on end caps will not be accepted.

### Return - T-bar Lay-in - Fixed Curved Blade - Insulated/Non Insulated/Model PHCR(I)-6

Plenum slot return diffusers shall be METALAIRES PHCR-6 (non-insulated) or PHCRI-6 (insulated). Plenum slot diffusers shall be of the sizes and mounting types as shown on the device schedule.

Plenum diffusers shall include a fixed curved blade supply air section and an integral plenum return section.

The supply section shall have an aerodynamically shaped extruded aluminum curved blade deflector that provides a one way horizontal discharge pattern.

Unit shall have an integral plenum return section designed for plenum return applications. Return section shall include a light shield to minimize reflective light coming through the slot opening.

Inlets shall be centrally located with a minimum depth of 2 1/8" for ease of duct connection. For straightness and rigidity, plenums shall be fabricated using a two piece panel construction and have a double metal thickness hem at the face. Units fabricated using single wrapper construction are not acceptable. Plenum diffusers shall be constructed of corrosion resistant galvanized steel.

Diffuser face and air pattern controller shall be black.

Insulated diffusers shall be model PHCRI-6. Supply section insulation shall be internal 1/4" matte face. End caps on the supply section must be insulated. Units without insulation on supply section end caps will not be accepted.

### Supply - Center Down Blow - T-bar Lay-in - Fixed Curved Blade - Insulated/Non Insulated/Model PHCS(I)-DB-6

Plenum slot supply diffusers shall be METALAIRES PHCS-DB-6 (non-insulated) or PHCSI-DB-6 (insulated). Plenum slot diffusers shall be of the sizes and mounting types as shown on the device schedule.

Plenum diffusers shall include a fixed curved blade supply air section and a center down-blow section. The supply section shall have an aerodynamically shaped extruded aluminum curved blade deflector that provides a one way horizontal discharge pattern.

Plenum slot diffusers shall include an integral adjustable center down-blow section that provides a vertical jet of supply air. Volume and direction of discharge air through center down-blow section shall be adjustable through the face of the diffuser.

Inlets shall be centrally located, with a minimum depth of 2 1/8" for ease of duct connection. For straightness and rigidity, plenums shall be fabricated using a two piece panel construction and have a double metal thickness hem at the face. Units fabricated using single wrapper construction are not acceptable. Plenum diffusers shall be constructed of corrosion resistant galvanized steel.

Diffuser face and air pattern controller shall be black.

Insulated diffusers shall be model PHCSI-DB-6. Supply section insulation shall be internal 1/4" matte face. End caps must be insulated. Units without insulation on end caps will not be accepted.



## Return - Center Down Blow - T-bar Lay-in - Fixed Curved Blade - Insulated/Non Insulated/Model PHCR(I)-DB-6

Plenum slot return diffusers shall be METALAIRE PHCR-DB-6 (non-insulated) or PHCRI-DB-6 (insulated). Plenum slot diffusers shall be of the sizes and mounting types as shown on the device schedule.

Plenum diffusers shall include a supply air section, a center down-blow section, and an integral plenum return section. The supply section shall have an aerodynamically shaped extruded aluminum curved blade deflector that provides a one way horizontal discharge pattern. Plenum slot diffuser shall include an integral adjustable center down-blow section that provides a vertical jet of supply air. Volume and direction of discharge air through center down-blow section shall be adjustable through the face of the diffuser. Unit shall also have an integral plenum return section designed for plenum return applications. Return section shall include a light shield to minimize reflective light coming through the slot opening.

Inlets shall be centrally located, with a minimum depth of 2 1/8" for ease of duct connection. For straightness and rigidity, plenums shall be fabricated using a two piece panel construction and have a double metal thickness hem at the face. Units fabricated using single wrapper construction are not acceptable. Plenum diffusers shall be constructed of corrosion resistant galvanized steel.

Diffuser face and air pattern controller shall be black.

Insulated diffusers shall be model PHCRI-DB-6. Supply section insulation shall be internal 1/4" matte face. End caps on the supply section must be insulated. Units without insulation on supply section end caps will not be accepted.

### Performance Specification

The manufacturer shall provide published performance data. Data shall be tested in accordance to ANSI/ASHRAE Standard 70-1991.

### Paint Specification

Process shall be anodic electrodeposition using an anodic acrylic paint. Units shall undergo pre-treatment including a pressurized spray stage using an alkaline cleaner and a de-ionized water rinse.

Film Properties shall meet or exceed the following standards:

Property	Test Method	Performance
Film thickness		.8-1.0 mils
Film Cure		320 F @ 20 min
Gloss – 60 deg.	ASTM D523-89	70-80%
Pencil Hardness	ASTM D3363-92A	HB-H
Crosshatch Adhesion	ASTM D3359-95	4B-5B
Direct Impact	ASTM D2794-93	100 in.lbs. Min
Reverse Impact	ASTM D2794-93	60 in.lbs. Min.
Salt Spray	ASTM B117-95	48-96 Hours
Humidity	ASTM D1735-92	500 Hours
Water Soak	ASTM D870-92	250 Hours

## Series PHC - Model Specification Guide

Plenum Slot Diffuser - High Induction - Fixed Curved Blade  
Series PHC-6 - T-bar Lay-in

Model	Length	Inlet	Available Finishes	Available Options			
<b>Supply</b>		6" round	Standard	LQ	Locking Quadrant Damper		
PHCS-6 - Non Insulated	24"	8" oval	27 - All Black				
PHCSI-6 - Insulated	36"	10" oval					
<b>Center Down Blow Section</b>	48"	12" oval					
PHCS-DB-6 - Non Insulated	60"						
PHCSI-DB-6 - Insulated							
<b>Return</b>							
PHCR-6 - Non Insulated							
PHCRI-6 - Insulated							
<b>Center Down Blow Section</b>							
PHCR-DB-6 - Non Insulated							
PHCRI-DB-6 - Insulated							



## ➔ Light Troffer Diffusers ➔ Fixed Pattern Controller ➔ Series LT

### Product Details

- ★ Architecturally pleasing; Reduces ceiling clutter by integrating the ceiling diffuser into the light fixture
- ★ Each unit is customized to fit the specified light fixture ensuring a tight seal for optimum performance
- ★ Optional 1/2" internal insulation available
- ★ Available with single or double-sided supply configurations
- ★ Model DS-LT-6 double-sided diffusers are available with side or top inlet for installation flexibility
- ★ Matching single-sided plenum return unit model SSR-LT-6 is available



### Model LT Shown

Finish: 25 - WT - White Tees with Black Borders & Plenum Interior

Plenum Slot Diffusers

PSD

### Single Sided Supply

Dimensions are in inches

Light Troffer Diffuser - Galvanized Steel  
 Single Sided Supply - T-bar Lay-in  
 Model SS-LT-6 - Non Insulated  
 Model SSI-LT-6 - Insulated

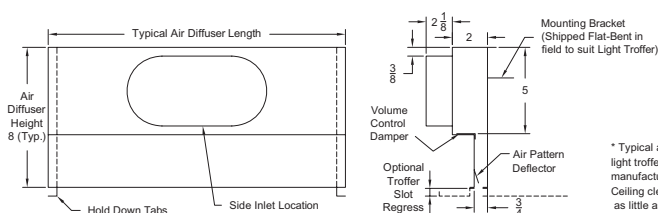

\* Typical air diffuser lengths vary with air handling light troffer manufacturer. Specify the light fixture manufacturer's name and model number on all orders. Ceiling clearance required is typically 8" but can be as little as 6" above the ceiling line.

### Double Sided Supply

Side Inlet - Light Troffer Diffuser - T-bar Lay-in  
 Double Sided Supply - Galvanized Steel  
 Model DS-LT-6 - Non Insulated  
 Model DSI-LT-6 - Insulated

Top Inlet - Light Troffer Diffuser - T-bar Lay-in  
 Double Sided Supply - Galvanized Steel  
 Model DST-LT-6 - Non Insulated  
 Model DSTI-LT-6 - Insulated

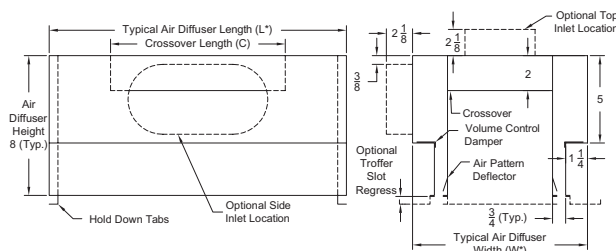

\* Typical air diffuser widths and lengths vary with air handling light troffer manufacturer. Specify the light fixture manufacturer's name and model number on all orders. Ceiling clearance required is typically 8" but can be as little as 6" above the ceiling line. Top inlet units extend above this dimension. Entire diffuser is shipped completely assembled to the job site.

# PSD - Plenum Slot Diffusers

## Single Sided Return

Light Troffer Diffuser - Galvanized Steel

Single Sided Return - T-bar Lay-in

Model SR-LT-6 - *Non Insulated*

Model SRI-LT-6 - *Insulated*

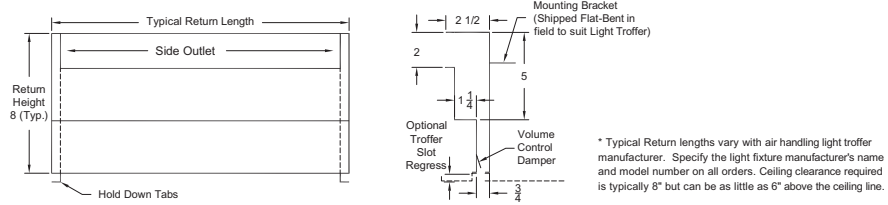

1. Available Finishes	2. Construction Details
<p><b>Standard Finish:</b> 24 Black Edges</p>	<ul style="list-style-type: none"> <li>• Electrogalvanized steel plenum</li> <li>• Plenum inlets available in 4", 5" 6" and 7" (round or oval)</li> <li>• Other sizes may be available</li> </ul>

Plenum Slot Diffusers



PSD

# PSD - Plenum Slot Diffusers

8/2006

## Series SS-LT-6 and SSI-LT-6 - Performance

		CFM/LF																								
		10			15			20			25			30			35			40			50			
Plenum Slot Diffusers	2' length	5" Inlet	Horizontal	CFM	20	30	40	50	60	70	80	100														
			Ps	0.020	0.045	0.081	0.126	0.182	0.247	0.323	0.504															
			Pt	0.022	0.048	0.086	0.134	0.194	0.264	0.344	0.538															
		Throw	2	3	6	3	5	9	4	6	11	5	8	12	6	9	13	7	10	14	9	11	15	10	12	17
		NC	-	<15	15	22	28	33	37	44																
		Vertical	CFM	20	30	40	50	60	70	80	100															
	Ps	0.020	0.045	0.081	0.126	0.182	0.247	0.323	0.504																	
	Pt	0.022	0.048	0.086	0.134	0.194	0.264	0.344	0.538																	
	Throw	1	2	4	2	3	5	2	4	7	3	4	8	4	5	9	4	6	9	5	7	10	6	8	11	
	NC	-	<15	15	22	28	33	37	44																	
	3' length	5" Inlet	Horizontal	CFM	20	30	40	50	60	70	80	100														
			Ps	0.019	0.043	0.077	0.121	0.174	0.237	0.309	0.483															
Pt			0.020	0.045	0.080	0.125	0.180	0.245	0.320	0.499																
Throw		2	3	6	3	5	9	4	6	11	5	8	12	6	9	13	7	10	14	9	11	15	10	12	17	
NC		-	<15	15	22	28	33	37	44																	
Vertical		CFM	20	30	40	50	60	70	80	100																
Ps	0.019	0.043	0.077	0.121	0.174	0.237	0.309	0.483																		
Pt	0.020	0.045	0.080	0.125	0.180	0.245	0.320	0.499																		
Throw	1	2	4	2	3	5	2	4	7	3	4	8	4	5	9	4	6	9	5	7	10	6	8	11		
NC	-	<15	15	22	28	33	37	44																		
4' length	5" Inlet	Horizontal	CFM	30	45	60	75	90	105	120	-															
		Ps	0.024	0.053	0.095	0.148	0.213	0.290	0.379	-																
		Pt	0.027	0.060	0.107	0.167	0.240	0.327	0.427	-																
	Throw	1	2	7	2	5	10	4	7	12	5	8	13	7	10	15	8	11	16	9	12	17	-	-		
	NC	-	<15	18	25	31	37	42	-																	
	Vertical	CFM	30	45	60	75	90	105	120	-																
Ps	0.021	0.048	0.085	0.133	0.192	0.261	0.341	-																		
Pt	0.024	0.055	0.097	0.152	0.219	0.298	0.390	-																		
Throw	1	2	4	2	3	6	3	4	8	3	5	9	4	6	10	5	7	11	5	8	12	-	-			
NC	-	<15	18	25	31	37	42	-																		
5" Inlet	5" Inlet	Horizontal	CFM	30	45	60	75	90	105	120	-															
		Ps	0.024	0.053	0.095	0.148	0.213	0.290	0.379	-																
		Pt	0.025	0.057	0.100	0.157	0.226	0.308	0.402	-																
	Throw	1	2	7	2	5	10	4	7	12	5	8	13	7	10	15	8	11	16	9	12	17	-	-		
	NC	-	<15	18	25	31	37	42	-																	
	Vertical	CFM	30	45	60	75	90	105	120	-																
Ps	0.021	0.048	0.085	0.133	0.192	0.261	0.341	-																		
Pt	0.023	0.051	0.091	0.142	0.205	0.279	0.365	-																		
Throw	1	2	4	2	3	6	3	4	8	3	5	9	4	6	10	5	7	11	5	8	12	-	-			
NC	-	<15	18	25	31	37	42	-																		
6" Inlet	5" Inlet	Horizontal	CFM	40	60	80	100	120	140	-																
		Ps	0.028	0.062	0.111	0.173	0.250	0.340	-																	
		Pt	0.033	0.075	0.132	0.207	0.298	0.406	-																	
	Throw	1	2	6	2	4	9	4	6	10	5	7	12	6	9	13	7	10	14	-	-	-	-			
	NC	-	<15	23	30	37	44	-																		
	Vertical	CFM	40	60	80	100	120	140	-																	
Ps	0.026	0.059	0.105	0.164	0.236	0.321	-																			
Pt	0.032	0.071	0.126	0.197	0.284	0.387	-																			
Throw	1	2	4	2	3	6	3	4	8	3	5	8	4	6	9	5	7	10	-	-	-	-				
NC	-	<15	23	30	37	44	-																			
6" Inlet	5" Inlet	Horizontal	CFM	40	60	80	100	120	140	-																
		Ps	0.028	0.062	0.111	0.173	0.250	0.340	-																	
		Pt	0.030	0.068	0.121	0.190	0.273	0.372	-																	
	Throw	1	2	6	2	4	9	4	6	10	5	7	12	6	9	13	7	10	14	-	-	-	-			
	NC	-	<15	23	30	37	44	-																		
	Vertical	CFM	40	60	80	100	120	140	-																	
Ps	0.026	0.059	0.105	0.164	0.236	0.321	-																			
Pt	0.029	0.065	0.115	0.180	0.259	0.352	-																			
Throw	1	2	4	2	3	6	3	4	8	3	5	8	4	6	9	5	7	10	-	-	-	-				
NC	-	<15	23	30	37	44	-																			

See page PSD-235 for performance data notes

# PSD - Plenum Slot Diffusers

## Series DS-LT-6 and DSI-LT-6 - Top Inlet Performance

		CFM/LF										
		15	20	25	30	35	40	45	50	55	60	
2 x 2 (W x L)	5" Inlet	CFM	30	40	50	60	70	80	90	100	110	120
		Ps	0.014	0.026	0.040	0.057	0.078	0.102	0.129	0.160	0.193	0.230
		Horiz. Pt	0.017	0.031	0.048	0.070	0.095	0.124	0.156	0.193	0.234	0.278
		Throw	0 1 2	0 1 3	1 2 4	1 2 4	1 3 5	2 3 6	2 3 7	2 4 7	3 4 8	3 4 9
		NC	<15	<15	<15	<15	17	21	25	28	32	36
		CFM	30	40	50	60	70	80	90	100	110	120
	Ps	0.014	0.026	0.040	0.057	0.078	0.102	0.129	0.160	0.193	0.230	
	Vert. Pt	0.017	0.031	0.048	0.070	0.095	0.124	0.156	0.193	0.234	0.278	
	Throw	1 1 3	1 2 4	1 3 5	2 3 7	3 4 8	3 4 8	3 5 9	4 5 9	4 6 10	4 7 10	
	NC	<15	<15	<15	<15	17	21	25	28	32	36	
	CFM	30	40	50	60	70	80	90	100	110	120	
	Ps	0.013	0.024	0.037	0.054	0.073	0.096	0.121	0.150	0.181	0.216	
Horiz. Pt	0.015	0.027	0.042	0.060	0.081	0.106	0.135	0.166	0.201	0.239		
Throw	0 1 2	0 1 3	1 2 4	1 2 4	1 3 5	2 3 6	2 3 7	2 4 7	3 4 8	3 4 9		
NC	<15	<15	<15	<15	17	21	25	28	32	36		
CFM	30	40	50	60	70	80	90	100	110	120		
Ps	0.013	0.024	0.037	0.054	0.073	0.096	0.121	0.150	0.181	0.216		
Vert. Pt	0.015	0.027	0.042	0.060	0.081	0.106	0.135	0.166	0.201	0.239		
Throw	1 1 3	1 2 4	1 3 5	2 3 7	3 4 8	3 4 8	3 5 9	4 5 9	4 6 10	4 7 10		
NC	<15	<15	<15	<15	17	21	25	28	32	36		
3 x 3 (W x L)	5" Inlet	CFM	45	60	75	90	105	120	135	150	165	180
		Ps	0.017	0.030	0.048	0.069	0.093	0.122	0.154	0.191	0.231	0.274
		Horiz. Pt	0.024	0.043	0.067	0.096	0.130	0.170	0.215	0.266	0.322	0.383
		Throw	0 1 4	1 2 5	1 2 6	2 4 7	2 4 8	3 5 10	4 5 10	4 6 11	4 7 11	5 7 12
		NC	<15	<15	<15	16	21	25	29	32	35	37
		CFM	45	60	75	90	105	120	135	150	165	180
	Ps	0.017	0.030	0.048	0.069	0.093	0.122	0.154	0.191	0.231	0.274	
	Vert. Pt	0.024	0.043	0.067	0.096	0.130	0.170	0.215	0.266	0.322	0.383	
	Throw	0 1 3	1 2 4	1 2 5	2 3 7	2 4 7	3 4 8	3 5 8	4 5 9	4 6 9	4 7 9	
	NC	<15	<15	<15	16	21	25	29	32	35	37	
	CFM	45	60	75	90	105	120	135	150	165	180	
	Ps	0.015	0.027	0.042	0.061	0.083	0.108	0.137	0.169	0.205	0.244	
Horiz. Pt	0.019	0.033	0.051	0.074	0.101	0.132	0.167	0.206	0.249	0.296		
Throw	0 1 4	1 2 5	1 2 6	2 4 7	2 4 8	3 5 10	4 5 10	4 6 11	4 7 11	5 7 12		
NC	<15	<15	<15	16	21	25	29	32	35	37		
CFM	45	60	75	90	105	120	135	150	165	180		
Ps	0.015	0.027	0.042	0.061	0.083	0.108	0.137	0.169	0.205	0.244		
Vert. Pt	0.019	0.033	0.051	0.074	0.101	0.132	0.167	0.206	0.249	0.296		
Throw	0 1 3	1 2 4	1 2 5	2 3 7	2 4 7	3 4 8	3 5 8	4 5 9	4 6 9	4 7 9		
NC	<15	<15	<15	16	21	25	29	32	35	37		
1 x 4 2 x 4 4 x 4 (W x L)	5" Inlet	CFM	60	80	100	120	140	160	180	200	220	-
		Ps	0.023	0.042	0.065	0.094	0.127	0.166	0.210	0.260	0.314	-
		Horiz. Pt	0.035	0.063	0.099	0.142	0.193	0.252	0.319	0.394	0.477	-
		Throw	1 2 4	2 3 5	2 3 7	3 4 8	3 5 8	4 5 9	4 6 9	4 7 10	5 7 10	-
		NC	<15	<15	16	21	26	30	33	37	41	-
		CFM	60	80	100	120	140	160	180	200	220	-
	Ps	0.023	0.042	0.065	0.094	0.127	0.166	0.210	0.260	0.314	-	
	Vert. Pt	0.035	0.063	0.099	0.142	0.193	0.252	0.319	0.394	0.477	-	
	Throw	0 1 4	1 2 5	1 2 6	2 4 6	2 4 7	3 5 7	4 5 8	4 6 8	4 6 8	-	
	NC	<15	<15	16	21	26	30	33	37	41	-	
	CFM	60	80	100	120	140	160	180	200	220	-	
	Ps	0.021	0.037	0.058	0.083	0.113	0.148	0.187	0.231	0.280	-	
Horiz. Pt	0.027	0.047	0.074	0.107	0.145	0.189	0.240	0.296	0.358	-		
Throw	1 2 4	2 3 5	2 3 7	3 4 8	3 5 8	4 5 9	4 6 9	4 7 10	5 7 10	-		
NC	<15	<15	16	21	26	30	33	37	41	-		
CFM	60	80	100	120	140	160	180	200	220	-		
Ps	0.021	0.037	0.058	0.083	0.113	0.148	0.187	0.231	0.280	-		
Vert. Pt	0.027	0.047	0.074	0.107	0.145	0.189	0.240	0.296	0.358	-		
Throw	0 1 4	1 2 5	1 2 6	2 4 6	2 4 7	3 5 7	4 5 8	4 6 8	4 6 8	-		
NC	<15	<15	16	21	26	30	33	37	41	-		

See page PSD-235 for performance data notes

Plenum Slot Diffusers

PSD



# PSD - Plenum Slot Diffusers

8/2006

## Series DS-LT-6 and DSI-LT-6 - Side Inlet Performance

		CFM/LF											
		15	20	25	30	35	40	45	50	55	60		
Plenum Slot Diffusers	2 x 2 (W x L)	5" Inlet	CFM	30	40	50	60	70	80	90	100	110	120
			Ps	0.016	0.029	0.046	0.066	0.089	0.117	0.148	0.182	0.221	0.263
			Horiz. Pt	0.019	0.035	0.054	0.078	0.106	0.138	0.175	0.216	0.261	0.311
		Throw	0 1 2	0 1 4	1 2 6	1 2 9	1 3 10	2 4 11	2 5 11	3 6 12	3 7 13	4 9 13	
		NC	-	-	-	<15	17	22	26	29	32	36	
		CFM	30	40	50	60	70	80	90	100	110	120	
	Ps	0.016	0.029	0.046	0.066	0.089	0.117	0.148	0.182	0.221	0.263		
	Vert. Pt	0.019	0.035	0.054	0.078	0.106	0.138	0.175	0.216	0.261	0.311		
	Throw	1 1 3	1 2 4	2 3 5	2 3 6	2 4 7	3 4 8	3 5 8	3 5 9	4 6 9	4 6 10		
	NC	-	-	-	<15	17	22	26	29	32	36		
	6" Inlet	CFM	30	40	50	60	70	80	90	100	110	120	
			Ps	0.014	0.025	0.040	0.057	0.078	0.102	0.129	0.159	0.193	0.229
Horiz. Pt			0.016	0.028	0.044	0.063	0.086	0.112	0.142	0.175	0.212	0.253	
Throw		0 1 2	0 1 4	1 2 6	1 2 9	1 3 10	2 4 11	2 5 11	3 6 12	3 7 13	4 9 13		
NC		-	-	-	<15	17	22	26	29	32	36		
CFM		30	40	50	60	70	80	90	100	110	120		
Ps	0.014	0.025	0.040	0.057	0.078	0.102	0.129	0.159	0.193	0.229			
Vert. Pt	0.016	0.028	0.044	0.063	0.086	0.112	0.142	0.175	0.212	0.253			
Throw	1 1 3	1 2 4	2 3 5	2 3 6	2 4 7	3 4 8	3 5 8	3 5 9	4 6 9	4 6 10			
NC	-	-	-	<15	17	22	26	29	32	36			
PSD	3 x 3 (W x L)	5" Inlet	CFM	45	60	75	90	105	120	135	150	165	180
			Ps	0.021	0.038	0.059	0.085	0.115	0.150	0.190	0.235	0.284	0.339
			Horiz. Pt	0.028	0.050	0.078	0.112	0.152	0.199	0.252	0.311	0.376	0.447
		Throw	0 1 4	1 2 5	1 2 6	2 4 7	2 4 8	3 5 9	4 5 11	4 6 11	4 6 12	5 7 12	
		NC	-	-	<15	19	24	28	31	34	36	39	
		CFM	45	60	75	90	105	120	135	150	165	180	
	Ps	0.021	0.038	0.059	0.085	0.115	0.150	0.190	0.235	0.284	0.339		
	Vert. Pt	0.028	0.050	0.078	0.112	0.152	0.199	0.252	0.311	0.376	0.447		
	Throw	0 1 4	1 2 5	1 2 6	2 4 7	2 4 8	3 5 10	4 5 11	4 6 12	4 7 12	5 7 13		
	NC	-	-	<15	19	24	28	31	34	36	39		
	6" Inlet	CFM	45	60	75	90	105	120	135	150	165	180	
			Ps	0.018	0.033	0.051	0.074	0.100	0.131	0.166	0.205	0.248	0.295
Horiz. Pt			0.022	0.039	0.060	0.087	0.118	0.154	0.195	0.241	0.292	0.347	
Throw		0 1 4	1 2 5	1 2 6	2 4 7	2 4 8	3 5 9	4 5 11	4 6 11	4 6 12	5 7 12		
NC		-	-	<15	19	24	28	31	34	36	39		
CFM		45	60	75	90	105	120	135	150	165	180		
Ps	0.018	0.033	0.051	0.074	0.100	0.131	0.166	0.205	0.248	0.295			
Vert. Pt	0.022	0.039	0.060	0.087	0.118	0.154	0.195	0.241	0.292	0.347			
Throw	0 1 4	1 2 5	1 2 6	2 4 7	2 4 8	3 5 10	4 5 11	4 6 12	4 7 12	5 7 13			
NC	-	-	<15	19	24	28	31	34	36	39			
1 x 4 2 x 4 4 x 4 (W x L)	5" Inlet	CFM	60	80	100	120	140	160	180	200	-	-	
			Ps	0.031	0.056	0.087	0.125	0.171	0.223	0.282	0.349	-	-
			Horiz. Pt	0.043	0.077	0.121	0.174	0.237	0.309	0.391	0.483	-	-
		Throw	1 2 3	1 2 4	2 3 5	2 3 6	2 4 7	3 4 8	3 5 9	3 5 10	-	-	
		NC	-	<15	20	25	29	33	37	41	-	-	
		CFM	60	80	100	120	140	160	180	200	-	-	
	Ps	0.031	0.056	0.087	0.125	0.171	0.223	0.282	0.349	-	-		
	Vert. Pt	0.043	0.077	0.121	0.174	0.237	0.309	0.391	0.483	-	-		
	Throw	0 1 2	0 1 4	1 1 6	1 2 6	1 3 7	2 4 7	2 5 8	3 6 8	-	-		
	NC	-	<15	20	25	29	33	37	41	-	-		
	6" Inlet	CFM	60	80	100	120	140	160	180	200	-	-	
			Ps	0.026	0.046	0.072	0.103	0.141	0.184	0.233	0.287	-	-
Horiz. Pt			0.032	0.056	0.088	0.127	0.172	0.225	0.285	0.352	-	-	
Throw		1 2 3	1 2 4	2 3 5	2 3 6	2 4 7	3 4 8	3 5 9	3 5 10	-	-		
NC		-	<15	20	25	29	33	37	41	-	-		
CFM		60	80	100	120	140	160	180	200	-	-		
Ps	0.026	0.046	0.072	0.103	0.141	0.184	0.233	0.287	-	-			
Vert. Pt	0.032	0.056	0.088	0.127	0.172	0.225	0.285	0.352	-	-			
Throw	0 1 2	0 1 4	1 1 6	1 2 6	1 3 7	2 4 7	2 5 8	3 6 8	-	-			
NC	-	<15	20	25	29	33	37	41	-	-			

## Performance Notes for Series LT:

All data are tested in accordance with ANSI/ASHRAE 70-1991

- NC based on Lw Re 10<sup>-12</sup> watts and a 10 dB room attenuation.
- Performance data is based on a regressed slot with air pattern deflectors supplied in the diffuser. Actual performance will vary depending on the light fixture and the configuration of the air pattern if supplied by the light fixture manufacturer.
- Total Pressure in inches W.G. and is the sum of velocity and static pressure.
- Throw values are at 150, 100 and 75 fpm terminal velocity or horizontal throw using isothermal air.

Performance data is supplied for selection purposes, and is based on a regressed slot with the pattern controller supplied in the diffuser. It should be noted that actual job performance will vary depending on the type of light fixture used, the configuration of the pattern controller if supplied by the light fixture manufacturer, and variances in the physical dimensions from one light fixture manufacturer to another.

## Series LT - Specifications

### Single Sided Supply - Light Troffer Diffuser - T-bar Lay-in - Insulated/Non Insulated/Model SS-LT(I)-6

Single sided supply light troffer diffusers shall be METALAIRES SS-LT-6 (non-insulated) or SSI-LT-6 (insulated). Light troffer diffusers shall be of the sizes as shown on the device schedule and shall be fabricated to fit the manufacturer and model of light fixture specified.

Diffuser shall be single sided with a side entrance inlet. Units shall be shipped fully assembled and include hold down tabs for positive alignment and locking the light troffer diffuser onto the slot of the light fixture.

Inlets shall be oval, centrally located, with a minimum depth of 2 1/8" for ease of duct connection. Light troffer diffusers shall be constructed of corrosion resistant galvanized steel.

Diffuser face shall be black.

Insulated diffusers shall be model SSI-LT-6. Internal insulation shall be 1/2" thick matte face. External insulation shall be 1/2" thick with a vapor barrier. Matening return should be model SSRI-LT-6, insulated or model SSR-LT-6, non insulated.

### Double Sided Supply - Side/Top Inlet - Light Troffer Diffuser - T-bar Lay-in - Insulated/Non Insulated/Model DS-LT(I)-6

Double sided supply light troffer diffusers shall be METALAIRES DS-LT-6 or DST-LT-6 (non-insulated) or DSI-LT-6 or DSTI-LT-6 (insulated). Light troffer diffusers shall be of the sizes as shown on the device schedule and shall be fabricated to fit the manufacturer and model of light fixture specified.

Diffusers shall be double sided and be available with either a top or side entrance inlet. Units shall be shipped fully assembled and include hold down tabs for positive alignment and locking the light troffer diffuser onto the slot of the light fixture.

Side inlets shall be oval; top inlets shall be round.

Inlets shall be centrally located, with a minimum depth of 2 1/8" for ease of duct connection. Light troffer diffusers shall be constructed of corrosion resistant galvanized steel.

Diffuser face shall be black.

Insulated diffusers shall be model DSI-LT-6 or DSTI-LT-6. Internal insulation shall be 1/2" thick matte face. External insulation shall be 1/2" thick with a vapor barrier.

# PSD - Plenum Slot Diffusers

8/2006

## Performance Specification

The manufacturer shall provide published performance data. Data shall be tested in accordance to ANSI/ASHRAE Standard 70-1991.

## Paint Specification

Process shall be anodic electrodeposition using an anodic acrylic paint. Units shall undergo pre-treatment including a pressurized spray stage using an alkaine cleaner and a de-ionized water rinse.

Film Properties shall meet or exceed the following standards:

Property	Test Method	Performance
Film thickness		.8-1.0 mils
Film Cure		320 F @ 20 min
Gloss – 60 deg.	ASTM D523-89	70-80%
Pencil Hardness	ASTM D3363-92A	HB-H
Crosshatch Adhesion	ASTM D3359-95	4B-5B
Direct Impact	ASTM D2794-93	100 in.lbs. Min
Reverse Impact	ASTM D2794-93	60 in.lbs. Min.
Salt Spray	ASTM B117-95	48-96 Hours
Humidity	ASTM D1735-92	500 Hours
Water Soak	ASTM D870-92	250 Hours

Plenum Slot Diffusers

PSD

## Series LT - Model Specification Guide

Plenum Slot Diffuser - Light Troffer Diffuser

Series LT - T-bar Lay-in

Model	Length	Inlet	Available Finishes
<b>Single Sided</b>		4"	Standard
<b>Supply</b> SS-LT-6 - Non Insulated SSI-LT-6 - Insulated	24" 36" 48"	5"	27 - All Black
		6"	
		7"	
<b>Return</b> SSR-LT-6 - Non Insulated SSRI-LT-6 - Insulated			
<b>Double Sided</b>			
<b>Side Inlet</b> DS-LT-6 - Non Insulated DSI-LT-6 - Insulated	12" x 48"		
	24" x 24"		
	24" x 48"		
<b>Top Inlet</b> DST-LT-6 - Non Insulated DSTI-LT-6 - Insulated			



# LEADING THE INDUSTRY IN PRODUCT LITERATURE

With the choice of our Pre-Flite Catalog, Quick Select Catalog, InfoSource Catalog, InfoSource CD and our web site, [www.metalaire.com](http://www.metalaire.com), you pick the format for product information that best suites your air distribution design needs.

## Pre-Flite - Product Overview Catalog

Our Pre-Flite catalog is a condensed reference guide containing the listing of our complete product offers for grilles, registers, diffusers, and air terminal units. This catalog can be used to help select the type of device, along with available border styles. The catalog includes photos of each model along with the features and model guide, a great tool when you are trying to select a device for your project.



## Quick Select Catalog - Air Distribution Selection Made Easy

The METALAIRES Quick Select Catalog is designed to save you time selecting air distribution equipment. This catalog is a compact version of our InfoSource Catalog and includes drawings and performance for our most popular products. The Quick Select Catalog is broken into product types with each section beginning with a model summary that includes features and benefits of our products. To obtain product information not included in the Quick Select Catalog, simply go to our web site at [www.metalaire.com](http://www.metalaire.com).



## InfoSource Catalog - Complete guide to Air Distribution Selection

The METALAIRES InfoSource Catalog is the leading product catalog in the industry. Included in this catalog are the complete product listings, drawings, product features and benefits, product performance data, specifications, and model specifications. This catalog is organized to make it quick and easy to find the information you are looking for.



## InfoSource CD

Our InfoSource CD has set the standard in the industry for air distribution product selection. This CD contains a complete library of all our catalogs and submittals along with our air terminal unit selection program.



Web Site: [www.metalaire.com](http://www.metalaire.com) <<http://www.metalaire.com/>>

METALAIRES leads the industry with a web site that contains all the product literature and performance data needed to design your air distribution system. Our web site includes all our submittals, catalogs, installation manuals, as well as as other valuable information to aid you in air distribution design.



**METALAIRES**  
EXPERIENCE AIR SUPERIORITY

ARCHITECTURAL  
DIFFUSERS

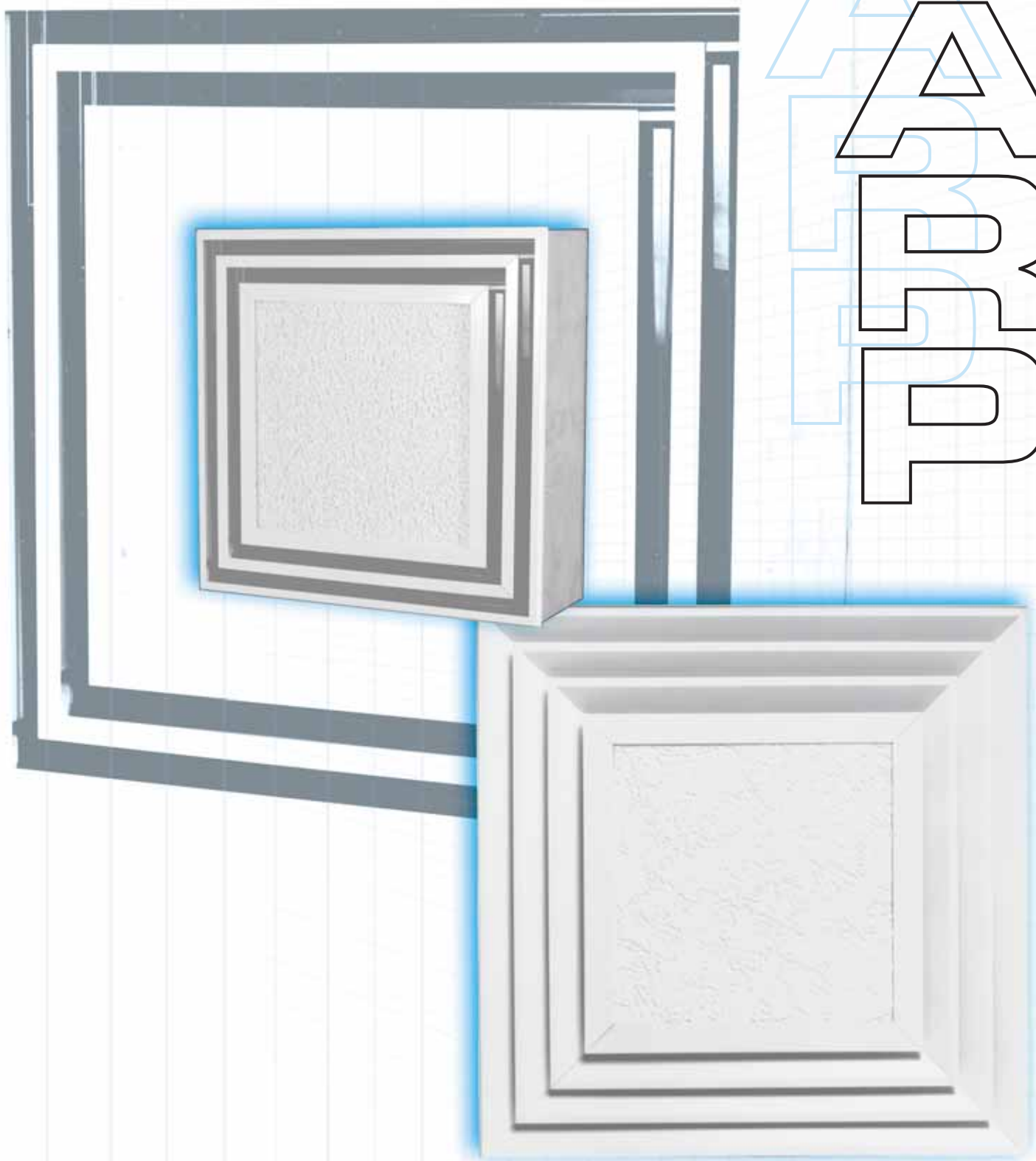

**ARCHITECTURAL  
DIFFUSERS**



**Model 5500DD**  
Pg. 242

## Louvered Face - Fixed Deflection - Aluminum - Series 5500DD

- ✦ Series 5500DD offers an architectural air diffuser designed to excel in both performance and aesthetic appeal
- ✦ The unique horizontal lip on all sides of the diffuser face provides a horizontal air pattern that is tight to the ceiling. This attribute makes the series 5500DD ideally suited for maximum occupant comfort, even in variable volume systems
- ✦ The series 5500DD is shipped fully assembled and is designed to allow the ceiling tile to be installed (by others) from the face without having to remove the plenum. This means the center tile can be installed after the diffuser has been installed in the ceiling
- ✦ The series 5500DD, available in both supply and return models, is offered in a wide variety of border styles and slot configurations, allowing for maximum design flexibility
- ✦ Supply unit constructed with extruded aluminum face and steel backpan. Return units include steel light shield/baffle
- ✦ Available with 1 to 4 slots
- ✦ The series 5500DD is an excellent choice for VAV applications

	Louvered Face			
	Supply		Return	
Insulated	5500DDI-6 T-bar Lay-in	5500DDI-8 Tegalur T-bar		
	5500DDI-9 24x24 Donn Finline			
Non-Insulated	5500DD-6 T-bar Lay-in	5500DD-8 Tegalur T-bar	5500DDR-6 T-bar Lay-in	5500DDR-8 Tegalur T-bar
	5500DD-9 24x24 Donn Finline		5500DDR-9 Fine Lline	

Architectural Rating Products



ARP



**Model 6600SQ**  
Pg. 248

## Modular Slot - Aluminum- Series 6600SQ

- ✦ The series 6600SQ provides outstanding operation flexibility. The supply units are shipped with pattern controllers that are individually adjustable from the face of the diffuser. This feature allows the direction of air flow to be adjusted a full 180°. The return is shipped without pattern controller to minimize sound and pressure drop
- ✦ The series 6600SQ is shipped fully assembled and is designed to allow the ceiling tile to be installed (by others) from the face without having to remove the plenum. This means the center tile can be installed after the diffuser has been installed in the ceiling
- ✦ The series 6600SQ, available in both supply and return models, is offered in a wide variety of border styles and slot configurations, allowing for maximum design flexibility
- ✦ Supply unit constructed with extruded aluminum face and pattern controllers, with a steel backpan. Return units include steel light shield/baffle
- ✦ Available with 1 to 4 slots
- ✦ The series 6600SQ is an excellent choice for VAV applications

	Modular Slot			
	Supply		Return	
Insulated	6600SQI-6 T-bar Lay-in	6600SQI-8 Tegalur T-bar		
	6600SQI-9 Donn Finline			
Non-Insulated	6600SQ-6 T-bar Lay-in	6600SQ-8 Tegalur T-bar	6600SQR-6 T-bar Lay-in	6600SQR-8 Tegalur T-bar
	6600SQ-9 Donn Finline		6600SQR-9 Donn Finline	



# LEADING THE INDUSTRY IN PRODUCT LITERATURE

With the choice of our Pre-Flite Catalog, Quick Select Catalog, InfoSource Catalog, InfoSource CD and our web site, [www.metalaire.com](http://www.metalaire.com), you pick the format for product information that best suits your air distribution design needs.

## Pre-Flite - Product Overview Catalog

The METALAIRES Pre-Flite catalog is a condensed reference guide containing concise listings of our entire product line including grilles, registers, diffusers, and air terminal units. This catalog can be used to help select the type of device, along with available border styles. The catalog includes photos of each model along with the features and model guide, a great tool when you are trying to select a device for your project.



## Quick Select Catalog - Air Distribution Selection Made Easy

The METALAIRES Quick Select Catalog is designed to save you time selecting air distribution equipment. This catalog is a compact version of our InfoSource Catalogs and includes drawings and performance for our most popular products. The Quick Select Catalog is broken into product types with each section beginning with a model summary that includes features and benefits of our products. To obtain product information not included in the Quick Select Catalog, simply go to our web site at [www.metalaire.com](http://www.metalaire.com).



## InfoSource Catalog Suite - Complete guide to Air Distribution Selection

The METALAIRES InfoSource Catalog suite is the leading product catalog in the industry. Included in these catalogs are the complete product listings, drawings, product features and benefits, product performance data, specifications, and model specifications. These catalogs are organized to make it quick and easy to find the information you are looking for.

### InfoSource Catalog Suite

- Ceiling Diffusers Catalog
- Grilles & Registers Catalog
- Air Terminal Unit Catalog
- Formations Catalog



## InfoSource CD

Our InfoSource CD has set the standard in the industry for air distribution product selection. This CD contains a complete library of all our catalogs and submittals along with our air terminal unit selection program.



## Web Site: [www.metalaire.com](http://www.metalaire.com)

METALAIRES leads the industry with a web site that contains all the product literature and performance data needed to design your air distribution system. Our web site includes all our submittals, catalogs, installation manuals, as well as as other valuable information to aid you in air distribution design.



**METALAIRES**  
EXPERIENCE AIRE SUPERIORITY.



## ↳ Louvered Face ↳ Series 5500DD ↳ Aluminum

### Product Details

- ✦ Series 5500DD offers an architectural air diffuser designed to excel in both performance and aesthetic appeal
- ✦ The unique horizontal lip on all sides of the diffuser face provides a horizontal air pattern that is tight to the ceiling. This attribute makes the series 5500DD ideally suited for maximum occupant comfort, even in variable volume systems
- ✦ The series 5500DD is shipped fully assembled and is designed to allow the ceiling tile to be installed (by others) from the face without having to remove the plenum. This means the center tile can be installed after the diffuser has been installed in the ceiling
- ✦ The series 5500DD, available in both supply and return models, is offered in a wide variety of border styles and slot configurations, allowing for maximum design flexibility
- ✦ Supply unit constructed with extruded aluminum face and steel backpan. Return units include steel light shield/baffle
- ✦ Available with 1 to 4 slots
- ✦ The series 5500DD is an excellent choice for VAV applications



**Model 5500DD-6 Shown**

Standard Finish: 01 White

Dimensions are in inches

**Supply - Non Insulated/Insulated - Fixed Louvered Face**  
**Aluminum - T-bar Lay-in**  
 Model 5500DD-6 - Non insulated  
 Model 5500DDI-6 - Insulated

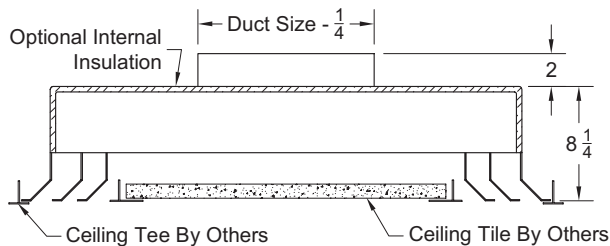

**Return - Non Insulated - Aluminum - Fixed Louvered Face**  
 Model 5500 DDR-6

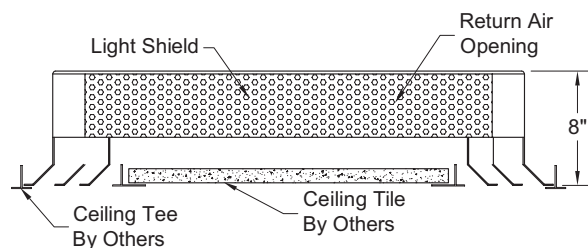

# ARP - Architecturally Rated Products

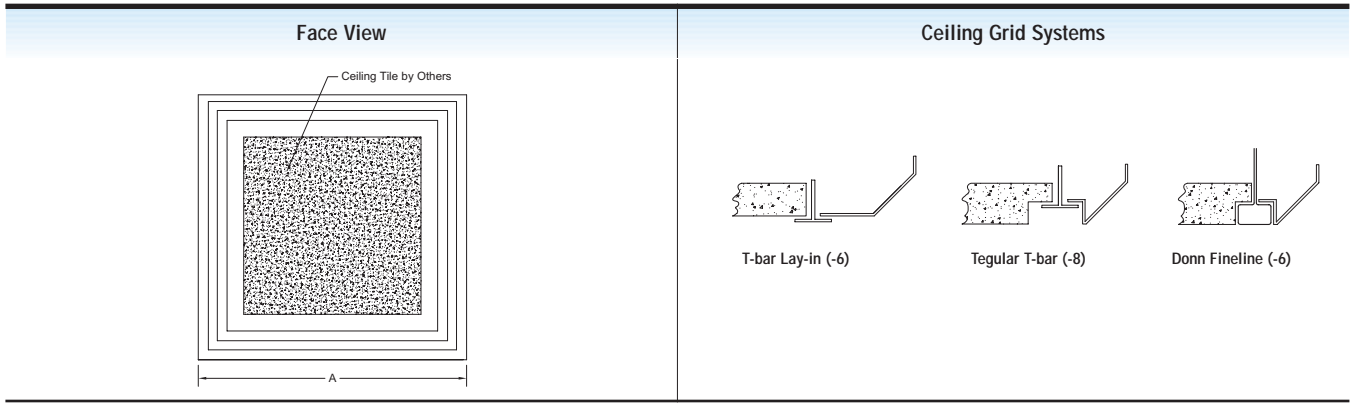

1. Available Finishes	2. Available Accessories	3. Construction Details
<p><b>Standard Finish:</b> 01 White w/black plenum</p> <p><b>Optional Finish (additional charge):</b> 28 Custom color</p>	<p>D3 - Opposed Blade Damper .....189</p> <p>G3 - Equalizing Grid .....190</p> <p>BDS - Butterfly Damper .....190</p> <p>RSD - Radial Shutter Damper .....189</p> <p>TBPF - T-bar Plaster Frame .....189</p>	<ul style="list-style-type: none"> <li>• Insulated units have 1/2" Tuffskin insulation</li> <li>• Center ceiling tile supplied by others, field installed.</li> <li>• Return units are non-ducted, with light shields</li> </ul>

Architectural Rating Products



ARP

# ARP - Architecturally Rated Products

8/2006

## Series 5500DD - Performance

Models 5500DD-6, 5500DDI-6/Supply

<b>1</b> slot Type 24" x 1" 8 Inch Inlet	<i>CFM</i>	50	100	150	200	250	300	350
	<i>Total Pressure</i>	0.01	0.03	0.07	0.13	0.20	0.30	0.40
	<i>Static Pressure</i>	0.007	0.024	0.058	0.109	0.168	0.254	0.337
	<i>NC</i>	<20	<20	22	28	33	38	41
	<i>Throw</i>	2-3-5	4-5-7	5-6-9	6-8-10	7-9-12	8-11-14	9-12-16
<b>2</b> slot Type 24" x 2" 8 Inch Inlet	<i>CFM</i>	100	150	200	250	300	350	400
	<i>Total Pressure</i>	0.02	0.05	0.08	0.12	0.18	0.24	0.31
	<i>Static Pressure</i>	0.014	0.038	0.059	0.088	0.134	0.177	0.227
	<i>NC</i>	<20	<20	22	28	33	38	41
	<i>Throw</i>	2-3-5	3-5-7	4-6-8	4-7-9	5-8-11	6-9-12	7-10-13
<b>3</b> slot Type 24" x 3" 8 Inch Inlet	<i>CFM</i>	150	200	250	300	350	400	450
	<i>Total Pressure</i>	0.03	0.06	0.09	0.13	0.18	0.23	0.30
	<i>Static Pressure</i>	0.018	0.039	0.058	0.084	0.117	0.147	0.194
	<i>NC</i>	<20	<20	25	30	34	38	41
	<i>Throw</i>	3-4-6	4-5-7	4-6-8	5-7-9	5-8-10	6-9-12	7-10-14
<b>4</b> slot Type 24" x 4" 8 Inch Inlet	<i>CFM</i>	200	250	300	350	400	450	500
	<i>Total Pressure</i>	0.05	0.08	0.11	0.16	0.20	0.26	0.32
	<i>Static Pressure</i>	0.029	0.048	0.064	0.097	0.117	0.154	0.195
	<i>NC</i>	<20	23	28	32	36	39	42
	<i>Throw</i>	3-4-9	3-5-7	4-6-8	5-7-10	5-8-11	6-9-12	6-10-13
<b>4</b> slot Type 24" x 4" 10 Inch Inlet	<i>CFM</i>	250	300	350	400	450	500	550
	<i>Total Pressure</i>	0.061	0.085	0.123	0.151	0.196	0.247	0.298
	<i>Static Pressure</i>	0.48	0.085	0.123	0.151	0.196	0.247	0.298
	<i>NC</i>	20	25	29	33	36	39	41
	<i>Throw</i>	3-5-7	4-6-8	5-7-10	5-8-11	6-9-12	6-10-13	7-10-14

Architectural Rating Products



ARP

## Series 5500DD - Performance

### Models 5500DDR-6/Return

<b>1</b> slot	<b>CFM</b>	100	125	165	200	225	275
	<b>NC</b>	<20	20	22	25	30	35
	<b>Negative</b>	0.02"	0.03"	0.06"	0.08"	0.10"	0.15"
<b>2</b> slot	<b>CFM</b>	155	190	250	310	345	425
	<b>NC</b>	<20	22	24	27	32	37
	<b>Negative</b>	0.02"	0.03"	0.06"	0.08"	0.10"	0.15"
<b>3</b> slot	<b>CFM</b>	225	275	360	450	505	620
	<b>NC</b>	21	24	25	29	34	38
	<b>Negative</b>	0.02"	0.03"	0.06"	0.08"	0.10"	0.15"
<b>4</b> slot	<b>CFM</b>	295	350	430	590	660	810
	<b>NC</b>	22	25	27	30	35	40
	<b>Negative</b>	0.02"	0.03"	0.06"	0.08"	0.10"	0.15"

Inlet Size	6"	8"	9"	10"	12"	14"	16"
Total Ft. <sup>2</sup>	0.196	0.349	0.441	0.545	0.785	1.07	1.40

<b>Neck Velocity (fpm)</b>	300	400	500	600	700	800	900	1000	1100	1200	1400	1600
<b>Velocity Pressure</b>	0.006	0.010	0.016	0.023	0.031	0.040	0.051	0.063	0.075	0.090	0.122	0.160

All data obtained in a manner as described in the ANSI/ASHRAE Standard 70-1991.

**Horizontal throw** - values are at terminal velocities of 150, 100 and 50 fpm respectively, using 4-way pattern.

**NC** - based on Lw Re 10-12 watts and minus a 10dB room absorption. Where no value is shown, NC is less than 20.

**Static pressure** - is for diffuser only.

**Total pressure** - includes plenum and inlet collar size listed and is the sum of velocity and static pressure.

To determine total pressure for other inlet sizes, divide the CFM by the square footage of the inlet size (chart below). The result is the duct velocity in feet per minute. From the velocity pressure chart, determine the velocity pressure and add it to the static pressure shown in the performance chart to determine the total pressure.

**Example:** determine TP for a four slot 6700SQ-50CD with a 9" inlet at 350 CFM.  $350 / 0.441 = 794$  fpm duct velocity.  $800$  fpm duct velocity =  $0.04 V_p + 0.045 S_p = 0.085 T.P.$  All values based on isothermal air. All pressures are in inches, W.G.



## Series 5500DD - Specification

### Supply Square and Rectangular Louvered Face - Aluminum/*Series 5500DD (DDI)*

<b>Insulated</b>	<b>Non-Insulated</b>
5500DDI-6 - T-bar Lay-in	5500DD-6 - T-bar Lay-in
5500DDI-9 - Donn Finline	5500DD-9 - Donn Finline

Air Outlets shall be model 5500DDI (insulated) or 5500DD (non-insulated) manufactured by METALAIRES. Units shall be square face ceiling supply diffusers and shall have a factory attached back. Back pan must be of sufficient height to allow center tile (by the ceiling system manufacturer) to be installed from the diffuser face without disassembling the face from the back pan. Devices without back pan attached to the diffuser face will not be allowed. The units shall be the size and quantity as outline in the plans and specifications.

Diffuser shall be one through four slots. The diffuser shall be designed to integrate with the ceiling type. It shall have horizontal deflection surfaces on the fixed pattern control blades which provide a horizontal ceiling pattern with a twenty degree cooling temperature differential at twenty percent of design volume.

### Return Square and Rectangular Louvered Face - Aluminum/*Series 5500 DDR*

<b>Non-Insulated</b>
5500 DDR-6 - T-bar Lay-in
5500 DDR-9 - Donn Finline

Air Inlets shall be model 5500DD manufactured by METALAIRES. Units shall be square face ceiling return or exhaust diffusers and shall have a factory attached light shield. Light shield must be of sufficient height to allow center tile (by the ceiling system manufacturer) to be installed from the diffuser face without disassembling the face from the back pan. Devices without light shield attached to the diffuser face will not be allowed. The units shall be the size and quantity as outline in the plans and specifications.

Diffuser shall be one through four slots. The diffuser shall be designed to integrate with the ceiling type. Face shall have fixed louvers designed to match the appearance of the supply unit.

### Round Neck Optional Dampers and Accessories

#### Butterfly Damper

METALAIRES model BDS aluminum round butterfly type dampers shall be provided. Damper shall consist of two butterfly style blades that can be adjusted from full open to full closed. Damper shall be adjusted with a screw driver slot that can be assessed through the face of the diffuser.

#### Radial Shutter Damper

METALAIRES model RSD steel round radial shutter damper shall be provided. Damper shall consist of gang operated radial blades that slide perpendicular to air flow direction. The damper shall be adjusted from full open to full closed. Damper shall be adjusted with a screw driver slot that can be assessed through the face of the diffuser.

#### Opposed Blade Damper

METALAIRES model D3 aluminum or SD3 Steel round opposed blade type dampers shall be provided. Damper shall consist of gang operated blades that can be adjusted from full open to full closed. Damper shall be adjusted with a screw driver slot that can be assessed through the face of the diffuser.

#### Equalizing Grid

METALAIRES model G3 aluminum round equalizing grid shall be provided. Equalizing grid shall consist of 1/2" x 1/2" x 1/2" aluminum cubed core mounting in an aluminum frame.

### Performance Specification

The manufacturer shall provide published performance data. Data shall be tested in accordance to ANSI/ASHRAE Standard 70-1991.

### Paint Specification

Process shall be anodic electrodeposition using an anodic acrylic paint. Units shall undergo pre-treatment including a pressurized spray stage using an alkaine cleaner and a de-ionized water rinse.

Film Properties shall meet or exceed the following standards:

Property	Test Method	Performance
Film thickness		.8-1.0 mils
Film Cure		320 F @ 20 min
Gloss – 60 deg.	ASTM D523-89	70-80%
Pencil Hardness	ASTM D3363-92A	HB-H
Crosshatch Adhesion	ASTM D3359-95	4B-5B
Direct Impact	ASTM D2794-93	100 in.lbs. Min
Reverse Impact	ASTM D2794-93	60 in.lbs. Min.
Salt Spray	ASTM B117-95	48-96 Hours
Humidity	ASTM D1735-92	500 Hours
Water Soak	ASTM D870-92	250 Hours



## Model Specification Guide

Supply - Fixed Louver Face Architectural Diffusers  
Aluminum - Series 5500DD

Model	Inlet	Number of Slots	Module	Available Finishes	Available Options	
5500DD-6 - T-bar Lay-in	6"	1	24" x 24"	<b>Standard</b>	D3	Radial Opposed Blade Damper - Aluminum
5500DDI-6 - T-bar Lay-in - Insulated	8"	2		01 -White Face w/Black Back Pan	SD3	Radial Opposed Blade Damper - Steel
5500DD-8 - Tegalur T-bar	10"	3		<b>Options</b>	G3	Equalizing Grid
5500DDI-8 - Tegalur T-bar - Insulated	12"	4		28 - Custom Color	BDS	Butterfly Damper
5500DD-9 - Donn Finline					RSD	Radial Shutter Damper
5500DDI-9 - Donn Finline - Insulated					TBPF	T-bar Plaster Frame

Return/Exhaust - Fixed Louver Face Architectural Diffuser  
Aluminum - Series 5500DD

Model	Number of Slots	Module	Available Finishes
5500DDR-6- T-bar Lay-in 5500DDR-8- Tegalur T-bar 5500DDR-9- Donn Finline	1	24" x 24"	<b>Standard</b>
	2		01 -White Face w/Black Back Pan
	3		<b>Options</b>
	4		28 - Custom Color



## ➔ Perforated Face ➔ Series 6600 SQ ➔ Aluminum

### Product Details

- ✦ The series 6600SQ provides outstanding operation flexibility. The supply units are shipped with pattern controllers that are individually adjustable from the face of the diffuser. This feature allows the direction of air flow to be adjusted a full 180°. The return is shipped without pattern controller to minimize sound and pressure drop
- ✦ The series 6600SQ is shipped fully assembled and is designed to allow the ceiling tile to be installed (by others) from the face without having to remove the plenum. This means the center tile can be installed after the diffuser has been installed in the ceiling
- ✦ The series 6600SQ, available in both supply and return models, is offered in a wide variety of border styles and slot configurations, allowing for maximum design flexibility
- ✦ Supply unit constructed with extruded aluminum face and pattern controllers, with a steel backpan. Return units include steel light shield/baffle
- ✦ Available with 1 to 4 slots
- ✦ The series 6600SQ is an excellent choice for VAV applications



**Model 6600 SQ-6 Shown**

Standard Finish: 01 White

Dimensions are in inches

#### Supply - Non Insulated (Insulated) - Aluminum

Model 6600 SQ(I)-6 - T-bar Lay-in  
 Model 6600 SQ(I)-8 - Tegalur T-bar  
 Model 6600 SQ(I)-9 - Donn Finline

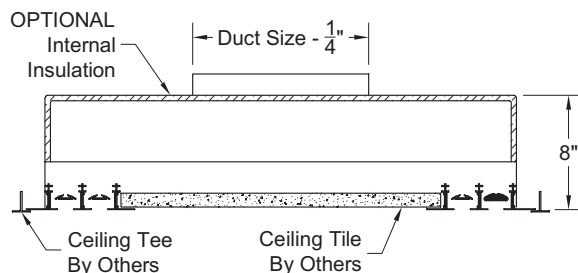

#### Return - Non Insulated - Aluminum

Model 6600 SQR-6 - T-bar Lay-in  
 Model 6600 SQR-8 - Tegalur T-bar  
 Model 6600 SQR-9 - Donn Finline

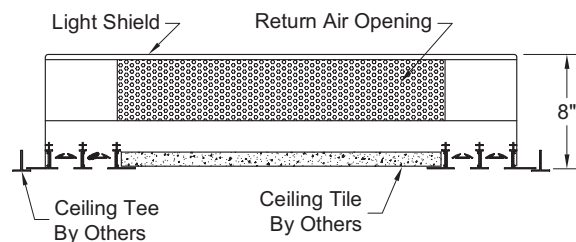

# ARP - Architecturally Rated Products

Face View

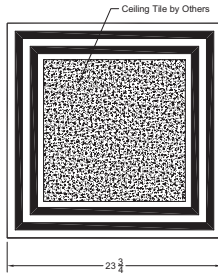

Model	1 Slot		2 Slot		3 Slot		4 Slot	
	S	A	S	A	S	A	S	A
6650SQ-6	1/2"	2 3/4"	1/2"	4"	1/2"	5 1/4"	1/2"	6 1/2"
6675SQ-6	3/4"	3"	3/4"	4 1/2"	3/4"	6"	3/4"	7 1/2"
6610SQ-6	1"	3 1/4"	1"	5"	1"	6 3/4"	1"	8 1/2"

Ceiling Grid System

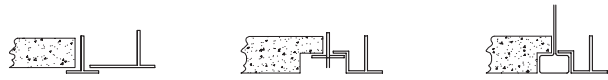

T-bar Lay-in (-6)  
(6600SQ-6)

Tegular T-bar (-8)  
(6600SQ-8)

Donn Finline (-6)  
(6600SQ-9)

1. Available Finishes	2. Available Accessories	3. Construction Details
<p><b>Standard Finish:</b> 20 White w/black pattern controllers</p> <p><b>Optional Finish (additional charge):</b> 28 Custom color</p>	<p>D3 - Opposed Blade Damper - Aluminum . . . .336</p> <p>SD3 - Opposed Blade Damper - Steel . . . . .336</p> <p>G3 - Equalizing Grid . . . . .337</p> <p>BDS - Butterfly Damper . . . . .335</p>	<ul style="list-style-type: none"> <li>Insulated units have 1/2" Tuffskin insulation</li> <li>Center ceiling tile supplied by others, field installed.</li> <li>Return units are non-ducted, with light shields</li> <li>Three slot widths available: 6650 (1/2"), 6675 (3/4"), and 6610 (1")</li> </ul>

Architectural Rating Products



ARP



## Series 6600SQ - Performance

### 1/2" Slot Width

<b>1</b> slot Type 24" x 24" 6 Inch Inlet	<b>CFM</b>	50	100	150	175	200	225
	<b>Horizontal</b>	4-6-8	6-10-15	8-13-19	12-17-22	15-20-29	18-24-35
	<b>Total Pressure</b>	0.028	0.102	0.227	0.302	0.370	0.42
	<b>Static Pressure</b>	0.023	0.086	0.19	0.251	0.305	0.42
	<b>NC</b>	-	27	35	41	48	52
<b>2</b> slot Type 24" x 24" 8 Inch Inlet	<b>CFM</b>	75	125	150	200	250	275
	<b>Horizontal</b>	3-5-7	4-7-10	5-8-12	7-10-15	9-3-19	11-18-22
	<b>Total Pressure</b>	0.034	0.059	0.122	0.021	0.312	0.39
	<b>Static Pressure</b>	0.03	0.051	0.11	0.18	0.28	0.35
	<b>NC</b>	-	-	24	29	38	45
<b>3</b> slot Type 24" x 24" 8 Inch Inlet	<b>CFM</b>	100	150	200	225	250	300
	<b>Horizontal</b>	2-4-5	3-6-7	5-8-11	6-9-13	7-10-15	9-12-18
	<b>Total Pressure</b>	0.042	0.088	0.146	0.187	0.222	0.312
	<b>Static Pressure</b>	0.036	0.076	0.125	0.16	0.19	0.265
	<b>NC</b>	-	-	21	27	35	43
<b>4</b> slot Type 24" x 24" 10 Inch Inlet	<b>CFM</b>	150	200	250	275	300	350
	<b>Horizontal</b>	3-5-6	5-7-8	7-10-12	8-11-14	9-13-17	11-15-21
	<b>Total Pressure</b>	0.061	0.103	0.153	0.191	0.209	0.282
	<b>Static Pressure</b>	0.056	0.094	0.14	0.175	0.19	0.255
	<b>NC</b>	-	22	28	32	37	40

### 3/4" Slot Width

<b>1</b> slot Type 24" x 24" 6 Inch Inlet	<b>CFM</b>	50	100	150	200	250	300
	<b>Horizontal</b>	2-3-5	35-9	4-8-13	6-10-16	8-12-18	10-15-20
	<b>Total Pressure</b>	0.013	0.039	0.083	0.145	0.219	0.319
	<b>Static Pressure</b>	0.011	0.033	0.071	0.125	0.187	0.272
	<b>NC</b>	-	-	20	28	32	39
<b>2</b> slot Type 24" x 24" 10 Inch Inlet	<b>CFM</b>	100	150	200	250	300	350
	<b>Horizontal</b>	2-4-7	3-6-10	5-8-13	6-10-16	7-12-18	8-14-20
	<b>Total Pressure</b>	0.015	0.033	0.068	0.087	0.124	0.172
	<b>Static Pressure</b>	0.013	0.026	0.049	0.074	0.105	0.145
	<b>NC</b>	-	-	20	24	26	31
<b>3</b> slot Type 24" x 24" 10 Inch Inlet	<b>CFM</b>	150	200	250	300	350	400
	<b>Horizontal</b>	3-4-9	4-5-12	5-7-15	6-9-17	7-11-19	8-13-22
	<b>Total Pressure</b>	0.023	0.040	0.051	0.078	0.117	0.149
	<b>Static Pressure</b>	0.018	0.031	0.048	0.059	0.090	0.115
	<b>NC</b>	-	-	22	25	28	32
<b>4</b> slot Type 24" x 24" 12 Inch Inlet	<b>CFM</b>	200	250	300	350	400	450
	<b>Horizontal</b>	3-4-8	4-5-11	6-9-15	7-10-18	8-11-20	8-13-22
	<b>Total Pressure</b>	0.025	0.038	0.064	0.075	0.092	0.117
	<b>Static Pressure</b>	0.021	0.031	0.044	0.062	0.075	0.094
	<b>NC</b>	-	-	-	22	25	28

Inlet Size	6"	8"	9"	10"	12"	14"	16"
Total Ft. <sup>2</sup>	0.196	0.349	0.441	0.545	0.785	1.07	1.40

Neck Velocity (fpm)	300	400	500	600	700	800	900	1000	1100	1200	1400	1600
Velocity Pressure	0.006	0.010	0.016	0.023	0.031	0.040	0.051	0.063	0.075	0.090	0.122	0.160

All data obtained in a manner as described in the ANSI/ASHRAE Standard 70-1991.

**Horizontal throw** - values are at terminal velocities of 150, 100 and 50 fpm respectively, using 4-way pattern.

**NC** - based on Lw Re 10-12 watts and minus a 10 dB room absorption. Where no value is shown, NC is less than 20.

**Static pressure** - is for diffuser only.

**Total pressure** - includes plenum and inlet collar size listed and is the sum of velocity and static pressure.

To determine total pressure for other inlet sizes, divide the CFM by the square footage of the inlet size (chart below). The result is the duct velocity in feet per minute. From the velocity pressure chart, determine the velocity pressure and add it to the static pressure shown in the performance chart to determine the total pressure.

**Example:** determine TP for a four slot 6600SQ-50CD with a 9" inlet at 350 CFM.  $350 / 0.441 = 794$  fpm duct velocity.  $800$  fpm duct velocity =  $0.04 V_p + 0.045 S_p = 0.085 T.P.$  All values based on isothermal air. All pressures are in inches, W/G.

## Series 6600SQ - Performance

### 1" Slot Width

<b>1</b> slot Type 24" x 24" 8 Inch Inlet	<i>CFM</i>	100	150	200	250	300	350
	<i>Horizontal</i>	3-5-10	5-7-13	6-9-15	8-12-18	9-14-20	11-16-22
	<i>Total Pressure</i>	0.023	0.046	0.080	0.122	0.172	0.228
	<i>Static Pressure</i>	0.017	0.034	0.059	0.090	0.125	0.165
	<i>NC</i>	–	–	27	30	38	44
<b>2</b> slot Type 24" x 24" 10 Inch Inlet	<i>CFM</i>	150	200	250	330	350	400
	<i>Horizontal</i>	2-4-10	3-6-12	5-8-15	7-10-17	8-13-21	8-15-24
	<i>Total Pressure</i>	0.030	0.050	0.074	0.103	0.137	0.169
	<i>Static Pressure</i>	0.025	0.041	0.061	0.084	0.110	0.135
	<i>NC</i>	–	–	22	28	35	39
<b>3</b> slot Type 24" x 24" 12 Inch Inlet	<i>CFM</i>	200	250	300	350	400	450
	<i>Horizontal</i>	4-5-10	5-7-13	6-8-16	7-9-19	8-11-21	9-13-23
	<i>Total Pressure</i>	0.028	0.042	0.055	0.074	0.090	0.117
	<i>Static Pressure</i>	0.023	0.035	0.046	0.061	0.074	0.094
	<i>NC</i>	–	–	20	25	29	34
<b>4</b> slot Type 24" x 24" 12 Inch Inlet	<i>CFM</i>	250	300	350	400	450	500
	<i>Horizontal</i>	4-5-10	5-7-13	6-8-15	7-10-19	7-11-20	8-12-22
	<i>Total Pressure</i>	0.034	0.048	0.059	0.071	0.091	0.107
	<i>Static Pressure</i>	0.027	0.038	0.045	0.55	0.68	0.081
	<i>NC</i>	–	20	23	27	30	33

<i>Inlet Size</i>	6"	8"	9"	10"	12"	14"	16"
<i>Total Ft. <sup>2</sup></i>	0.196	0.349	0.441	0.545	0.785	1.07	1.40

<i>Neck Velocity (fpm)</i>	300	400	500	600	700	800	900	1000	1100	1200	1400	1600
<i>Velocity Pressure</i>	0.006	0.010	0.016	0.023	0.031	0.040	0.051	0.063	0.075	0.090	0.122	0.160

All data obtained in a manner as described in the ANSI/ASHRAE Standard 70-1991.

**Horizontal throw** - values are at terminal velocities of 150, 100 and 50 fpm respectively, using 4-way pattern.

**NC** - based on Lw Re 10-12 watts and minus a 10 dB room absorption. Where no value is shown, NC is less than 20.

**Static pressure** - is for diffuser only.

**Total pressure** - includes plenum and inlet collar size listed and is the sum of velocity and static pressure.

To determine total pressure for other inlet sizes, divide the CFM by the square footage of the inlet size (chart below). The result is the duct velocity in feet per minute. From the velocity pressure chart, determine the velocity pressure and add it to the static pressure shown in the performance chart to determine the total pressure.

**Example:** determine TP for a four slot 6600SQ-50CD with a 9" inlet at 350 CFM.  $350 / 0.441 = 794$  fpm duct velocity.  $800$  fpm duct velocity =  $0.04 V_p + 0.045 S_p = 0.085 T.P.$  All values based on isothermal air. All pressures are in inches, W.G.



## Series 6600 SQ - Specification

### Supply Square and Rectangular Louvered Face - Aluminum/Series 6600SQ(I)

**Insulated**

6600SQI-6 - T-bar Lay-in  
6600SQI-9 - Donn Fineline

**Non-insulated**

6600SQ-6 - T-bar Lay-in  
6600SQ-9 - Donn Fineline

Air Outlets shall be model 6600SQI (insulated) or 6600SQ (non-insulated) manufactured by METALAIRES. Units shall be square face ceiling supply diffusers and shall have a factory attached back. Back pan must be of sufficient height to allow center tile (by the ceiling system manufacturer) to be installed from the diffuser face without disassembling the face from the back pan. Devices without back pan attached to the diffuser face will not be allowed. The units shall be the size and quantity as outline in the plans and specifications.

Outlet pattern controllers shall be curved, aerodynamically shaped, capable of adjustment from the face of the diffuser. The pattern controllers shall allow adjustment from vertical to horizontal patterns as well as damper the volume through the face of the diffuser. In the horizontal position, pattern controllers shall be field adjustable to obtain a 1 way, 2 way opposite, 2 way corner, 3 way, and 4 way directional air patterns. Pattern controllers shall be aluminum construction. Steel pattern controllers are not acceptable.

Diffuser shall be one through four slots. Units shall be available with 1/2", 3/4" or 1" slot widths. The diffuser shall be designed to integrate with the ceiling type.

### Return Square and Rectangular Louvered Face - Aluminum/Series 6600SQR

**Non-insulated**

6600SQR-6 - T-bar Lay-in  
6600SQR-9 - Donn Fineline

Air Inlets shall be model 6600SQR manufactured by METALAIRES. Units shall be square face ceiling return or exhaust diffusers and shall have a factory attached light shield. Light shield must be of sufficient height to allow center tile (by the ceiling system manufacturer) to be installed from the diffuser face without disassembling the face from the back pan. Devices without light shield attached to the diffuser face will not be allowed. The units shall be the size and quantity as outline in the plans and specifications.

Diffuser shall be one through four slots. Units shall be available with 1/2", 3/4" or 1" slot widths. The diffuser shall be designed to integrate with the ceiling type. Face shall be designed to match the appearance of the supply unit.

### Round Neck Optional Dampers and Accessories

**Butterfly Damper**

METALAIRES model BDS aluminum round butterfly type dampers shall be provided. Damper shall consist of two butterfly style blades that can be adjusted from full open to full closed. Damper shall be adjusted with a screw driver slot that can be assessed through the face of the diffuser.

**Radial Shutter Damper**

METALAIRES model RSD steel round radial shutter damper shall be provided. Damper shall consist of gang operated radial blades that slide perpendicular to air flow direction. The damper shall be adjusted from full open to full closed. Damper shall be adjusted with a screw driver slot that can be assessed through the face of the diffuser.

**Opposed Blade Damper**

METALAIRES model D3 aluminum or SD3 steel round opposed blade type dampers shall be provided. Damper shall consist of gang operated blades that can be adjusted from full open to full closed. Damper shall be adjusted with a screw driver slot that can be assessed through the face of the diffuser.

**Equalizing Grid**

METALAIRES model G3 aluminum round equalizing grid shall be provided. Equalizing grid shall consist of 1/2" x 1/2" x 1/2" aluminum cubed core mounting in an aluminum frame.

### Performance Specification

The manufacturer shall provide published performance data. Data shall be tested in accordance to ANSI/ASHRAE Standard 70-1991.

### Paint Specification

Process shall be anodic electrodeposition using an anodic acrylic paint. Units shall undergo pre-treatment including a pressurized spray stage using an alkaine cleaner and a de-ionized water rinse.

Film Properties shall meet or exceed the following standards:

Property	Test Method	Performance
Film thickness		.8-1.0 mils
Film Cure		320 F @ 20 min
Gloss – 60 deg.	ASTM D523-89	70-80%
Pencil Hardness	ASTM D3363-92A	HB-H
Crosshatch Adhesion	ASTM D3359-95	4B-5B
Direct Impact	ASTM D2794-93	100 in.lbs. Min
Reverse Impact	ASTM D2794-93	60 in.lbs. Min.
Salt Spray	ASTM B117-95	48-96 Hours
Humidity	ASTM D1735-92	500 Hours
Water Soak	ASTM D870-92	250 Hours



## Model Specification Guide

### Supply - Modular Slot Architectural Diffusers Aluminum - Series 6600SQ

Model	Slot Width	Inlet	Number of Slots	Module	Available Finishes	Available Options
6600SQ-6 - T-bar Lay-in 6600SQI-6 - T-bar Lay-in - Insulated 6600SQ-8 - Tegular T-bar 6600SQI-8 - Tegular T-bar - Insulated 6600SQ-9 - Donn Finline 6600SQI-9 - Donn Finline - Insulated	1/2"	6"	1	24" x 24"	Standard	D3 Radial Opposed Blade Damper - aluminum
	3/4"	8"	2		20 - White Face w/Black Pattern Controllers	
	1"	10"	3		Optional	SD3 Radial Opposed Blade Damper - steel
		12"	4		28 - Custom Color	G3 Equalizing Grid
						BDS Butterfly Damper
						RSD Radial Shutter Damper
						TBPF T-bar Plaster Frame

### Return/Exhaust - Modular Slot Architectural Diffuser Aluminum - Series 6600SQ

Model	Slot Width	Inlet	Number of Slots	Module	Available Finishes
6600SQR-6 T-bar Lay-in 6600SQR-8 Tegular T-bar 6600SQR-9 Donn Finline	1/2"	6"	1	24" x 24"	Standard
	3/4"	8"	2		01 - White Face
	1"	10"	3		Optional
		12"	4		28 - Custom Color



# LEADING THE INDUSTRY IN PRODUCT LITERATURE

With the choice of our Pre-Flite Catalog, Quick Select Catalog, InfoSource Catalog, InfoSource CD and our web site, [www.metalaire.com](http://www.metalaire.com), you pick the format for product information that best suits your air distribution design needs.

## Pre-Flite - Product Overview Catalog

The METALAIRES Pre-Flite catalog is a condensed reference guide containing concise listings of our entire product line including grilles, registers, diffusers, and air terminal units. This catalog can be used to help select the type of device, along with available border styles. The catalog includes photos of each model along with the features and model guide, a great tool when you are trying to select a device for your project.



## Quick Select Catalog - Air Distribution Selection Made Easy

The METALAIRES Quick Select Catalog is designed to save you time selecting air distribution equipment. This catalog is a compact version of our InfoSource Catalogs and includes drawings and performance for our most popular products. The Quick Select Catalog is broken into product types with each section beginning with a model summary that includes features and benefits of our products. To obtain product information not included in the Quick Select Catalog, simply go to our web site at [www.metalaire.com](http://www.metalaire.com).



## InfoSource Catalog Suite - Complete guide to Air Distribution Selection

The METALAIRES InfoSource Catalog suite is the leading product catalog in the industry. Included in these catalogs are the complete product listings, drawings, product features and benefits, product performance data, specifications, and model specifications. These catalogs are organized to make it quick and easy to find the information you are looking for.

### InfoSource Catalog Suite

- Ceiling Diffusers Catalog
- Grilles & Registers Catalog
- Air Terminal Unit Catalog
- Formations Catalog



## InfoSource CD

Our InfoSource CD has set the standard in the industry for air distribution product selection. This CD contains a complete library of all our catalogs and submittals along with our air terminal unit selection program.



## Web Site: [www.metalaire.com](http://www.metalaire.com)

METALAIRES leads the industry with a web site that contains all the product literature and performance data needed to design your air distribution system. Our web site includes all our submittals, catalogs, installation manuals, as well as other valuable information to aid you in air distribution design.







DIFFUSERS

**ENVIRONMENTAL/  
HOSPITAL DIFFUSERS**



**Model HPL-CL**  
Pg. 260

## Environmental/Hospital Diffusers - Laminar Flow - Series HPL-CL

- ✦ The HPL laminar flow diffusers are engineered for supply air distribution in critical environments such as hospital operating rooms and clean rooms. The diffusers are engineered to supply a low velocity vertical "piston" of conditioned air
- ✦ The HPL-CL laminar is easy to clean and sterilize. The face and core assembly can be removed from the face for cleaning. With the face and core assembly removed, the interior of the backpan and inlet collar are free of obstructions and easy to access
- ✦ The diffuser is available with a choice of three free areas for the perforated face: 23%, 40% and 51% maximizing the range of capacities for the HPL. The HPL is also available in aluminum or stainless steel construction

	Laminar Flow		
	Surface Mount	T-bar Lay-in	Special 1 1/2" T-bar Lay-in
Aluminum	HPL-CL-AL-1	HPL-CL-AL-6	HPL-CL-AL-6M
Stainless Steel	HPL-CL-SS-1	HPL-CL-SS-6	HPL-CL-SS-6M
SS Face/Aluminum Backpan	HPL-CL-SA-1	HPL-CL-SA-6	HPL-CL-SA-6M



**Model HPL-HA**  
Pg. 266

## Environmental/Hospital Diffusers - Laminar Flow - w/HEPA Filter Cell - Series HPL-HA

- ✦ When the application calls for the HEPA filters to be located in the supply diffuser, the HPL-HA is an excellent choice. The series HPL-HA laminar flow diffusers are engineered for supply air distribution in critical environments such as hospital operating rooms and clean rooms. The diffusers are engineered to supply a low velocity vertical "piston" of conditioned air
- ✦ The series HPL-HA design includes a HEPA filter cell accessible from the face of the diffuser. The face and core assembly can be removed from the face for cleaning. This feature allows the filters to be removed and replaced from the diffuser face
- ✦ The diffuser is available with a choice of three free areas for the perforated face: 23%, 40% and 51% maximizing the range of capacities for the HPL. The HPL is also available in aluminum or stainless steel construction
- ✦ Optional HEPA filters are available

	Laminar Flow		
	Surface Mount	T-bar Lay-in	Special 1 1/2" T-bar Lay-in
Aluminum	HPL-HA-AL-1	HPL-HA-AL-6	HPL-CL-HA-6M
Stainless Steel	HPL-HA-SS-1	HPL-HA-SS-6	HPL-CL-HA-6M
SS Face/Aluminum Backpan	HPL-HA-SA-1	HPL-HA-SA-6	HPL-CL-HA-6M



**Model HPL-PR**  
Pg. 272

## Environmental/Hospital Diffusers - Laminar Flow - Patient Isolation Applications - Series HPL-PR

- ✦ The series HPL-PR is specifically engineered to improve patient comfort in critical health care applications such as isolation rooms and trauma centers. The unique design provides a "tent" of conditioned air around the patient
- ✦ The unique design of the HPL-PR provides filtered air to protect the patient and at the same time minimize the air velocities that impact the patient. This device provides a high level of comfort
- ✦ Series HPL-PR includes a HEPA filter section. Optional HEPA filters are available. HPL-PR configuration minimizes induction, distributing low velocity air with minimum aspiration
- ✦ Unit is aluminum construction and is available for Surface Mount and T-bar Lay-in applications, and is also available for special 1 1/2" wide T-bar Lay-in applications

	Laminar Flow - Patient Isolation Applications		
	Surface Mount	T-bar Lay-in	Special 1 1/2" T-bar Lay-in
Aluminum	HPL-PR-AL-1	HPL-PR-AL-6	HPL-PR-AL-6M
Stainless Steel	HPL-PR-SS-1	HPL-PR-SS-6	HPL-PR-SS-6M
SS Face/Aluminum Backpan	HPL-PR-SA-1	HPL-PR-SA-6	





**Model HRD-CL**  
Pg. 278

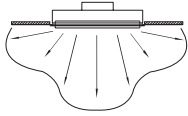

## Environmental/Hospital Diffusers - Radial Discharge Pattern - Removable Face - Series HRD-CL

- ★ The HRD-CL radial discharge pattern diffusers are engineered for supply air distribution in critical environments such as chemistry labs and clean rooms. The diffusers are engineered to supply a low velocity of conditioned air in a radial pattern from the ceiling
- ★ The HRD-CL radial discharge pattern diffusers are easy to clean and sterilize. The face and core assembly can be removed from the face for cleaning. With the face and core assembly removed, the interior of the backpan and inlet collar are free of obstructions and easy to access
- ★ The diffuser is available in stainless steel or heavy aluminum construction. Units available in 90° or 180° throw

	Radial Discharge		
	Flush Mount	T-bar Lay-in	Special 1 1/2" T-bar Lay-in
Aluminum	HRD-CL-AL-1	HRD-CL-AL-6	HRD-CL-AL-6M
Stainless Steel	HRD-CL-SS-1	HRD-CL-SS-6	HRD-CL-SS-6M
SS Face/Aluminum Backpan	HRD-CL-SA-1	HRD-CL-SA-6	HRD-CL-SA-6M



**Model HRD-HA**  
Pg. 284

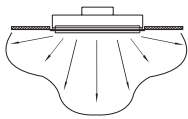

## Environmental/Hospital Diffusers - Radial Discharge Pattern - Removable Face w/HEPA Filter Series HRD-HA

- ★ The series HRD-HA radial discharge pattern diffusers includes a HEPA filter section and are engineered for supply air distribution in critical environments such as chemistry labs and clean rooms. The diffusers are engineered to supply a low velocity of conditioned air in a radial pattern from the ceiling
- ★ The series HRD-HA design includes a HEPA filter cell accessible from the face of the diffuser. The face and core assembly can be removed from the face for cleaning. This feature allows the filters to be removed and replaced from the diffuser face. Optional HEPA filters are available
- ★ The HRD-HA Radial Discharge Pattern Diffusers are easy to clean and sterilize. The face and core assembly can be removed from the face for cleaning. With the face and core assembly removed, the interior of the backpan and inlet collar are free of obstructions and easy to access
- ★ The diffuser is available in stainless steel or heavy aluminum construction. Units available in 90° or 180° throw
- ★ Optional HEPA Filters are available

	Radial Discharge - w/HEPA Filter Cell		
	Flush Mount	T-bar Lay-in	Special 1 1/2" T-bar Lay-in
Aluminum	HRD-HA-AL-1	HRD-HA-AL-6	HRD-HA-AL-6M
Stainless Steel	HRD-HA-SS-1	HRD-HA-SS-6	HRD-HA-SS-6M
SS Face/Aluminum Backpan	HRD-HA-SA-1	HRD-HA-SA-6	HRD-HA-SA-6M







**Model Periflow**  
Pg. 290

## Environmental/Hospital Diffusers - Laminar Flow - Operating Room Systems - Series Periflow

- ⊛ The Periflow operating room air distribution system provides control over particulate matter within the operating room environment
- ⊛ The system has been tested in accordance with the guidelines set forth by the Committee on Operating Room Environments of the American College of Surgeons as published in the January 1976 Bulletin and meets Class 1 Microbiological Air Cleanliness guidelines. The system provides the highest standard of air cleanliness for patients undergoing minor procedures or surgeries as critical as organ transplants
- ⊛ The system is in either stainless steel or heavy aluminum construction to ensure long-term durability and resistance to strong germicidal solutions. In addition, each system is custom designed and precisely fabricated to accommodate the specialized medical, mechanical, and electrical considerations of today's operating room environments
- ⊛ By its compact yet efficient design, the Periflow system allows the designer the flexibility to properly provide for all the various components competing for space above the operating room ceiling

<b>Flush Mount</b>
<b>Periflow</b> Laminar Flow Panels w/Perimeter Air Curtain

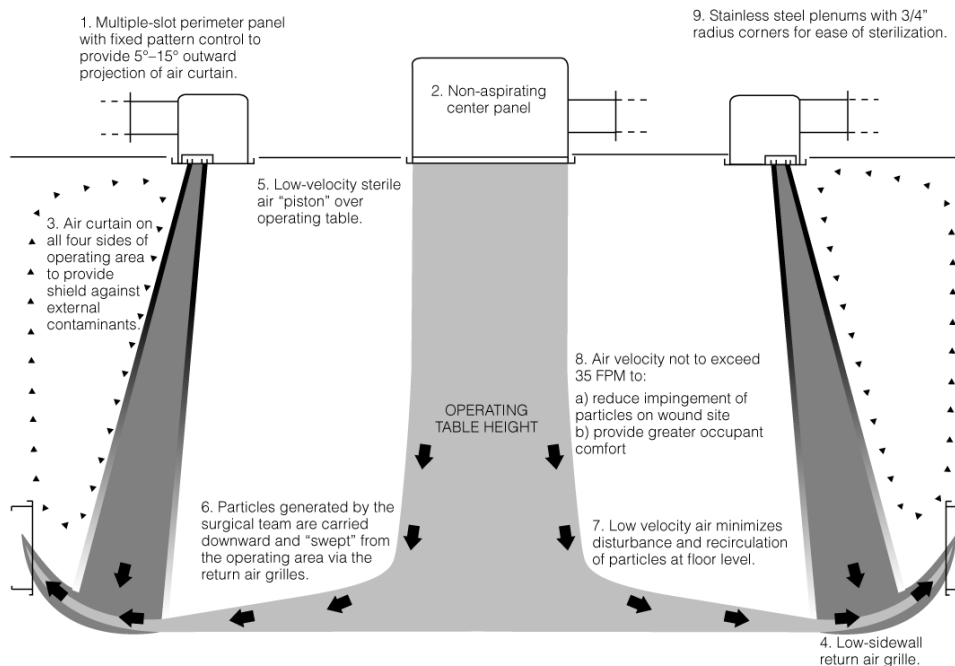

# LEADING THE INDUSTRY IN PRODUCT LITERATURE

With the choice of our Pre-Flite Catalog, Quick Select Catalog, InfoSource Catalog, InfoSource CD and our web site, [www.metalaire.com](http://www.metalaire.com), you pick the format for product information that best suits your air distribution design needs.

## Pre-Flite - Product Overview Catalog

The METALAIRES Pre-Flite catalog is a condensed reference guide containing concise listings of our entire product line including grilles, registers, diffusers, and air terminal units. This catalog can be used to help select the type of device, along with available border styles. The catalog includes photos of each model along with the features and model guide, a great tool when you are trying to select a device for your project.



## Quick Select Catalog - Air Distribution Selection Made Easy

The METALAIRES Quick Select Catalog is designed to save you time selecting air distribution equipment. This catalog is a compact version of our InfoSource Catalogs and includes drawings and performance for our most popular products. The Quick Select Catalog is broken into product types with each section beginning with a model summary that includes features and benefits of our products. To obtain product information not included in the Quick Select Catalog, simply go to our web site at [www.metalaire.com](http://www.metalaire.com).



## InfoSource Catalog Suite - Complete guide to Air Distribution Selection

The METALAIRES InfoSource Catalog suite is the leading product catalog in the industry. Included in these catalogs are the complete product listings, drawings, product features and benefits, product performance data, specifications, and model specifications. These catalogs are organized to make it quick and easy to find the information you are looking for.

### InfoSource Catalog Suite

- Ceiling Diffusers Catalog
- Grilles & Registers Catalog
- Air Terminal Unit Catalog
- Formations Catalog



## InfoSource CD

Our InfoSource CD has set the standard in the industry for air distribution product selection. This CD contains a complete library of all our catalogs and submittals along with our air terminal unit selection program.



## Web Site: [www.metalaire.com](http://www.metalaire.com)

METALAIRES leads the industry with a web site that contains all the product literature and performance data needed to design your air distribution system. Our web site includes all our submittals, catalogs, installation manuals, as well as as other valuable information to aid you in air distribution design.



**METALAIRES**  
EXPERIENCE AIRE SUPERIORITY.

## Environmental/Hospital Diffusers → Laminar Flow → Series HPL-CL

### Product Details

- ✦ The HPL laminar flow diffusers are engineered for supply air distribution in critical environments such as hospital operating rooms and clean rooms. The diffusers are engineered to supply a low velocity vertical "piston" of conditioned air
- ✦ The HPL-CL laminar is easy to clean and sterilize. The face and core assembly can be removed from the face for cleaning. With the face and core assembly removed, the interior of the backpan and inlet collar are free of obstructions and easy to access
- ✦ The diffuser is available with a choice of three free areas for the perforated face: 23%, 40% and 51% maximizing the range of capacities for the HPL. The HPL is also available in aluminum or stainless steel construction

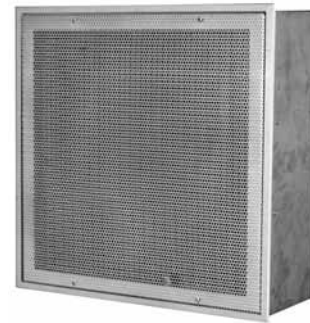

**Model HPL-CL Shown**  
Standard Finish: 01 White

Environmental/Hospital Diffusers



EHD

### Aluminum Face & Backpan

Dimensions are in inches

Hospital Diffuser - Laminar Flow  
Aluminum Face & Backpan  
Model HPL-CL-AL

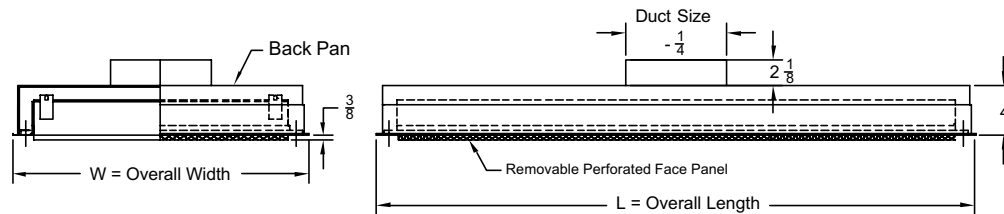

Hospital Diffuser - Laminar Flow  
Surface Mount - Aluminum Face & Backpan  
Model HPL-CL-AL-1

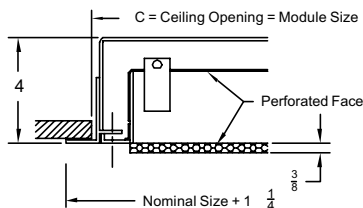

Hospital Diffuser - Laminar Flow  
Standard T-bar Lay-in - Aluminum Face & Backpan  
Model HPL-CL-AL-6

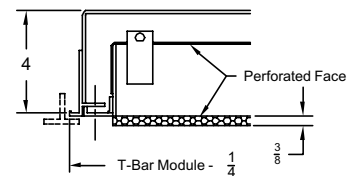

Hospital Diffuser - Laminar Flow  
Special 1 1/2" T-bar Lay-in - Aluminum Face & Backpan  
Model HPL-CL-AL-6M

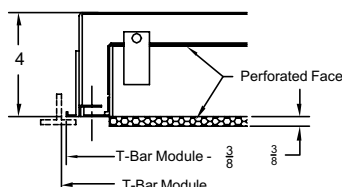

Nominal Size	Frame 1		Frame 6		Frame 6M		
	C	L	W	L	W	L	W
24 x 24	24 x 24	25 1/4	25 1/4	23 3/4	23 3/4	23 3/4	23 3/4
24 x 48	24 x 48	49 1/4	25 1/4	47 3/4	23 3/4	47 3/4	23 3/4

# 8/2006 EHD - Environmental / Hospital Diffusers

## Stainless Steel Face & Aluminum Backpan

Hospital Diffuser - Laminar Flow  
Stainless Steel Face & Aluminum Backpan  
Model HPL-CL-SA

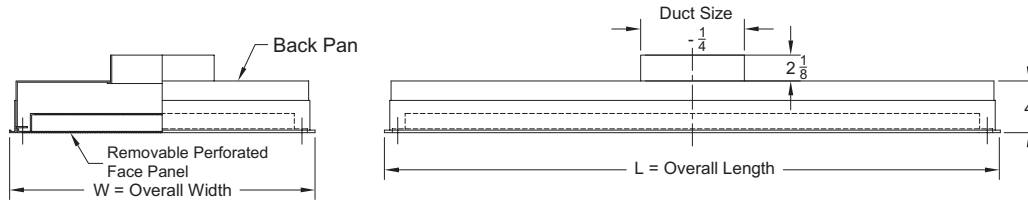

Hospital Diffuser - Laminar Flow  
Surface Mount - Stainless Steel Face & Aluminum Backpan  
Model HPL-CL-SA-1

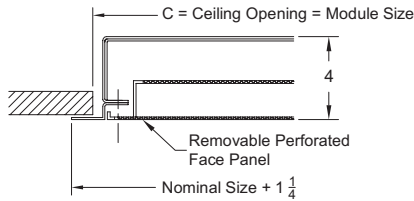

Hospital Diffuser - Laminar Flow  
Standard T-bar Lay-in - Stainless Steel Face & Aluminum Backpan  
Model HPL-CL-SA-6

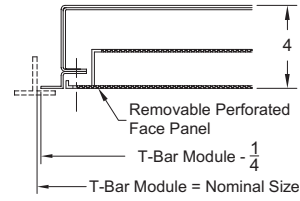

Hospital Diffuser - Laminar Flow  
Special 1 1/2" T-bar Lay-in - Stainless Steel Face & Aluminum Backpan  
Model HPL-CL-SA-6M

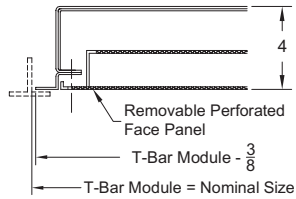

Nominal Size	Frame 1			Frame 6		Frame 6M	
	C	L	W	L	W	L	W
12 x 36	12 x 36	37 1/4	13 1/4	35 3/4	11 3/4	25 5/8	11 5/8
12 x 48	12 x 48	49 1/4	13 1/4	47 3/4	11 3/4	47 5/8	11 5/8
24 x 24	24 x 24	25 1/4	25 1/4	23 3/4	23 3/4	23 5/8	23 5/8
24 x 36	24 x 36	37 1/4	25 1/4	35 3/4	23 3/4	35 5/8	23 5/8
24 x 48	24 x 48	49 1/4	25 1/4	47 3/4	23 3/4	47 5/8	23 5/8

Environmental/Hospital Diffusers

EHD

## Stainless Steel Face & Backpan

Hospital Diffuser - Laminar Flow  
Stainless Steel Face & Backpan  
Model HPL-CL-SS

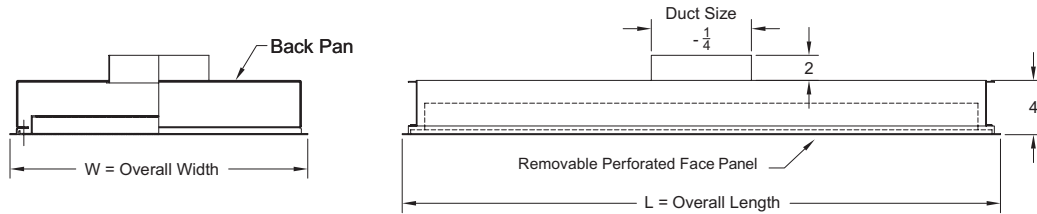

Environmental/Hospital Diffusers

Hospital Diffuser - Laminar Flow  
Surface Mount - Stainless Steel Face & Backpan  
Model HPL-CL-SS-1

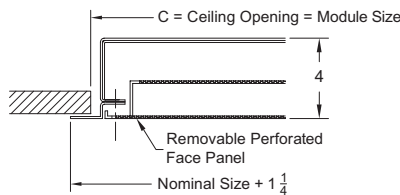

Hospital Diffuser - Laminar Flow  
Standard T-bar Lay-in - Stainless Steel Face & Backpan  
Model HPL-CL-SS-6

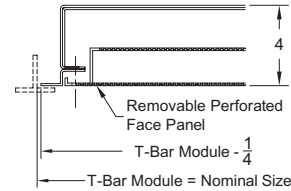

Hospital Diffuser - Laminar Flow  
Special 1 1/2" T-bar Lay-in - Stainless Steel Face & Backpan  
Model HPL-CL-SS-6M

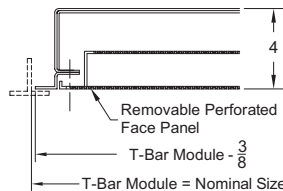

Nominal Size	Frame 1			Frame 6		Frame 6M	
	C	L	W	L	W	L	W
24 x 24	24 x 24	25 1/4	25 1/8	23 3/4	23 3/4	23 5/8	23 5/8
24 x 48	24 x 48	49 1/4	25 1/8	47 3/4	23 3/4	47 5/8	23 5/8

EHD

### Notes for Models HPL-CL-AL-1, HPL-CL-AL-6, HPL-CL-AL-6M

1. Available Finishes	2. Available Accessories	3. Construction Details
<b>Standard Finish:</b> 08 White epoxy powder coat	D3 - Aluminum Radial Opposed Blade Damper SD3 - Steel Radial Opposed Blade Damper RSD - Radial Shutter Damper CD - Cable Damper	<ul style="list-style-type: none"> <li>Perforated faces are shipped with 2 safety cables</li> <li>23%, 40%, 51% perforated face</li> <li>Round neck sizes available: 6, 8, 10, 12 &amp; 14</li> </ul>

### Notes for Models HPL-CL-SA-1, HPL-CL-SA-6, HPL-CL-SA-6M

1. Available Finishes	2. Available Accessories	3. Construction Details
<b>Standard Finish:</b> 23 #3 Scratch	D3 - Aluminum Radial Opposed Blade Damper SD3 - Steel Radial Opposed Blade Damper RSD - Radial Shutter Damper CD - Cable Damper	<ul style="list-style-type: none"> <li>Perforated faces are shipped with 2 safety cables</li> <li>23%, 40%, 51% perforated face</li> <li>Round neck sizes available: 6, 8, 10, 12 &amp; 14</li> </ul>

### Notes for Models HPL-CL-SS-1, HPL-CL-SS-6, HPL-CL-SS-6M

1. Available Finishes	2. Available Accessories	3. Construction Details
<b>Standard Finish:</b> 23 #3 Scratch	D3 - Aluminum Radial Opposed Blade Damper SD3 - Steel Radial Opposed Blade Damper RSD - Radial Shutter Damper CD - Cable Damper	<ul style="list-style-type: none"> <li>Perforated faces are shipped with 2 safety cables</li> <li>23%, 40%, 51% perforated face</li> <li>Round neck sizes available: 6, 8, 10, 12 &amp; 14</li> </ul>

## Series HPL-CL - Performance

Models HPL-CL-AL-1, HPL-CL-AL-6, HPL-CL-AL-6M, HPL-CL-SA-1, HPL-CL-SA-6, HPL-CL-SA-6M,  
HPL-CL-SS-1, HPL-CL-SS-6, HPL-CL-SS-6M

CFM Per SQ. Foot	HPL-CL 23% Face Free Area		HPL-CL 34% Face Free Area		HPL-CL 51% Face Free Area	
	<i>Ps</i>	<i>NC</i>	<i>Ps</i>	<i>NC</i>	<i>Ps</i>	<i>NC</i>
20	0.010	<15	0.005	<15	0.004	<15
30	0.021	<15	0.011	<15	0.010	<15
40	0.038	18	0.020	<15	0.017	<15
50	0.060	21	0.031	21	0.027	18
60	0.086	29	0.045	25	0.038	22
70	0.117	35	0.061	31	0.052	24
80	0.152	38	0.080	34	0.068	30
90	0.193	40	0.101	39	0.086	35
100	-	-	-	-	0.107	39

### Performance Notes for Series HPL-CL:

All data are tested in accordance with ANSI/ASHRAE 70-1991

### Definition of Units:

- Ps* - is static pressure loss through the diffuser and does not include velocity pressure
- NC* - is based on Lw Re 10<sup>-12</sup> watts, includes 10dB room attenuation
- NC* - is based on maximum inlet velocity of 500 fpm
- NC* - is for single diffuser only

### Multiple (adjacent): Panel Correction Factors

Total Sq. Footage	0.193	40	0.101	39	0.086	35
NC Correction	-	-	-	-	0.107	39

### Velocity Profile: Average Velocity

	CFM Per Square Foot of Panel							
	10	20	30	40	50	60	70	80
Single Panel	20	35	50	65	70	80	90	100
Mult. Panels (1)	20	35	50	70	80	90	100	110
Mult. Panels (2)	25	40	60	80	100	110	120	130

### Performance Notes:

Average velocity is in feet per minute and is based on readings 6 feet below panels using a 15° F temperature differential (cooling).

- Multiple panels:** (1) Average velocity for adjacent panels totaling 15 to 30 square feet.  
(2) Average velocity for adjacent panels totaling 30 plus square feet.

## Series HPL-CL - Specifications

### Aluminum Construction

- Model HPL-CL-AL-1 – *Surface Mount*
- Model HPL-CL-AL-6 – *Standard T-bar Lay-in*
- Model HPL-CL-AL-6M – *Special 1 1/2" T-bar Lay-in*

### Stainless Steel Construction

- Model HPL-CL-SS-1 – *Surface Mount*
- Model HPL-CL-SS-6 – *Standard T-bar Lay-in*
- Model HPL-CL-SS-6M – *Special 1 1/2" T-bar Lay-in*

### Stainless Steel Face/Aluminum Backpan

- Model HPL-CL-SA-1 – *Surface Mount*
- Model HPL-CL-SA-6 – *Standard T-bar Lay-in*
- Model HPL-CL-SA-6M – *Special 1 1/2" T-bar Lay-in*

Air outlets shall be model HPL-CL-AL (aluminum) or HPL-CL-SS (stainless steel) or HPL-CL-SA (stainless steel face/aluminum backpan) manufactured by METALAIRE. Diffuser shall include an upper and lower pressure chamber and shall generate a low velocity, vertical piston of discharge air.

Diffuser shall be constructed of a one-piece perforated face and core assembly that is removable from the backpan with 1/4" turn fasteners accessible from the face. Face and core assemblies mounted with internal spring clips or other mechanical fastening devices are not acceptable. Units shall include stainless steel safety chains attaching the face assembly to the backpan.

Core and face assembly shall be removable to allow sanitizing in an autoclave and allow access to the backpan for cleaning. With the core assembly removed, the inside of the backpan must be completely accessible for cleaning. Units with permanently fixed dampers, baffles or deflectors mounted in the backpan are not acceptable. Face shall be flush with the ceiling surface.

#### **Perforated face shall have a**

- 51% free area with 3/16" holes on 1/4" staggered centers.
- 40% free area with 1/8" holes on 3/16" staggered centers.
- 23% free area with 1/16" holes on 1/8" staggered centers.

Units shall have round inlets. Units shall be designed to integrate into the specified ceiling system. The units shall be the size and quantity as outline in the plans and specifications.

### Performance Specification

The manufacturer shall provide published performance data. Data shall be tested in accordance to ANSI/ASHRAE Standard 70-1991.

### Finish Specification

**Aluminum Face Diffusers:** Units shall be painted with a powder coat, baked on epoxy.

**Stainless Steel Face Diffusers:** # 3 Scratch Finish



## Series HPL-CL - Model Specification Guide

### Series HPL-CL - Laminar Flow Hospital Diffusers

Model	Inlet	Module	Free Area	Available Finishes	Available Options	
<b>Aluminum Face &amp; Backpan</b>	6"	24" x 12"	51%	08 - White epoxy (aluminum face)	D3	Radial Opposed Blade Damper - aluminum
HPL-CL-AL-1 - Surface Mount	8"	36" x 12"	40%	23 - #3 Scratch (stainless steel face)	SD3	Radial Opposed Blade Damper - steel
HPL-CL-AL-6 - T-bar Lay-in	9"	48" x 12"	23%			
HPL-CL-AL-6M - Special 1 1/2" T-bar Lay-in	10"	60" x 12"				
<b>Stainless Steel Face &amp; Backpan</b>	12"	72" x 12"				
HPL-CL-SS-1 - Surface Mount	14"	24" x 24"				
HPL-CL-SS-6 - T-bar Lay-in		36" x 24"				
HPL-CL-SS-6M - Special 1 1/2" T-bar Lay-in		48" x 24"				
		60" x 24"				
<b>Stainless Steel Face &amp; Aluminum Backpan</b>		72" x 24"				
HPL-CL-SA-1 - Surface Mount		48" x 36"				
HPL-CL-SA-6 - T-bar Lay-in						
HPL-CL-SA-6M - Special 1 1/2" T-bar Lay-in						





## ➔ Laminar Flow ➔ w/HEPA Filter Cell ➔ Series HPL-HA

### Product Details

- ⊛ When the application calls for the HEPA filters to be located in the supply diffuser, the HPL-HA is an excellent choice. The series HPL-HA laminar flow diffusers are engineered for supply air distribution in critical environments such as hospital operating rooms and clean rooms. The diffusers are engineered to supply a low velocity vertical "piston" of conditioned air
- ⊛ The series HPL-HA design includes a HEPA filter cell accessible from the face of the diffuser. The face and core assembly can be removed from the face for cleaning. This feature allows the filters to be removed and replaced from the diffuser face
- ⊛ The diffuser is available with a choice of three free areas for the perforated face: 23%, 40% and 51% maximizing the range of capacities for the HPL. The HPL is also available in aluminum or stainless steel construction
- ⊛ Optional HEPA filters are available



**Model HPL-HA Shown**

Standard Finish: 01 White

### Aluminum Face & Backpan

Dimensions are in inches

Hospital Diffuser - Laminar Flow - With HEPA Filter Cell  
Aluminum Face & Backpan  
Model HPL-HA-AL

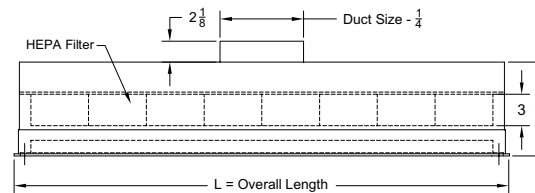
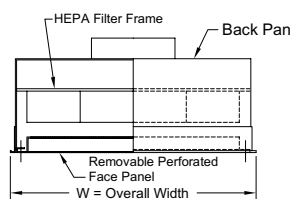

Hospital Diffuser - Laminar Flow - With HEPA Filter Cell  
Surface Mount - Aluminum Face & Backpan  
Model HPL-HA-AL-1

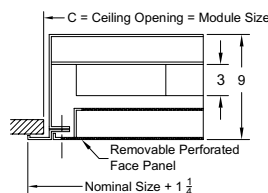

Hospital Diffuser - Laminar Flow - With HEPA Filter Cell  
Standard T-bar Lay-in - Aluminum Face & Backpan  
Model HPL-HA-AL-6

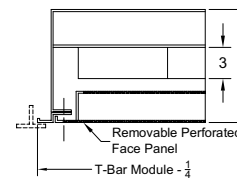

Hospital Diffuser - Laminar Flow - With HEPA Filter Cell  
Special 1 1/2" T-bar Lay-in - Aluminum Face & Backpan  
Model HPL-HA-AL-6M

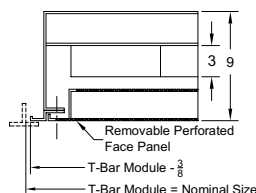

Nominal Size	Frame 1			Frame 6		Frame 6M	
	C	L	W	L	W	L	W
24 x 24	24 x 24	25 1/4	25 1/4	23 3/4	23 3/4	23 5/8	23 5/8
24 x 48	24 x 48	49 1/4	25 1/4	47 3/4	23 3/4	47 5/8	23 5/8

**Stainless Steel Face & Aluminum Backpan**

Hospital Diffuser - Laminar Flow - With HEPA Filter Cell  
 Stainless Steel Face & Aluminum Backpan  
 Model HPL-HA-SA

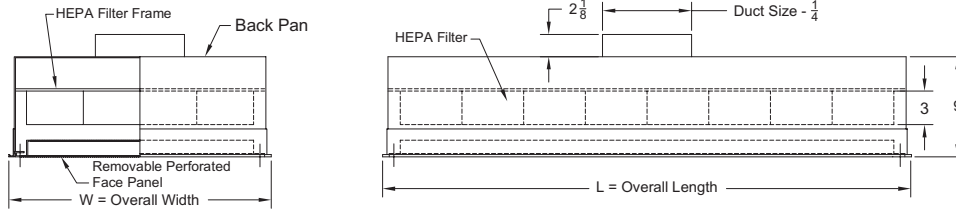

Hospital Diffuser - Laminar Flow - With HEPA Filter Cell  
 Surface Mount - Stainless Steel Face & Aluminum Backpan  
 Model HPL-HA-SA-1

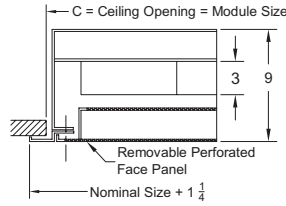

Hospital Diffuser - Laminar Flow - With HEPA Filter Cell  
 Standard T-bar Lay-in - Stainless Steel Face & Aluminum Backpan  
 Model HPL-HA-SA-6

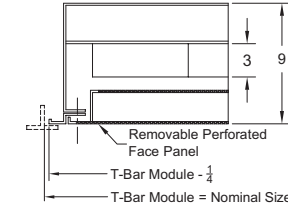

Hospital Diffuser - Laminar Flow - With HEPA Filter Cell  
 Special 1 1/2" T-bar Lay-in - Stainless Steel Face & Aluminum Backpan  
 Model HPL-HA-SA-6M

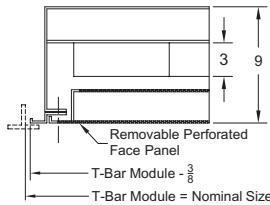

Nominal Size	Frame 1			Frame 6		Frame 6M	
	C	L	W	L	W	L	W
24 x 24	24 x 24	25 1/4	25 1/4	23 3/4	23 3/4	23 5/8	23 5/8
24 x 48	24 x 48	49 1/4	25 1/4	47 3/4	23 3/4	47 5/8	23 5/8

## Stainless Steel Face & Backpan

Hospital Diffuser - Laminar Flow - With HEPA Filter Cell  
Stainless Steel Face & Backpan  
Model HPL-HA-SS

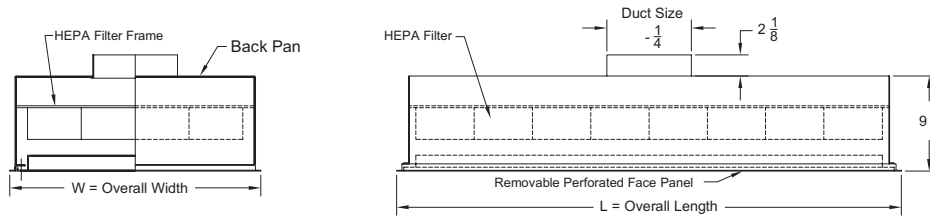

Hospital Diffuser - Laminar Flow - With HEPA Filter Cell  
Surface Mount - Stainless Steel Face & Backpan  
Model HPL-HA-SS-1

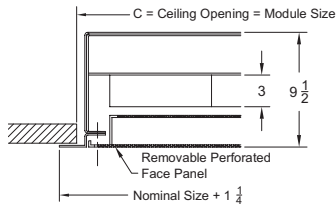

Hospital Diffuser - Laminar Flow - With HEPA Filter Cell  
Standard T-bar Lay-in - Stainless Steel Face & Backpan  
Model HPL-HA-SS-6

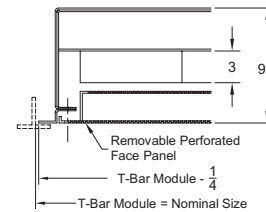

Hospital Diffuser - Laminar Flow - With HEPA Filter Cell  
Special 1 1/2" T-bar Lay-in - Stainless Steel Face & Aluminum Backpan  
Model HPL-HA-SS-6M

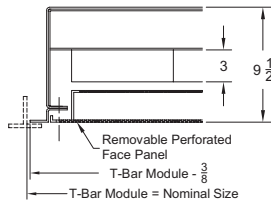

Nominal Size	Frame 1			Frame 6		Frame 6M	
	C	L	W	L	W	L	W
24 x 24	24 x 24	25 1/4	25 1/4	23 3/4	23 5/8	23 3/4	23 5/8
24 x 48	24 x 48	49 1/4	25 1/4	47 3/4	23 5/8	47 3/4	23 5/8

### Notes for Models HPL-HA-AL-1, HPL-HA-AL-6, HPL-HA-AL-6M

1. Available Finishes	2. Available Accessories	3. Available Options	4. Construction Details
Standard Finish: 08 White epoxy powder coat	CD - Cable Damper	HEPA Filter TP Test Port	<ul style="list-style-type: none"> <li>Perforated faces are shipped with 2 safety cables</li> <li>23%, 40%, 51% perforated face</li> <li>Round neck sizes available: 6, 8, 10, 12 &amp; 14</li> </ul>

### Notes for Models HPL-HA-SA-1, HPL-HA-SA-6, HPL-HA-SA-6M

1. Available Finishes	2. Available Accessories	3. Available Options	4. Construction Details
Standard Finish: 23 #3 scratch	CD - Cable Damper	HEPA Filter TP Test Port	<ul style="list-style-type: none"> <li>Perforated faces are shipped with 2 safety cables</li> <li>23%, 40%, 51% perforated face</li> <li>Round neck sizes available: 6, 8, 10, 12 &amp; 14</li> </ul>

### Notes for Models HPL-HA-SS-1, HPL-HA-SS-6, HPL-HA-SS-6M

1. Available Finishes	2. Available Accessories	3. Available Options	4. Construction Details
Standard Finish: 23 #3 scratch	CD - Cable Damper	HEPA Filter TP Test Port	<ul style="list-style-type: none"> <li>Perforated faces are shipped with 2 safety cables</li> <li>23%, 40%, 51% perforated face</li> <li>Round neck sizes available: 6, 8, 10, 12 &amp; 14</li> </ul>

Environmental/Hospital Diffusers

EHD

## Series HPL-HA - Performance

### HPL-HA Performance Data Without HEPA Filter

CFM Per SQ. Foot	HPL-CL 23% Face Free Area		HPL-CL 34% Face Free Area		HPL-CL 51% Face Free Area	
	Ps	NC	Ps	NC	Ps	NC
20	0.010	<15	0.005	<15	0.004	<15
30	0.021	<15	0.011	<15	0.010	<15
40	0.038	18	0.020	<15	0.017	<15
50	0.060	21	0.031	21	0.027	18
60	0.086	29	0.045	25	0.038	22
70	0.117	35	0.061	31	0.052	24
80	0.152	38	0.080	34	0.068	30
90	0.193	40	0.101	39	0.086	35
100	-	-	-	-	0.107	39

### HPL-HA Performance Data With 3" HEPA Filter

CFM Per SQ. Foot	HPL-CL 23% Face Free Area		HPL-CL 34% Face Free Area		HPL-CL 51% Face Free Area	
	Ps	NC	Ps	NC	Ps	NC
20	0.150	20	0.140	<20	0.130	<20
30	0.240	24	0.230	24	0.210	23
40	0.340	29	0.320	27	0.300	26
50	0.450	32	0.430	32	0.400	32
60	0.545	36	0.540	35	0.480	34
70	0.656	40	0.650	39	0.580	39
80	-	-	0.740	42	0.690	42
90	-	-	-	-	0.800	44
100	-	-	-	-	-	-

### Performance Notes for Series HPL-HA:

All data are tested in accordance with ANSI/ASHRAE 70-1991

### Definition of Units:

- Ps - is static pressure loss through the diffuser and does not include velocity pressure
- NC - is based on Lw Re 10<sup>-12</sup> watts, includes 10 dB room attenuation and a maximum inlet velocity of 500 fpm
- NC - is for single diffuser only
- HEPA - filter is a 3" deep filter, with an efficiency of 99.97% on D-3 micron particles

## Series HPL-HA - Specifications

### Aluminum Construction

- Model HPL-HA-AL-1 – *Surface Mount*
- Model HPL-HA-AL-6 – *Standard T-bar Lay-in*
- Model HPL-HA-AL-6M – *Special 1 1/2" T-bar Lay-in*

### Stainless Steel Construction

- Model HPL-HA-SS-1 – *Surface Mount*
- Model HPL-HA-SS-6 – *Standard T-bar Lay-in*
- Model HPL-HA-SS-6M – *Special 1 1/2" T-bar Lay-in*

### Stainless Steel Face/Aluminum Backpan

- Model HPL-HA-SA-1 – *Surface Mount*
- Model HPL-HA-SA-6 – *Standard T-bar Lay-in*
- Model HPL-HA-SA-6M – *Special 1 1/2" T-bar Lay-in*

Air outlets shall be model HPL-HA-AL (aluminum) or HPL-HA-SS (stainless steel) or HPL-HA-SA (stainless steel face/aluminum backpan) manufactured by METALAIRE. Diffuser shall include an upper and lower pressure chamber and shall generate a low velocity, vertical piston of discharge air. Unit shall also include an internal filter section to allow the installation and removal of a HEPA filter. Unit shall accept 3" beadpleat HEPA with filter held in place using a trapeze hanger system.

Diffuser shall be constructed of a one-piece perforated face and core assembly that is removable from the backpan with 1/4" turn fasteners accessible from the face. Face and core assemblies mounted with internal spring Clips or other mechanical fastening devices are not acceptable. Units shall include stainless steel safety chains attaching the face assembly to the backpan.

**Optional:** A factory installed 3" thick, 99.99% efficient filter on .30 microns shall be provided by the diffuser manufacturer.

Core and face assembly shall be removable to allow sanitizing in an autoclave and allow access to the backpan for cleaning. With the core assembly removed, the inside of the backpan must be completely accessible for cleaning. Units with permanently fixed dampers, baffles or deflectors mounted in the backpan are not acceptable. Face shall be flush with the ceiling surface.

#### **Perforated face shall have a**

- 51% free area with 3/16" holes on 1/4" staggered centers.
- 40% free area with 1/8" holes on 3/16" staggered centers.
- 23% free area with 1/16" holes on 1/8" staggered centers.

Units shall have round inlets. Units shall be designed to integrate into the specified ceiling system. The units shall be the size and quantity as outline in the plans and specifications.

### Performance Specification

The manufacturer shall provide published performance data. Data shall be tested in accordance to ANSI/ASHRAE Standard 70-1991.

### Finish Specification

**Aluminum Face Diffusers:** Units shall be painted with a powder coat, baked on epoxy.

**Stainless Steel Face Diffusers:** # 3 Scratch Finish



## Series HPL-HA - Model Specification Guide

### Series HPL-CL - Laminar Flow Hospital Diffusers

Model	Inlet	Module	Free Area	Available Finishes	Available Options	
<b>Aluminum Face &amp; Backpan</b>	6"	24" x 12"	51%	08 - White epoxy (aluminum face)	D3	Radial Opposed Blade Damper - aluminum
HPL-HA-AL-1 - Surface Mount	8"	36" x 12"	40%	23 - #3 Scratch (stainless steel face)	SD3	Radial Opposed Blade Damper - steel
HPL-HA-AL-6 - T-bar Lay-in	9"	48" x 12"	23%		HEPA	Filter (factory provided)
HPL-HA-AL-6M - Special 1 1/2" T-bar Lay-in	10"	60" x 12"			TP	Test Ports
<b>Stainless Steel Face &amp; Backpan</b>	12"	72" x 12"				
HPL-HA-SS-1 - Surface Mount	14"	24" x 24"				
HPL-HA-SS-6 - T-bar Lay-in		36" x 24"				
HPL-HA-SS-6M - Special 1 1/2" T-bar Lay-in		48" x 24"				
<b>Stainless Steel Face &amp; Aluminum Backpan</b>		60" x 24"				
HPL-HA-SA-1 - Surface Mount		72" x 24"				
HPL-HA-SA-6 - T-bar Lay-in		48" x 36"				
HPL-HA-SA-6M - Special 1 1/2" T-bar Lay-in						

## ➔ Laminar Flow ➔ Patient Isolation Applications ➔ Series HPL-PR

### Product Details

- ★ The series HPL-PR is specifically engineered to improve patient comfort in critical health care applications such as isolation rooms and trauma centers. The unique design provides a "tent" of conditioned air around the patient
- ★ The unique design of the HPL-PR provides filtered air to protect the patient and at the same time minimize the air velocities that impact the patient. This device provides a high level of comfort
- ★ Series HPL-PR includes a HEPA filter section. Optional HEPA filters are available. HPL-PR configuration minimizes induction, distributing low velocity air with minimum aspiration
- ★ Unit is aluminum construction and is available for surface mount and T-bar Lay-in applications, and is also available for special 1 1/2" wide T-bar Lay-in applications



**Model HPL-PR Shown**

Standard Finish: 01 White

Environmental / Hospital Diffusers



EHD

### Aluminum Face & Backpan

Dimensions are in inches

Hospital Diffuser - Patient Room Isolation  
Aluminum Face & Backpan  
Model HPL-PR-AL

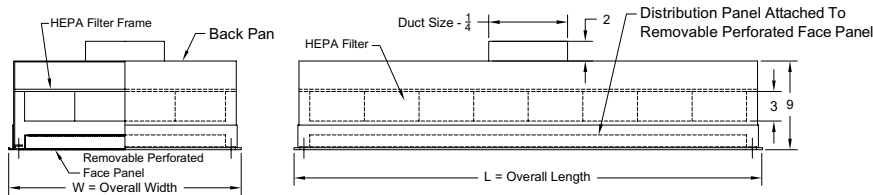

Hospital Diffuser - Patient Room Isolation  
Surface Mount - Aluminum Face & Backpan  
Model HPL-PR-AL-1

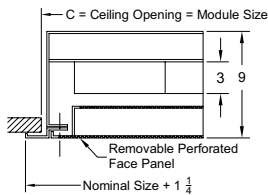

Hospital Diffuser - Patient Room Isolation  
Standard T-bar Lay-in - Aluminum Face & Backpan  
Model HPL-PR-AL-6

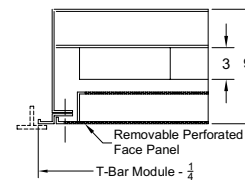

Hospital Diffuser - Patient Room Isolation  
Special 1 1/2" T-bar Lay-in - Aluminum Face & Backpan  
Model HPL-PR-AL-6M

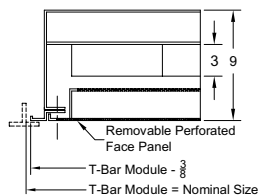

### Cross Section: Diffuser Face

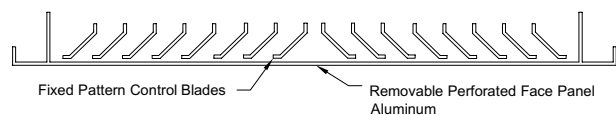

**Stainless Steel Face & Aluminum Backpan**

Hospital Diffuser - Patient Room Isolation  
 Stainless Steel Face & Aluminum Backpan  
 Model HPL-PR-SA

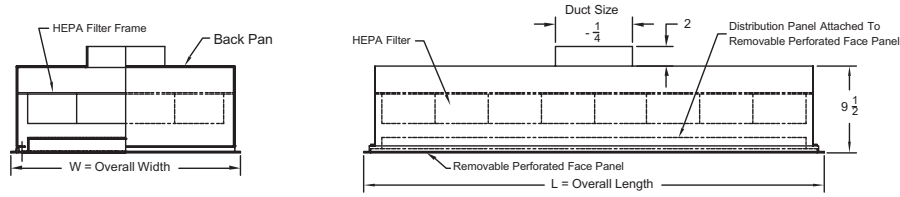

Hospital Diffuser - Patient Room Isolation  
 Surface Mount - Stainless Steel Face & Aluminum Backpan  
 Model HPL-PR-SA-1

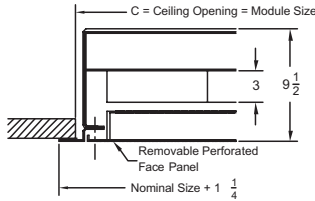

Hospital Diffuser - Patient Room Isolation  
 Standard T-bar Lay-in - Stainless Steel Face & Aluminum Backpan  
 Model HPL-PR-SA-6

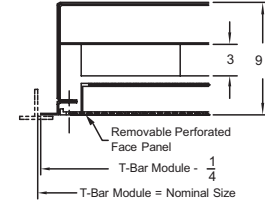

Hospital Diffuser - Patient Room Isolation  
 Special 1 1/2" T-bar Lay-in - Stainless Steel Face & Aluminum Backpan  
 Model HPL-PR-SA-6M

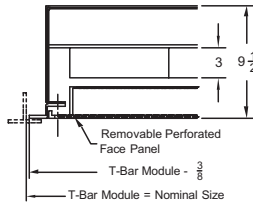

Cross Section: Diffuser Face

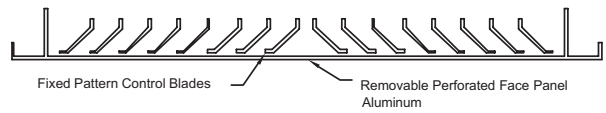

**Series HPL-HA-AL, HPL-HA-SA**

**Air Patterns**

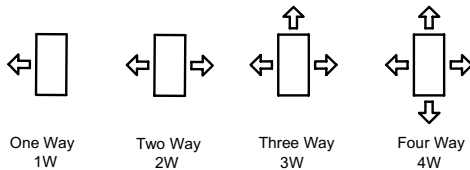

Nominal Size	Frame 1			Frame 6		Frame 6M	
	C	L	W	L	W	L	W
12 x 36	12 x 36	37 1/4	13 1/4	35 3/4	11 3/4	35 5/8	11 5/8
12 x 48	12 x 48	49 1/4	13 1/4	47 3/4	11 3/4	47 5/8	11 5/8
24 x 24	24 x 24	25 1/4	25 1/4	23 3/4	23 3/4	23 5/8	23 5/8
24 x 36	24 x 36	37 1/4	25 1/4	35 3/4	23 3/4	35 5/8	23 5/8
24 x 48	24 x 48	49 1/4	25 1/4	47 3/4	23 3/4	47 5/8	23 5/8



## Stainless Steel Face & Backpan

Hospital Diffuser - Patient Room Isolation  
 Stainless Steel Face & Backpan  
 Model HPL-PR-SS

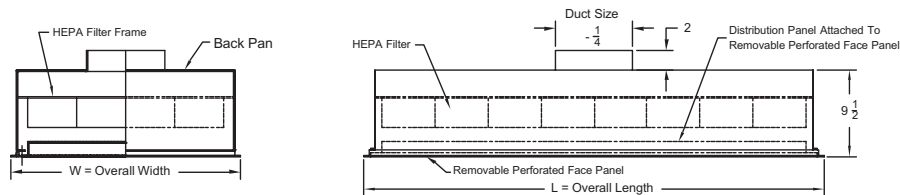

Hospital Diffuser - Patient Room Isolation  
 Surface Mount - Stainless Steel Face & Backpan  
 Model HPL-PR-SS-1

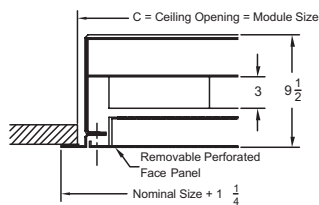

Hospital Diffuser - Patient Room Isolation  
 Standard T-bar Lay-in - Stainless Steel Face & Backpan  
 Model HPL-PR-SS-6

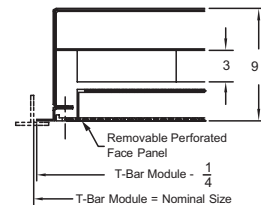

Hospital Diffuser - Patient Room Isolation  
 Special 1 1/2" T-bar Lay-in - Stainless Steel Face & Aluminum Backpan  
 Model HPL-PR-SS-6M

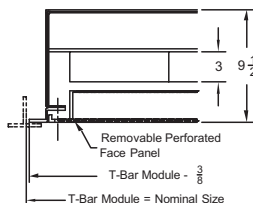

### Cross Section: Diffuser Face

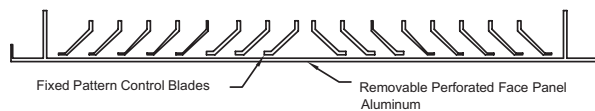

### Air Patterns

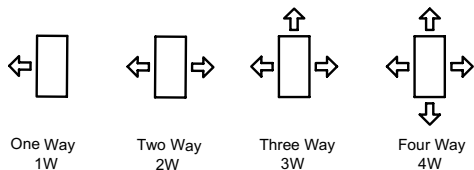

Nominal Size	Frame 1			Frame 6		Frame 6M	
	C	L	W	L	W	L	W
12 x 36	12 x 36	37 1/4	13 1/4	35 3/4	11 3/4	35 5/8	11 5/8
12 x 48	12 x 48	49 1/4	13 1/4	47 3/4	11 3/4	47 5/8	11 5/8
24 x 24	24 x 24	25 1/4	25 1/4	23 3/4	23 3/4	23 5/8	23 5/8
24 x 36	24 x 36	37 1/8	25 1/4	35 3/4	23 3/4	35 5/8	23 5/8
24 x 48	24 x 48	49 1/4	25 1/4	47 3/4	23 3/4	47 5/8	23 5/8

## Notes for Models HPL-PR-AL-1, HPL-PR-AL-6, HPL-PR-AL-6M

1. Available Finishes	2. Available Options	3. Construction Details
Standard Finish: 08 White epoxy powder coat	HEPA Filter CD - Cable Operated Damper TP - Test Port	<ul style="list-style-type: none"> <li>Perforated faces are shipped with 2 safety cables</li> <li>23%, 40%, 51% perforated face</li> <li>Round neck sizes available: 6, 8, 10, 12 &amp; 14</li> <li>Air patterns available: 1W, 2W, 2C, 3W, &amp; 4W</li> </ul>

## Notes for Models HPL-PR-SA-1, HPL-PR-SA-6, HPL-PR-SA-6M

1. Available Finishes	2. Available Options	3. Construction Details
Standard Finish: 08 White epoxy powder coat - Backpan/23 3 scratch - Face	HEPA Filter CD - Cable Operated Damper TP - Test Port	<ul style="list-style-type: none"> <li>Perforated faces are shipped with 2 safety cables</li> <li>23%, 40%, 51% perforated face</li> <li>Round neck sizes available: 6, 8, 10, 12 &amp; 14</li> <li>Air patterns available: 1W, 2W, 2C, 3W, &amp; 4W</li> </ul>

## Notes for Models HPL-PR-SS-1, HPL-PR-SS-6, HPL-PR-SS-6M

1. Available Finishes	2. Available Options	3. Construction Details
Standard Finish: 23 #3 scratch	D3 - Aluminum Radial Opposed Blade Damper SD3 - Steel Radial Opposed Blade Damper RSD - Radial Shutter Damper CD - Cable Damper	<ul style="list-style-type: none"> <li>Perforated faces are shipped with 2 safety cables</li> <li>23%, 40%, 51% perforated face</li> <li>Round neck sizes available: 6, 8, 10, 12 &amp; 14</li> </ul>

## Series HPL-PR - Performance

### HPL-PR Performance Data Without HEPA Filter

CFM Per SQ. Foot	20	30	40	50	60	70	80	90	100
Ps	0.003	0.007	0.013	0.020	0.028	0.039	0.051	0.064	0.079
NC	<17	<17	17	21	<28	34	37	40	41
Throw	1-1-3	1-1-4	1-2-6	1-3-8	2-4-10	2-5-11	3-6-13	5-8-16	6-10-20

### HPL-PR Performance Data With HEPA Filter

CFM Per SQ. Foot	20	30	40	50	60	70	80	90	100
Ps	0.150	0.240	0.334	0.425	0.523	0.625	0.730	0.820	-
NC	<24	<24	29	32	35	39	42	45	-
Throw	1-1-3	1-1-4	1-2-6	1-3-8	2-4-10	2-5-11	3-6-13	5-8-16	-

### Performance Notes for Series HPL-PR:

All data are tested in accordance with ANSI/ASHRAE 70-1991

### Definition of Units:

- Ps - is static pressure loss through the diffuser and does not include velocity pressure
- NC - is based on Lw Re 10<sup>-12</sup> watts, includes 10 dB room attenuation and a maximum inlet velocity of 500 fpm  
Throw values are based on terminal velocity of 150, 100, and 75 fpm, respectively
- NC - values are for single diffuser only
- HEPA - filter is a 3" deep filter, with an efficiency of 99.97% on D-3 micron particles

## Series HPL-PR - Specifications

### Aluminum Construction

- Model HPL-PR-AL-1 – *Surface Mount*
- Model HPL-PR-AL-6 – *Standard T-bar Lay-in*
- Model HPL-PR-AL-6M – *Special 1 1/2" T-bar Lay-in*

### Stainless Steel Construction

- Model HPL-PR-SS-1 – *Surface Mount*
- Model HPL-PR-SS-6 – *Standard T-bar Lay-in*
- Model HPL-PR-SS-6M – *Special 1 1/2" T-bar Lay-in*

### Stainless Steel Face/Aluminum Backpan

- Model HPL-PR-SA-1 – *Surface Mount*
- Model HPL-PR-SA-6 – *Standard T-bar Lay-in*
- Model HPL-PR-SA-6M – *Special 1 1/2" T-bar Lay-in*

Air outlets shall be model HPL-PR-AL (aluminum) or HPL-PR-SS (stainless steel) or HPL-PR-SA (stainless steel face/aluminum backpan) manufactured by METALAIRE. Diffuser shall include an upper and lower pressure chamber and shall generate a low velocity, directional air pattern. Units shall be available in a 1, 2, 3, or 4 way fixed air pattern.

Diffuser shall be constructed of a one-piece perforated face and core assembly that is removable from the backpan with 1/4" turn fasteners accessible from the face. Face and core assemblies mounted with internal spring clips or other mechanical fastening devices are not acceptable. Units shall include stainless steel safety chains attaching the face assembly to the backpan.

Core and face assembly shall be removable to allow sanitizing in an autoclave and allow access to the backpan for cleaning. With the core assembly removed, the inside of the backpan must be completely accessible for cleaning. Units with permanently fixed dampers, baffles or deflectors mounted in the backpan are not acceptable. Face shall be flush with the ceiling surface.

Perforated face shall have a 51% free area with 3/16" holes on 1/4" staggered centers.

Units shall have round inlets. Units shall be designed to integrate into the specified ceiling system. The units shall be the size and quantity as outline in the plans and specifications.

### Performance Specification

The manufacturer shall provide published performance data. Data shall be tested in accordance to ANSI/ASHRAE Standard 70-1991.

### Finish Specification

**Aluminum Face Diffusers:** Units shall be painted with a powered coat, baked on epoxy.

**Stainless Steel Face Diffusers:** # 3 Scratch Finish



## Series HPL-PR - Model Specification Guide

### Series HPL-PR - Patient Room Isolation Hospital Diffusers

Model	Inlet	Module	Free Area	Available Finishes	Air Patterns	Available Options	
<b>Aluminum Face &amp; Backpan</b>	6"	24" x 12"	51%	08 - White epoxy (aluminum face)	1W - One Way	D3	Radial Opposed Blade Damper - aluminum
HPL-PR-AL-1 - Surface Mount	8"	36" x 12"	40%		2W - Two Way Opposite		
HPL-PR-AL-6 - T-bar Lay-in	9"	48" x 12"	23%	23 - #3 scratch (stainless steel face)	3W - Three Way	SD3	Radial Opposed Blade Damper - steel
HPL-PR-AL-6M - Special 1 1/2" T-bar Lay-in	10"	60" x 12"			4W - Four Way		
<b>Stainless Steel Face &amp; Backpan</b>	12"	72" x 12"				HEPA	Filter (factory provided)
HPL-PR-SS-1 - Surface Mount	14"	24" x 24"				TP	Test Ports
HPL-PR-SS-6 - T-bar Lay-in		36" x 24"					
HPL-PR-SS-6M - Special 1 1/2" T-bar Lay-in		48" x 24"					
<b>Stainless Steel Face &amp; Aluminum Backpan</b>		60" x 24"					
HPL-PR-SA-1 - Surface Mount		72" x 24"					
HPL-PR-SA-6 - T-bar Lay-in		48" x 36"					
HPL-PR-SA-6M - Special 1 1/2" T-bar Lay-in							

## ➔ Radial Discharge Pattern ➔ Removable Face ➔ Series HRD-CL

### Product Details

- ✪ The HRD-CL radial discharge pattern diffusers are engineered for supply air distribution in critical environments such as chemistry labs and clean rooms. The diffusers are engineered to supply a low velocity of conditioned air in a radial pattern from the ceiling
- ✪ The HRD-CL radial discharge pattern diffusers are easy to clean and sterilize. The face and core assembly can be removed from the face for cleaning. With the face and core assembly removed, the interior of the backpan and inlet collar are free of obstructions and easy to access
- ✪ The diffuser is available in stainless steel or heavy aluminum construction. Units available in 90° or 180° throw



**Model HRD-CL Shown**

Standard Finish: 01 White

Environmental/Hospital Diffusers



EHD

### Aluminum Face & Backpan

Dimensions are in inches

Radial Discharge Pattern - Removable Face  
Aluminum Face & Backpan  
Model HRD-CL-AL One Way  
Model HRD-CL-AL Two Way

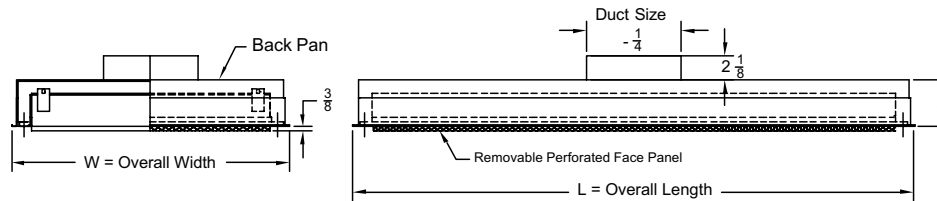

Radial Discharge Pattern - Removable Face  
Surface Mount - Aluminum Face & Backpan  
Model HRD-CL-AL-1

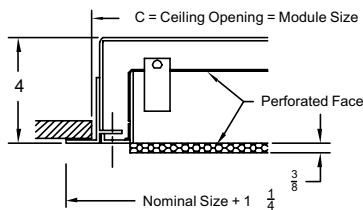

Radial Discharge Pattern - Removable Face  
Standard T-bar Lay-in - Aluminum Face & Backpan  
Model HRD-CL-AL-6

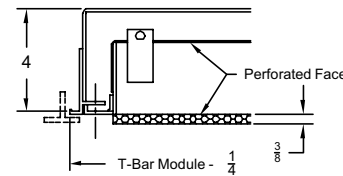

Radial Discharge Pattern - Removable Face  
Special 1 1/2" T-bar Lay-in - Aluminum Face & Backpan  
Model HRD-CL-AL-6M

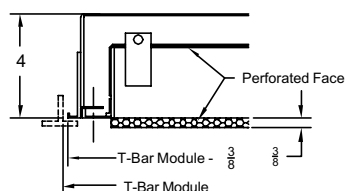

Nominal Size	Frame 1			Frame 6		Frame 6M	
	C	L	W	L	W	L	W
24 x 24	24 x 24	25 1/4	25 1/4	23 3/4	23 3/4	23 5/8	23 5/8
24 x 48	24 x 48	49 1/4	25 1/4	47 3/4	23 3/4	47 5/8	23 5/8

**Stainless Steel Face & Aluminum Backpan**

Radial Discharge Pattern - Removable Face  
 Stainless Steel Face & Aluminum Backpan  
 Model HRD-CL-SA One Way  
 Model HRD-CL-SA Two Way

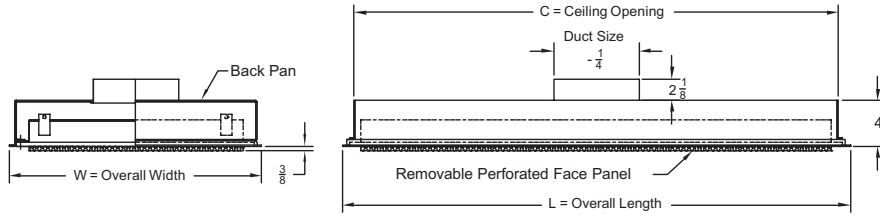

Radial Discharge Pattern - Removable Face  
 Surface Mount - Stainless Steel Face & Aluminum Backpan  
 Model HRD-CL-SA-1

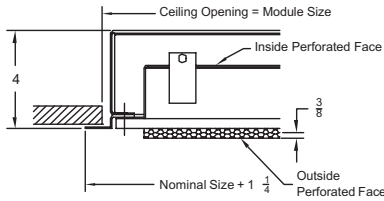

Radial Discharge Pattern - Removable Face  
 Standard T-bar Lay-in - Stainless Steel Face & Aluminum Backpan  
 Model HRD-CL-SA-6

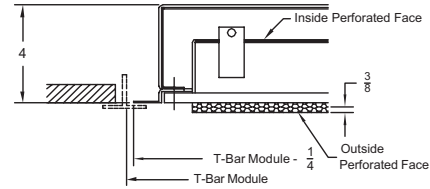

Radial Discharge Pattern - Removable Face  
 Special 1 1/2" T-bar Lay-in - Stainless Steel Face & Aluminum Backpan  
 Model HRD-CL-SA-6M

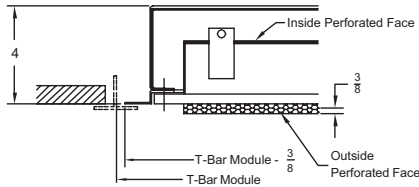

Nominal Size	Frame 1			Frame 6		Frame 6M	
	C	L	W	L	W	L	W
24 x 24	24 x 24	25 1/8	25 1/8	23 3/4	23 3/4	23 3/4	23 3/4
24 x 48	24 x 48	49 1/8	25 1/8	47 3/4	23 3/4	47 3/4	23 3/4

- HRD-CL diffusers discharge air into a 180 degree, radial pattern
- Also available in a 90 degree discharge one-way unit
- HRD-CL generates a low velocity 180 pattern ideal for laboratory and clean room applications

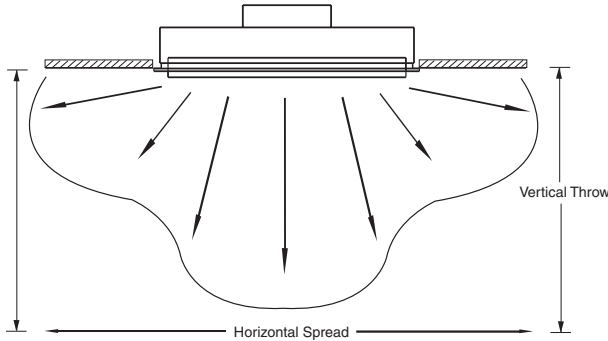
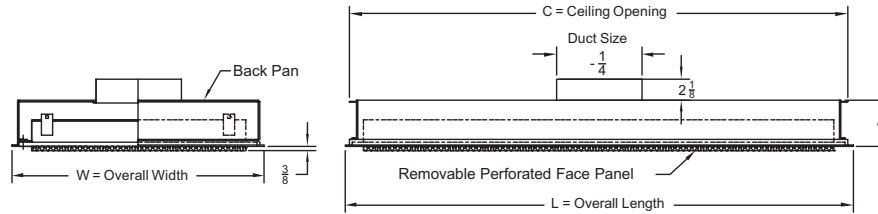

Illustration shows the 180° radial

## Stainless Steel Face & Backpan

Radial Discharge Pattern - Removable Face  
 Stainless Steel Face & Backpan  
 Model HRD-CL-SS One Way  
 Model HRD-CL-SS Two Way



Environmental/Hospital Diffusers

Radial Discharge Pattern - Removable Face  
 Surface Mount - Stainless Steel Face & Backpan  
 Model HRD-CL-SS-1

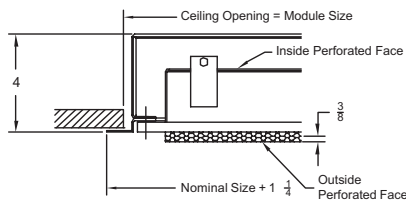

Radial Discharge Pattern - Removable Face  
 Standard T-bar Lay-in - Stainless Steel Face & Backpan  
 Model HRD-CL-SS-6

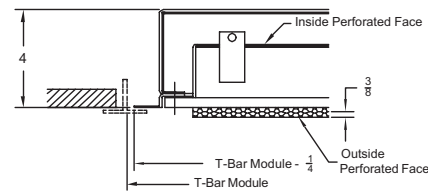

Radial Discharge Pattern - Removable Face  
 Special 1 1/2" T-bar Lay-in - Stainless Steel Face & Backpan  
 Model HRD-CL-SS-6M

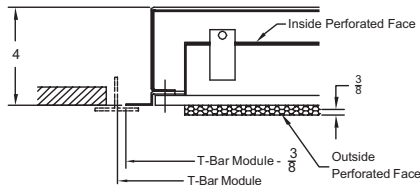

Nominal Size	Frame 1			Frame 6		Frame 6M	
	C	L	W	L	W	L	W
24 x 24	24 x 24	25 1/4	25 1/4	23 3/4	23 3/4	23 5/8	23 5/8
24 x 48	24 x 48	49 1/4	25 1/4	47 3/4	23 3/4	47 5/8	23 5/8

### Notes for Models HRD-CL-AL-1, HRD-CL-AL-6, HRD-CL-AL-6M

1. Available Finishes	2. Available Accessories	3. Available Options	4. Construction Details
Standard Finish: 08 White epoxy powder coat	D3 - Aluminum radial opposed blade damper SD3 - Steel radial opposed blade damper RSD - Radial shutter damper	One way (90° discharge pattern) Two way (180° discharge pattern)	<ul style="list-style-type: none"> <li>Perforated faces are shipped with 2 safety cables</li> <li>51% perforated face</li> <li>Round neck sizes available: 6, 8, 10, 12 &amp; 14</li> </ul>

### Notes for Models HRD-CL-SA-1, HRD-CL-SA-6, HRD-CL-SA-6M

1. Available Finishes	2. Available Accessories	3. Available Options	4. Construction Details
Standard Finish: 23 #2B scratch	D3 - Aluminum radial opposed blade damper SD3 - Steel radial opposed blade damper RSD - Radial shutter damper	One way (90° discharge pattern) Two way (180° discharge pattern)	<ul style="list-style-type: none"> <li>Perforated faces are shipped with 2 safety cables</li> <li>23%, 40%, 51% perforated face</li> <li>Round neck sizes available: 6, 8, 10, 12 &amp; 14</li> </ul>

### Notes for Models HRD-CL-SS-1, HRD-CL-SS-6, HRD-CL-SS-6M

1. Available Finishes	2. Available Accessories	3. Available Options	4. Construction Details
Standard Finish: 23 #2B scratch	D3 - Aluminum radial opposed blade damper SD3 - Steel radial opposed blade damper RSD - Radial shutter damper	One way (90° discharge pattern) Two way (180° discharge pattern)	<ul style="list-style-type: none"> <li>Perforated faces are shipped with 2 safety cables</li> <li>23%, 40%, 51% perforated face</li> <li>Round neck sizes available: 6, 8, 10, 12 &amp; 14</li> </ul>

EHD

**Series HRD-CL - Performance**

Models HRD-CL-AL (-1, -6, -6M), HRD-CL-SS (-1, -6, -6M), HRD-CL-SA (-1, -6, -6M)/1-Way Pattern

Module Size and Inlet Size	1-Way Pattern				Horizontal Spread (feet)			Vertical Throw (feet)								
	Air Flow (CFM)	Ps (in wc.)	Pt (in wc.)	NC	10 Deg dT			10 Deg dT			15 Deg dT		20 Deg dT			
					100	75	50	100	75	50	100	75	50	100	75	50
24" x 24" 8" Inlet	150	0.019	0.030	<15	0	1	3	0	1	2	0	1	2	0	1	4
	200	0.033	0.054	<15	0	1	2	0	1	2	0	1	2	0	1	3
	250	0.052	0.084	18	1	2	5	1	2	4	1	2	5	1	3	6
	300	0.075	0.121	23	1	3	5	1	2	4	1	2	5	2	4	6
	400	0.133	0.215	32	2	4	6	2	3	5	2	4	6	3	5	7
	500	0.207	0.335	39	3	5	7	2	4	5	3	5	7	4	6	8
24" x 24" 10" Inlet	250	0.021	0.034	<15	1	2	5	0	0	1	1	1	3	0	1	3
	325	0.035	0.057	<15	1	3	6	0	1	2	1	2	4	1	1	4
	400	0.053	0.087	21	2	4	7	0	1	4	2	2	5	1	2	5
	475	0.075	0.122	27	3	5	8	1	1	4	2	3	5	1	3	5
	550	0.1	0.164	33	3	5	8	1	2	5	2	3	6	2	3	6
	625	0.13	0.212	37	4	6	9	1	2	5	2	4	7	2	4	7
24" x 48" 10" Inlet	300	0.03	0.049	<15	1	2	6	0	0	2	1	2	3	0	1	3
	400	0.053	0.087	19	2	4	7	0	1	3	1	2	5	1	1	5
	500	0.083	0.135	28	3	5	7	1	1	4	2	3	6	1	2	6
	600	0.12	0.195	34	4	6	8	1	2	5	2	3	7	1	3	7
	800	0.212	0.347	40	5	7	9	1	3	6	3	5	8	2	5	10
	900	0.269	0.439	40	6	7	10	2	3	7	3	5	9	3	6	10
24" x 48" 12" Inlet	500	0.048	0.074	19	1	2	5	1	1	4	1	1	6	1	3	6
	600	0.07	0.106	25	1	3	6	1	2	5	1	2	7	2	4	7
	700	0.095	0.145	30	2	3	7	1	3	6	1	3	8	2	4	9
	800	0.124	0.189	33	2	4	8	2	3	6	2	4	9	3	5	10
	900	0.157	0.239	39	3	4	8	2	4	7	2	5	10	4	5	11
	1000	0.194	0.295	42	3	5	9	3	4	8	3	6	10	4	6	11

Models HRD-CL-AL (-1, -6, -6M), HRD-CL-SS (-1, -6, -6M), HRD-CL-SA (-1, -6, -6M)/2-Way Pattern

Module Size and Inlet Size	2-Way Pattern				Horizontal Spread (feet)			Vertical Throw (feet)								
	Air Flow (CFM)	Ps (in wc.)	Pt (in wc.)	NC	10 Deg dT			10 Deg dT			15 Deg dT		20 Deg dT			
					100	75	50	100	75	50	100	75	50	100	75	50
24" x 24" 8" Inlet	150	0.019	0.030	<15	0	1	3	0	1	2	0	1	2	0	1	4
	200	0.033	0.054	15	1	1	4	0	1	3	0	1	4	1	2	5
	250	0.052	0.084	19	1	2	5	1	2	4	1	2	5	1	3	6
	300	0.075	0.121	23	1	3	5	1	2	4	1	2	5	2	4	6
	400	0.132	0.214	31	2	4	6	2	3	6	2	4	6	3	5	7
	500	0.207	0.335	39	3	5	7	2	4	6	3	5	7	4	6	8
24" x 24" 10" Inlet	250	0.023	0.036	<15	1	2	5	0	0	1	1	1	3	0	1	3
	325	0.039	0.061	<15	1	3	6	0	1	2	1	2	4	1	1	4
	500	0.092	0.145	29	3	5	10	1	1	4	2	3	6	1	3	6
	600	0.133	0.208	36	4	6	11	1	2	5	2	3	7	2	3	7
	700	0.181	0.284	41	5	7	12	1	3	6	3	4	7	2	4	8
	900	0.299	0.469	45	6	9	14	2	4	8	3	5	8	3	5	9
24" x 48" 10" Inlet	250	0.017	0.030	<15	1	2	5	0	0	1	0	1	2	0	1	2
	325	0.028	0.050	<15	1	3	6	0	0	2	1	2	3	0	1	3
	500	0.067	0.119	26	3	5	10	1	1	4	2	2	5	1	2	5
	600	0.096	0.172	33	4	6	11	1	2	4	2	3	6	1	3	6
	700	0.131	0.234	38	5	7	12	1	2	5	2	3	6	2	3	7
	900	0.217	0.387	42	6	9	14	2	3	6	3	4	7	3	4	8
24" x 48" 12" Inlet	500	0.067	0.092	19	3	5	10	1	1	4	1	1	5	1	3	6
	600	0.096	0.133	25	4	6	11	1	2	4	1	2	6	2	3	7
	700	0.131	0.181	30	5	7	12	1	3	5	1	3	7	2	4	8
	800	0.171	0.236	33	5	8	13	2	3	7	2	4	7	3	5	9
	900	0.217	0.299	39	6	9	14	2	3	7	2	4	8	3	5	9
	1000	0.268	0.369	42	3	5	10	2	4	7	3	5	8	4	6	10

**Performance Notes for Series HRD-CL:**

All data are tested in accordance with ANSI/ASHRAE 70-1991

**Definition of Units:**

- CFM - Cubic Feet per Minute (air)
- Pv - Velocity pressure (inches of water column)
- Pt - Total pressure (inches of water column)
- Ps - Static pressure = Pt - Pv (inches of water column)
- Throw - Non-isothermal horizontal throw values are for 150 fpm - 100 fpm - 50 fpm velocities
- NC - Noise criterion, sound pressure level. NC ratings are based on sound power level (Lw) RE: 10E-12 watts minus a 10 dB room attenuation in all octave bands



## Series HRD-CL - Specifications

### Aluminum Construction

- Model HRD-CL-AL-1 – *Surface Mount*
- Model HRD-CL-AL-6 – *Standard T-bar Lay-in*
- Model HRD-CL-AL-6M – *Special 1 1/2" T-bar Lay-in*

### Stainless Steel Construction

- Model HRD-CL-SS-1 – *Surface Mount*
- Model HRD-CL-SS-6 – *Standard T-bar Lay-in*
- Model HRD-CL-SS-6M – *Special 1 1/2" T-bar Lay-in*

### Stainless Steel Face/Aluminum Backpan

- Model HRD-CL-SA-1 – *Surface Mount*
- Model HRD-CL-SA-6 – *Standard T-bar Lay-in*
- Model HRD-CL-SA-6M – *Special 1 1/2" T-bar Lay-in*

Air outlets shall be model HRD-CL-AL (aluminum) or HRD-CL-SS (stainless steel) or HRD-CL-SA (stainless steel face/aluminum backpan) manufactured by METALAIRE. Diffuser shall generate a 180°, two way, low velocity discharge pattern (optional: 90°, one way discharge pattern).

Diffuser shall be constructed of a one-piece perforated face and core assembly that is removable from the backpan with 1/4" turn fasteners accessible from the face. Face and core assemblies mounted with internal spring clips or other mechanical fastening devices are not acceptable. Core Assembly to have non-adjustable pattern controllers mounted on the face assembly. Units shall include stainless steel safety chains attaching the face assembly to the backpan.

Core and face assembly shall be removable to allow sanitizing in an autoclave and allow access to the backpan for cleaning. With the core assembly removed, the inside of the backpan must be completely accessible for cleaning. Units with permanently fixed dampers, baffles or deflectors mounted in the backpan are not acceptable. Face shall project no further than 3/8" below the border of the diffuser. Perforated face shall have a 51% free area with 3/16" holes on 1/4" staggered centers. Units shall have round inlets.

Units shall have round inlets. Units shall be designed to integrate into the specified ceiling system. The units shall be the size and quantity as outline in the plans and specifications.

### Performance Specification

The manufacturer shall provide published performance data. Data shall be tested in accordance to ANSI/ASHRAE Standard 70-1991.

### Finish Specification

**Aluminum Face Diffusers:** Units shall be painted with a powder coat, baked on epoxy.

**Stainless Steel Face Diffusers:** # 2B Mill Finish

## Series HRD-CL - Model Specification Guide

### Series HRD-CL - Hospital Diffusers - Removable Face

Model	Inlet	Module	Discharge Pattern	Available Finishes	Available Options	
<b>Aluminum Face &amp; Backpan</b>	6"	24" x 24"	90° - One Way	08 - White epoxy (aluminum face)	D3	Radial Opposed Blade Damper - aluminum
HRD-CL-AL-1 - Surface Mount	8"	48" x 24"	180° - Two Way	23 - #2B Stainless (stainless steel face)		
HRD-CL-AL-6 - T-bar Lay-in	9"				SD3	Radial Opposed Blade Damper - steel
HRD-CL-AL-6M - Special 1 1/2" T-bar Lay-in	10"					
<b>Stainless Steel Face &amp; Backpan</b>	12"					
HRD-CL-SS-1 - Surface Mount	14"					
HRD-CL-SS-6 - T-bar Lay-in						
HRD-CL-SS-6M - Special 1 1/2" T-bar Lay-in						
<b>Stainless Steel Face &amp; Aluminum Backpan</b>						
HRD-CL-SA-1 - Surface Mount						
HRD-CL-SA-6 - T-bar Lay-in						
HRD-CL-SA-6M - Special 1 1/2" T-bar Lay-in						



## ➔ Radial Discharge Pattern ➔ Removable Face w/HEPA Filter ➔ Series HRD-HA

### Product Details

- ✦ The series HRD-HA radial discharge pattern diffusers includes a HEPA filter section and are engineered for supply air distribution in critical environments such as chemistry labs and clean rooms. The diffusers are engineered to supply a low velocity of conditioned air in a radial pattern from the ceiling
- ✦ The series HRD-HA design includes a HEPA filter cell accessible from the face of the diffuser. The face and core assembly can be removed from the face for cleaning. This feature allows the filters to be removed and replaced from the diffuser face. Optional HEPA filters are available
- ✦ The HRD-HA Radial Discharge Pattern Diffusers are easy to clean and sterilize. The face and core assembly can be removed from the face for cleaning. With the face and core assembly removed, the interior of the backpan and inlet collar are free of obstructions and easy to access
- ✦ The diffuser is available in stainless steel or heavy aluminum construction. Units available in 90° or 180° throw
- ✦ Optional HEPA Filters are available



**Model HRD-HA Shown**

Standard Finish: 01 White

Environmental/Hospital Diffusers



EHD

### Aluminum Face & Backpan

Dimensions are in inches

Radial Discharge Pattern - Removable Face With HEPA Filter  
 Aluminum Face & Backpan  
 Model HRD-HA-AL One Way  
 Model HRD-HA-AL Two Way

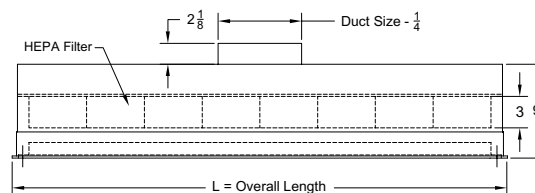
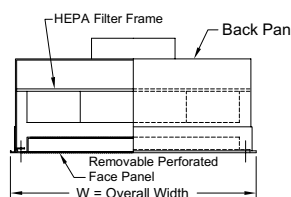

Radial Discharge Pattern - Removable Face With HEPA Filter  
 Surface Mount - Aluminum Face & Backpan  
 Model HRD-HA-AL-1

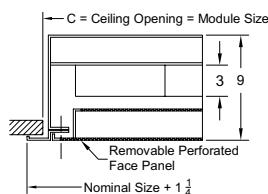

Radial Discharge Pattern - Removable Face With HEPA Filter  
 Standard T-bar Lay-in - Aluminum Face & Backpan  
 Model HRD-HA-AL-6

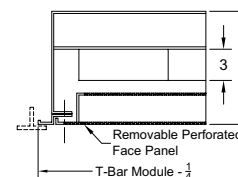



Radial Discharge Pattern - Removable Face With HEPA Filter  
 Special 1 1/2" T-bar Lay-in - Aluminum Face & Backpan  
 Model HRD-HA-AL-6M

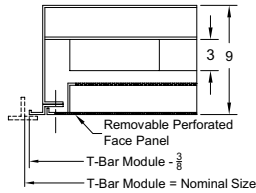

Nominal Size	Frame 1			Frame 6		Frame 6M	
	C	L	W	L	W	L	W
24 x 24	24 x 24	25 1/4	25 1/4	23 3/4	23 3/4	23 3/4	23 3/4
24 x 48	24 x 48	49 1/4	25 1/4	47 3/4	23 3/4	47 3/4	23 3/4

**Stainless Steel Face & Aluminum Backpan**

Radial Discharge Pattern - Removable Face With HEPA Filter  
 Stainless Steel Face & Aluminum Backpan  
 Model HRD-HA-SA One Way  
 Model HRD-HA-SA Two Way

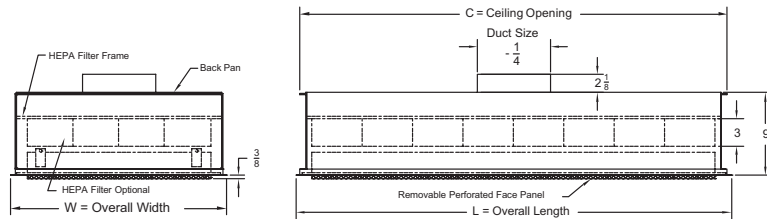

Radial Discharge Pattern - Removable Face With HEPA Filter  
 Surface Mount - Stainless Steel Face & Aluminum Backpan  
 Model HRD-HA-SA-1

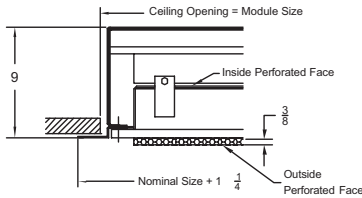

Radial Discharge Pattern - Removable Face With HEPA Filter  
 Standard T-bar Lay-in - Stainless Steel Face & Aluminum Backpan  
 Model HRD-HA-SA-6

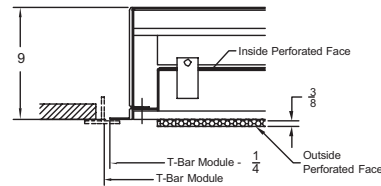

Radial Discharge Pattern - Removable Face With HEPA Filter  
 Special 1 1/2" T-bar Lay-in - Stainless Steel Face & Aluminum Backpan  
 Model HRD-HA-SA-6M

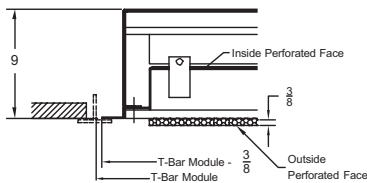

Nominal Size	Frame 1			Frame 6		Frame 6M	
	C	L	W	L	W	L	W
24 x 24	24 x 24	25 1/4	25 1/4	23 3/4	23 3/4	23 5/8	23 5/8
24 x 48	24 x 48	49 1/4	25 1/4	47 3/4	23 3/4	47 5/8	23 5/8

- HRD-HA diffusers discharge air into a 180 degree, radial pattern
- Also available in a 90 degree discharge one-way unit
- HRD-HA generates a low velocity 180 pattern ideal for laboratory and clean room applications

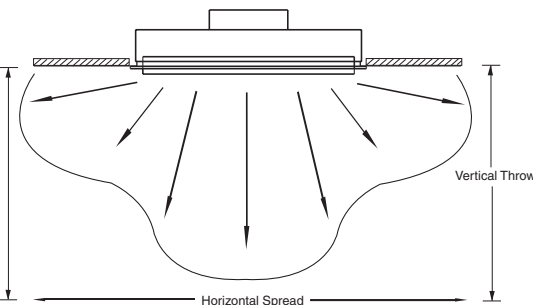
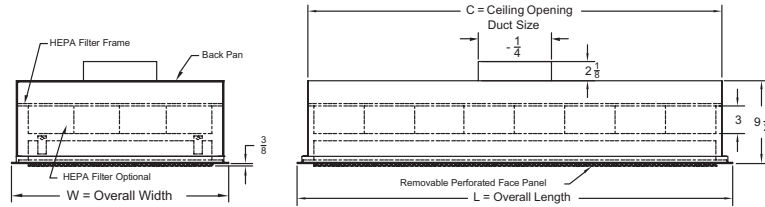

Illustration shows the 180° radial

## Stainless Steel Face & Backpan

Radial Discharge Pattern - Removable Face With HEPA Filter  
 Stainless Steel Face & Backpan  
 Model HRD-HA-SS One Way  
 Model HRD-HA-SS Two Way



Radial Discharge Pattern - Removable Face With HEPA Filter  
 Surface Mount - Stainless Steel Face & Backpan  
 Model HRD-HA-SS-1

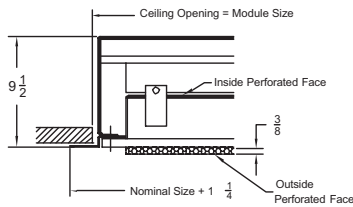

Radial Discharge Pattern - Removable Face With HEPA Filter  
 Standard T-bar Lay-in - Stainless Steel Face & Backpan  
 Model HRD-HA-SS-6

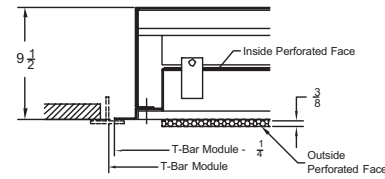

Radial Discharge Pattern - Removable Face With HEPA Filter  
 Special 1 1/2" T-bar Lay-in - Stainless Steel Face & Backpan  
 Model HRD-HA-SS-6M

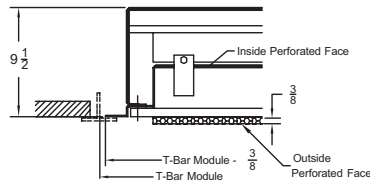

Nominal Size	Frame 1		Frame 6		Frame 6M		
	C	L	W	L	W	L	W
24 x 24	24 x 24	25 1/4	25 1/4	23 3/4	23 3/4	23 5/8	23 5/8
24 x 48	24 x 48	49 1/4	25 1/4	47 3/4	23 3/4	47 5/8	23 5/8

### Notes for Models HRD-HA-AL-1, HRD-HA-AL-6, HRD-HA-AL-6M

1. Available Finishes	2. Available Accessories	3. Available Options	4. Construction Details
Standard Finish: 01 White	CD - Cable Damper	One way (90° discharge pattern) Two way (180° discharge pattern) HEPA Filter	<ul style="list-style-type: none"> <li>Perforated faces are shipped with 2 safety cables</li> <li>51% perforated face</li> <li>Round neck sizes available: 6, 8, 10, 12 &amp; 14</li> </ul>

### Notes for Models HRD-HA-SA-1, HRD-HA-SA-6, HRD-HA-SA-6M

1. Available Finishes	2. Available Accessories	3. Available Options	4. Construction Details
Standard Finish: 23 #2B scratch	CD - Cable Damper	One way (90° discharge pattern) Two way (180° discharge pattern) HEPA Filter	<ul style="list-style-type: none"> <li>Perforated faces are shipped with 2 safety cables</li> <li>23%, 40%, 51% perforated face</li> <li>Round neck sizes available: 6, 8, 10, 12 &amp; 14</li> </ul>

### Notes for Models HRD-HA-SS-1, HRD-HA-SS-6, HRD-HA-SS-6M

1. Available Finishes	2. Available Accessories	3. Available Options	4. Construction Details
Standard Finish: 23 #2B scratch	CD - Cable Damper	One way (90° discharge pattern) Two way (180° discharge pattern) HEPA Filter	<ul style="list-style-type: none"> <li>Perforated faces are shipped with 2 safety cables</li> <li>23%, 40%, 51% perforated face</li> <li>Round neck sizes available: 6, 8, 10, 12 &amp; 14</li> </ul>

Environmental/Hospital Diffusers

EHD

## Series HRD-HA - Performance

Models HRD-HA-AL (-1, -6, -6M), HRD-HA-SS (-1, -6, -6M), HRD-HA-SA (-1, -6, -6M)/1-Way Pattern

Module Size and Inlet Size	1-Way Pattern				Horizontal Spread (feet)			Vertical Throw (feet)								
	Air Flow (CFM)	Ps (in wc.)	Pt (in wc.)	NC	10 Deg dT			10 Deg dT			15 Deg dT		20 Deg dT			
					100	75	50	100	75	50	100	75	50	100	75	50
24" x 24" 8" Inlet	150	0.019	0.030	<15	0	- 1	- 3	0	- 1	- 2	0	- 1	- 2	0	- 1	- 4
	200	0.033	0.054	<15	0	- 1	- 2	0	- 1	- 2	0	- 1	- 2	0	- 1	- 3
	250	0.052	0.084	18	1	- 2	- 5	1	- 2	- 4	1	- 2	- 5	1	- 3	- 6
	300	0.075	0.121	23	1	- 3	- 5	1	- 2	- 4	1	- 2	- 5	2	- 4	- 6
	400	0.133	0.215	32	2	- 4	- 6	2	- 3	- 5	2	- 4	- 6	3	- 5	- 7
500	0.207	0.335	39	3	- 5	- 7	2	- 4	- 5	3	- 5	- 7	4	- 6	- 8	
24" x 24" 10" Inlet	250	0.021	0.034	<15	1	- 2	- 5	0	- 0	- 1	1	- 1	- 3	0	- 1	- 3
	325	0.035	0.057	<15	1	- 3	- 6	0	- 1	- 2	1	- 2	- 4	1	- 1	- 4
	400	0.053	0.087	21	2	- 4	- 7	0	- 1	- 4	2	- 2	- 5	1	- 2	- 5
	475	0.075	0.122	27	3	- 5	- 8	1	- 1	- 4	2	- 3	- 5	1	- 3	- 5
	550	0.1	0.164	33	3	- 5	- 8	1	- 2	- 5	2	- 3	- 6	2	- 3	- 6
	625	0.13	0.212	37	4	- 6	- 9	1	- 2	- 5	2	- 4	- 7	2	- 4	- 7
24" x 48" 10" Inlet	300	0.03	0.049	<15	1	- 2	- 6	0	- 0	- 2	1	- 2	- 3	0	- 1	- 3
	400	0.053	0.087	19	2	- 4	- 7	0	- 1	- 3	1	- 2	- 5	1	- 1	- 5
	500	0.083	0.135	28	3	- 5	- 7	1	- 1	- 4	2	- 3	- 6	1	- 2	- 6
	600	0.12	0.195	34	4	- 6	- 8	1	- 2	- 5	2	- 3	- 7	1	- 3	- 7
	800	0.212	0.347	40	5	- 7	- 9	1	- 3	- 6	3	- 5	- 8	2	- 5	- 10
	900	0.269	0.439	40	6	- 7	- 10	2	- 3	- 7	3	- 5	- 9	3	- 6	- 10
24" x 48" 12" Inlet	500	0.048	0.074	19	1	- 2	- 5	1	- 1	- 4	1	- 1	- 6	1	- 3	- 6
	600	0.07	0.106	25	1	- 3	- 6	1	- 2	- 5	1	- 2	- 7	2	- 4	- 7
	700	0.095	0.145	30	2	- 3	- 7	1	- 3	- 6	1	- 3	- 8	2	- 4	- 9
	800	0.124	0.189	33	2	- 4	- 8	2	- 3	- 6	2	- 4	- 9	3	- 5	- 10
	900	0.157	0.239	39	3	- 4	- 8	2	- 4	- 7	2	- 5	- 10	4	- 5	- 11
	1000	0.194	0.295	42	3	- 5	- 9	3	- 4	- 8	3	- 6	- 10	4	- 6	- 11

Models HRD-HA-AL (-1, -6, -6M), HRD-HA-SS (-1, -6, -6M), HRD-HA-SA (-1, -6, -6M)/2-Way Pattern

Module Size and Inlet Size	2-Way Pattern				Horizontal Spread (feet)			Vertical Throw (feet)								
	Air Flow (CFM)	Ps (in wc.)	Pt (in wc.)	NC	10 Deg dT			10 Deg dT			15 Deg dT		20 Deg dT			
					100	75	50	100	75	50	100	75	50	100	75	50
24" x 24" 8" Inlet	150	0.019	0.030	<15	0	- 1	- 3	0	- 1	- 2	0	- 1	- 2	0	- 1	- 4
	200	0.033	0.054	15	1	- 1	- 4	0	- 1	- 3	0	- 1	- 4	1	- 2	- 5
	250	0.052	0.084	19	1	- 2	- 5	1	- 2	- 4	1	- 2	- 5	1	- 3	- 6
	300	0.075	0.121	23	1	- 3	- 5	1	- 2	- 4	1	- 2	- 5	2	- 4	- 6
	400	0.132	0.214	31	2	- 4	- 6	2	- 3	- 6	2	- 4	- 6	3	- 5	- 7
	500	0.207	0.335	39	3	- 5	- 7	2	- 4	- 6	3	- 5	- 7	4	- 6	- 8
24" x 24" 10" Inlet	250	0.023	0.036	<15	1	- 2	- 5	0	- 0	- 1	1	- 1	- 3	0	- 1	- 3
	325	0.039	0.061	<15	1	- 3	- 6	0	- 1	- 2	1	- 2	- 4	1	- 1	- 4
	500	0.092	0.145	29	3	- 5	- 10	1	- 1	- 4	2	- 3	- 6	1	- 3	- 6
	600	0.133	0.208	36	4	- 6	- 11	1	- 2	- 5	2	- 3	- 7	2	- 3	- 7
	700	0.181	0.284	41	5	- 7	- 12	1	- 3	- 6	3	- 4	- 7	2	- 4	- 8
	900	0.299	0.469	45	6	- 9	- 14	2	- 4	- 8	3	- 5	- 8	3	- 5	- 9
24" x 48" 10" Inlet	250	0.017	0.030	<15	1	- 2	- 5	0	- 0	- 1	0	- 1	- 2	0	- 1	- 2
	325	0.028	0.050	<15	1	- 3	- 6	0	- 0	- 2	1	- 2	- 3	0	- 1	- 3
	500	0.067	0.119	26	3	- 5	- 10	1	- 1	- 4	2	- 2	- 5	1	- 2	- 5
	600	0.096	0.172	33	4	- 6	- 11	1	- 2	- 4	2	- 3	- 6	1	- 3	- 6
	700	0.131	0.234	38	5	- 7	- 12	1	- 2	- 5	2	- 3	- 6	2	- 3	- 7
	900	0.217	0.387	42	6	- 9	- 14	2	- 3	- 6	3	- 4	- 7	3	- 4	- 8
24" x 48" 12" Inlet	500	0.067	0.092	19	3	- 5	- 10	1	- 1	- 4	1	- 1	- 5	1	- 3	- 6
	600	0.096	0.133	25	4	- 6	- 11	1	- 2	- 4	1	- 2	- 6	2	- 3	- 7
	700	0.131	0.181	30	5	- 7	- 12	1	- 3	- 5	1	- 3	- 7	2	- 4	- 8
	800	0.171	0.236	33	5	- 8	- 13	2	- 3	- 7	2	- 4	- 7	3	- 5	- 9
	900	0.217	0.299	39	6	- 9	- 14	2	- 3	- 7	2	- 4	- 8	3	- 5	- 9
	1000	0.268	0.369	42	3	- 5	- 10	2	- 4	- 7	3	- 5	- 8	4	- 6	- 10

**Performance Notes for Series HRD-HA:**

All data are tested in accordance with ANSI/ASHRAE 70-1991

**Definition of Units:**

- CFM - Cubic Feet per Minute (air)
- Pv - Velocity pressure (inches of water column)
- Pt - Total pressure (inches of water column)
- Ps - Static pressure = Pt - Pv (inches of water column)
- Throw - Non-isothermal horizontal throw values are for 150 fpm - 100 fpm - 50 fpm velocities
- NC - Noise criterion, sound pressure level. NC ratings are based on sound power level (Lw)
- RE: 10E-12 watts minus a 10 dB room attenuation in all octave bands

For more product information visit us at [www.metalair.com](http://www.metalair.com)



## Series HRD-HA - Specifications

### Aluminum Construction

- Model HRD-HA-AL-1 – *Surface Mount*
- Model HRD-HA-AL-6 – *Standard T-bar Lay-in*
- Model HRD-HA-AL-6M – *Special 1 1/2" T-bar Lay-in*

### Stainless Steel Construction

- Model HRD-HA-SS-1 – *Surface Mount*
- Model HRD-HA-SS-6 – *Standard T-bar Lay-in*
- Model HRD-HA-SS-6M – *Special 1 1/2" T-bar Lay-in*

### Stainless Steel Face/Aluminum Backpan

- Model HRD-HA-SA-1 – *Surface Mount*
- Model HRD-HA-SA-6 – *Standard T-bar Lay-in*
- Model HRD-HA-SA-6M – *Special 1 1/2" T-bar Lay-in*

Air outlets shall be model HRD-HA-AL (aluminum) or HRD-HA-SS (stainless steel) or HRD-HA-SA (stainless steel face/aluminum backpan) manufactured by METALAIRE. Diffuser shall include an upper and lower pressure chamber and shall generate a 180, two way, low velocity discharge pattern (optional: 90°, one way discharge pattern). Unit shall also include an internal filter section to allow the installation and removal of a HEPA filter. Unit shall accept 3" beadpleat HEPA with filter held in place using a trapeze hanger system.

Diffuser shall be constructed of a one-piece perforated face and core assembly that is removable from the backpan with 1/4" turn fasteners accessible from the face. Face and core assemblies mounted with internal spring clips or other mechanical fastening devices are not acceptable. Core Assembly to have non-adjustable pattern controllers mounted on the face assembly. Units shall include stainless steel safety chains attaching the face assembly to the backpan.

**Optional:** A factory installed 3" thick, 99.99% efficient filter on .30 microns shall be provided by the diffuser manufacturer.

Core and face assembly shall be removable to allow sanitizing in an autoclave and allow access to the backpan for cleaning. With the core assembly removed, the inside of the backpan must be completely accessible for cleaning. Units with permanently fixed dampers, baffles or deflectors mounted in the backpan are not acceptable. Face shall project no further than 3/8" below the border of the diffuser. Perforated face shall have a 51% free area with 3/16" holes on 1/4" staggered centers. Units shall have round inlets.

Units shall have round inlets. Units shall be designed to integrate into the specified ceiling system. The units shall be the size and quantity as outline in the plans and specifications.

### Performance Specification

The manufacturer shall provide published performance data. Data shall be tested in accordance to ANSI/ASHRAE Standard 70-1991.

### Finish Specification

**Aluminum Face Diffusers:** Units shall be painted with a powered coat, baked on epoxy.

**Stainless Steel Face Diffusers:** #2B Mill Finish



## Series HRD-HA - Model Specification Guide

### Series HRD-HA - Hospital Diffusers - Removable Face With HEPA Filter

Model	Inlet	Module	Discharge Pattern	Available Finishes	Available Options	
<b>Aluminum Face &amp; Backpan</b>	6"	24" x 24"	90° - One Way	08 - White epoxy (aluminum face)	D3	Radial Opposed Blade Damper - aluminum
HRD-HA-AL-1 - Surface Mount	8"	48" x 24"	180° - Two Way	23 - #2B Stainless (stainless steel face)		
HRD-HA-AL-6 - T-bar Lay-in	9"					
HRD-HA-AL-6M - Special 1 1/2" T-bar Lay-in	10"					
<b>Stainless Steel Face &amp; Backpan</b>	12"					
HRD-HA-SS-1 - Surface Mount	14"				SD3	Radial Opposed Blade Damper - steel
HRD-HA-SS-6 - T-bar Lay-in					HEPA	Filter (factory provided)
HRD-HA-SS-6M - Special 1 1/2" T-bar Lay-in					TP	Test Ports
<b>Stainless Steel Face &amp; Aluminum Backpan</b>						
HRD-HA-SA-1 - Surface Mount						
HRD-HA-SA-6 - T-bar Lay-in						
HRD-HA-SA-6M - Special 1 1/2" T-bar Lay-in						





## ➔ Laminar Flow ➔ Operating Room Distribution Systems ➔ Periflow System

### Product Details

- ✦ The Periflow operating room air distribution system provides control over particulate matter within the operating room environment
- ✦ The system has been tested in accordance with the guidelines set forth by the Committee on Operating Room Environments of the American College of Surgeons as published in the January, 1976 Bulletin, and meets Class 1 Microbiological Air Cleanliness guidelines. The system provides the highest standard of air cleanliness for patients undergoing minor procedures or surgeries as critical as organ transplants
- ✦ The system is in either stainless steel or heavy aluminum construction to ensure long-term durability and resistance to strong germicidal solutions. In addition, each system is custom designed and precisely fabricated to accommodate the specialized medical, mechanical, and electrical considerations of today's operating room environments
- ✦ By its compact yet efficient design, the Periflow system allows the designer the flexibility to properly provide for all the various components competing for space above the operating room ceiling



**Model Periflow Shown**

Standard Finish: 01 White



### Principles of Operation - Periflow System

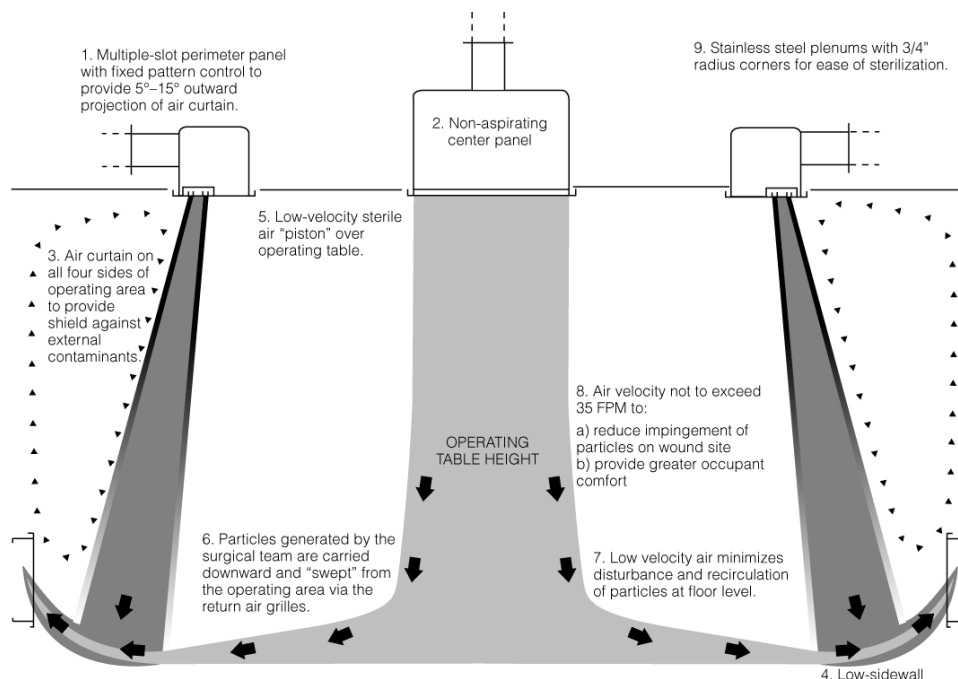

Reflected Ceiling View

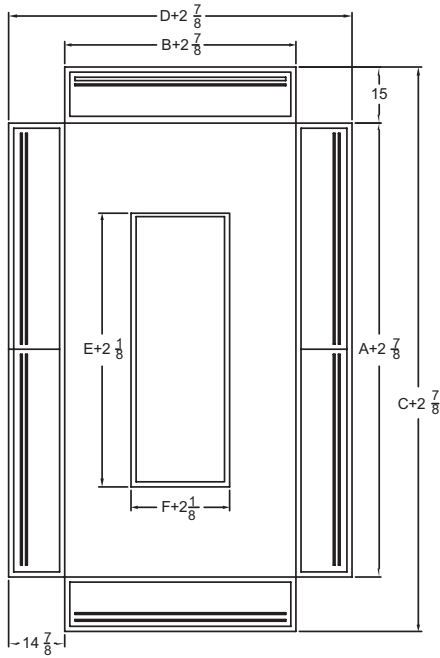

Duct Top View

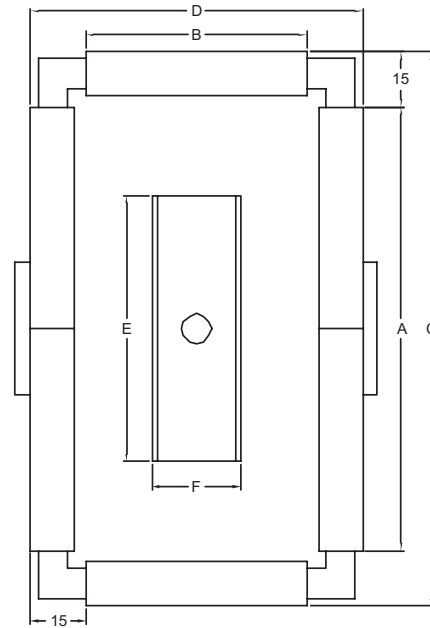

Typical Section View

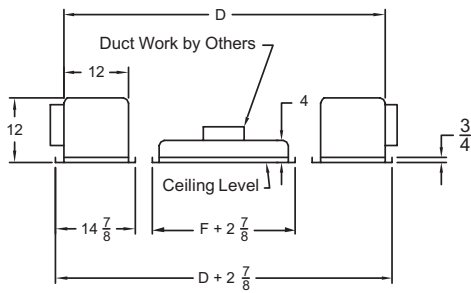

Model	Nominal Duct Sizes		Overall Duct Sizes		Center Panel Duct Sizes		CFM Range
	A	B	C	D	E	F	
84	8'	4'	10' 6"	6' 6"	5'	2'	800-1000
104	10'	4'	12' 6"	6' 6"	6'	2'	1000-2000
124	12'	4'	14' 6"	6' 6"	8'	1' 6"	1100-2200
85	8'	5'	10' 6"	7' 6"	5'	2'	900-1800
105	10'	5'	12' 6"	7' 6"	6'	2'	1050-2010
125	12'	5'	14' 6"	7' 6"	8'	1' 6"	1150-2300
86	8'	6'	10' 6"	8' 6"	4'	3'	1000-2000
106	10'	6'	12' 6"	8' 6"	5'	3'	1100-2200
126	12'	6'	14' 6"	8' 6"	7'	2'	1200-2400
108	10'	8'	12' 6"	10' 6"	7'	2'	1200-2400
128	12'	8'	14' 6"	10' 6"	8'	2'	1350-2700
148	14'	8'	16' 6"	10' 6"	9'	2'	1500-3000

1. Available Finishes	2. Construction Details
<b>Standard Finish:</b> <i>AL Periflow:</i> Exterior - White epoxy powder coat Interior - Mill finish <i>SS Periflow:</i> Exterior - Scratch Interior - Smooth	<i>AL Periflow:</i> Plenum - H3003 Aluminum .050" Frame - H3003 Aluminum .063" <i>SS Periflow:</i> Plenum - 304 SS 20 Ga Frame - 304 SS 18 Ga

## Periflow System - Performance

### Velocities

Center Panels (in Feet Per Minute)

Distance in Feet	CFM per Square Foot of Panel		
	25	35	45
2'	40	42	45
4'	35	38	45
6'	28	32	35

Perimeter Panels (in Feet Per Minute)

Distance in Feet	CFM per Lineal Foot of Panel		
	25	35	45
2'	110	120	130
4'	70	75	80
6'	35	50	65

Velocities are in Feet Per Minute (fpm) at the distance listed in feet from the face of the diffuser. Values shown for center panels are average velocity; values shown for perimeter are peak velocity.

### System Static Requirement

CFM per Square/Lineal Foot	Center Panel	Perimeter Panel
25'	.067	.025
30'	.098	.035
35'	.130	.050
40'	.170	.060
45'	.210	.080

Static pressure values are in inches W.G. and are based on an inlet velocity of 500 fpm. Center panel values are based on CFM per square foot of face panel and perimeter panels are based on CFM per lineal foot of panel.

### Noise Criteria

CFM per Lineal Foot of Perimeter Panel	NC
25'	<20
30'	23
35'	30
40'	34
45'	37

All values are based on Model 148 (44 perimeter feet) and a single center panel. Add one (1) NC for each additional four (4) lineal feet of perimeter panel. Add three (3) NC for each additional four (4) square feet of center panel over a cumulative total of ten (10) square feet. All values are based on 10dB room absorption and PWL dB ref. 10-12 watts. System NC values are based on 1/3 of total airflow to the center panels.

## Selecting a Periflow Operating Room System

Determine the CFM required based on the number of room changes per hour that are required. The formula for this is as follows:

$$\frac{\text{Total changes per hour} \times \text{room volume}}{60 \text{ min/hr}} = \text{Required CFM}$$

After determining the total CFM required, select the Periflow System with a mid-range CFM as close as possible to the total required CFM. The perimeter system will receive two-thirds of the CFM. Selection of the mid supply will be maintained. Maximum recommended CFM per lineal foot perimeter supply is 45.

### Structural and Seismic Considerations

For structural and seismic calculations, the perimeter plenum system (including elbows) will weigh 12.7 lbs. per lineal foot and the center panels will weigh 7.6 lbs per square foot.

The above weights are based on the standard construction and plenum height as shown on the Periflow specification drawing.

## Periflow System - Specifications

### Hospital Operating Room Air Distribution System - Air Curtain System

1. Air distribution and particle control for the operating room(s) shall consist of a non-aspirating center panel(s) providing air supply over the operating table. The air velocity from the center panel(s) shall not exceed 40 fpm at operating table height. An air curtain shall be provided from fixed, nonadjustable multiple slot panels surrounding the operating table height. This air curtain shall not exceed 60 fpm or be of a laminar pattern but shall project air outward at not less than a 5-degree angle, but no more than a 15-degree angle, outward from the operating table with a temperature differential between supply and ambient room temperature of 0 to 20 degrees Fahrenheit (cooling). Systems that do not contain an air current as an inherent part of their design shall not be acceptable.
2. All components of the system shall be fabricated of stainless steel. All ductwork supplied by the contractor from the HEPA filters to the system shall be provided to permit manual sterilization of the ductwork. Factory supplied plenums shall be constructed of a minimum of 20-gauge Type 304 (18-8) stainless steel with a 3/4 inch radius for ease of sterilization. The center panel(s) shall be constructed of 20-gauge Type 304 stainless steel. The perimeter panel(s) shall be constructed of a minimum 18-gauge Type 304 stainless steel. All exposed surfaces shall be supplied with #4 (scratch) finish. All interior surfaces shall be supplied with #2B (smooth) finish to prevent the accumulation of particulate matter. Systems using materials other than stainless steel or supplying component with a painted or coated finish shall not be acceptable.
3. The contractor shall supply manual balancing dampers at each inlet connection to the system also constructed of a minimum of 20-gauge stainless steel. Each center panel shall be provided with a single inlet connection and the perimeter plenum system shall be supplied with two inlet connections. Systems utilizing more than two inlet connections to the perimeter plenum shall not be acceptable.
4. A stainless steel perforated pressure plate supplied by the system manufacturer shall be permanently attached to both the center and perimeter panels to provide equal air distribution over the diffuser face. Both center and perimeter panels shall be retained by quarter turn fasteners for ease of removal for sterilization. The manufacturer shall supply clip-on safety cables to retain the face panels after the quarter turn fasteners are released.
5. An installation shall have been tested in accordance with the "Recommended Procedure for the Determination of Microbiological Air Cleanliness," as published by the Committee on Operating Room Environment of the American College of Surgeons (January, 1976 Bulletin) by an Independent Microbiological Testing Laboratory. The proposed system shall have met the requirements for Class 1 Microbiological Air Cleanliness as set forth in this procedure. Copies of the Independent Laboratory's test report shall be provided to the engineer for prior approval. The manufacturer shall submit a listing of 25 or more systems of the setup as shown.
6. **Optional:** The manufacturer shall provide the services of a qualified factory engineer or technician to supervise the balancing of the system(s). The manufacturer shall provide a complete balancing report to the engineer within two weeks of completion of the system(s) balancing.
7. The air distribution and airborne article control system for the operating room(s) shall be the Periflow Operating Room System as manufactured by METALAIRE or approved equal.

### Performance Specification

The manufacturer shall provide published performance data. Data shall be tested in accordance to ANSI/ASHRAE Standard 70-1991.

## Periflow System - Microbiologic Air Cleanliness Summary

PathCon, Inc. of Atlanta, Georgia, conducted field tests on one Periflow Air Operating Room System. These tests were conducted in accordance with the Recommended Procedures of the Committee on Operating Room Environment of the American College of Surgeons in an article entitled "Definition of Surgical Microbiological Clean Air," published in the January, 1976 Bulletin of the College.

In this document, three (3) classes of air cleanliness as well as the methodology for taking samples were defined. The three (3) classes of microbiologic air cleanliness are as follows:

**Class 1:** Viable microbiological airborne to average less than one particle per cubic foot of air with a minimum sample of 30 cubic feet of air.

**Class 5:** Viable microbiological airborne particle counts to average more than one and up to five per cubic foot of air with a minimum sample of ten cubic feet.

**Class 20:** Viable microbiological airborne particle counts not to average more than five and not to exceed 20 per cubic foot of air with a minimum sample of ten cubic feet.

The test was conducted in an operating room 26' 6" x 22' 0" with a ten foot ceiling height. The Periflow System installed was the standard Model 1610 with a single 2' x 6' center panel. The CFM was 1820 for the perimeter panels (35 CFM per lineal foot) and 500 CFM for the center panel (45 CFM per square foot) for a total of 25 room changes per hour.

The test procedure was to collect samples of air utilizing two Anderson Six Stage Impaction Samplers, one placed at the operating table and the other located outside the air curtain near the door of the operating room. Samples were collected on three runs with volunteers to simulate the surgical team and a patient and one sample was collected with no one in the room as a control sample. Each run was 30 minutes in length as described in the American College of Surgeons Procedures.

*The summary of the samples is presented in the table shown below. The air sampling results are of bacterial colony counts per plate after 72 hours of incubation. Each sample represents thirty cubic feet of air ( 30 Ft.<sup>3</sup> )*

Run*	Six Stage Impaction Samplers	Count at Operating Table with Air Curtain	Count Outside Air Curtain
<b>1</b>	1	0	20
	2	1	4
	3	0	4
	4	0	5
	5	1	6
	6	0	175
	<b>Total</b>	<b>2</b>	<b>214</b>
	<b>Allowable</b>	<b>30 Max</b>	-
<b>2</b>	1	0	8
	2	1	4
	3	0	2
	4	2	3
	5	7	7
	6	0	0
	<b>Total</b>	<b>10</b>	<b>24</b>
	<b>Allowable</b>	<b>30 Max</b>	-
<b>3</b>	1	5	8
	2	1	4
	3	0	2
	4	0	3
	5	1	7
	6	0	0
	<b>Total</b>	<b>7</b>	<b>24</b>
	<b>Allowable</b>	<b>30 Max</b>	-
<b>4</b>	1	0	13
	2	0	12
	3	0	83
	4	1	3
	5	1	4
	6	0	1
	<b>Total</b>	<b>2</b>	<b>100</b>
	<b>Allowable</b>	<b>30 Max</b>	-

*\* Samples 1 through 3 were taken under simulated operating conditions. Sample four is a control sample.*

### The Conclusion of PathCon Laboratories:

"All four samples taken within the air curtain produced by the Periflow System were within the recommended guidelines (for Class 1 Microbiologic Air Cleanliness) as recommended by the ACS. The mean count obtained in the air curtain was 0.125 CFU/F<sup>3</sup>. This is well below the 1 colony forming unit per cubic foot level recommended by the ACS. Comparison sampling outside the air curtain revealed counts 4.8 greater than the ACS recommended level. In summary, the Periflow System was capable of delivering air with microbial counts well within the recommended guidelines even when ambient air exceeded recommended levels."



## Periflow System - Assembly, Operation & Maintenance Procedures

### Operation and Maintenance Procedures

#### **Initial Start Up**

Once the Periflow System has been properly installed (according to the installation diagrams supplied with the submittal) the system must be balanced in accordance with the schedule shown on the plans. It is essential that the CFM be supplied to the center panel, and that the perimeter is adjusted to the values shown on the schedule. This is accomplished by adjusting the inlet dampers (supplied by others) until the proper CFM levels are obtained. Failure to properly balance the system may compromise the perimeter air curtain, so care must be taken in balancing the system.

#### **Decontamination**

After the system is balanced and before the system is placed into operation, all components of the system downstream of the HEPA filter (including duct work) must be decontaminated. All face panels (both center and perimeter) are supplied with quarter turn fasteners on staggered centers. The fasteners are staggered to prevent improper installation of the center panels.

To decontaminate the system, first remove the center panel and perimeter face panels. This is done by turning the quarter turn fastener with a flathead screwdriver to the unlocked position. The center panel and pressure plate that is attached is further secured by a safety cable and snap. Unsnap the safety cable to complete the removal. The center panels can then be sterilized by immersion in a germicidal solution or placed in an autoclave if available. With the face panels removed, the distribution plenums are now accessible. These are provided with round corners to facilitate cleaning. All surfaces should be sterilized by wiping with a germicidal solution, including all duct work downstream of the HEPA filter. Failure to sterilize all components downstream of the HEPA filter may result in contamination of the operating area by microbiologically active particles.

Once all components of the system are sterilized, the center panels can be reinstalled. Care should be taken not to contaminate the now sterilized center panels during re-installation. Sterile clothing and gloves for maintenance personnel are recommended. Maintenance personnel should be instructed to reattach the safety cable prior to securing the face panels to the plenum using the quarter turn fastener. Once the balancing and decontamination process has been complete, the Periflow System is ready for use.

#### **Maintaining the System**

All components of the Periflow System are fabricated from stainless steel to provide years of durable use. It is essential that the decontamination process listed above is repeated after the HEPA filters are changed.

While the Periflow System does not contain movable parts that require continual maintenance, an ongoing maintenance program is recommended. The Periflow System is designed to minimize the accumulation of particulates and in that respect, is essentially self-cleaning. However, the possibility does exist for the occasional contaminant to escape from the HEPA filter and become lodged in the system. It is recommended that the decontamination process be repeated periodically, depending upon the usage of the particular operating room.

### **Assembly & Installation**

The Periflow System has been designed to provide the most efficient operating room air distribution system available while minimizing usage of ceiling space. To ensure proper installation, a drawing illustrating the assembly and installation details must accompany each Periflow submittal.

A few of the design features of the Periflow System which contribute to the ease of assembly and installation are as follows:

- *Perimeter plenums are shipped in maximum lengths of 12' and supplied with pre-drilled flanges at either end. Longer sections are also flanged and supplied with pre-drilled bolt holes for connecting sections.*
- *Connecting elbows are flanged to meet the flanges at either end of the perimeter plenum (also supplied with pre-drilled bolt holes).*
- *Plenums are shipped first so installation with threaded rod (by others) can be completed before the ceiling is installed.*
- *Diffuser mounting frame is shipped loose to be installed after the ceiling to allow for any ceiling irregularities.*
- *The plenum flange is pre-notched to accommodate the quarter turn fasteners that are permanently affixed to the diffuser face panels.*
- *All inlet connections are provided with flanges for ease of duct connection. Raw connections are also available if so specified.*

## Periflow System - Appendix

PathCon Laboratories was selected to perform the Periflow% System microbiologic air cleanliness tests based on their impressive qualifications, experience and expertise in the area of microbial analysis.

Members of the PathCon staff were part of the CDC's control team for spearheading the first isolation of Legionella bacteria (Legionnaire's Disease) in 1978. In addition, they were also instrumental in developing laboratory methods and standards for isolating the bacteria which are now in use throughout the world. The primary emphasis of this laboratory is to assist the industry in reducing business-associated disease risks. They offer investigation and consultation services to determine the quality of the indoor air and water in environmental and occupational settings.



# LEADING THE INDUSTRY IN PRODUCT LITERATURE

With the choice of our Pre-Flite Catalog, Quick Select Catalog, InfoSource Catalog, InfoSource CD and our web site, [www.metalaire.com](http://www.metalaire.com), you pick the format for product information that best suits your air distribution design needs.

## Pre-Flite - Product Overview Catalog

The METALAIRE Pre-Flite catalog is a condensed reference guide containing concise listings of our entire product line including grilles, registers, diffusers, and air terminal units. This catalog can be used to help select the type of device, along with available border styles. The catalog includes photos of each model along with the features and model guide, a great tool when you are trying to select a device for your project.



## Quick Select Catalog - Air Distribution Selection Made Easy

The METALAIRE Quick Select Catalog is designed to save you time selecting air distribution equipment. This catalog is a compact version of our InfoSource Catalogs and includes drawings and performance for our most popular products. The Quick Select Catalog is broken into product types with each section beginning with a model summary that includes features and benefits of our products. To obtain product information not included in the Quick Select Catalog, simply go to our web site at [www.metalaire.com](http://www.metalaire.com).



## InfoSource Catalog Suite - Complete guide to Air Distribution Selection

The METALAIRE InfoSource Catalog suite is the leading product catalog in the industry. Included in these catalogs are the complete product listings, drawings, product features and benefits, product performance data, specifications, and model specifications. These catalogs are organized to make it quick and easy to find the information you are looking for.

### InfoSource Catalog Suite

- Ceiling Diffusers Catalog
- Grilles & Registers Catalog
- Air Terminal Unit Catalog
- Formations Catalog



## InfoSource CD

Our InfoSource CD has set the standard in the industry for air distribution product selection. This CD contains a complete library of all our catalogs and submittals along with our air terminal unit selection program.



## Web Site: [www.metalaire.com](http://www.metalaire.com)

METALAIRE leads the industry with a web site that contains all the product literature and performance data needed to design your air distribution system. Our web site includes all our submittals, catalogs, installation manuals, as well as as other valuable information to aid you in air distribution design.



**METALAIRE**  
EXPERIENCE AIRE SUPERIORITY.

# TRIM

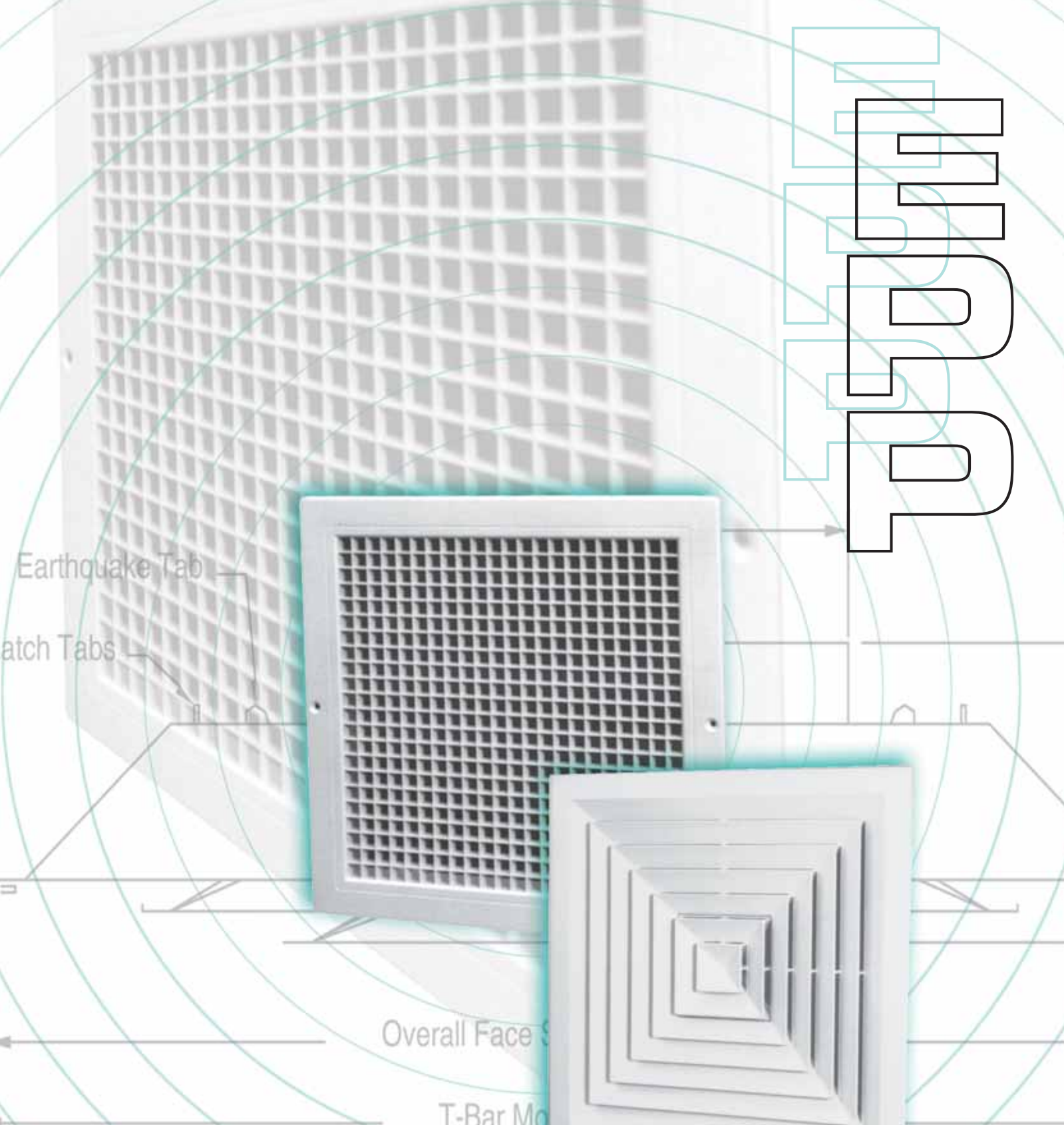

**ENGINEERED POLYMER PRODUCTS**

ENGINEERED POLYMER PRODUCTS





## Engineered Polymer Ceiling Diffusers - Louver Face - Series EP5000

- ✦ For use in ceiling applications which call for a clean, smooth appearance, lightweight, corrosion resistant, and ease of installation
- ✦ For flush surface mount or inverted T-bar Lay-in ceiling grid systems

Model EP5000  
Pg. 300

Surface Mount	T-bar Lay-in
EP5000-1	EP5000-6



## Engineered Polymer Cube Core - Eggcrate Return/Exhaust - Series EPCC5

- ✦ Attractive 1/2" x 1/2" grid by 1/2" deep design
- ✦ Available for non-ducted applications
- ✦ Can be used with an aluminum transition for use with round duct.

Model EPCC5  
Pg. 304

Surface Mount
EP-CC5-1



## Engineered Polymer Grilles & Registers - Louver Face Return/Exhaust - Series EPRH

- ✦ Fixed 45° angled deflecting blades provide a vision obscured appearance
- ✦ Horizontal 45° angled fixed vanes are on 3/4" centers

Model EPRH  
Pg. 308



# LEADING THE INDUSTRY IN PRODUCT LITERATURE

With the choice of our Pre-Flite Catalog, Quick Select Catalog, InfoSource Catalog, InfoSource CD and our web site, [www.metalaire.com](http://www.metalaire.com), you pick the format for product information that best suits your air distribution design needs.

## Pre-Flite - Product Overview Catalog

The METALAIRES Pre-Flite catalog is a condensed reference guide containing concise listings of our entire product line including grilles, registers, diffusers, and air terminal units. This catalog can be used to help select the type of device, along with available border styles. The catalog includes photos of each model along with the features and model guide, a great tool when you are trying to select a device for your project.



## Quick Select Catalog - Air Distribution Selection Made Easy

The METALAIRES Quick Select Catalog is designed to save you time selecting air distribution equipment. This catalog is a compact version of our InfoSource Catalogs and includes drawings and performance for our most popular products. The Quick Select Catalog is broken into product types with each section beginning with a model summary that includes features and benefits of our products. To obtain product information not included in the Quick Select Catalog, simply go to our web site at [www.metalaire.com](http://www.metalaire.com).



## InfoSource Catalog Suite - Complete guide to Air Distribution Selection

The METALAIRES InfoSource Catalog suite is the leading product catalog in the industry. Included in these catalogs are the complete product listings, drawings, product features and benefits, product performance data, specifications, and model specifications. These catalogs are organized to make it quick and easy to find the information you are looking for.

### InfoSource Catalog Suite

- Ceiling Diffusers Catalog
- Grilles & Registers Catalog
- Air Terminal Unit Catalog
- Formations Catalog



## InfoSource CD

Our InfoSource CD has set the standard in the industry for air distribution product selection. This CD contains a complete library of all our catalogs and submittals along with our air terminal unit selection program.



## Web Site: [www.metalaire.com](http://www.metalaire.com)

METALAIRES leads the industry with a web site that contains all the product literature and performance data needed to design your air distribution system. Our web site includes all our submittals, catalogs, installation manuals, as well as as other valuable information to aid you in air distribution design.



## ➔ Square Louver Face ➔ Injection Molded Engineered Polymer ➔ Series EP5000

### Product Details

- ✦ For use in ceiling applications which call for a clean, smooth appearance, lightweight, corrosion resistant, and ease of installation
- ✦ For flush surface mount or inverted T-bar Lay-in ceiling grid systems



**Model EP5000 Shown**

Standard Finish: 01 White

Dimensions are in inches

Square Louver Face Ceiling Diffusers - Injection Molded Engineered Polymer  
Model EP5000 - (Options with Dampers are not showed)

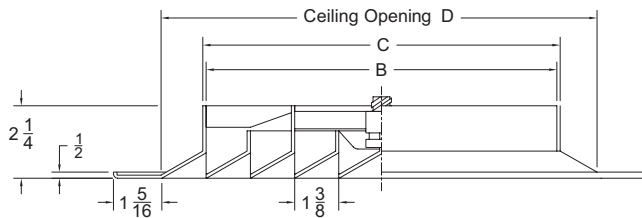

Face View  
Model EP5000

Size 9 x 9, 12 x 12, 18 x 18 (Face View)

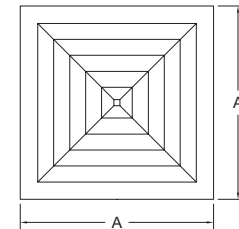

Kit Contains 4 Baffles  
9 x 9 Neck Size

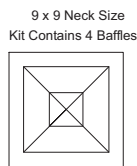

Kit Contains 8 Baffles  
12 x 12 Neck Size

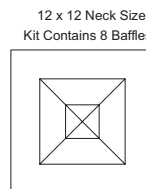

Kit Contains 12 Baffles  
18 x 18 Neck Size

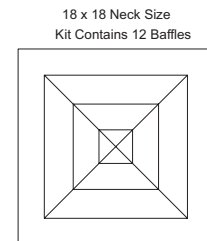

Blank off kits contain sufficient number of baffles to blank off entire neck area of diffuser. Only that number of baffles should actually be used to either blank off sections to create 1, 2 or 3 way air patterns instead of standard 4-way pattern or reduce neck area around entire perimeter (inner or outer ring) for reduced air flow.

\*Actual neck opening is 6" x 6" (155 x 155) on 9" x 9" (228 x 228) diffuser.

Models	Listed Size	Collar		Face (A)	Ceiling Opening (D)
	Neck/Face	Inside (B)	Neck (C)		
5000-1	9" x 9"/12" x 12" (228 x 228/300 x 300)	8 7/8" x 8 7/8" (225 x 225)	9 1/8" x 9 1/8" (231 x 231)	11 5/8" x 11 5/8" (295 x 295)	9 1/4 (235)
	12" x 12"/18" x 18" (300 x 300/455 x 455)	11 7/8" x 11 7/8" (300 x 300)	12 1/8" x 12 1/8" (308 x 308)	17 9/16" x 17 9/16" (446 x 446)	14 3/4 (375)
	18" x 18"/24" x 24" (455 x 455/600 x 600)	17 3/4" x 17 3/4" (450 x 450)	18" x 18" (455 x 455)	23 3/4" x 23 3/4" (603 x 603)	20 11/16 (525)
5000-6	9" x 9"/12" x 12" (228 x 228/300 x 300)	8 7/8" x 8 7/8" (225 x 225)	9 1/8" x 9 1/8" (231 x 231)	11 5/8" x 11 5/8" (295 x 295)	9 1/4 (235)
	18" x 18"/24" x 24" (455 x 455/600 x 600)	17 3/4" x 17 3/4" (450 x 450)	18" x 18" (231 x 231)	23 3/4" x 23 3/4" (603 x 603)	20 11/16 (525)

1. Available Finishes	2. Available Accessories	3. Construction Details
Standard Finish: 01 White	<b>Square and Rectangular Neck:</b> EPTR - Polymer Square to Round Transition EP-OBDS - Polymer Opposed Blade Damper TREP - Aluminum Square to Round Transition TREP - Deep Aluminum or Polymer Square to Round Transition	<ul style="list-style-type: none"> <li>Sizes Available only as listed</li> <li>White finish is through-color Matte white (not Painted)</li> </ul>

## Series EP5000 - Performance

### Models EP5000 (-1, -6)

Neck Size Inches (mm)	Neck Vel. fpm (M/s)	300 (1.5)	400 (2.0)	500 (2.5)	600 (3.0)	700 (3.5)
	Pt Inches (Pa)	0.036 (9)	0.060 (15)	0.092 (23)	0.133 (33)	0.173 (4.3)
6" x 6" (150 x 150)	CFM (Ls)	72 (34)	95 (45)	119 (56)	144 (68)	167 (79)
	Throw Max. Ft. (M)	5 (1.5)	7 (2.0)	8 (2.5)	10 (3.0)	12 (3.5)
	Throw Min. Ft. (M)	3 (1.0)	3 (1.0)	5 (1.5)	5 (1.5)	7 (2.0)
	NC	-	-	-	-	19
12" x 12" (150 x 150)	CFM (Ls)	286 (135)	381 (180)	477 (225)	572 (270)	668 (315)
	Throw Max. Ft. (M)	8 (2.5)	12 (3.5)	15 (4.5)	16 (5.0)	20 (6.0)
	Throw Min. Ft. (M)	5 (1.5)	7 (2.0)	7 (2.0)	8 (2.5)	10 (3.0)
	NC	-	21	26	31	34
18" x 18" (150 x 150)	CFM (Ls)	644 (304)	858 (405)	1073 (504)	1288 (608)	1502 (709)
	Throw Max. Ft. (M)	13 (4.0)	16 (5.0)	21 (6.5)	26 (8.0)	30 (9.0)
	Throw Min. Ft. (M)	7 (2.0)	8 (2.5)	8 (2.5)	13 (4.0)	15 (4.5)
	NC	23	30	35	38	42

### Series EP5000 - Performance Notes:

All data are tested in accordance with ANSI/ASHRAE 70-1991  
 Throw distances are rounded to the nearest foot or one half meter.  
 Throws are based on 4-way air pattern and terminal velocities for a maximum throw of 80 fpm (0.4 M/s) and for a minimum throw of 120 fpm (0.61 M/s).

NC is based on 10 dB room absorption.

Pt is the total pressure drop across the diffuser in inches W.G. (Pa) = Pst + Pv.

Ps is static pressure in inches W.G.

Neck sizes are nominal in inches and millimeters.

For directional throws, reduce the CFM (Ls) by the following percentages:

3-Way - Reduce airflow by 25%; all other values unchanged.

2-Way - Reduce airflow by 50%; all other values unchanged.

1-Way - Reduce airflow by 75%; all other values unchanged.

### Definition of Units:

Ls - Liters per second

CFM - Ls/0.4719

Pa - Pascal

Inch of W.G. - Pa/249

M/s - Meters per second

fpm - Feet per minute (M/s x 197)

mm - millimeters

mm - Inches x 25.4

\* - Pressure drop less than 0.001

-- - NC less than 15

Correction factors for 45° blade deflection:

Throw x 0.55 NC + 8 dB Ps x 3.1



## Series EP5000 - Specifications

### Supply Square Louvered Face - Engineered Polymer Ceiling Diffusers

EP5000-1 - *Surface Mounted*

EP5000-6 - *T-bar Lay-in*

Air Outlets shall be engineered polymer model EP5000 provided by METALAIRE. Units shall consist of a fixed 4 way pattern louvered core fastened into a border. Border shall be molded in a single piece eliminating corner seams. Louvered core shall be fastened with integral clips and be removable from the face. Units shall include a mounting bracket assemble, accessible by removing the face.

Outlets shall be engineered for high capacity applications and include straight deflector blades (without a horizontal lip). Units with a horizontal lip at the ends of the deflector blades are not acceptable. The units shall be the size and quantity as outline in the plans and specifications.

Units shall be constructed entirely of rigid injection molded engineered polymer. The material shall be ultraviolet light stable and shall not become brittle with age. Units shall allow cleaning with commercial solvents, in a dishwasher, or steam cleaned without damaging the product.

The engineered polymer shall be tested in an independent laboratory. Units shall be NFPA standard 90A and 90B compliant. Units shall also be UL 94V rated with a flame spread of 0 and a smoke development rating of 35.

Units shall be designed to integrate into the specified ceiling system.

### Performance Specification

The manufacturer shall provide published performance data. Data shall be tested in accordance to ANSI/ASHRAE Standard 70-1991.

### Optional Dampers

Engineered Polymer opposed blade dampers shall be provided. Damper shall be lever operated through the face of the diffuser.



## Series EP5000 - Model Specification Guide

### Square Louver Face Ceiling Diffusers Model EP5000-1 - Flush Surface Mount

Model	Available Neck		Air Pattern	Available Finishes	Available Options	
5000-1 - Flush Surface Mount	9"	9"	Standard	Standard	EP-OBD5	Opposed Blade Damper - Polymer
	12"	12"	S4-Sq - 4-Way	01 - White		
	18"	18"				

### Square Louver Face Ceiling Diffusers Model EP5000-6 - T-Bar Lay-In

Model	Available Neck		Available Neck	Air Pattern	Available Finishes	Available Options	
5000-6 - T-bar Lay-in	18"	18"	24" x 24"	Standard	Standard	EP-OBD5	Oppose Blade Damper - Polymer
				S4-Sq - 4-Way	01 - White		



## ➔ Engineered Polymer Cube Core ➔ Eggcrate Return/Exhaust ➔ Series EPCC5

### Product Details

- ★ Attractive 1/2" x 1/2" grid by 1/2" deep design
- ★ Available for non-ducted applications
- ★ Can be used with an aluminum transition for use with round duct.

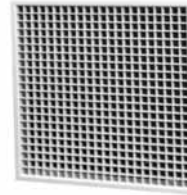

### Model EPCC5 Shown

Standard Finish: 01 White

Dimensions are in inches

**Engineered Polymer Grilles and Registers - Eggcrate Return/Exhaust**  
 Series EP-CC5 - 1/2" x 1/2" x 1/2" - Surface Mount  
 Model EP-CC5-1 - Cube Core Grille

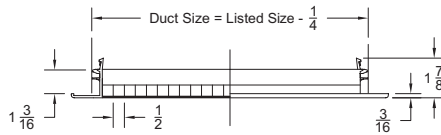

**Engineered Polymer Cube Core Registers - Eggcrate Return/Exhaust**  
 Series EP-CC5 - 1/2" x 1/2" x 1/2" - Surface Mount  
 Model EP-CC5D-1 - Damper

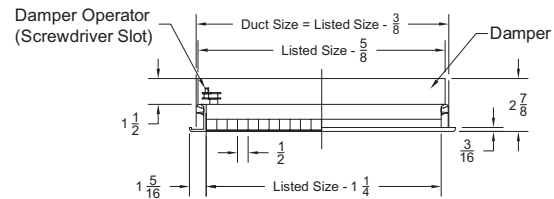

**Engineered Polymer Cube Core Grille - Eggcrate Return/Exhaust**  
 Series EP-CC5DP-1 - 1/2" x 1/2" x 1/2" - Surface Mount  
 Model EP-CC5DP-1 - Polymer Damper

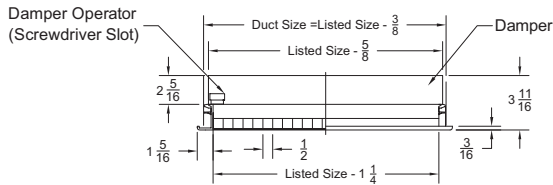

Engineered Polymer Products



EPP

# EPP - Engineered Polymer Products

**Engineered Polymer Grilles and Registers - Eggcrate Return/Exhaust**  
 Series EP-CC5 - 1/2" x 1/2" x 1/2" - Surface Mount  
 Model EP-CC5-1 - *Cube Core Grille*

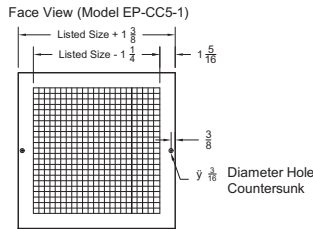

**Engineered Polymer Cube Core Registers - Eggcrate Return/Exhaust**  
 Series EP-CC5 - 1/2" x 1/2" x 1/2" - Surface Mount  
 Model EP-CC5D-1 - *Damper*

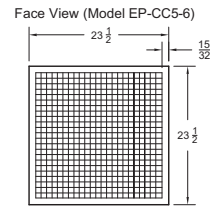

1. Available Finishes	2. Available Accessories	3. Construction Details
Standard Finish: 01 White	Shipped Unattached EP-OBDD - Polymer Opposed Blade Damper (For Grille)	<ul style="list-style-type: none"> <li>Sizes Available only as listed</li> <li>White finish is through-color Matte white (not Painted)</li> </ul>

## Series EPCC5 - Performance

### Models EPCC5 (-1)

Flow Rate CFM (Ls)		Size Inches (mm)					
		6" x 6" (150 x 150)	8" x 8" (200 x 200)	10" x 10" (250 x 250)	12" x 6" (300 x 150)	12" x 12" (300 x 300)	23" x 23" (584 x 584)
52 (25)	Ps Inches (Pa) NC	0.008 (2) -	0.004 (1) -				
106 (50)	Ps Inches (Pa) NC	0.032 (8) -	0.008 (2) -	0.004 (1) -	0.008 (2) -		
212 (100)	Ps Inches (Pa) NC	0.125 (32) 28	0.036 (9) 18	0.016 (4) -	0.028 (7) -	0.008 (2) -	
318 (150)	Ps Inches (Pa) NC		0.060 (15) 28	0.032 (8) 18	0.060 (15) 23	0.016 (4) -	
424 (200)	Ps Inches (Pa) NC		0.161 (40) 36	0.060 (15) 25	0.108 (27) 33	0.028 (7) 15	.002 (.5) -
530 (250)	Ps Inches (Pa) NC		0.241 (60) 42	0.088 (22) 30	0.173 (43) 37	0.044 (11) 22	.004 (1) -
636 (300)	Ps Inches (Pa) NC			0.120 (30) 35	0.241 (62) 42	0.052 (13) 27	.006 (1.5) -
848 (400)	Ps Inches (Pa) NC			0.241 (60) 43	* -	0.108 (27) 35	0.10 (2.5) -
1060 (500)	Ps Inches (Pa) NC					0.160 (40) 41	.016 (4) -

See Page EPP-306 for Performance Notes





## Series EPCC5 - Performance Notes:

### Series EPCC5 - Performance Notes:

All data are tested in accordance with ANSI/ASHRAE 70-1991  
Throw distances are rounded to the nearest foot or one half meter.  
Throws are based on 4-way air pattern and terminal velocities for a maximum throw of 80 fpm (0.4 M/s) and for a minimum throw of 120 fpm (0.61 M/s).

NC is based on 10 dB room absorption.

Pt is the total pressure drop across the diffuser in inches W.G.  $(Pa) = Ps + Pv$ .

Ps is static pressure in inches W.G.

Neck sizes are nominal in inches and millimeters.

For directional throws, reduce the CFM (Ls) by the following percentages:

3-Way - Reduce airflow by 25%; all other values unchanged.

2-Way - Reduce airflow by 50%; all other values unchanged.

1-Way - Reduce airflow by 75%; all other values unchanged.

### Definition of Units:

Ls	-	Liters per second
CFM	-	Ls/0.4719
Pa	-	Pascal
Inch of W.G.	-	Pa/249
M/s	-	Meters per second
fpm	-	Feet per minute (M/s x 197)
mm	-	millimeters
mm	-	Inches x 25.4
*	-	Pressure drop less than 0.001
--	-	NC less than 15

Correction factors for 45° blade deflection:

Throw x 0.55 NC + 8 dB Ps x 3.1

## Series EPCC5 - Specifications

### Return/Exhaust Grilles - Engineered Polymer

EP-CC5-1 - *Surface Mounted*

Air Inlets shall be model EP-CC5 provided by METALAIRE. Units shall have a 1/2" x 1/2" x 1/2" cubed core. Units shall be return or exhaust grilles constructed of an engineered polymer single piece molded border. The units shall be the size and quantity as outline in the plans and specifications.

Units shall be constructed entirely of rigid injection molded engineered polymer. The material shall be ultraviolet light stable and shall not become brittle with age. Units shall allow cleaning with commercial solvents, in a dishwasher, or steam cleaned without damaging the product.

The engineered polymer shall be tested in an independent laboratory. Units shall be NFPA standard 90A and 90B compliant. Units shall also be UL 94V rated with a flame spread of 0 and a smoke development rating of 35.

Units shall be designed to integrate into the specified ceiling system or wall mounting application.

### Optional Dampers

Engineered Polymer opposed blade dampers shall be provided. Damper shall be lever operated through the face of the diffuser.

### Performance Specification

The manufacturer shall provide published performance data. Data shall be tested in accordance to ANSI/ASHRAE Standard 70-1991.



## Series EPCC5 - Model Specification Guide

Return Exhaust - Cubed Core - Sidewall/Ceiling  
 Model EPCC5-1 - 1/2" x 1/2" x 1/2" Cube Core

Model	Available Neck		Available Finishes	Available Options	
EP-CC5-1 - 1/2" x 1/2" x 1/2" Cube Core	6"	6"	Standard	EP-OBD	Opposed Blade Damper
	8"	8"	01 - White		
	12"	12"			
	12"	6"			
	12"	12"			
	22"	22"			



## ↳ Louver Face Return/Exhaust ↳ Series EPRH

### Product Details

- ★ Fixed 45° angled deflecting blades provide a vision obscured appearance
- ★ Horizontal 45° angled fixed vanes are on 3/4" centers



**Model EPRH Shown**

Standard Finish: 01 White

Dimensions are in inches

**Engineered Polymer Grille - Louver Face Return/Exhaust**  
**Series EPRH - Surface Mount**  
 Model EPRH-1 - 45° Fixed Blades

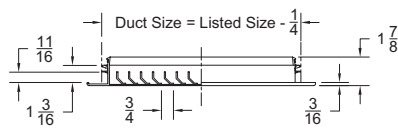

**Engineered Polymer Register with Aluminum Damper - Louver Face Return/Exhaust**  
**Series EPRH - Surface Mount**  
 Model EPRHD-1 - 45° Fixed Blades

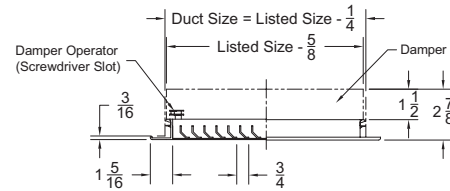

**Engineered Polymer Grille with Polymer Damper - Louver Face Return/Exhaust**  
**Series EPRHDP-1 - Surface Mount**  
 Model EPRHDP-1 - 45° Fixed Blades

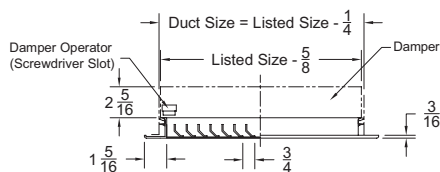

**Engineered Polymer Grilles and Registers - Louver Face Return/Exhaust**  
**Series EPRH - Face View (All models)**

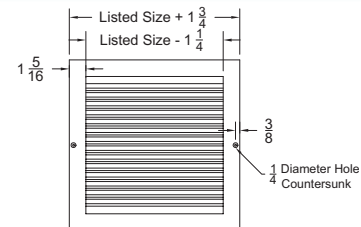

Engineered Polymer Products



EPP

1. Available Finishes	2. Available Accessories	3. Construction Details
Standard Finish: 01 White	EP-OBDD - Polymer Opposed Blade Damper (For Grille)	<ul style="list-style-type: none"> <li>Sizes Available only as listed</li> <li>White finish is through-color Matte white (not Painted)</li> </ul>

## Series EPCC5 - Performance

### Model EPRH-1

Flow Rate CFM (Ls)		Size Inches (mm)				
		6" x 6" (150 x 150)	8" x 8" (200 x 200)	10" x 10" (250 x 250)	12" x 6" (300 x 150)	12" x 12" (300 x 300)
52	Ps Inches (Pa)	0.028 (7)	0.008 (2)	*	0.004 (1)	
(25)	NC	-	-	-	-	
106	Ps Inches (Pa)	0.108 (27)	0.040 (10)	0.016 (4)	0.024 (6)	
(50)	NC	20	-	-	-	
212	Ps Inches (Pa)		0.140 (35)	0.060 (15)	0.108 (27)	0.028 (7)
(100)	NC		-	-	-	-
318	Ps Inches (Pa)			0.120 (30)	0.221 (55)	0.060 (15)
(150)	NC			27	34	19
424	Ps Inches (Pa)			0.060 (15)	0.402 (100)	0.100 (25)
(200)	NC			25	42	27
530	Ps Inches (Pa)					0.153 (38)
(250)	NC					32
636	Ps Inches (Pa)					0.201 (50)
(300)	NC					36

### Series EPRH - Performance Notes:

All data are tested in accordance with ANSI/ASHRAE 70-1991  
 Throw distances are rounded to the nearest foot or one half meter.  
 Throws are based on 4-way air pattern and terminal velocities for a maximum throw of 80 fpm (0.4 M/s) and for a minimum throw of 120 fpm (0.61 M/s).

NC is based on 10 dB room absorption.

Pt is the total pressure drop across the diffuser in inches W.G. (Pa) = Ps + Pv.  
 Ps is static pressure in inches W.G.

Neck sizes are nominal in inches and millimeters.

For directional throws, reduce the CFM (Ls) by the following percentages:

- 3-Way - Reduce airflow by 25%; all other values unchanged.
- 2-Way - Reduce airflow by 50%; all other values unchanged.
- 1-Way - Reduce airflow by 75%; all other values unchanged.

### Definition of Units:

- Ls - Liters per second
- CFM - Ls/0.4719
- Pa - Pascal
- Inch of W.G. - Pa/249
- M/s - Meters per second
- fpm - Feet per minute (M/s x 197)
- mm - millimeters
- mm - Inches x 25.4
- \* - Pressure drop less than 0.001
- - NC less than 15

Correction factors for 45° blade deflection:  
 Throw x 0.55 NC + 8 dB Ps x 3.1



## Series EP-RH - Specifications

### **Return Grilles - Engineered Polymer**

EPRH-1 – *Surface Mounted*

Air Inlets shall be model EP-RH provided by METALAIRE. Units shall be return or exhaust grilles constructed of an engineered polymer single piece molded border and a single set of fixed deflection blades. The units shall be the size and quantity as outline in the plans and specifications.

Units shall be constructed entirely of rigid injection molded engineered polymer. The material shall be ultraviolet light stable and shall not become brittle with age. Units shall allow cleaning with commercial solvents, in a dishwasher, or steam cleaned without damaging the product.

The engineered polymer shall be tested in an independent laboratory. Units shall be NFPA standard 90A and 90B compliant. Units shall also be UL 94V rated with a flame spread of 0 and a smoke development rating of 35.

Units shall be designed to integrate into the specified ceiling system.

### **Performance Specification**

The manufacturer shall provide published performance data. Data shall be tested in accordance to ANSI/ASHRAE Standard 70-1991.

### **Optional Dampers**

Engineered Polymer opposed blade dampers shall be provided. Damper shall be lever operated through the face of the diffuser.



## Series EP-RH - Model Specification Guide

Sidewall Return Grille - Horizontal Blades

Model EP-RH-1 - Louver Grille for Surface Mounting

Model	Available Neck		Available Finishes	Available Options	
EP-RH-1	6"	6"	Standard	EP-OBD	Opposed Blade Damper
	8"	8"	01 - White		
	10"	10"			
	12"	6"			
	12"	12"			



# LEADING THE INDUSTRY IN PRODUCT LITERATURE

With the choice of our Pre-Flite Catalog, Quick Select Catalog, InfoSource Catalog, InfoSource CD and our web site, [www.metalaire.com](http://www.metalaire.com), you pick the format for product information that best suits your air distribution design needs.

## Pre-Flite - Product Overview Catalog

The METALAIRE Pre-Flite catalog is a condensed reference guide containing concise listings of our entire product line including grilles, registers, diffusers, and air terminal units. This catalog can be used to help select the type of device, along with available border styles. The catalog includes photos of each model along with the features and model guide, a great tool when you are trying to select a device for your project.



## Quick Select Catalog - Air Distribution Selection Made Easy

The METALAIRE Quick Select Catalog is designed to save you time selecting air distribution equipment. This catalog is a compact version of our InfoSource Catalogs and includes drawings and performance for our most popular products. The Quick Select Catalog is broken into product types with each section beginning with a model summary that includes features and benefits of our products. To obtain product information not included in the Quick Select Catalog, simply go to our web site at [www.metalaire.com](http://www.metalaire.com).



## InfoSource Catalog Suite - Complete guide to Air Distribution Selection

The METALAIRE InfoSource Catalog suite is the leading product catalog in the industry. Included in these catalogs are the complete product listings, drawings, product features and benefits, product performance data, specifications, and model specifications. These catalogs are organized to make it quick and easy to find the information you are looking for.

### InfoSource Catalog Suite

- Ceiling Diffusers Catalog
- Grilles & Registers Catalog
- Air Terminal Unit Catalog
- Formations Catalog



## InfoSource CD

Our InfoSource CD has set the standard in the industry for air distribution product selection. This CD contains a complete library of all our catalogs and submittals along with our air terminal unit selection program.



## Web Site: [www.metalaire.com](http://www.metalaire.com)

METALAIRE leads the industry with a web site that contains all the product literature and performance data needed to design your air distribution system. Our web site includes all our submittals, catalogs, installation manuals, as well as as other valuable information to aid you in air distribution design.



**METALAIRE**  
EXPERIENCE AIRE SUPERIORITY.

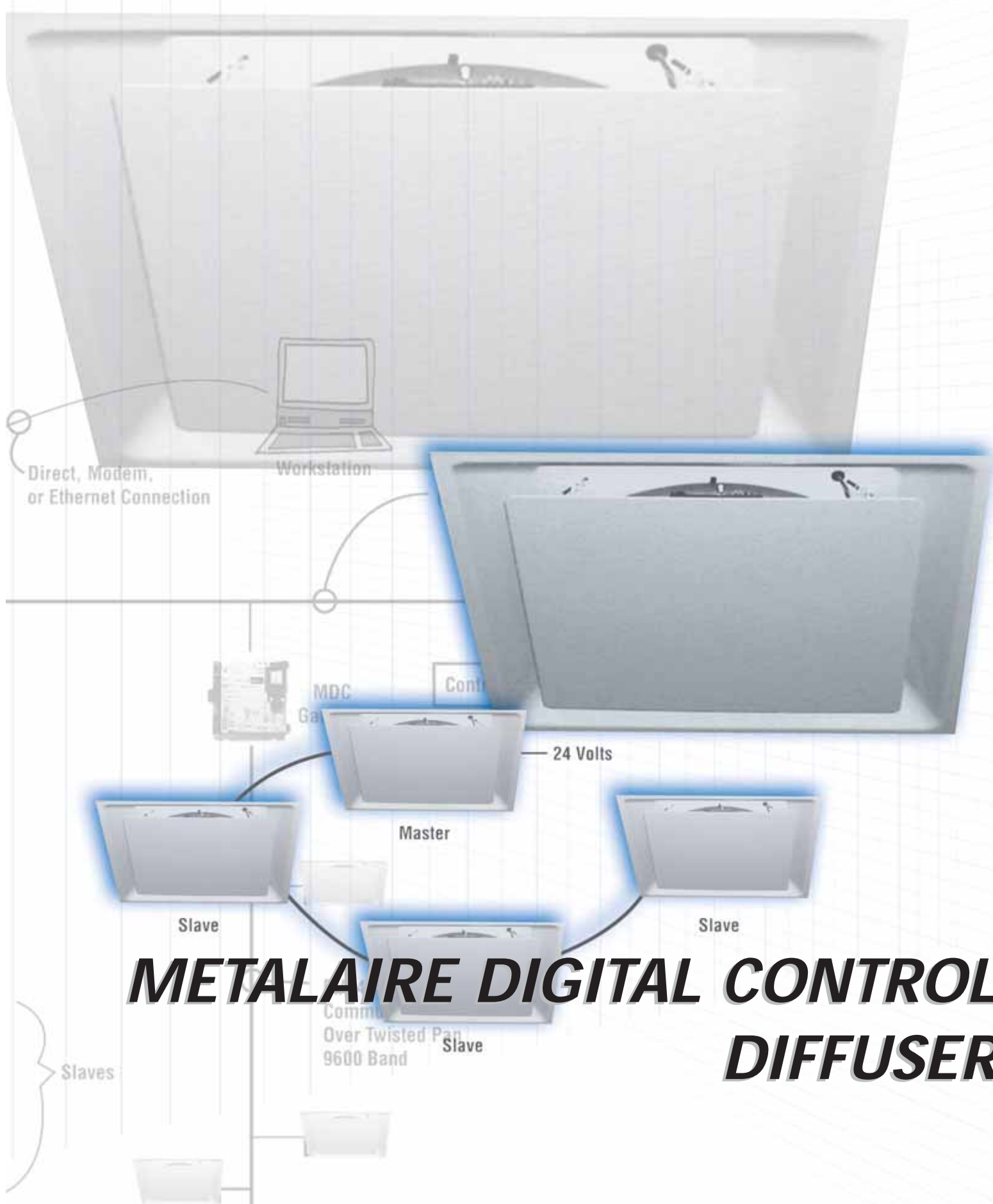

***METALABRE DIGITAL CONTROL DIFFUSER***



# LEADING THE INDUSTRY IN PRODUCT LITERATURE

With the choice of our Pre-Flite Catalog, Quick Select Catalog, InfoSource Catalog, InfoSource CD and our web site, [www.metalaire.com](http://www.metalaire.com), you pick the format for product information that best suits your air distribution design needs.

## Pre-Flite - Product Overview Catalog

The METALAIRE Pre-Flite catalog is a condensed reference guide containing concise listings of our entire product line including grilles, registers, diffusers, and air terminal units. This catalog can be used to help select the type of device, along with available border styles. The catalog includes photos of each model along with the features and model guide, a great tool when you are trying to select a device for your project.



## Quick Select Catalog - Air Distribution Selection Made Easy

The METALAIRE Quick Select Catalog is designed to save you time selecting air distribution equipment. This catalog is a compact version of our InfoSource Catalogs and includes drawings and performance for our most popular products. The Quick Select Catalog is broken into product types with each section beginning with a model summary that includes features and benefits of our products. To obtain product information not included in the Quick Select Catalog, simply go to our web site at [www.metalaire.com](http://www.metalaire.com).



## InfoSource Catalog Suite - Complete guide to Air Distribution Selection

The METALAIRE InfoSource Catalog suite is the leading product catalog in the industry. Included in these catalogs are the complete product listings, drawings, product features and benefits, product performance data, specifications, and model specifications. These catalogs are organized to make it quick and easy to find the information you are looking for.

### InfoSource Catalog Suite

- Ceiling Diffusers Catalog
- Grilles & Registers Catalog
- Air Terminal Unit Catalog
- Formations Catalog



## InfoSource CD

Our InfoSource CD has set the standard in the industry for air distribution product selection. This CD contains a complete library of all our catalogs and submittals along with our air terminal unit selection program.



## Web Site: [www.metalaire.com](http://www.metalaire.com)

METALAIRE leads the industry with a web site that contains all the product literature and performance data needed to design your air distribution system. Our web site includes all our submittals, catalogs, installation manuals, as well as as other valuable information to aid you in air distribution design.



## METALAIRE Digital Control Diffuser - Introduction

*The METALAIRE MDC diffusers is engineered to provide a high induction/high performance diffuser with microprocessor based, direct digital control.*

*The diffuser maximizes comfort in both heating and cooling conditions. The MDC provides all the power you would expect from a VAV box controller with the added advantage of providing superior room air induction and higher levels of occupant comfort. The MDC also allows for smaller zone design leading directly to happier building occupants and increased office productivity.*

*The power of the MDC Diffuser is not only the on-board electronics but also the high induction characteristic of the unit. As the amount of required air is reduced, the damper of the MDC begins to close. This increases the discharge velocity of the supply air leading directly to increased air throw distance and total air induction. Higher induction means better comfort.*

*Each master unit can control up to three slave units giving the HVAC designer a wide range of options when laying out air distribution zones in a building. A highly reliable wax actuator for precision control powers the MDC damper. The wax actuator is maintenance free and provides ultra quiet operation.*

The MDC can be setup and operated using the METALAIRE HHC – Hand Held Control Unit. The handheld remote uses bi-directional infrared (IR) communications and supports two modes: user and installer. In the user mode, the room occupant can use the HHC to adjust the heating and cooling set point. In the password protected installer mode, the HHC has the power to fully configure and control the diffuser. Built into the HHC

are easy to follow labels for the installer and building operator.

The diffuser has on-board intelligence that monitors the room temperature, the supply air temperatures and varies the volume of supply air to provide the highest level of occupant comfort.

The MDC diffuser has the built in ability to function as a stand-alone device or expand to integrate into a large building control system communicating over a wide area network. A network of MDC diffusers can communicate by BACnet MS/TP with the MDC gateway. The diffuser can talk to any building automation control systems using BACnet, Modbus, Lonworks, or Johnson N2. The MDC diffuser is support with high-powered system tools including the METALAIRE Gateway and the METALAIRE Portal Device.

The MDC Diffuser is your solution to improved comfort and productivity whether your building requires one diffuser to take care of a problem zone or multiple diffusers to provide comfort to a worldwide operation.

Another advantage of the MDC diffuser is that the room sensor and the associated installation costs can be eliminated. The diffuser has a built in sensor that accurately measures room temperature.



## MDC Features

### Superior personal comfort

The main function of an air distribution system is to provide comfort to a building's occupants. The MDC is an economical solution to maximize personal comfort by allowing smaller zone control. MDC diffuser installed in an individual's office gives the occupant the ability to set the temperature for both heating and cooling comfort.

This diffuser is also an excellent choice for large open office areas. By using a master unit along with 3 slave diffusers, the MDC can cut large work spaces into small occupant zones maximizes comfort and increasing productivity.

### Flexibility

The MDC has the flexibility to operate in applications ranging from office buildings, retail stores, schools, hospitals, and conference centers. Flexibility built into the MDC allows the diffuser to be applied to a wide range of applications providing superior control and occupant comfort.

### Expandability

The MDC has the power and expandability to operate stand-alone or communicate on a wide area network. As a native BACnet device, the MDC can start as a stand-alone unit to control the temperature in a single zone. By adding a communication link, the expansion of the system is unlimited.

### Interoperability

All MDC diffusers are native BACnet devices and communicate using MS/TP protocol. These devices can communicate to any BACnet system regardless of system manufacturer giving building owners and operators the freedom to select and change building controls even after the system is installed. Using the METALAIRE Portal, the MDC diffusers can be set-up to communicate with Modbus or Johnson Control's N2 protocol. With the addition of a Serial LonTalk Adapter, the MDC can be integrated into a Lon system.

### Ease of Installation

Installation of the MDC is quick and easy. In the basic configuration, the MDC only requires a 24 power connection and the unit will begin operation as a stand alone device. Add a twisted pair connection and you now can communicate over a multitude of building automation systems.

### Ease of Start-up, Operation, and Trouble Shooting

The MDC is easy to configure using the HHC hand held control. The HHC uploads all the operation functions for the MDC operation. Built into each controller are LEDs designed to make trouble shooting easy. Installers and building operators from the floor can the LEDs indicating normal operation, transferring firmware, auto-detecting baud rate, hardware failure, manual mode, and firmware error. Indicators also show TX transmit and RX receive displays.

### Economic Alternative to a conventional VAV system

When looking at the MDC diffuser, one must consider the cost compared to a conventional system. The MDC first costs are comparable to a conventional system when the entire installation labor and control wiring is considered.



## ➔ Digital Controlled Diffuser ➔ Series MDC ➔ Steel

### Product Details

#### ✦ Superior Personal Comfort

The main function of an air distribution system is to provide comfort to a building's occupants. The MDC® is an economical solution to maximize personal comfort by allowing smaller zone control. An MDC® diffuser installed in an individual's office gives the occupant the ability to set the temperature for both heating and cooling comfort

#### ✦ Flexibility

The MDC® has the flexibility to operate in applications ranging from office buildings, retail stores, schools, hospitals, and conference centers. Flexibility built into the MDC® allows the diffuser to be applied to a wide range of applications providing superior control and occupant comfort

#### ✦ Interoperability

All MDC® diffusers are native BACnet devices and communicate using MS/TP protocol. These devices can communicate to any BACnet system regardless of system manufacturer giving building owners and operators the freedom to select and change building controls even after the system is installed. Using the METALAIRE® Portal, the MDC® diffusers can be set-up to communicate with Modbus or Johnson Control's N2 protocol. With the addition of a Serial LonTalk adapter, the MDC® can be integrated into a Lon system

#### ✦ Ease of Installation

Installation of the MDC® is quick and easy. In the basic configuration, the MDC® only requires a 24 power connection and the unit will begin operation as a stand alone device. Add a twisted pair connection and you now can communicate over a multitude of building automation systems

#### ✦ Ease of Start-up, Operation, and Trouble Shooting

The MDC® is easy to configure using the HHC hand held control. The HHC uploads all the operation functions for the MDC® operation. Built into each controller are LEDs designed to make trouble shooting easy. Installers and building operators from the floor can view the LEDs indicating normal operation, transferring firmware, auto-detecting baud rate, hardware failure, manual mode, and firmware error. Indicators also show TX transmit and RX receive displays

#### ✦ Economic Alternative to a Conventional VAV System

When looking at the MDC® diffuser, one must consider the cost compared to a conventional system. The initial cost of an MDC® system is comparable to a conventional system when the entire installation, labor and control wiring is considered

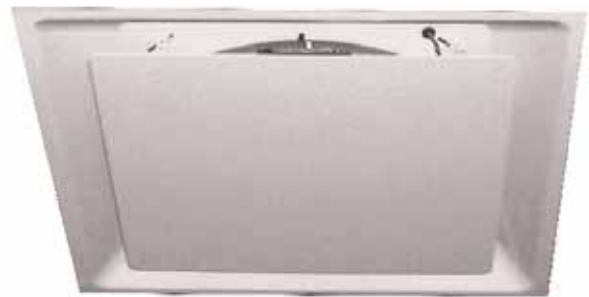

**Model MDC Shown**

Standard Finish: 01 White

# 8/2006 MDC - METALAIRE Digital Control Diffuser

Dimensions are in inches

**Digital Controlled Diffuser - Steel**  
18" x 18" Square Bottom Panel  
Model MDC-1 - Surface Mount

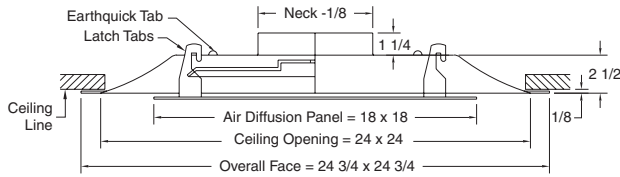

**Digital Controlled Diffuser - Steel**  
18" x 18" Square Bottom Panel  
Model MDC-6 - T-bar Lay-in

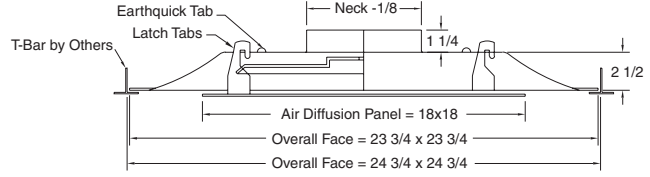

1. Available Finishes	2. Available Accessories	3. Available Options	4. Construction Details
Standard Finish: 01 White	HHC - Hand held controller MDC-G - MDC Gateway	120/24 - Volt Transformer 240/24 - Volt Transformer 277/24 - Volt Transformer 120/277/24 - Dual Voltage Transformer	<ul style="list-style-type: none"> <li>MDC diffuser is shipped with all components and wiring harnesses required for installation</li> <li>Requires the additional of the HHC hand held remote to set-up and operate the MDC Diffusers</li> </ul>

## Model MDC - Performance

Damper Percent Open		20	30	40	50	60	70	80	90	100	
6"	Inlet Static Pressure 0.1	Airflow Rate, CFM Velocity Pressure, in. w.c. Total Pressure, in. w.c. NC Throw	45 0.003 0.103 <15 1-2-4	60 0.006 0.106 <15 1-2-4	75 0.009 0.109 16 2-2-5	85 0.012 0.112 16 2-2-5	95 0.015 0.115 17 2-2-5	105 0.018 0.118 18 2-3-5	115 0.021 0.121 18 2-3-5	125 0.025 0.125 19 2-3-5	135 0.029 0.129 19 2-3-5
	Inlet Static Pressure 0.2	Airflow Rate, CFM Velocity Pressure, in. w.c. Total Pressure, in. w.c. NC Throw	80 0.010 0.210 20 2-4-6	100 0.016 0.216 21 2-4-6	120 0.023 0.223 22 3-4-7	135 0.029 0.229 22 3-4-7	150 0.036 0.236 23 3-4-8	165 0.044 0.244 24 3-4-8	180 0.052 0.252 24 3-4-8	190 0.058 0.258 24 3-4-8	205 0.068 0.268 25 3-4-8
	Inlet Static Pressure 0.3	Airflow Rate, CFM Velocity Pressure, in. w.c. Total Pressure, in. w.c. NC Throw	90 0.013 0.313 23 3-4-6	115 0.021 0.321 25 3-4-7	140 0.032 0.332 26 3-4-8	160 0.041 0.341 27 3-5-8	185 0.055 0.355 28 3-5-9	205 0.068 0.368 29 3-5-9	220 0.078 0.378 29 3-5-9	240 0.093 0.393 30 3-5-10	255 0.105 0.405 30 3-5-10
	Inlet Static Pressure 0.4	Airflow Rate, CFM Velocity Pressure, in. w.c. Total Pressure, in. w.c. NC Throw	105 0.018 0.418 25 3-5-7	140 0.032 0.432 27 3-5-8	165 0.044 0.444 29 4-5-8	195 0.061 0.461 31 4-6-9	215 0.075 0.475 32 4-6-9	240 0.093 0.493 33 4-6-10	265 0.114 0.514 34 4-6-10	285 0.131 0.531 35 4-6-11	305 0.150 0.550 36 4-6-11
	Inlet Static Pressure 0.5	Airflow Rate, CFM Velocity Pressure, in. w.c. Total Pressure, in. w.c. NC Throw	120 0.023 0.523 30 4-5-7	155 0.039 0.539 32 4-6-8	190 0.058 0.558 34 4-6-9	220 0.078 0.578 35 4-6-9	245 0.097 0.597 36 4-6-10	275 0.122 0.622 37 4-7-11	300 0.146 0.646 37 5-7-11	320 0.166 0.666 38 5-7-11	345 0.192 0.692 38 5-7-12

Damper Percent Open		20	30	40	50	60	70	80	90	100	
8"	Inlet Static Pressure 0.1	Airflow Rate, CFM Velocity Pressure, in. w.c. Total Pressure, in. w.c. NC Throw	50 0.001 0.101 16 1-2-4	65 0.002 0.102 16 1-2-4	85 0.004 0.104 17 2-2-5	100 0.005 0.105 17 2-2-5	115 0.007 0.107 18 2-3-5	130 0.009 0.109 18 2-3-5	145 0.011 0.111 19 2-3-6	160 0.013 0.113 20 2-3-6	170 0.015 0.115 20 2-3-6
	Inlet Static Pressure 0.2	Airflow Rate, CFM Velocity Pressure, in. w.c. Total Pressure, in. w.c. NC Throw	80 0.003 0.203 25 2-3-6	110 0.006 0.206 26 2-4-7	135 0.009 0.209 26 2-4-7	155 0.012 0.212 27 3-4-8	180 0.017 0.217 27 3-4-8	200 0.020 0.220 27 3-4-8	220 0.025 0.225 28 3-4-9	235 0.028 0.228 28 3-4-9	255 0.033 0.233 28 3-4-9
	Inlet Static Pressure 0.3	Airflow Rate, CFM Velocity Pressure, in. w.c. Total Pressure, in. w.c. NC Throw	95 0.005 0.305 29 2-4-6	130 0.009 0.309 30 3-4-7	160 0.013 0.313 31 3-4-8	190 0.018 0.318 31 3-5-9	220 0.025 0.325 32 3-5-9	245 0.031 0.331 32 3-5-10	270 0.037 0.337 33 4-5-10	295 0.045 0.345 33 4-5-11	320 0.052 0.352 33 4-6-11
	Inlet Static Pressure 0.4	Airflow Rate, CFM Velocity Pressure, in. w.c. Total Pressure, in. w.c. NC Throw	120 0.007 0.407 32 3-5-7	160 0.013 0.413 33 3-5-8	195 0.019 0.419 34 4-5-9	230 0.027 0.427 35 4-6-10	265 0.036 0.436 36 4-6-10	295 0.045 0.445 37 4-6-11	325 0.054 0.454 38 4-6-11	355 0.064 0.464 38 4-7-12	385 0.076 0.476 39 4-7-12
	Inlet Static Pressure 0.5	Airflow Rate, CFM Velocity Pressure, in. w.c. Total Pressure, in. w.c. NC Throw	125 0.008 0.508 35 3-5-7	175 0.016 0.516 36 4-6-8	220 0.025 0.525 38 4-6-9	260 0.035 0.535 38 4-6-10	300 0.046 0.546 39 5-7-11	335 0.057 0.557 39 5-7-12	370 0.070 0.570 40 5-7-12	405 0.084 0.584 40 5-7-13	440 0.099 0.599 40 5-8-13

For more product information visit us at [www.metalair.com](http://www.metalair.com)

**MDC-317**  
METALAIRE

METALAIRE Digital Control Diffuser



MDC



# MDC - METALAIRE Digital Control Diffuser 8/2006

## Model MDC - Performance

Damper Percent Open		20	30	40	50	60	70	80	90	100	
10"	Inlet Static Pressure 0.1	Airflow Rate, CFM	50	75	95	120	140	160	180	200	220
		Velocity Pressure, in. w.c.	0.001	0.001	0.002	0.003	0.004	0.005	0.007	0.008	0.010
		Total Pressure, in. w.c.	0.101	0.101	0.102	0.103	0.104	0.105	0.107	0.108	0.110
		NC	17	18	19	19	20	21	21	22	22
		Throw	1-2-4	1-2-4	2-2-5	2-3-5	2-3-6	2-3-6	2-3-6	2-3-7	2-3-7
Inlet Static Pressure 0.2	Airflow Rate, CFM	80	115	145	180	210	245	275	305	335	
	Velocity Pressure, in. w.c.	0.001	0.003	0.004	0.007	0.009	0.013	0.016	0.019	0.024	
	Total Pressure, in. w.c.	0.201	0.203	0.204	0.207	0.209	0.213	0.216	0.219	0.224	
	NC	30	30	30	31	31	31	31	32	32	
	Throw	2-3-6	2-3-7	2-4-7	3-4-8	3-4-9	3-5-9	3-5-10	3-5-10	4-5-11	
Inlet Static Pressure 0.3	Airflow Rate, CFM	105	145	190	225	265	305	340	375	410	
	Velocity Pressure, in. w.c.	0.002	0.004	0.008	0.011	0.015	0.019	0.024	0.029	0.035	
	Total Pressure, in. w.c.	0.302	0.304	0.308	0.311	0.315	0.319	0.324	0.329	0.335	
	NC	35	35	36	36	36	36	36	37	37	
	Throw	2-4-7	3-4-8	3-5-9	3-5-10	4-5-10	4-6-11	4-6-12	4-6-12	4-7-13	
Inlet Static Pressure 0.4	Airflow Rate, CFM	130	185	235	280	325	370	415	460	500	
	Velocity Pressure, in. w.c.	0.004	0.007	0.012	0.016	0.022	0.029	0.036	0.044	0.052	
	Total Pressure, in. w.c.	0.404	0.407	0.412	0.416	0.422	0.429	0.436	0.444	0.452	
	NC	39	40	40	41	41	41	42	42	42	
	Throw	3-5-7	4-5-9	4-6-10	4-6-11	4-7-11	5-7-12	5-7-13	5-8-14	5-8-14	
Inlet Static Pressure 0.5	Airflow Rate, CFM	135	195	205	305	360	410	460	510	560	
	Velocity Pressure, in. w.c.	0.004	0.008	0.013	0.019	0.027	0.035	0.044	0.055	0.066	
	Total Pressure, in. w.c.	0.504	0.508	0.513	0.519	0.527	0.535	0.544	0.555	0.566	
	NC	41	41	41	42	42	42	42	43	43	
	Throw	3-5-7	4-6-9	4-6-10	5-7-11	5-7-12	5-8-13	5-8-14	6-9-14	6-9-15	

Damper Percent Open		20	30	40	50	60	70	80	90	100	
12"	Inlet Static Pressure 0.1	Airflow Rate, CFM	50	75	100	125	150	170	195	220	240
		Velocity Pressure, in. w.c.	0.000	0.001	0.001	0.002	0.002	0.003	0.004	0.005	0.006
		Total Pressure, in. w.c.	0.100	0.101	0.101	0.102	0.102	0.103	0.104	0.105	0.106
		NC	19	20	20	21	22	23	23	24	25
		Throw	1-2-3	1-2-4	2-2-5	2-3-5	2-3-6	2-3-6	2-3-6	2-3-7	2-3-7
Inlet Static Pressure 0.2	Airflow Rate, CFM	75	110	2-3-6	185	220	260	295	330	370	
	Velocity Pressure, in. w.c.	0.001	0.001	0.002	0.003	0.005	0.007	0.009	0.011	0.014	
	Total Pressure, in. w.c.	0.201	0.201	0.202	0.203	0.205	0.207	0.209	0.211	0.214	
	NC	29	29	30	31	31	32	32	32	33	
	Throw	2-2-5	2-3-6	2-3-7	2-4-7	3-4-8	3-4-9	3-5-9	3-5-10	4-5-11	
Inlet Static Pressure 0.3	Airflow Rate, CFM	95	145	190	235	280	330	375	420	465	
	Velocity Pressure, in. w.c.	0.001	0.002	0.004	0.006	0.008	0.011	0.014	0.018	0.022	
	Total Pressure, in. w.c.	0.301	0.302	0.304	0.306	0.308	0.311	0.314	0.318	0.322	
	NC	35	36	36	37	37	37	38	38	38	
	Throw	2-3-6	3-4-8	3-4-9	3-5-10	3-5-10	4-6-11	4-6-12	4-6-13	4-7-13	
Inlet Static Pressure 0.4	Airflow Rate, CFM	115	170	225	280	335	390	440	495	550	
	Velocity Pressure, in. w.c.	0.001	0.003	0.005	0.008	0.011	0.015	0.020	0.025	0.031	
	Total Pressure, in. w.c.	0.401	0.403	0.405	0.408	0.411	0.415	0.420	0.425	0.431	
	NC	38	39	40	41	41	42	42	43	43	
	Throw	2-4-7	3-4-8	3-5-10	4-6-11	4-6-12	4-7-13	5-7-13	5-7-14	5-8-15	
Inlet Static Pressure 0.5	Airflow Rate, CFM	125	190	255	315	380	440	505	565	630	
	Velocity Pressure, in. w.c.	0.002	0.004	0.007	0.010	0.015	0.020	0.026	0.032	0.040	
	Total Pressure, in. w.c.	0.502	0.504	0.507	0.510	0.515	0.520	0.526	0.532	0.540	
	NC	41	42	42	43	43	43	44	44	44	
	Throw	3-4-7	3-5-9	4-6-10	4-6-11	5-7-12	5-8-13	5-8-14	6-9-15	6-9-16	

Damper Percent Open		20	30	40	50	60	70	80	90	100	
14"	Inlet Static Pressure 0.1	Airflow Rate, CFM	50	75	105	130	160	190	220	250	280
		Velocity Pressure, in. w.c.	0.000	0.000	0.001	0.001	0.001	0.002	0.003	0.003	0.004
		Total Pressure, in. w.c.	0.100	0.100	0.101	0.101	0.101	0.102	0.103	0.103	0.104
		NC	21	22	23	24	25	25	26	27	27
		Throw	1-1-3	1-2-4	1-2-4	2-2-5	2-3-5	2-3-6	2-3-7	2-3-7	2-4-7
Inlet Static Pressure 0.2	Airflow Rate, CFM	75	115	155	195	235	275	315	355	400	
	Velocity Pressure, in. w.c.	0.000	0.001	0.001	0.002	0.003	0.004	0.005	0.007	0.009	
	Total Pressure, in. w.c.	0.200	0.201	0.201	0.202	0.203	0.204	0.205	0.207	0.209	
	NC	29	30	31	31	32	33	33	34	34	
	Throw	1-2-4	2-3-6	2-3-6	2-4-7	3-4-7	3-4-9	3-5-9	3-5-10	4-5-11	
Inlet Static Pressure 0.3	Airflow Rate, CFM	90	140	190	240	290	345	395	445	500	
	Velocity Pressure, in. w.c.	0.000	0.001	0.002	0.003	0.005	0.006	0.009	0.011	0.014	
	Total Pressure, in. w.c.	0.300	0.301	0.302	0.303	0.305	0.306	0.309	0.311	0.314	
	NC	36	37	37	38	38	38	39	39	39	
	Throw	2-3-5	2-3-7	3-4-8	3-4-9	3-5-10	4-5-11	4-6-12	4-6-12	4-7-13	
Inlet Static Pressure 0.4	Airflow Rate, CFM	105	165	225	285	345	405	465	530	590	
	Velocity Pressure, in. w.c.	0.001	0.001	0.003	0.004	0.006	0.009	0.012	0.015	0.019	
	Total Pressure, in. w.c.	0.401	0.401	0.403	0.404	0.406	0.409	0.412	0.415	0.419	
	NC	38	39	40	40	41	42	42	43	43	
	Throw	2-3-6	3-4-8	3-5-9	4-5-11	4-6-12	4-6-13	5-7-14	5-7-15	5-8-15	
Inlet Static Pressure 0.5	Airflow Rate, CFM	125	190	255	325	390	460	530	600	670	
	Velocity Pressure, in. w.c.	0.001	0.002	0.004	0.006	0.008	0.012	0.015	0.020	0.024	
	Total Pressure, in. w.c.	0.501	0.502	0.504	0.506	0.508	0.512	0.515	0.520	0.524	
	NC	42	42	43	44	44	45	45	46	46	
	Throw	2-4-7	3-5-9	4-5-10	4-6-11	4-7-13	5-7-14	5-8-15	6-8-16	6-9-16	

METALAIRE Digital Control Diffuser



MDC

## Model MDC - Application Guide

### How the MDC Controls temperature to maximize room comfort

The MDC measure both the supply and room air temperature. The DDC controller reacts to meet the requested room set point by either increasing or decreasing the volume of air through the diffuser. The MDC can be set for both maximum and minimum flow.

### How the damper is controlled

- 1) In COOL mode, the damper is positioned using proportional/integral stepped control. If the Room Temp does not reach cool set point (CSP) within (1) minute, the damper position is bumped to the next proportional band and control of integral timer is reset. Both minimum and maximum flow can be set.
- 2) In HEAT mode, the damper is positioned using staged proportional/integral control. Both minimum and maximum flow can be set.
- 3) Anytime a minimum or maximum set point is requested, the actuator is set to the appropriate maximum or minimum position.

### Slave actuator synchronization:

The MDC has a built-in function that allows for the synchronization between a master and slave unit. When a no-flow condition is detected, the master and slave will continue control for 5 minutes of no-flow. If a no-flow condition is detected for more than 5 minutes, then the actuator for both the master and slave are de-energize allowing for both units to go full open and resetting the start point between the master and slave. To allow the system to synchronize requires the system to shut down for a minimum of 15 minutes each day. It is recommended that this occur during un-occupied periods.

### Changing the set points:

The MDC will maintain a minimum of 2°F between the Cooling and Heating set points. If the COOL set point is lowered, if the difference is less than 2°F, the heating setpoint will be lowered automatically until the 2°F separation is reached. Raising the COOL set point never affects the HEAT set point.

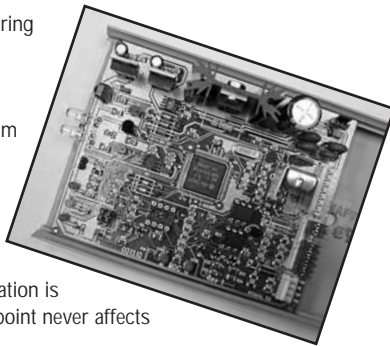

If the heating set point is raised, if the difference between the HEAT and COOL is less than 2°F, the cooling set point will automatically be raised until the 2°F separation is reached. Lowering the HEAT set point never affects the COOL set point.

### Units of Measure

The MDC can be setup to show either degrees °C or °F

### Details on Set Points

All set points (Analog Values - AVS) and Binary Value (BVS) °F or °C are stored in EEPROM. The set points are limited to the following ranges:

Description	Default Set Point Values	Range
Cooling Set Point	CSP = 76°F	70°F (21.0°C) – 80°F (26.5°C)
Heating Set Point	HSP = 70°F	68°F (20.0°C) – 78°F (25.5°C)

### Auxiliary heat rules

Built into every MDC is the ability to operate auxiliary heat such as baseboard or heating panels using a 24-volt on/off contactor built into the controller. Rules which apply to remote heaters

- 1) The Auxiliary Heat output is either ON or OFF
- 2) The Auxiliary Heat contactor ignores the HEAT/COOL mode and is continuously energized if the Room Present Set PointTemp <= (PSP-2), the ASH output is continuously energized.
- 3) If Room Temp >= (PSP-1), ASH output is de-energized.
- 4) If Room Temp is between (PSP-2) and (PSP-1), keep last state (3° dead band).



### Duct heater rules

The MDC can control electric duct heat installed up stream from the diffuser.

- 1) The duct heater is only activated in cool mode only. It is activated at Room Temp <= (CSP-2), and de-activated at Room Temp = CSP.
- 2) Since the duct heater raises the supply temp the Cool to Heat mode can only be changed while the duct heater is OFF, or if the supply air temp exceeds 110 °F while it is ON which indicates warm air being supplied to the heater.

### HEAT/COOL mode rules:

- 1) No time delays between modes.
- 2) If Supply Temp > Room Temp, HEAT mode
- 3) If Supply Temp < Room Temp, COOL mode

### Setting Minimum and Maximum Flows

Set the cool and heat minimum and the cool and heat maximum using a flow hood for accurate measurement. The following are suggested steps in the balance procedure.

- 1) Set the MDC damper with the handheld to one of the manual modes, such as Cool Maximum. The damper position in percent open may be monitored with the handheld while the damper is in manual mode.
- 2) After no more than 5 minutes, measure the airflow in CFM with a calibrated flow hood.
- 3) Adjust the Cool Maximum set point in percent, up to increase airflow or down to decrease airflow in 1% increments toward the desired airflow in CFM measured with the flow hood. Then wait for damper to move into position while monitoring it with the handheld.
- 4) Measure and adjust airflow again with the flow hood until within 5 – 10% of desired setting in CFM.
- 5) Repeat this for all 4 cool and heat minimum and maximum set points.



## Model MDC - Application Guide

### Operation with a wall mounted Stat

The MDC has the built feature allowing the use of the METALAIRE T-Stat. Once installed and the MDC powered up, the controller will run a continuous test to determine if a wall mounted METALAIRE T-Stat is installed. (The system runs a continuous test in the event a temporary T-Stat was used and removed). If the METALAIRE T-Stat is found, the MDC will use the room temperature and set points from the T-Stat only. If the T-Stat is not located, then the MDC will use the on-board sensor to measure local room temp and set points for operation.

When adjusting the temperature offset on the METALAIRE T-Stat, the cool and heat set points in on the MDC are NOT adjusted. The temperature set points are maintained at the METALAIRE T-Stat. An offset is added or subtracted to whichever cool or heat is in use at that time. These set points when set are limited to within the range of 68°F to 80°F.

The Occupied and F or C parameters have 3 sources of data. They are the METALAIRE T-Stat, or the MDC handheld and BACnet. BACnet temperature parameters are always in Fahrenheit. The Cool Set point and Heat Set point have 2 sources of data, which are the MDC handheld and BACnet. The 2 sources of data for Room Temp are the METALAIRE T-Stat or the MDC thermistor on the PCB. This data is updated on a first come, first serve basis with only one BACnet object type for each. The last to change data is the present value.

The METALAIRE T-Stat and MDC will share the following BACnet objects.

Parameter	Logistat Basic/Plus/Pro	MDC260	BACnet Object
Room Temp.	Analog Input #16 (read only)	Room Temp (AN_2 read only)	ZT_AIS
Cool Set point	+/- (0 - 3)°F Temp Offset	Analog Value #1 (writable)	MDC_AVS
Heat Set point	+/- (0 - 3)°F Temp Offset	Analog Value #4 (writable)	MDC_AVS
Occupied	Device Variable (read only)	Binary Value #16 (read only)	BVS
°F or °C	AI #16 (Eikon metric global)	Binary Value #1 (writable)	BVS

### METALAIRE HHC Hand Held Controller

The HHC is an easy to use tool to communicate directly to the MDC diffuser. The HHC is an infrared device with 2-way communication. The HHC has two modes of operation, user mode or installer mode. The user mode allows for room occupants to adjust set points, read supply air temperatures and see room air temperatures.

The installer mode converts the HHC into a setup tool and maintenance tool. The Hand Held Controller can be used to set temperatures, addresses, minimums and maximums flows. One HHC is all that is needed to set all the MDC on a project.

### How to use the HHC Hand Held Controller

The HHC works by sending requests for information to the MDC. The results of each request is displayed on the 2 line by 16 character LCD located on the HHC. The first or top line is the description of the data or label.

The second or bottom line is the present data to be read or changed. An equal sign in the extreme left of the second line of the LCD denotes the process of editing data. The acknowledgement of data entry or cancellation from the HHC to the MDC is displayed on the LCD second line with "Accepted", "Cancelled", or "Invalid". The acknowledgement does not change until a command key is pressed. In this way command keys can be pressed without any changes to data to verify the present data. The data to be read or edited is as follows:

The MDC has the power to call up pre-programmed commands as well as the ability to adjust a number of set points maximizing the flexibility of the diffuser. Using either the HHC hand held controller or by plugging into the communications port on the MDC, the following Set Points can be adjusted:

### Set Points

- BACnet Address
- Cooling set point
- Cool min damper position
- Cool max damper position
- Heating set point
- Heat min damper position
- Heat max damper position
- Temp Units F or C (Local)
- Room occupied/unoccupied

### Commands

The MDC has a number of pre-programmed Commands. These commands can be executed either by use of the HHC Hand Held Controller or by plugging into the communication port on the MDC.

### The available commands include:

- Move damper to minimum cool position
- Move damper to maximum cool position
- Move damper to minimum heat position
- Move damper to maximum heat position
- Read room temperature
- Read source temperature
- Read damper position
- Read air flow

### Data Manipulation Keys:

These data manipulation keys make changing set points and passwords easier. The up and down arrow keys increase or decrease the data by a pre-set amount regardless of cursor position. The cursor on the HHC is not moved by the UP/DOWN arrow keys.

### Number Keys (0-9)

Data is entered with the number keys from left to right starting with the most significant digit. The number keys may work in combination with the up and down arrow keys.

### Command Keys:

1. **Accept (Enter) Keys:** When pressed after data has been changed and is valid, the modified data will be stored in eeprom as the present value.
2. **Cancel Key :** Aborts present edit session, but does not change modes. Displays original data in eeprom.
3. **Display Keys :** These display keys are only pressed once to display the result. The room temperature, supply temperature, damper position and flow are updated once every 4 seconds.



**Model MDC - Application Guide**

- 4. **Room or Supply Temperature** : The resolution for Supply and Room Temperature is 1 °F and for Celsius the resolution is 0.5 °C.
- 5. **Damper Position** : Damper Position is shown as percent open in 1% increments from open to close.
- 6. **Airflow** : is shown as percent flow in 20% increments or less.

**Set Point Keys**

Set Point keys require several screens and data entry.

**Cool Set Point Key**

The Cool Set Point may be set in user mode only. The range is 70°F - 80°F (21°C - 26.5°C). If an entry is out of range, invalid entry will be displayed. Rolls over to 70 when 80 is incremented and back to 70 if decremented. The default cool setpoint (CSP) is 76 °F. Key press order: CoolSetPnt, UP/DN, Accept/Cancel

**Heat Set Point Key**

May be set in user mode only. The range is 68°F - 78°F (20°C - 25.5°C). Rolls over to 68 when 78 is incremented and back to 68 if decremented. The default heat setpoint (HSP) is 70 °F.

Key press order: HeatSetPnt, UP/DN, Accept/Cancel

**Mode Key**

The mode key sets key functions for User and Install mode. Install mode will exit when the mode key is pressed again or after 15 minutes. The range for the password is 0 to 9999. When 2-New Password is selected, the old password must be entered first in order to set the new one. When in edit mode, there is nothing displayed on the data line except an '=' at the beginning of the line. The default password is 2345.

Key press order: Mode, 1/2, UP/DN, Accept/Cancel

The MDC diffusers can communicate through either the HHC Hand Held Controller or through the network communication port.



**The following Set Points and Commands are accessed in the Install Mode Only**

**COOLMIN KEY**

Sets the cool minimum damper position. A percent open is entered within the range of 0% to 30% in 1% increments. When 30% is reached, the number rolls over to 0% and back to 30% if decremented. The default cool min (CMIN) is 5% (t\_unit = 73°C).

Key press order: CoolMin, UP/DN, Accept/Cancel

**COOLMAX KEY**

Sets the cool maximum damper position. A percent open is entered within the range of 60% to 100% in 1% increments. When 100% is reached, the number rolls over to 60% and back to 100% if decremented. The default cool max (CMAX) is 100%(t\_unit = 52°C).

Key press order: CoolMax, UP/DN, Accept/Cancel

**HEATMIN KEY**

Sets the heat minimum damper position. A percent open is entered within the range of 0% to 30% in 1% increments. When 30% is reached, the number rolls over to 0% and back to 30% if decremented. The default heat

min (HMIN) is 5% (t\_unit = 73°C).

Key press order: HeatMin, UP/DN, Accept/Cancel

**HEATMAX KEY**

Sets the heat maximum damper position. A percent flow is entered within the range of 60% to 100% in 1% increments. When 100% is reached, the number rolls over to 60% and back to 100% if decremented. The default heat max (HMAX) is 100%( t\_unit = 52°C).

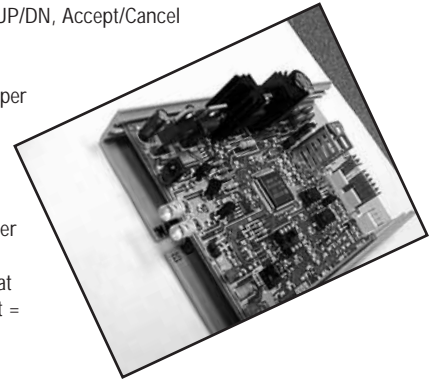

**Command Keys:**

- 1. **Accept (Enter) Keys:** When pressed after data has been changed and is valid, the modified data will be stored in eeprom as the present value.
- 2. **Cancel Key:** Aborts present edit session, but does not change modes. Displays original data in eeprom.
- 3. **Display Keys:** These display keys are only pressed once to display the result. The room temperature, supply temperature, damper position and flow are updated once every 4 seconds.
- 4. **Room or Supply Temperature:** The resolution for Supply and Room Temperature is 1 °F and for Celsius the resolution is 0.5 °C.
- 5. **Damper Position:** Damper Position is shown as percent open in 1% increments from open to close.
- 6. **Airflow:** is shown as percent flow in 20% increments or less.

**Set Point Keys**

Set Point keys require several screens and data entry.

**Cool Set Point Key**

The Cool Set Point may be set in user mode only. The range is 70°F - 80°F (21°C - 26.5°C). If an entry is out of range, invalid entry will be displayed. Rolls over to 70 when 80 is incremented and back to 70 if decremented. The default cool setpoint (CSP) is 76 °F.

Key press order: CoolSetPnt, UP/DN, Accept/Cancel

**Heat Set Point Key**

Rolls over to 68 when 78 is incremented and back to 68 if decremented. The default heat setpoint (HSP) is 70 °F.

Key press order: HeatSetPnt, UP/DN, Accept/Cancel

**Mode Key**

The mode key sets key functions for User and Install mode. Install mode will exit when the mode key is pressed again or after 15 minutes. The range for the password is 0 to 9999. When 2-New Password is selected, the old password must be entered first in order to set the new one. When in edit mode, there is nothing displayed on the data line except an '=' at the beginning of the line. The default password is 2345.

Key press order: Mode, 1/2, UP/DN, Accept/Cancel

The MDC diffusers can communicate through either the HHC Hand Held Controller or through the network communication port.





## Model MDC - Application Guide

**The following Set Points and Commands are accessed in the Install Mode Only**

### COOLMIN KEY

Sets the cool minimum damper position. A percent open is entered within the range of 0% to 30% in 1% increments. When 30% is reached, the number rolls over to 0% and back to 30% if decremented. The default cool min (CMIN) is 5% (t\_unit = 73°C).

Key press order: CoolMin, UP/DN, Accept/Cancel

### COOLMAX KEY

Sets the cool maximum damper position. A percent open is entered within the range of 60% to 100% in 1% increments. When 100% is reached, the number rolls over to 60% and back to 100% if decremented. The default cool max (CMAX) is 100%(t\_unit = 52°C).

Key press order: CoolMax, UP/DN, Accept/Cancel

### HEATMIN KEY

Sets the heat minimum damper position. A percent open is entered within the range of 0% to 30% in 1% increments. When 30% is reached, the number rolls over to 0% and back to 30% if decremented. The default heat min (HMIN) is 5% (t\_unit = 73°C).

Key press order: HeatMin, UP/DN, Accept/Cancel

### HEATMAX KEY

Sets the heat maximum damper position. A percent flow is entered within the range of 60% to 100% in 1% increments. When 100% is reached, the number rolls over to 60% and back to 100% if decremented. The default heat max (HMAX) is 100%( t\_unit = 52°C).

Key press order: HeatMax, UP/DN, Accept/Cancel

### ADDRESS KEY

Sets the BACnet MS/TP address for the MDC260. The acceptable range is 1 - 254. When 255 is reached, the number rolls over to 0 and back to 255 if decremented. The default address is 0 or 255 which ever prevents participation on the network.

Key press order: Address, UP/DN, Accept/Cancel

### DAMPER MAN/AUTO KEY

Sets damper control to auto or manual. In auto, the MDC260 algorithm controls the damper. In manual, the damper is open or closed according to the accepted enumeration. The red error LED will blink slowly while in manual mode. This is a non-volatile parameter. The enumerations are auto(1), full open(2), cool max(3), heat max(4), cool min(5), heat min(6), and full close(7). Rolls over from full close(7) to auto(1) and back. The default enumeration is auto(1).

Auto(1)	MDC control
Full open(2)	T_unit = 52°C or 100% flow
Cool Max(3)	AV CMAX set point
Heat Max(4)	AV HMAX set point
Cool Min(5)	AV CMIN set point
Heat Min(6)	AV HMIN set point
Full close(7)	T_unit >= 74°C or <= 10% flow

Key press order: Dmpr M/A, UP/DN, Accept/Cancel

### HEATER\_TYPE KEY

Sets the Auxiliary Heater Type to the enumerated value of remote(0) or duct(1). The default Aux. Heater Type is remote.

Key press order: HeaterType

### DUCT\_HTR\_OT KEY

Sets the Duct Heater Over Temp power off (only applies to duct heaters). A temperature is entered within the range of 90°F to 120°F in 1° increments. When 120°F is reached, the number rolls over to 90°F and back to 120°F if decremented. The default Duct Heater Overtemp is 110°F.

Key press order: DuctHtrOT, UP/DN, Accept/Cancel

1. The IR remote handheld specification is in filename "IRH-03.doc". The hand held keys are identified on the following page. A template will be necessary for the install mode on the handheld. Keys with the same function whether in User or Install mode are listed below.

Mode	Numbers 0-9
Up Arrow	Accept
Down Arrow	Cancel

We have 14 keys available for multiple functions. The following is a list of key functions that are different for each mode.

Key #	User mode	Install mode
2		
3		
5	CoolSetPnt	
6	HeatSetPnt	
8		CoolMin
9		HeatMin
10		CoolMax
11		HeatMax
12		Address
13		Auto/Manual
16		DamperPos
17	SourceTemp	
18	RoomTemp	
19	Flow	
20	Occupied	HeaterType
21	°F/°C	DuctHtrOT

### BACnet Identification Number

ASHRAE has assigned METALAIRE the following BACnet Vendor Identification Number: 45

**Model MDC - Communication Network Protocol**

Communication Network Protocol is BACnet Master Slave/Token Passing (class 2)			
Object Type	Instance	Description	BACnet Property Type
Device	Variable	MDC device object	Tied to BACnet address
File	1	Main firmware file	
Analog Input	1	Source (Supply) Temp (AN_3 - thermistor) UNITS= ° F only	PROPTYPE_TEMP_REAL PA_RO, PA_S
Analog Input	2	Damper Position (AN_4 - LM35DM) UNITS= PERCENT RANGE=0..100	PROPTYPE_FLT_12_4 PA_RO, PA_S
Analog Input	15	Flow sensor – Delta T (AN_5 - heated thermistor) UNITS=PERCENT RANGE=0..100	PROPTYPE_FLT_12_4 PA_RO, PA_S
Analog Input	16	Zone Temp (AN_0 or AN_2 - thermistor) UNITS= ° F only	PROPTYPE_TEMP_REAL PA_RO, PA_S
Analog Input	17	Setpoint adjust offset UNITS = °F only RANGE=0..3 Determined by AI16	PROPTYPE_FLT_12_4 PA_WR, PA_S
Analog Value	1	Cool Set point UNITS= °F only RANGE=70..80	PROPTYPE_TEMP_REAL PA_WR, PA_N
Analog Value	2	Heat Set point UNITS= ° F only RANGE=68..78	PROPTYPE_TEMP_REAL PA_WR, PA_N
Analog Value	3	Cool Minimum Damper Position UNITS= PERCENT RANGE=0..30	PROPTYPE_FLT_12_4 PA_WR, PA_N
Analog Value	4	Heat Minimum Damper Position UNITS= PERCENT RANGE=0..30	PROPTYPE_FLT_12_4 PA_WR, PA_N
Analog Value	5	Cool Maximum Damper Position UNITS= PERCENT RANGE=60..100	PROPTYPE_FLT_12_4 PA_WR, PA_N
Analog Value	6	Heat Maximum Damper Position UNITS= PERCENT RANGE=60..100	PROPTYPE_FLT_12_4 PA_WR, PA_N
Analog Value	7	Duct Heater Overtemp UNITS= °F only RANGE=90..140	PROPTYPE_TEMP_REAL PA_WR, PA_N
Analog Value	16	Timed Local Override (Logistat switch) UNITS=SECONDS	PROPTYPE_U16_REAL PA_WR, PA_S
Multi-State Value	1	Damper Control Enumerated (auto(1), full open(2), cool max(3), heat max(4), cool min(5), heat min(6), full close(7) )	PROPTYPE_U8_CMND PA_WR, PA_N
Binary Value	1	Units = °F or °C Enumerated (Off = °F, On = °C) Units = °F or °C	PROPTYPE_ENUM_8 PA_WR, PA_N
Binary Value	2	Heater Type Enumerated (Off = Remote, On = Duct)	PROPTYPE_ENUM_8 PA_WR, PA_N
Binary Value	16	Occupied/Unoccupied Enumerated (Off = UnOcc., On = Occ.)	PROPTYPE_ENUM_8 PA_RO, PA_S



## Control System Diagram

### MDC Stand Alone



**Simple Installation  
Requires 24 Volt Connection**

### MDC Master/Slave Units

Master MDC unit can control up to 3 slaves units

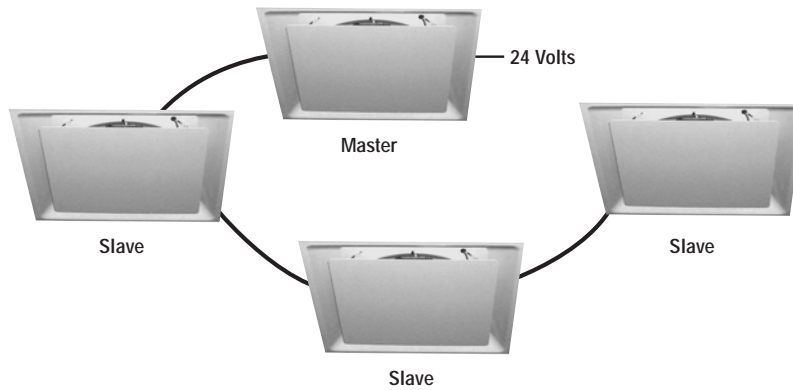

### Expands to integrate into BACnet system

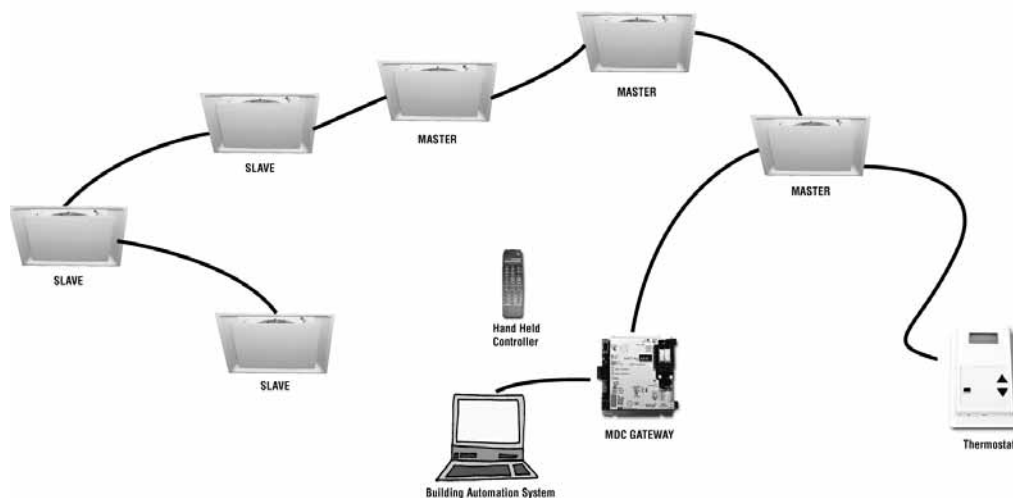

## Control System Diagram

### MDC Stand Alone

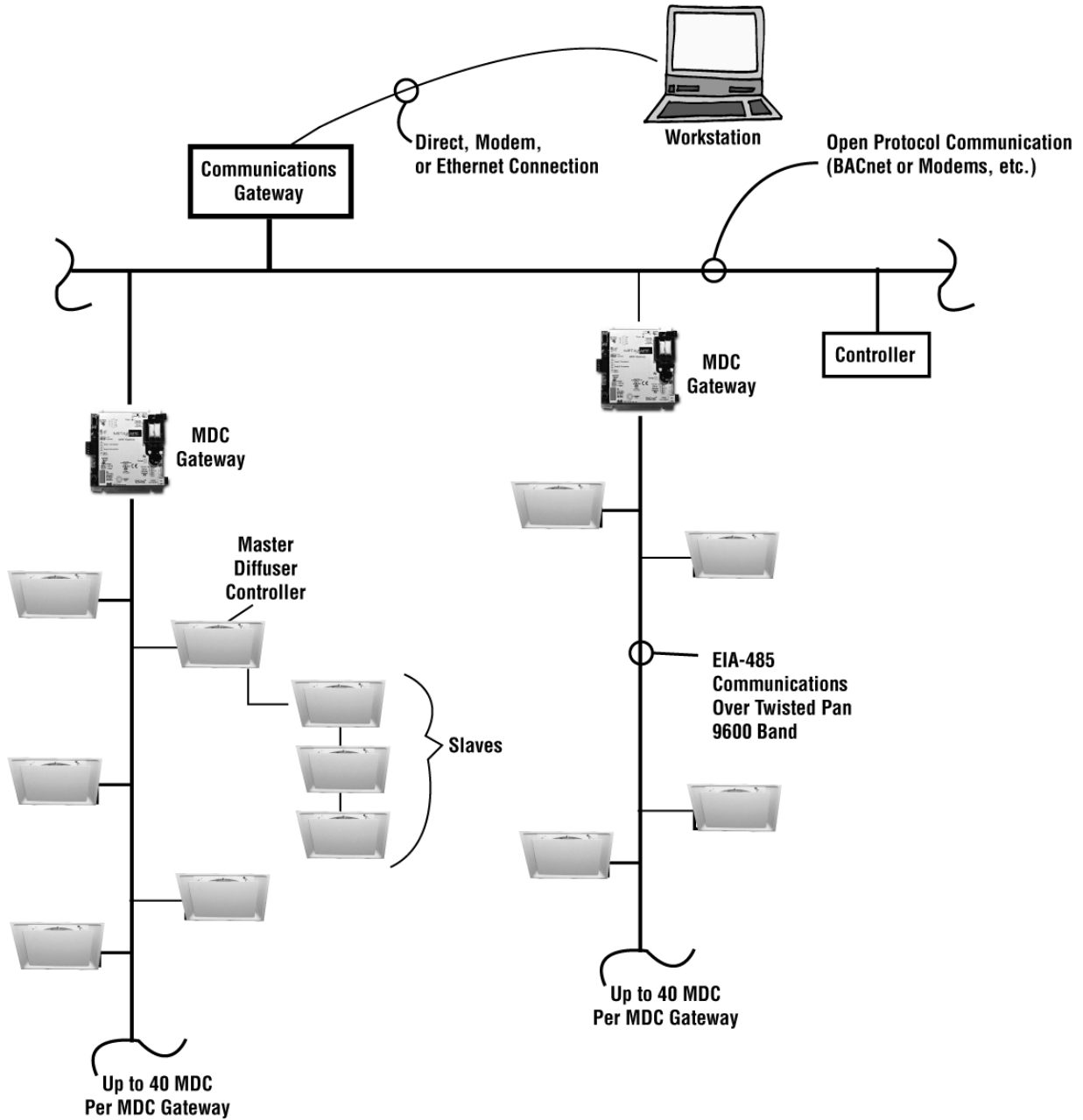

## Model MDC - Control System Diagram

### MDC Stand Alone

- MODBUS

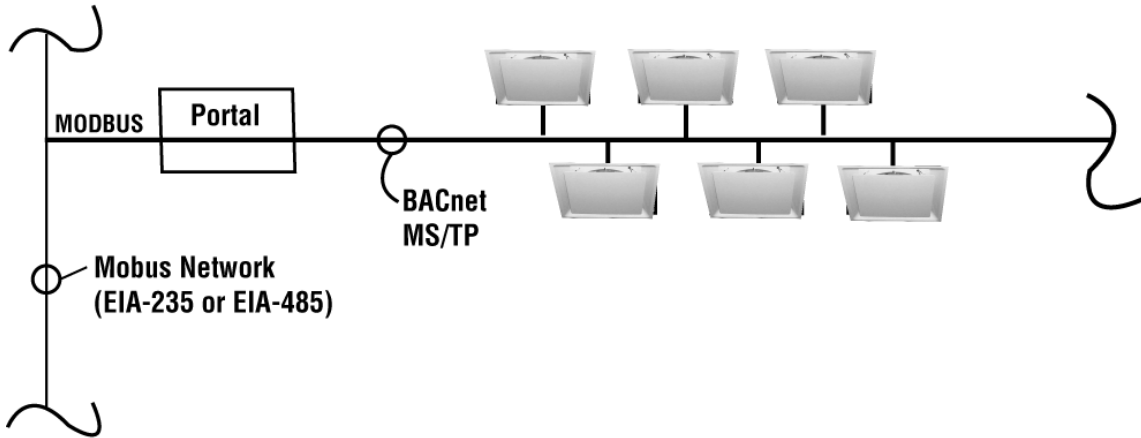

- Johnson Control's N2 Protocol

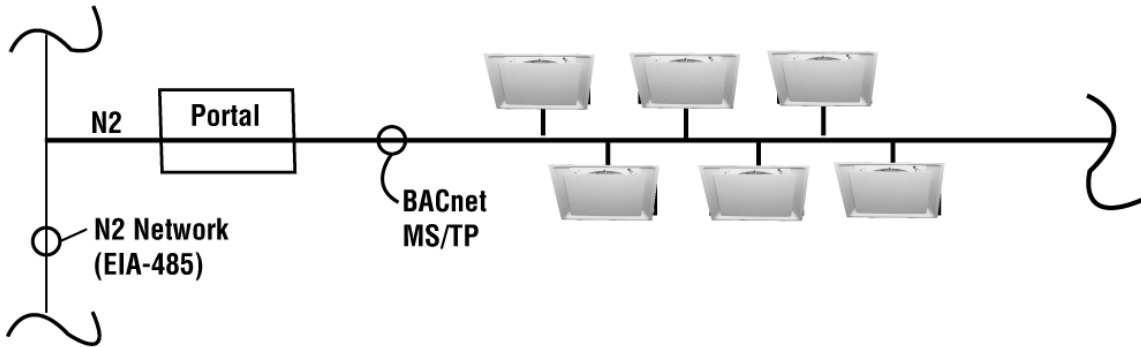

- LonWorks

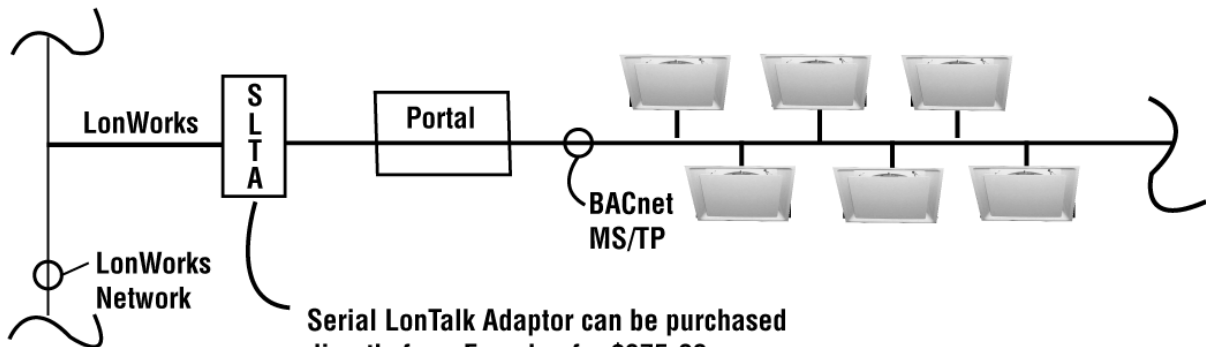

Serial LonTalk Adaptor can be purchased directly from Ecmelon for \$375.00

## Model MDC - Control System Diagram

### MDC Stand Alone

#### • MODBUS

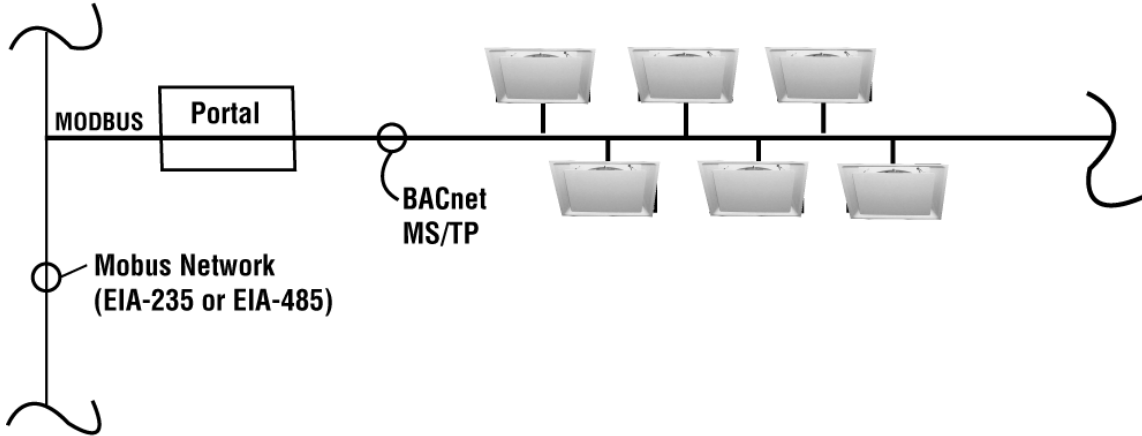

#### • Johnson Control's N2 Protocol

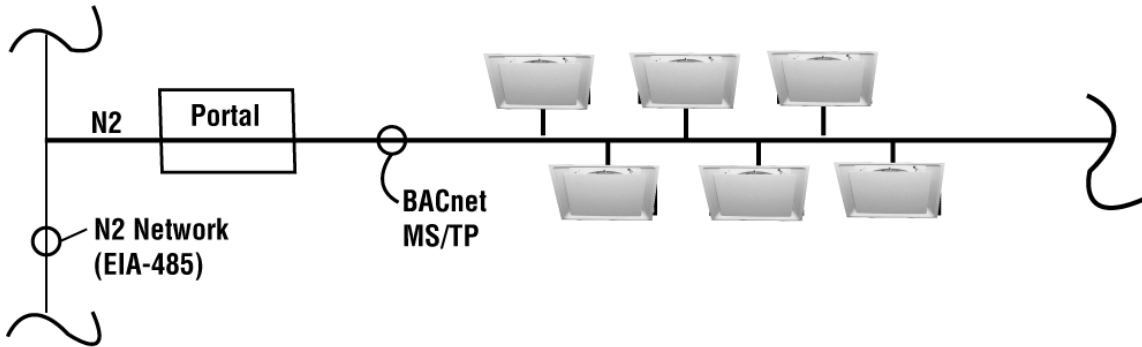

#### • LonWorks

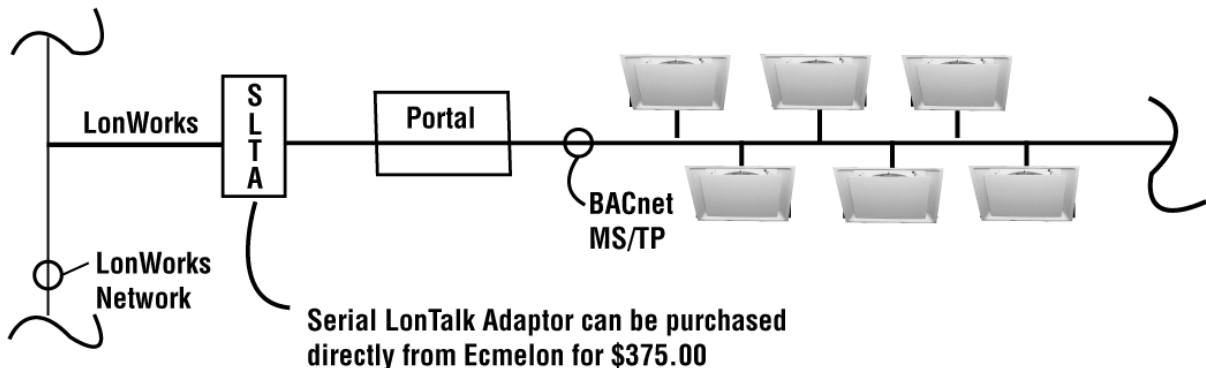

## Model MDC - Installation and Product Specifications

### USAGE of MDC

The Metal-Aire Diffuser Controller (MDC) is designed for controlling a diffuser(s) using a hot wax actuator to maintain zone temperature. The MDC may control one diffuser and up to 3 slave diffusers. The MDC module has a stand-alone control algorithm, but should be connected on a network to allow convenient firmware upgrades. A network of MDC modules may communicate by BACnet MS/TP with the MDC gateway. The user may view or change parameters using the handheld remote. The handheld remote uses bi-directional infrared (IR) communications and supports two modes: user and installer. The user mode allows changing of heating and cooling set points, occupied status. User mode also allows viewing measurements such as room temperature, source air temperature, and air flow. The installer mode is used for configuring the MDC after installation.

### SPECIFICATIONS

#### POWER

24 VAC +/-10% (1), 50-60Hz,  
 24 VA module (2)  
 8 VA/hot wax actuator (total of 4)  
 12 VA heater control output  
 68 VA total, 2.8A maximum  
 (Single Class 2 source, 100 VA or less)

(1) The +/-10% specification does not apply to the hot wax actuator, which is very sensitive to low voltage conditions.

(2) This includes additional power for an array type flow sensor. The existing module is 12 VA.

#### OUTPUTS

2 opto-isolated Triac outputs:  
 ACT rating 0.35 A (one hot wax actuator)  
 DO1 rating 1.05 A (three hot wax actuators maximum)  
 DO2 rating 0.5A  
 Note: ACT and DO1 outputs are connected together on the printed circuit board.

#### INPUT RESOLUTION

10 bit.

#### COMMUNICATION

9600 bps or 38.4 kbps, automatically detected  
 (determined by MDC gateway module).

#### ENVIRONMENTAL OPERATING RANGE

0 to 130 °F (-17.8 to 54.4 °C)

#### STATUS INDICATION

Visual (LED) indicators.

#### PROTECTION

Metal oxide Varistor (power, digital outputs, Logistat inputs).  
 Transient voltage suppressor (Logistat). Zener protection  
 (communications).

#### MEMORY

60KB Flash EPROM and 2KB of RAM, 8KB non-volatile storage for configuration data.

### MOUNTING

Mount the MDC using 4" snaptrack on the lower plate of the diffuser near the edge with the infrared (IR) components facing down. Mounting the MDC near the edge is required to use the handheld remote and view status LEDs.

### CONNECTORS

AMP MTA-100 22 AWG receptacle part number 640440-x, where x is the number of terminals

### CRIMPING TOOL :

An AMP crimping tool is also needed which consists of a handle (part # 58074-1) and a head assembly (part # 58246-1).

### THERMISTORS :

The MDC requires the following thermistors to sense air flow.

#### Source Air

Alpha Mini-Series, 62A1002-C3  
 10,000 ohms @ 25 °C, 28AWG, 2 inch leads

#### Flow Sensor

Alpha Mini-Series, 62A2251-C3  
 2252 ohms @ 25 °C, 28AWG, 2 inch leads

### FLOW SENSOR WIRING

Use a 13" long 22AWG stranded, 4 conductor cable to connect the flow and source air temperature thermistors to the MDC as shown in setup diagram (page 21).

NOTE: The source air and flow thermistors look almost identical. Make sure the 2252 ohm thermistor is connected to the FLWA and FLWB terminals.

### POWER WIRING/TRANSFORMER SIZING

The most important power consideration is providing adequate voltage to the hot wax actuators. The MDC is designed for a +/-10% voltage range, but the hot wax actuator does not work well at lower voltage. The power dissipation of the hot wax actuator and the resulting heating time varies drastically with supply voltage, as the table 1 shows.

Table 1 – Actuator Heating Time

Supply Voltage (VRMS)	Heating Time (23 - 7°C)
22.5	83 ?
27	8.3

Note: The triac output on the MDC has a typical voltage drop of 0.9 V regardless of the number of hot wax actuators used.

### TRANSFORMER SIZING RECOMMENDATION

- one MDC, 4 diffusers use 100 VA transformer.
- two MDCs, two diffusers, 100 VA transformer.

### Basic Power Guidelines

- Install 24 VAC transformer as close as possible to first MDC.
- Minimize length of power wiring (less than 50 ft total if possible)
- Use 14 AWG for power wiring.
- Avoid using slaved diffusers in areas known for low-line conditions.
- Oversize transformer to minimize voltage drop in windings.





**Model MDC - Installation and Product Specifications**

• With slaved diffusers, run a separate ground wire to the other diffusers.  
See setup diagram (page 21).

**LEDs**

The MDC module has diagnostic LEDs to assist in troubleshooting.

RUN LED (Green)	
Sequence	Meaning
2 times per second	Normal operation/Auto Mode transferring firmware
5 times per second	
Once every 2 seconds	Auto-detecting baud rate

ERROR LED (Red)	
Sequence	Meaning
Once every 2 seconds	Manual Mode
5 times per second	transferring firmware
2 times per second	Firmware error Transfer memory to the module to correct

**COMMUNICATION LEDs**

**TX** On when module transmits on network port.  
**RX** On when module receives data on network port.

**ADDRESSING**

The MDC stores the BACnet MS/TP address in non-volatile memory (EEPROM). The handheld remote must be used to set the address. To set the address, enter installer mode and use the address button using the following key sequences:

Mode Key
1
enter password up to 4 digits (for production default is 2345, for beta modules default is 1)
Accept
Address button
Enter address
Accept button

**Note:**

The password can be changed by selecting option 2 instead of option 1.

**HANDHELD REMOTE**

When using the remote, point it upward toward the MDC's infrared (IR) sensors near the edge of the diffuser. For reliable communications between the remote and MDC, the remote must be pointed used within a cone of approximately 15 - 20° from vertical below MDC's IR sensor.



# LEADING THE INDUSTRY IN PRODUCT LITERATURE

With the choice of our Pre-Flite Catalog, Quick Select Catalog, InfoSource Catalog, InfoSource CD and our web site, [www.metalaire.com](http://www.metalaire.com), you pick the format for product information that best suits your air distribution design needs.

## Pre-Flite - Product Overview Catalog

The METALAIRE Pre-Flite catalog is a condensed reference guide containing concise listings of our entire product line including grilles, registers, diffusers, and air terminal units. This catalog can be used to help select the type of device, along with available border styles. The catalog includes photos of each model along with the features and model guide, a great tool when you are trying to select a device for your project.



## Quick Select Catalog - Air Distribution Selection Made Easy

The METALAIRE Quick Select Catalog is designed to save you time selecting air distribution equipment. This catalog is a compact version of our InfoSource Catalogs and includes drawings and performance for our most popular products. The Quick Select Catalog is broken into product types with each section beginning with a model summary that includes features and benefits of our products. To obtain product information not included in the Quick Select Catalog, simply go to our web site at [www.metalaire.com](http://www.metalaire.com).



## InfoSource Catalog Suite - Complete guide to Air Distribution Selection

The METALAIRE InfoSource Catalog suite is the leading product catalog in the industry. Included in these catalogs are the complete product listings, drawings, product features and benefits, product performance data, specifications, and model specifications. These catalogs are organized to make it quick and easy to find the information you are looking for.

### InfoSource Catalog Suite

- Ceiling Diffusers Catalog
- Grilles & Registers Catalog
- Air Terminal Unit Catalog
- Formations Catalog

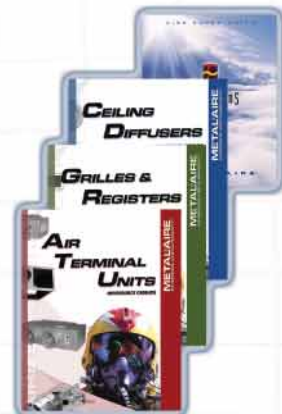

## InfoSource CD

Our InfoSource CD has set the standard in the industry for air distribution product selection. This CD contains a complete library of all our catalogs and submittals along with our air terminal unit selection program.



## Web Site: [www.metalaire.com](http://www.metalaire.com)

METALAIRE leads the industry with a web site that contains all the product literature and performance data needed to design your air distribution system. Our web site includes all our submittals, catalogs, installation manuals, as well as as other valuable information to aid you in air distribution design.



**METALAIRE**  
EXPERIENCE AIRE SUPERIORITY.

# UNDERFLOOR DIFFUSER

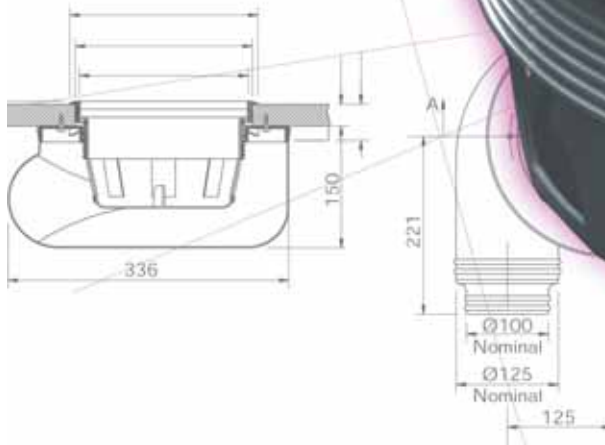
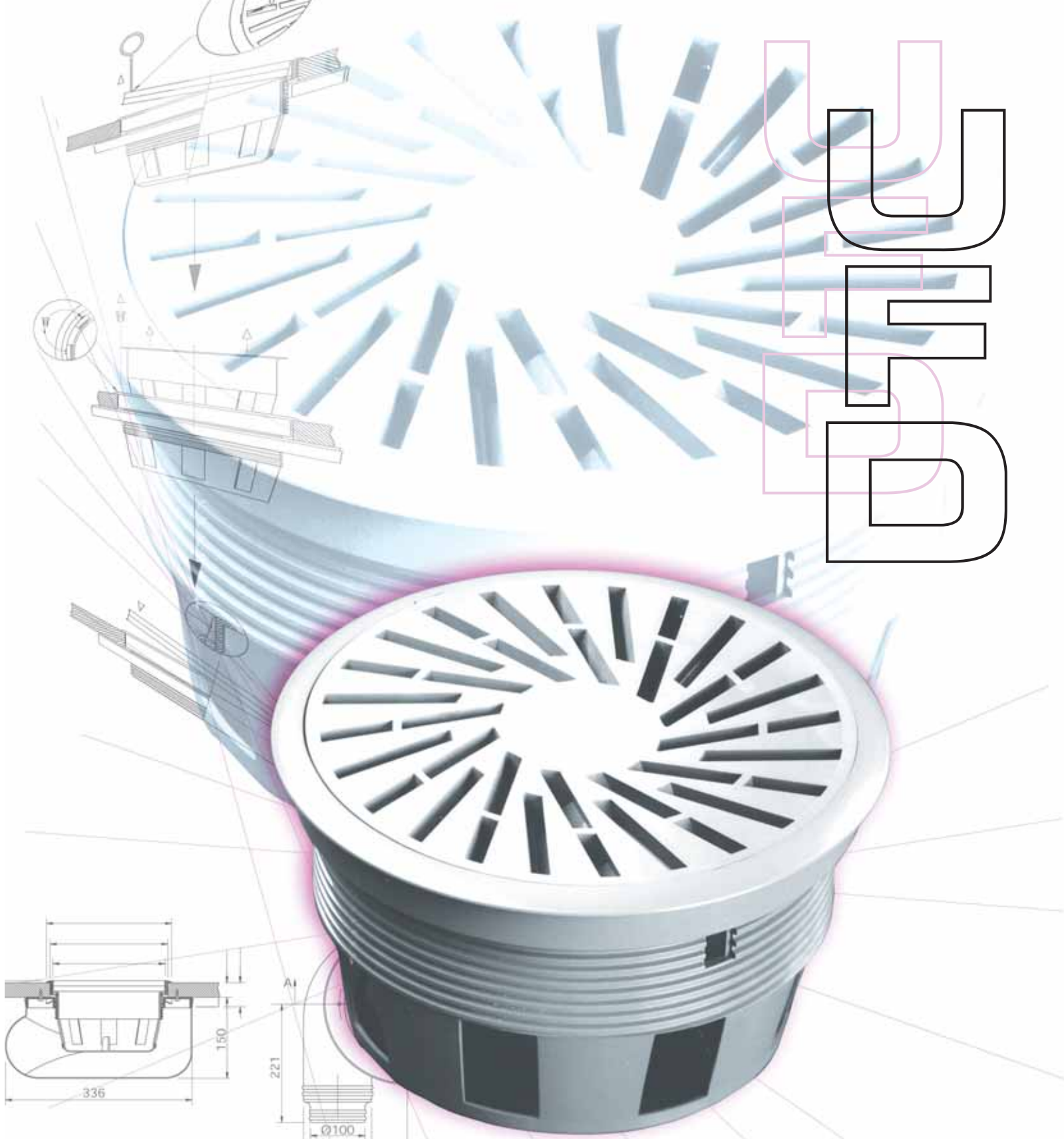

WFOP & WFOPV

## UNDERFLOOR DIFFUSER

UNDERFLOOR  
DIFFUSER

## ➔ Aircell Polymer Floor Diffuser ➔ Series WFO

### Product Details

- ★ Unique "flip-over" design
- ★ Memory locating peg
- ★ Easy fit locking collar
- ★ Concealed bracket for concrete/slab flooring
- ★ Combined damper/dirt tray with incremental damper positioning



**Model WFO Shown**

### Series WFO - Introduction

The METALAIRES Aircell WFO series floor diffuser offers the choice of horizontal or vertical air patterns with its flip over design, as well as a host of other unique & patented features. The WFOV low pressure vertical supply disc offers vertical projection with a 50% increase in air volume capacity, compared with standard WFO units.

The WFO diffusers disc has been designed to resist permanent deformation when subjected to point loads up to 500 kg and all materials used are fire retardant. The WFOV diffuser disc is suitable for point loads up to 300 kg.

Dimensions are in inches

**Aircell Polymer Floor Diffusers - Pressurized Floor Void**  
 Model WFO - Tile Installation  
 Model WFOV - Low pressure vertical air pattern

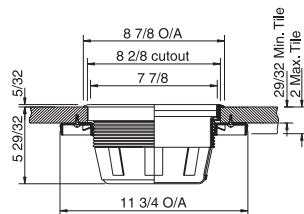

**Aircell Polymer Floor Diffusers - Pressurized Void**  
 Model WFOV - Slab Floor Installation Supplied with a steel adaptor collar which is cast into the floor slab. The diffuser can then be installed into the collar with concealed spring clips

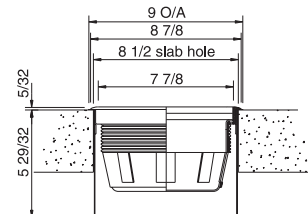

**Aircell Polymer Floor Diffusers-Ducted Insulation with Plenum Supplied**  
 Model WFOP - Plenum snap fits onto the locking collar  
 Model WFOPV - Low pressure vertical air pattern disk

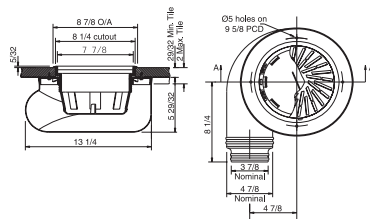

**Aircell Polymer Floor Diffusers - Step Drilled Installation**  
 Model WFOD - The diffuser disc only is supplied, suitable for installation into pre-cut holes in floor tiles

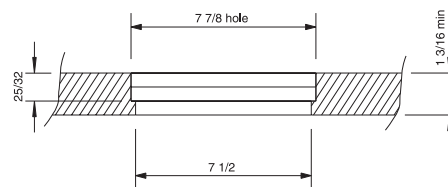

#### 1. Available Finishes

**Standard Finish:**  
 WFO diffusers are available in a state grey finish (RAL 7037 Mid Grey) as standard. Other colors can be specified subject to a minimum quantity.

#### 2. Advantages

- Ability to change between horizontal and vertical settings instantly
- Commissioning settings are retained once set using the memory locating peg
- Reduced installation time with easy fit locking collar
- Quick fit plenum





AAA  
CCC  
CCC

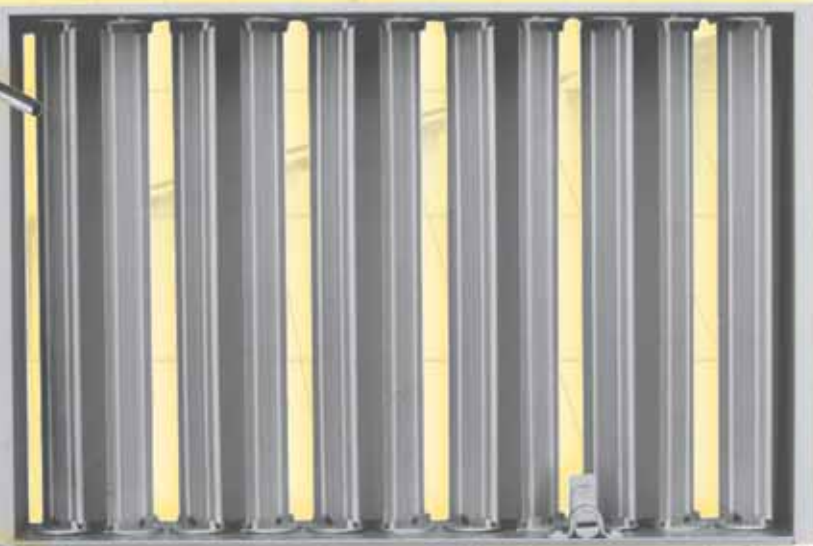
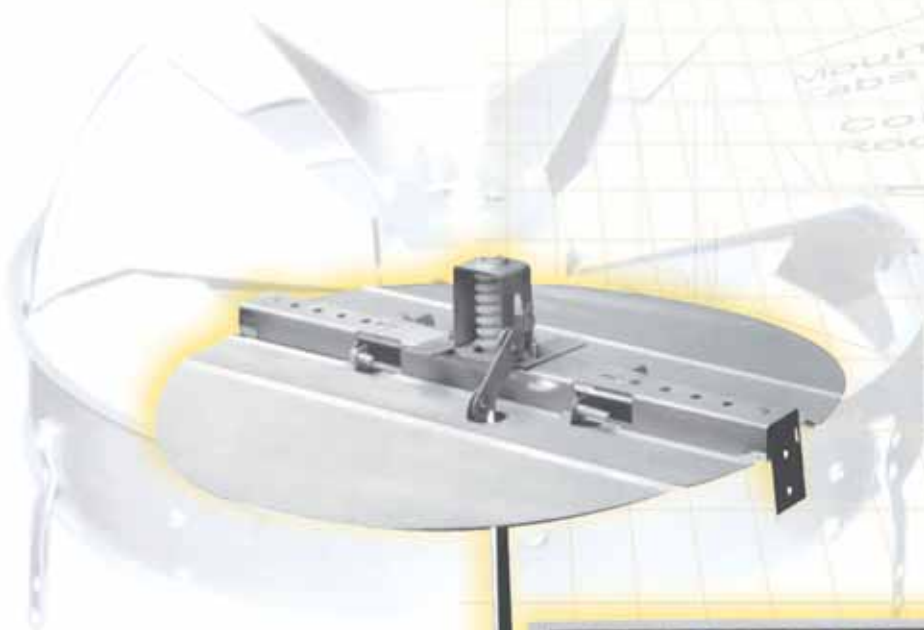

**ACCESSORIES**  
ACCESSORIES

# Ceiling Diffusers - Accessories

8/2006

## Square/Rectangular Equalizing Grid ➔ Aluminum ➔ Model L9

- ✦ Designed to provide uniform airflow in branch ducts
- ✦ Pre-tensioned blades adjust individually and may be set at an angle at the branch take-off to provide a rake-off effect

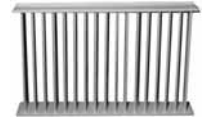

Dimensions are in inches

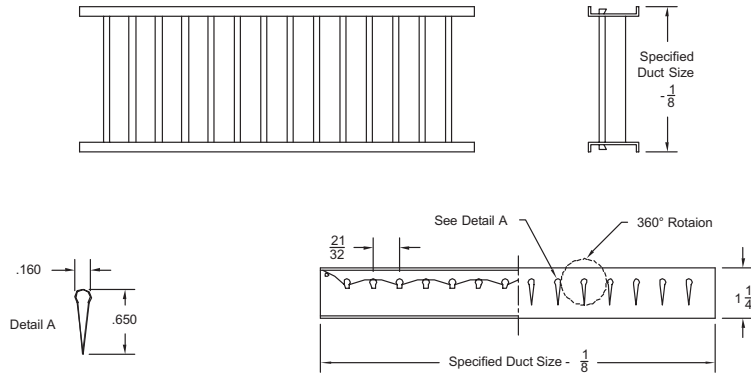

## Opposed Blade Damper for Grilles ➔ Aluminum ➔ Model OBDA ➔ Aluminum ➔ Model OBD

- ✦ Tapered blades set in a U-channel frame
- ✦ Opposed blades on 1" centers
- ✦ Screwdriver slot operator

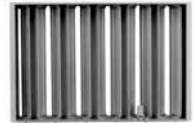

Sideview, dimensions are in inches

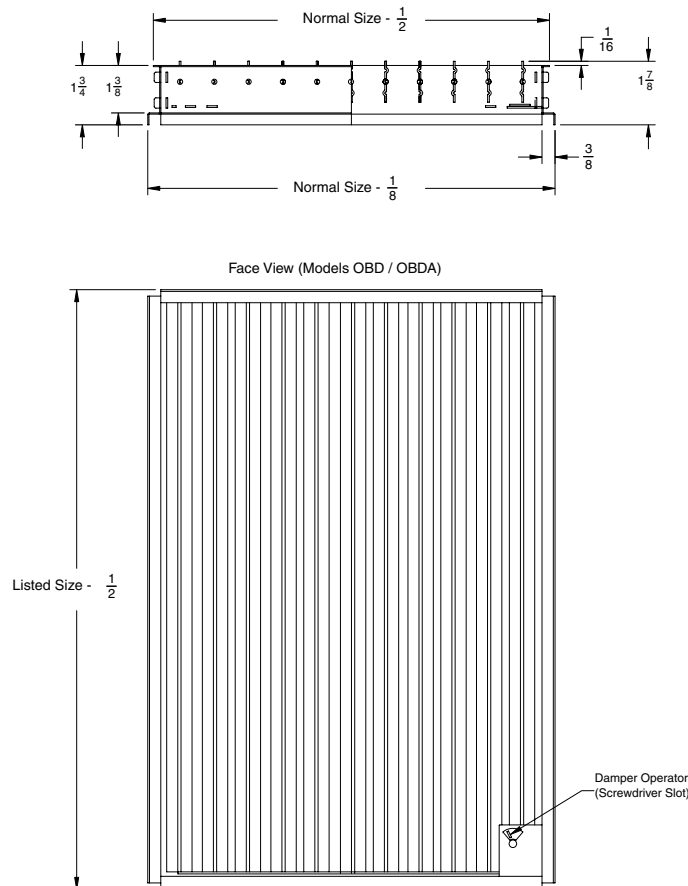

# Ceiling Diffusers - Accessories

## Optional Mitered Corners

Available for installation in ceiling, floor, sill or sidewall applications, the standard horizontal (flat) mitered corner section includes an angle of 90° and is available in 0°, 15°, and 30° deflection. The corner section contains two (2) feet of straight grille, one foot on either side of the miter line (see page 8 for detail drawing). When specifying a corner section with 15° or 30° deflection, it is imperative to specify the direction of the air throw - either toward the inside or the outside of the corner. Normally inactive, corner sections are of one piece welded construction and are not supplied with dampers equalizing grids, or other accessories.



Standard Finish: 01 White

### Special Horizontal

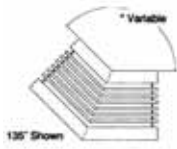

### Vertical Outside



### Vertical Inside



## Butterfly Damper ➔ Aluminum ➔ Sizes 12 and Under ➔ Model 900D\*

- For attachment to Model 900
- 2 butterfly style blades for 6" - 12" sizes
- 8 blade radial style for 14" size
- Blades adjusted through diffuser face
- Damper supplied with mounting hardware

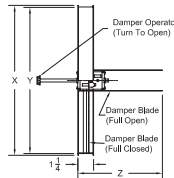
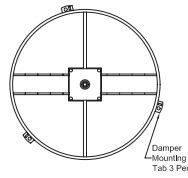

900D & 900D* Models			
Damper Sizes	X	Y	Z
6	5 15/16	5 5/8	3
8	7 15/16	7 5/8	4
10	9 15/16	9 5/8	5
12	11 15/16	11 5/8	6
14	13 15/16	13 5/8	7

## Opposed Blade Damper ➔ Aluminum ➔ Sizes 14 for Series 900 ➔ Model 900D

- For attachment to Model 900
- 2 butterfly style blades for 6" - 12" sizes
- 8 blade radial style for 14" size
- Blades adjusted through diffuser face
- Damper supplied with mounting hardware

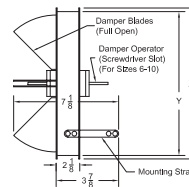
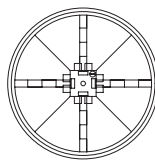

## Butterfly Damper ➔ Steel ➔ Model BDS

- Two butterfly style blades
- Blades are adjusted through diffuser face

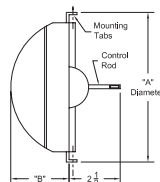
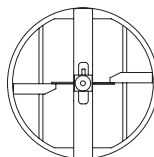

Diffuser Neck Size	BDS Dimension	
	A	B
6	5.314	2.112
8	7.314	3.112
10	9.314	4.112
12	11.314	5.112
14	13.314	6.112
15	14.314	7
16	15.314	7.112



# Ceiling Diffusers - Accessories

8/2006

## Radial Opposed Blade Damper ➔ Aluminum ➔ Model D3

- ✱ For use in round air diffusers
- ✱ Designed to provide full radial volume control resulting in lower than normal pressure losses
- ✱ Overlapping blade design insures positive shut-off when required

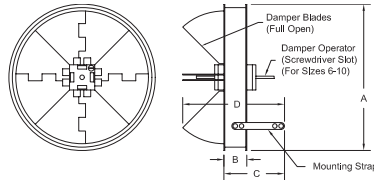

Size	A	B	C	D
6	5.7/8	1.1/4	3.1/4	4.3/4
8	7.7/8	1.1/4	3.1/4	5.1/4
10	9.7/8	1.1/4	3.1/4	6
12	11.7/8	2.1/8	3.7/8	5.5/8
14	13.7/8	2.1/8	3.7/8	7.1/8
16	15.7/8	2.1/8	3.7/8	8.7/8
18	17.7/8	2.1/8	3.7/8	9.3/8
20	19.7/8	2.1/8	3.7/8	9.7/8

## Radial Opposed Blade Damper ➔ Steel ➔ Model SD3

- ✱ For use in round air diffusers
- ✱ Designed to provide full radial volume control resulting in lower than normal pressure losses
- ✱ Overlapping blade design insures positive shut-off when required

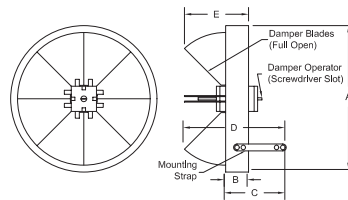

Size	A	B	C	D	E
6	5.7/8	1.7/8	3.7/8	4.1/8	2.1/8
8	7.7/8	1.7/8	3.7/8	4.7/8	2.7/8
10	9.7/8	1.7/8	3.7/8	5.5/8	3.5/8
12	11.7/8	1.7/8	3.5/8	6	4.1/4
14	13.7/8	1.7/8	3.5/8	6.3/4	5
16	15.7/8	1.7/8	3.5/8	7.3/8	5.5/8
18	17.7/8	1.7/8	3.5/8	8.1/8	6.3/8
20	19.7/8	1.7/8	3.5/8	8.7/8	7.1/8
24	23.7/8	1.7/8	3.5/8	7.3/4	6
30	29.7/8	1.7/8	6	11.5/8	7.1/2
36	35.7/8	1.7/8	6	13.1/8	9

## Radial Shutter Damper ➔ Galvanized Steel ➔ Model RSD

- ✱ Cost effective alternative to butterfly style dampers
- ✱ Design permits very precise damper control and does not interfere with diffuser air patterns

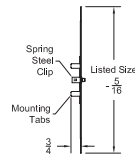
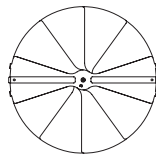

Available Sizes
6
8
10
12

# Ceiling Diffusers - Accessories

## SEC - Security Products - Accessories

### Opposed Blade Damper For 5000/7000 Series ➔ Steel ➔ Model D5/D7 ➔ Aluminum ➔ Model D5A/D7A

- ✦ Opposed blade volume damper for use with all series 5000 and 5500 diffuser models
- ✦ Damper operator is accessible at the diffuser face

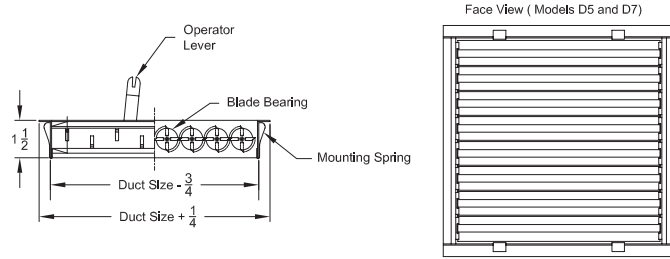

### Equalizing Grid ➔ Extruded Aluminum ➔ Model G3

- ✦ For use in round air diffusers
- ✦ Designed to provide full radial volume control resulting in lower than normal pressure losses
- ✦ Overlapping blade design insures positive shut-off when required

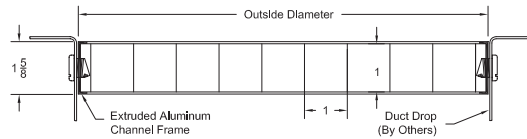

Diffuser Neck Diameter								
6	8	10	12	14	16	18	20	24
G3 Outside Diameter								
5 3/4	7 3/4	9 3/4	11 3/4	13 3/4	15 3/4	17 3/4	19 3/4	23 3/4

### Combination Grid/Damper ➔ Extruded Aluminum ➔ Model GD3

- ✦ For use with all diffusers
- ✦ Designed to provide maximum air flow equalization through use of a blade matrix system, thus ensuring lowest possible pressure losses in drop
- ✦ Dampers not available on 24" grid

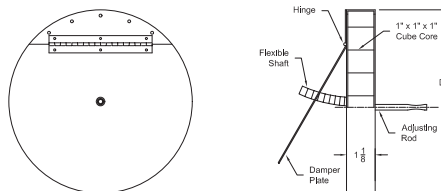

Dimension								
Size	6	6	10	12	14	16	18	20
D	5 7/8	7 7/8	9 7/8	11 7/8	13 7/8	15 7/8	17 7/8	19 7/8

# Ceiling Diffusers - Accessories

8/2006

## Square to Round Transitions ➔ Model TR

- ✦ Square to round transitions slip fit over the square neck or register to permit installation to round or flex-duct
- ✦ 2 11/16" overall depth

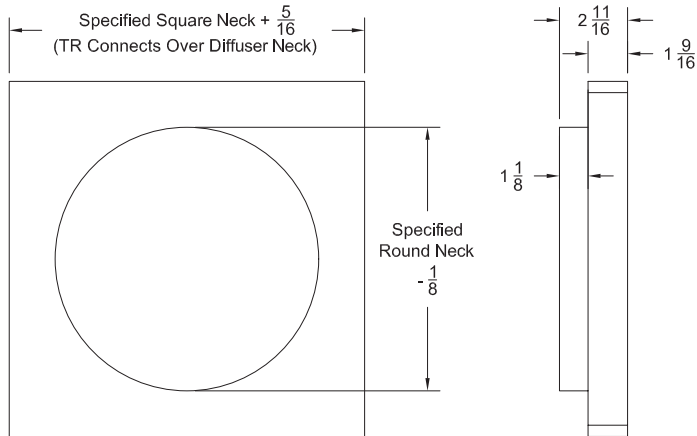

Available Sizes	
Square Neck Size	Round Neck Sizes
6 x 6	4, 5, & 6
8 x 8	5, 6, 7 & 8
9 x 9	5, 6, 7, 8 & 9
10 x 10	5, 6, 7, 8, 9 & 10
12 x 12	5, 6, 7, 8, 9, 10, 11 & 12
14 x 14	5, 6, 7, 8, 9, 10, 11, 12, & 14
15 x 15	5, 6, 7, 8, 9, 10, 11, 12, 14 & 15
16 x 16	5, 6, 7, 8, 9, 10, 11, 12, 14, 15 & 16
18 x 18	5, 6, 7, 8, 9, 10, 11, 12, 14, 15, 16 & 18
22 x 22	5, 6, 7, 8, 9, 10, 11, 12, 14, 15, 16, 18, 20 & 22

## Square to Round Deep Transitions ➔ Model TR DEEP

- ✦ Square to round transitions slip fit over the square neck or register to permit installation to round or flex-duct
- ✦ 4 7/8" overall depth

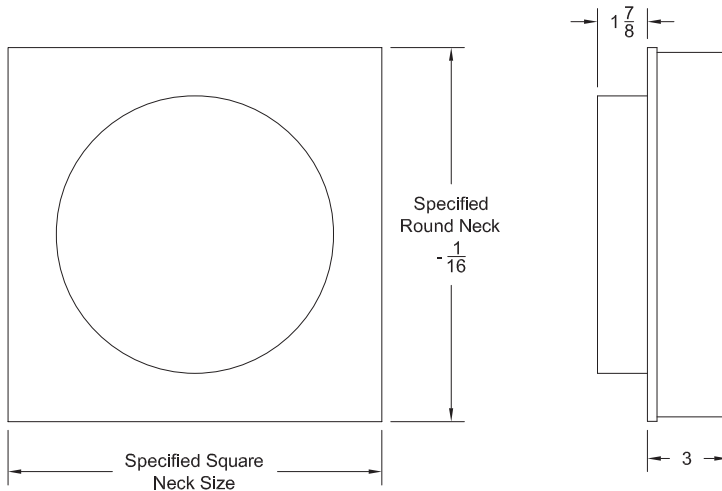

Available Sizes	
Square Neck Size	Round Duct Sizes
6 x 6	5 & 6
8 x 8	5, 6, 7 & 8
9 x 9	5, 6, 7, 8 & 9
10 x 10	5, 6, 7, 8, 9 & 10
12 x 12	5, 6, 7, 8, 9, 10, 11 & 12
14 x 14	5, 6, 7, 8, 9, 10, 11, 12 & 14
15 x 15	5, 6, 7, 8, 9, 10, 11, 12, 14 & 15
16 x 16	5, 6, 7, 8, 9, 10, 11, 12, 14, 15 & 16
18 x 18	5, 6, 7, 8, 9, 10, 11, 12, 14, 15, 16 & 18

# INDEX

---

<b>SERIES</b>	<b>SECTION</b>		
3000	.RCD-14	D5 . . . . .ACC-337	
3100	.RCD-18	D7 . . . . .ACC-337	
3200	.RCD-22	EP5000 . . . . .EPP-300	
5000	.DCD-34	EPCC5 . . . . .EPP-304	
5200	.DCD-58	EPRH . . . . .EPP-308	
5500	.DCD-46	G3 . . . . .ACC-337	
5500 DAF-CC5 . . . .	.DCD-84	GD3 . . . . .ACC-337	
5500DD . . . . .ARP-242		HPL-CL . . . . .EHD-260	
5500S . . . . .DCD-48		HPL-HA . . . . .EHD-266	
5700 . . . . .DCD-62		HPL-PR . . . . .EHD-272	
5750 . . . . .DCD-68		HRD-CL . . . . .EHD-278	
5800 . . . . .DCD-74		HRD-HA . . . . .EHD-284	
6600 . . . . .LSD-166		L-5000 . . . . .LSD-200	
6600SP . . . . .LSD-184		L9 . . . . .ACC-334	
6600SQ . . . . .ARP-248		LT . . . . .PSD-230	
7000 . . . . .PCD-104		MITERED CORNERS	ACC-335
7300 . . . . .PCD-114		MDC® . . . . .MDC-316	
7350 . . . . .PCD-116		OBD . . . . .ACC-334	
7500 . . . . .PCD-118		OBDA . . . . .ACC-334	
7550R-F . . . . .PCD-160		PERIFLOW . . . . .EHD-290	
7600 . . . . .PCD-134		PHC . . . . .PSD-224	
7900 . . . . .PCD-150		PHENOMENATOR® . .	.DCD-80
7950 . . . . .PCD-156		PHP . . . . .PSD-206	
900 . . . . .RCD-10		PRTB . . . . .PCD-112	
900D . . . . .ACC-335		R5750 . . . . .RCD-26	
9000 . . . . .DCD-94		RSD . . . . .ACC-336	
BDS . . . . .ACC-335		SD3 . . . . .ACC-336	
BP . . . . .LSD-190		TR . . . . .ACC-338	
D3 . . . . .ACC-336		TR DEEP . . . . .ACC-338	
		WFO . . . . .UFD-332	