

SERIES "W" TURBO METERS

MODEL W-160 DR Bronze Magnetic Drive Screwed Ends Size 2" (DN 50mm)



Direct Reading Registers



W-160 DR Turbo Meter

DESCRIPTION

MODEL: W-160 DR Turbo Meter is based on the turbine principle of measurement; its operating range is from 4 to 160 gallons per minute (0.9 to 36 m³/h) with registration accuracy of 100% ±1.5% of actual thruput.

CONFORMANCE TO STANDARDS: Invensys Turbo Meters comply with ANSI/AWWA Standard C701 (most recent revision). Each meter is performance tested to insure compliance.

PERFORMANCE: The meter's unique principle of measurement assures extended accuracy life. The W-160 DR has no restrictions as to sustained flow rates within its operating range. The design permits continuous operation up to its rated maximum flow capacity, without affecting long term accuracy or causing undue wear.

CONSTRUCTION: The meter consists of two basic assemblies—the maincase and the measuring chamber. Straightening vanes in the maincase minimize the swirl upstream of the meter so as to direct the flow evenly to the rotor. The measuring chamber assembly includes the rotor, adjusting vane (for calibration) and sealed Direct Reading (DR) register.

MAGNETIC DRIVE: The Right Angle Magnetic Drive eliminates conventional worm or miter gears normally required for horizontally mounted rotors or turbine measuring elements. Registration is accomplished by combining the magnetic actions of a driver magnet (embedded in the rear face of the rotor), a three-legged flux carrier and a cylindrical follower magnet attached to the gear train shaft inside the register's magnet well. Water flowing through the meter causes the rotor (with magnet) to turn; as one of the magnet poles passes one of the flux carrier legs, the magnetic force is transmitted through the flux carrier leg to the follower magnet, causing the register shaft to rotate. The only moving part in water is the rotor assembly.

ROTOR: The thermoplastic rotor with graphite bearing rotates on a chrome plated stainless steel shaft. The rotor assembly is virtually weightless in water, thus adding to bearing life.

MAINTENANCE: The measuring chamber and straightening vanes can be removed, repaired and/or replaced without disturbing the maincase in the line. A spare chamber can be utilized in the event maintenance is required. Cover plates are also available to keep the line in service while the measuring chamber is repaired and recalibrated. Factory testing, repair and measuring chamber exchange programs are available.

STRAINER: A separate strainer is recommended, but not normally required to protect the rotor. If there is debris in the pipeline, however, a separate strainer would reduce both the chance of damage and the frequency of measuring chamber removal for inspection.

SPECIFICATIONS

SERVICE	Measurement of cold water up to 80°F (27°C) with flow in one direction only.
OPERATING RANGE	Continuous Flows: 4 to 160 gpm (0.9 to 36 m ³ /h) Intermittent Flows: 200 gpm max. (45 m ³ /h)
ACCURACY	100% ± 1.5% of actual thruput
LOW FLOW	95% at 3 gpm (0.7 m ³ /h)
PRESSURE LOSS	5.6 psi at 160 gpm (.4 bar at 36 m ³ /h)
MAXIMUM OPERATING PRESSURE	150 psi (10.0 bar)
END CONNECTION	2" -11-1/2 NPT Internal Threads
REGISTER	Hermetically Sealed Direct Reading Register with Low Flow Indicator
METER REGISTRATION	100,000,000 gallons 100 gallons/sweep hand revolution 10,000,000 cubic feet 10 cubic feet/sweep hand revolution 100,000 m ³ 0.1 m ³ /sweep hand revolution
MATERIALS	Maincase—Bronze Measuring Chamber—Thermoplastic Straightening Vanes—Thermoplastic Flow Tube—Thermoplastic Rotor—Thermoplastic Radial Bearing—Graphite Trim—Stainless Steel Thrust Bearings—Tungsten Carbide Magnets—Ceramic

SERIES "W" TURBO METERS

MODEL W-160 DR Bronze Magnetic Drive Screwed Ends Size 2" (DN 50mm)

Head Loss Curve

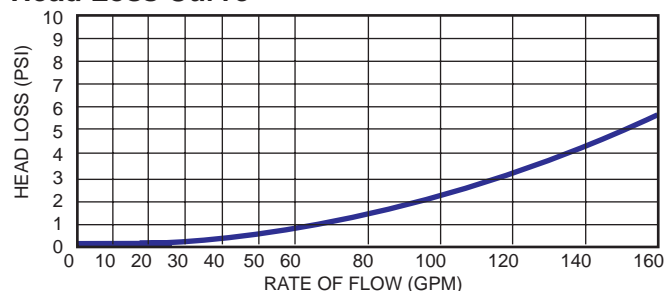

Accuracy Curve

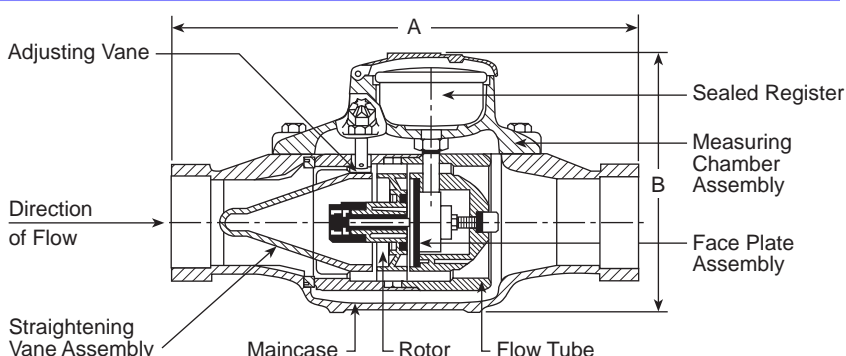
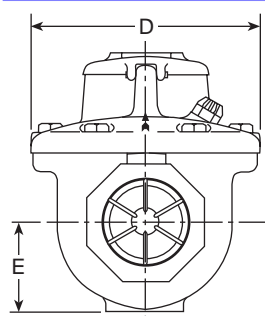
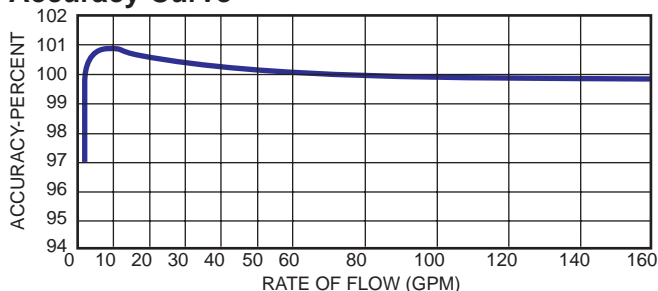

Meter and Pipe Size	Normal Operating Range GPM Minimum Maximum		Connections	Dimensions								Net Weight	Shipping Weight
				A	B	C	D	E	F	G	H		
2" DN 50mm	4 0.9m ³ /h	160 [Ⓞ] 36m ³ /h	Screwed	12"	6-3/4"	NA	6"	2-5/16"	NA	NA	NA	24 lbs.	28 lbs.
				305mm	172mm	NA	153mm	59mm	NA	NA	NA		

Ⓞ For continuous flows; 200 GPM (45m³/h) maximum for intermittent flows.

Remote Systems—For use with all sizes of Invensys Water Meters

All Invensys AMR systems work with the same absolute encoder Electronic Communications Registers (ECR), enabling the utility to mix and match or easily move from one system to another without changing registers for each.

The TouchRead® Automated Meter Reading and Billing System—is a multi-purpose encoder remote system suitable for indoor and/or outdoor use. The ECR Register uses a wired connection between the meter and an outside remote for inside set meters—or a pitlid mounted module, enabling underground meters to be read automatically without opening the meter box or vault. All wired connections and terminals of the TouchRead PitLid (TR/PL) modules and registers are fully sealed at the factory using a special process to ensure protection from water infiltration. The connection terminals of ECR/WP registers are also factory sealed.

Meters equipped for TouchRead System reading can be read with a visual reading device, stand alone AutoGun, and/or reading gun with an AutoRead Hand-Held Device. For more information on TouchRead System equipment refer to bulletins AMR-TR, AMR-401, AMR-403, AMR-312, EXSUMHH, RS-983, TR-984 and TR-995.

PhonRead® AMR—is a reliable telephone based call-in system that does not require batteries for operation. It also does not require equipment to be

installed at telephone company facilities. PhonRead Meter Interface Units (MIU) automatically call "in" to the utility office for transferring meter reading data from the meter site to a PC. PhonRead is a transparent AMR system that does not interfere with customers' telephone service. For more information refer to bulletins AMR-PR and AMR-302.

RadioRead® AMR—uses superior Direct Sequence Spread Spectrum modulation to provide reliable, safe and virtually interference free radio-based transmission of reading data from underground or inside-set meters that are equipped with Meter Transceiver Units (MXU). A choice of meter reading options is available. A radio frequency hand-held device (RF-HHD) can be used by a meter reader on foot. The RF-HHD can also be used to collect readings from TouchRead equipped meters, or for manual meter reading entries. A more powerful Vehicle Transceiver Unit (VXU) can be used in any car or truck to read meters while on the move. (A dedicated meter reading vehicle is not required.) For more information refer to bulletins AMR-RR, AMR-301 and AMR-303, and AMR-401.

MultiRead® Port Expanders—can provide the capability to connect multiple ECR equipped meters to a single PhonRead MIU or RadioRead MXU to save the utility time and money for installations such as apartment complexes and shopping centers. Refer to bulletin AMR-305, AMR-306 and AMR-308.



Invensys Metering Systems
P.O. Box 487
450 N. Gallatin Avenue
Uniontown, PA 15401
1-800-METER-IT
1-800-638-3748
FAX (Direct to Factory)
Local: (724) 439-7729
Toll Free: 1-800-888-2403
Web site: www.ims.invensys.com
select North American Water
Email: h2ointo@ims.invensys.com

AUTHORIZED INVENSYS DISTRIBUTOR