

Serenity GT Series

Two-Stage, R-410a
Packaged Horizontal & Vertical
Unit Specifications Catalog



GeoComfort[®]
Geothermal Systems

www.geocomfort.com

Table of Contents:

| | |
|--|---------|
| Product Introduction & Unit Features | 2 |
| Performance Data: AHRI - Single Compressor | 3 |
| Performance Data: AHRI - Dual Compressor | 4 |
| Unit Nomenclature: Vertical Cabinets..... | 5 |
| Unit Nomenclature: Horizontal Cabinets..... | 6 |
| Glossary, Calculations, & Water Flow Selection | 7 |
| Performance Data: GT024 - Heating..... | 8 & 9 |
| Performance Data: GT024 - Cooling..... | 10 & 11 |
| Performance Data: GT036 - Heating..... | 12 & 13 |
| Performance Data: GT036 - Cooling..... | 14 & 15 |
| Performance Data: GT048 - Heating..... | 16 & 17 |
| Performance Data: GT048 - Cooling..... | 18 & 19 |
| Performance Data: GT060 - Heating..... | 20 & 21 |
| Performance Data: GT060 - Cooling..... | 22 & 23 |
| Performance Data: GT072 - Heating..... | 24 & 25 |
| Performance Data: GT072 - Cooling..... | 26 & 27 |
| Performance Data: GT096 - Heating..... | 28 & 29 |
| Performance Data: GT096 - Cooling..... | 30 & 31 |
| Performance Data: GT120 - Heating..... | 32 & 33 |
| Performance Data: GT120 - Cooling..... | 34 & 35 |
| Performance Data: GT144 - Heating..... | 36 & 37 |
| Performance Data: GT144 - Cooling..... | 38 & 39 |
| Physical Data..... | 40 |
| Dimensional Data: Vertical Cabinets..... | 41 |
| Dimensional Data: Horizontal Cabinets..... | 42 |
| Electrical Data..... | 43 |
| Wiring Diagrams | 44 - 46 |
| Auxiliary Electric Heater Data..... | 47 |
| Blower Data | 48 |
| Operational Pressure | 49 |
| Controls | 50 - 53 |
| Engineering Specifications..... | 54 |
| Accessories & Warranty..... | 55 |
| Revision Table | 56 |

Product Introduction & Unit Features

The GT Series Product Line is highly efficient, reliable and quiet operating, year-round comfort solution for your home or business. It is available in two-stage and dual compressor models.

The GT Series Line provides exceptional operating efficiency throughout a wide range of entering water temperatures between 25°F to 110°F.

The GT Series is manufactured in the heart of America. Pride in workmanship has been deeply embedded in the culture of our company. Every department places a high value on integrity and complete customer satisfaction. "World Class Service – Hometown Values" is far more than a slogan, it's a way of life.

The GT Series comes standard with powder coated steel cabinet designed for long life and extraordinary beauty. The cabinet is bolted together, rather than using screws for unmatched integral strength. The cabinet is also insulated with 3/8" insulation (foil faced) for quiet operation and easy clean up. Another noise reduction feature is rubber mounted Scroll compressors, and rubber mounted blowers. The features work in concert to reduce vibration, which reduces noise.

All Coaxial Heat Exchangers are insulated to reduce corrosion, but also avoids condensation problems at low temperatures. Specially coated air coils add durability and longer equipment life. Additionally, the air coils are oversized providing high efficiencies at low face velocity. The Bidirectional Expansion Valve delivers optimum refrigerant flow over a wide range of conditions and provides bidirectional operation without troublesome

check valves. Highly advanced ECM Blower Motors working with Copeland's Ultratech unloading Scroll Compressor Technology delivers high efficiencies and comfort for any application.

Unit Features at a Glance

- Non-Ozone Depleting R-410A Refrigerant
- Appliance White Powder Coated Steel Construction
- Cabinet Bolted Together
- All Panels Removable for Easy Service
- Coated Air Coils For Extended Life
- Bidirectional Expansion Valve
- ECM Blower Motors
- Optional PSC Motors on Dual Compressor Units
- Corrosion-Proof, Stainless Steel, Drain Pan
- ETL Certified to UL & CSA Standards
- AHRI Certified to ISO Standards
- Copper Coaxial Water Heat Exchanger
- Flow Switch Protected
- Fault Retry To Eliminate Nuisance Service Calls
- High Efficiency Copeland UltraTech Scroll Compressor
- 10 Year Limited Warranty

Optional features

- Cupro-nickel heat exchanger
- Hot Water Generator (Desuperheater)
- Combination water-to-air / water-to-water operation
- Field installed internal electric heat
- Extended warranty

Unit Performance: AHRI Data - Single Compressor Units

Ground Loop Heat Pump

| Model | Capacity | Heating | | Cooling | |
|-------|-----------|---------|-----|---------|------|
| | | Btu/hr | COP | Btu/hr | EER |
| GT024 | Full Load | 22,200 | 3.7 | 29,000 | 16.0 |
| | Part Load | 16,500 | 4.2 | 21,500 | 20.0 |
| GT036 | Full Load | 31,400 | 3.6 | 39,400 | 18.0 |
| | Part Load | 20,900 | 4.5 | 26,300 | 24.0 |
| GT048 | Full Load | 45,600 | 3.5 | 57,200 | 17.6 |
| | Part Load | 30,300 | 4.3 | 37,900 | 23.8 |
| GT060 | Full Load | 52,200 | 3.5 | 65,400 | 17.4 |
| | Part Load | 36,500 | 4.3 | 45,700 | 23.6 |
| GT072 | Full Load | 59,700 | 3.6 | 72,000 | 14.1 |
| | Part Load | 46,600 | 3.5 | 57,500 | 19.1 |



Note:

Rated in accordance with ISO Standard 13256-1 which includes Pump Penalties.

Heating capacities based on 68.0°F DB, 59.0°F WB entering air temperature.

Cooling capacities based on 80.6°F DB, 66.2°F WB entering air temperature.

Entering water temperatures Full Load: 32°F heating / 77°F cooling.

Entering water temperatures Part Load: 41°F heating / 68°F cooling.

Ground Water Heat Pump

| Model | Capacity | Heating | | Cooling | |
|-------|-----------|---------|-----|---------|------|
| | | Btu/hr | COP | Btu/hr | EER |
| GT024 | Full Load | 25,500 | 4.1 | 30,400 | 18.4 |
| | Part Load | 18,900 | 4.8 | 22,500 | 23.0 |
| GT036 | Full Load | 36,100 | 4.1 | 41,300 | 20.7 |
| | Part Load | 24,000 | 5.2 | 27,600 | 27.6 |
| GT048 | Full Load | 52,400 | 4.0 | 60,000 | 20.2 |
| | Part Load | 34,800 | 4.9 | 39,700 | 27.4 |
| GT060 | Full Load | 60,000 | 4.0 | 68,600 | 20.0 |
| | Part Load | 41,900 | 4.9 | 47,900 | 27.1 |
| GT072 | Full Load | 68,600 | 4.1 | 75,600 | 16.2 |
| | Part Load | 53,500 | 4.0 | 60,300 | 22.1 |

Note:

Rated in accordance with ISO Standard 13256-1 which includes Pump Penalties.

Heating capacities based on 68.0°F DB, 59.0°F WB entering air temperature.

Cooling capacities based on 80.6°F DB, 66.2°F WB entering air temperature.

Entering water temperatures: 50°F heating / 59°F cooling.

Unit Performance: AHRI Data - Dual Compressor Units

Ground Loop Heat Pump

| Model | Capacity | Heating @ 32°F EWT | | Cooling @ 77°F EWT | |
|--------|----------|--------------------|-----|--------------------|------|
| | | BTU/Hr | COP | BTU/Hr | EER |
| GT096 | Full | 86,200 | 3.5 | 97,400 | 15.1 |
| | Part | 43,100 | 3.4 | 48,700 | 15.0 |
| GT120 | Full | 98,900 | 3.5 | 125,000 | 15.1 |
| | Part | 49,400 | 3.4 | 62,700 | 15.0 |
| GT144* | Full | 118,200 | 3.4 | 148,800 | 15.1 |
| | Part | 59,100 | 3.3 | 74,400 | 15.0 |



Ground Water Heat Pump

| Model | Capacity | Heating@50°F EWT | | Cooling@59°F EWT | |
|--------|----------|------------------|-----|------------------|------|
| | | BTU/Hr | COP | BTU/Hr | EER |
| GT096 | Full | 99,100 | 4.0 | 102,200 | 17.4 |
| | Part | 49,500 | 3.9 | 51,100 | 17.3 |
| GT120 | Full | 113,700 | 4.0 | 131,200 | 17.4 |
| | Part | 56,800 | 3.9 | 65,600 | 17.3 |
| GT144* | Full | 135,900 | 3.9 | 156,200 | 17.4 |
| | Part | 67,900 | 3.8 | 78,100 | 17.3 |

Note:

Rated in accordance with ISO Standard 13256-1 which includes Pump Penalties.

Heating capacities based on 68.0°F DB, 59.0°F WB entering air temperature.

Cooling capacities based on 80.6°F DB, 66.2°F WB entering air temperature.

* Performance listing only. AHRI does not certify units over 10 tons.

Unit Nomenclature: Vertical Cabinets

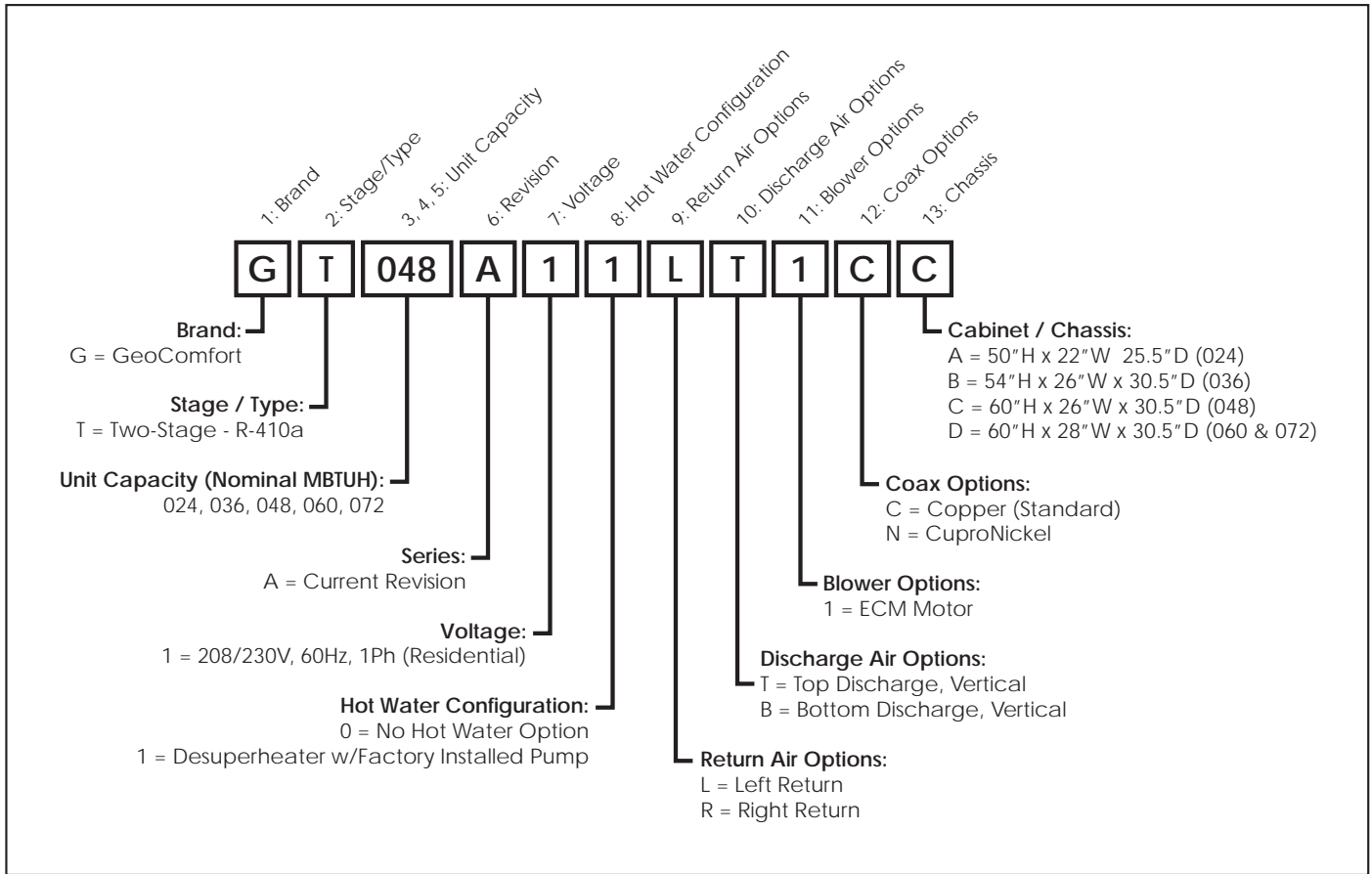

Rev.: 08 October, 2008D

Unit Nomenclature: Horizontal Cabinets

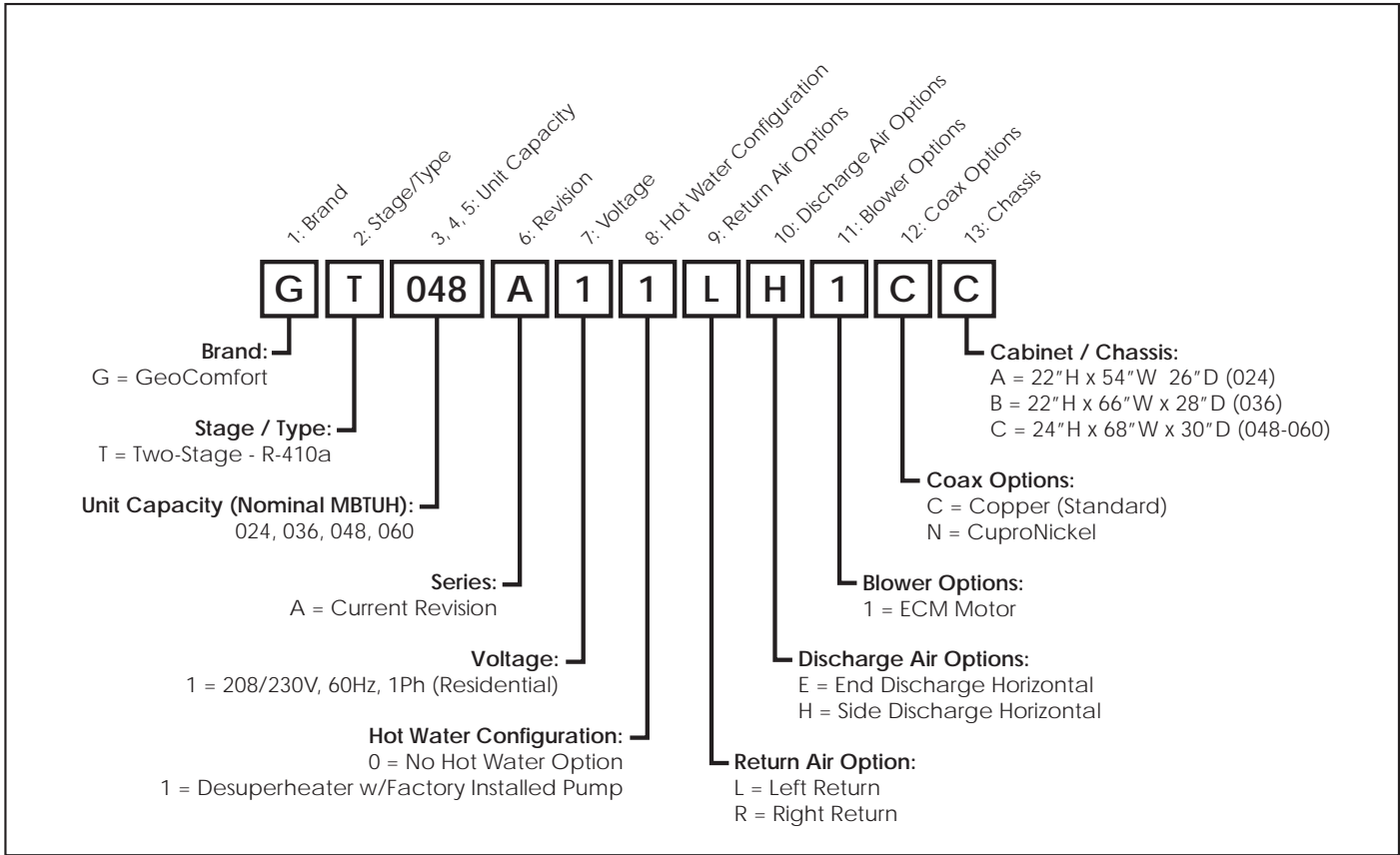

Rev.: 11 March, 2008D

Glossary, Calculations, & Water Flow Selection

Glossary of Terms

| | |
|--|--|
| CFM = Airflow, Cubic Feet/Minute | HR = Total Heat Of Rejection, Btu/hr |
| COP = Coefficient of Performance = BTU Output / BTU Input | KW = Total Power Unit Input, Kilowatts |
| DH = Desuperheater Capacity, Btu/hr | LAT = Leaving Air Temperature, Fahrenheit |
| EAT = Entering Air Temperature, Fahrenheit (Dry Bulb/Wet Bulb) | LC = Latent Cooling Capacity, Btu/hr |
| EER = Energy Efficiency Ratio = BTU output/Watts input | SC = Sensible Cooling Capacity, Btu/hr |
| EWT = Entering Source Water Temperature, Fahrenheit | LWT = Leaving Source Water Temperature, Fahrenheit |
| ELT = Entering Load Water Temperature, Fahrenheit | LLT = Leaving Load Water Temperature, Fahrenheit |
| GPM = Water Flow, Gallons Per Minute | TC = Total Cooling Capacity, Btu/hr |
| HC = Total Heating Capacity, Btu/hr | WPD = Water Pressure Drop, PSI & Feet of Water |
| HE = Total Heat Of Extraction, Btu/hr | |

Heating & Cooling Calculations

| Heating | Cooling |
|--|--|
| $LAT = EAT + \frac{HC}{CFM \times 1.08}$ | $LAT (DB) = EAT (DB) - \frac{SC}{CFM \times 1.08}$ |
| $LWT = EWT - \frac{HE}{GPM \times 500}$ | $LWT = EWT + \frac{HR}{GPM \times 500}$ |
| $LC = TC - SC$ | |

Water Flow Selection

Proper flow rate is crucial for reliable operation of geothermal heat pumps. The performance data shows three flow rates for each entering water temperature (EWT column). The general "rule of thumb" when selecting flow rates is the following:

Top flow rate: Open loop systems (1.5 to 2.0 gpm per ton)

Middle flow rate: Minimum closed loop system flow rate (2.25 to 2.50 gpm/ton)

Bottom flow rate: Nominal (optimum) closed loop system flow rate (3.0 gpm/ton)

Although the "rule of thumb" is adequate in most areas of North America, it is important to consider the application type before applying this "rule of thumb." Antifreeze is generally required for all closed loop (geothermal) applications. Extreme Southern U.S. locations are the only exception. Open loop (well water) systems cannot use antifreeze, and must have enough flow rate in order to avoid freezing conditions at the Leaving Source Water Temperature (LWT) connection.

Calculations must be made for all systems without antifreeze to determine if the top flow rate is adequate to prevent LWT at or near freezing conditions. The following steps should be taken in making this calculation:

Determine minimum EWT based upon your geographical area. Go to the performance data table for the heat pump model selected and look up the Heat of Extraction (HE) at the "rule of thumb" water flow rate (GPM) and at the design Entering Air Temperature (EAT).

Calculate the temperature difference (TD) based upon the HE and GPM of the model (step 4).

$TD = HE / (GPM \times 500)$.

Calculate the LWT (step 6).

$LWT = EWT - TD$.

If the LWT is below 35-38°F, there is potential for freezing conditions if the flow rate or water temperature is less than ideal conditions, and the flow rate must be increased.

Example 1:

EWT = 50°F.

Model GT036, high capacity. Flow rate = 5 GPM. HE = 26,700 Btu/h.

$TD = 26,700 / (5 \times 500) = 10.7^\circ\text{F}$

$LWT = 50 - 10.7 = 39.3^\circ\text{F}$

Water flow rate should be adequate under these conditions.

Example 2:

EWT = 40°F.

Model GT036, high capacity. Flow rate = 5 GPM. HE = 22,900 Btu/h.

$TD = 22,900 / (5 \times 500) = 9.2^\circ\text{F}$

$LWT = 40 - 10.7 = 30.8^\circ\text{F}$

Water flow rate must be increased.

GT024 Performance Data: 2.0 Ton, 900 CFM, High Capacity Heating

| EWT | GPM | WPD | | Heating | | | | | | Heating with Desuperheater | | | | | |
|-----|-----|-----|-----|---------|------|------|-------|------|------|----------------------------|------|-------|------|-----|------|
| | | PSI | FT | EAT | HC | HE | LAT | KW | COP | HC | HE | LAT | KW | DH | COP |
| 30 | 3.9 | 1.4 | 3.2 | 60 | 21.7 | 15.5 | 82.3 | 1.77 | 3.58 | 19.0 | 15.6 | 79.5 | 1.75 | 2.7 | 3.62 |
| | | | | 70 | 21.0 | 14.6 | 91.6 | 1.87 | 3.30 | 18.3 | 14.7 | 88.8 | 1.83 | 2.8 | 3.36 |
| | | | | 80 | 20.4 | 13.8 | 101.0 | 1.96 | 3.05 | 17.5 | 13.8 | 98.0 | 1.92 | 2.9 | 3.11 |
| | 5.4 | 2.6 | 6.0 | 60 | 22.3 | 16.2 | 83.0 | 1.79 | 3.65 | 19.5 | 16.2 | 80.1 | 1.75 | 2.8 | 3.73 |
| | | | | 70 | 21.7 | 15.2 | 92.3 | 1.89 | 3.37 | 18.8 | 15.3 | 89.1 | 1.85 | 2.9 | 3.44 |
| | | | | 80 | 21.1 | 14.3 | 101.7 | 1.98 | 3.12 | 18.1 | 14.4 | 98.7 | 1.94 | 3.0 | 3.19 |
| | 7.0 | 4.1 | 9.6 | 60 | 22.6 | 16.5 | 83.3 | 1.79 | 3.70 | 19.8 | 16.6 | 80.4 | 1.75 | 2.8 | 3.78 |
| | | | | 70 | 22.0 | 15.6 | 92.6 | 1.89 | 3.42 | 19.1 | 13.4 | 89.6 | 1.85 | 2.9 | 3.49 |
| | | | | 80 | 21.4 | 14.6 | 102.0 | 1.98 | 3.17 | 18.4 | 14.7 | 98.9 | 1.94 | 3.0 | 3.23 |
| 50 | 3.9 | 1.3 | 3.0 | 60 | 28.0 | 21.7 | 88.8 | 1.86 | 4.42 | 24.5 | 21.9 | 85.2 | 1.80 | 3.5 | 4.57 |
| | | | | 70 | 27.2 | 20.4 | 98.0 | 1.96 | 4.07 | 23.6 | 20.6 | 94.3 | 1.90 | 3.6 | 4.20 |
| | | | | 80 | 26.3 | 19.2 | 107.0 | 2.05 | 3.75 | 22.6 | 19.4 | 103.2 | 1.99 | 3.7 | 3.86 |
| | 5.4 | 2.4 | 5.5 | 60 | 29.2 | 22.7 | 90.0 | 1.89 | 4.52 | 25.6 | 23.0 | 86.3 | 1.83 | 3.6 | 4.67 |
| | | | | 70 | 28.2 | 21.5 | 99.1 | 1.99 | 4.15 | 24.5 | 21.7 | 95.2 | 1.93 | 3.7 | 4.29 |
| | | | | 80 | 27.3 | 20.1 | 108.1 | 2.10 | 3.82 | 23.5 | 20.4 | 104.2 | 2.03 | 3.8 | 3.95 |
| | 7.0 | 3.9 | 8.9 | 60 | 29.8 | 23.3 | 90.7 | 1.90 | 4.59 | 26.1 | 23.5 | 86.8 | 1.83 | 3.7 | 4.76 |
| | | | | 70 | 28.8 | 22.0 | 99.7 | 2.00 | 4.22 | 25.0 | 22.3 | 95.7 | 1.94 | 3.8 | 4.36 |
| | | | | 80 | 27.9 | 20.7 | 108.7 | 2.10 | 3.88 | 23.9 | 20.9 | 104.6 | 2.04 | 3.9 | 4.01 |
| 70 | 3.9 | 1.3 | 3.0 | 60 | 34.1 | 27.4 | 95.1 | 1.97 | 5.06 | 29.8 | 27.7 | 90.7 | 1.88 | 4.2 | 5.30 |
| | | | | 70 | 32.9 | 25.8 | 103.8 | 2.08 | 4.64 | 28.5 | 26.2 | 99.4 | 1.99 | 4.3 | 4.85 |
| | | | | 80 | 31.7 | 24.2 | 112.6 | 2.18 | 4.26 | 27.2 | 24.6 | 108.0 | 2.08 | 4.4 | 4.45 |
| | 5.4 | 2.3 | 5.3 | 60 | 35.8 | 28.8 | 96.8 | 2.03 | 5.16 | 31.3 | 29.3 | 92.2 | 1.94 | 4.5 | 5.41 |
| | | | | 70 | 34.5 | 27.2 | 105.5 | 2.14 | 4.73 | 30.0 | 27.6 | 100.8 | 2.04 | 4.6 | 4.95 |
| | | | | 80 | 33.3 | 25.6 | 114.2 | 2.25 | 4.33 | 28.6 | 26.0 | 109.4 | 2.15 | 4.7 | 4.54 |
| | 7.0 | 3.7 | 8.5 | 60 | 36.8 | 29.7 | 97.8 | 2.06 | 5.24 | 32.2 | 30.2 | 93.1 | 1.95 | 4.6 | 5.51 |
| | | | | 70 | 35.4 | 28.1 | 106.5 | 2.16 | 4.80 | 30.7 | 28.5 | 101.6 | 2.06 | 4.7 | 5.04 |
| | | | | 80 | 34.1 | 26.4 | 115.1 | 2.27 | 4.40 | 29.3 | 26.8 | 110.2 | 2.16 | 4.8 | 4.62 |
| 90 | 3.9 | 1.2 | 2.8 | 60 | 39.3 | 32.3 | 100.4 | 1.96 | 5.88 | 34.4 | 32.9 | 95.4 | 1.95 | 4.9 | 5.91 |
| | | | | 70 | 37.9 | 30.4 | 108.9 | 2.22 | 5.01 | 32.8 | 31.0 | 103.8 | 2.05 | 5.0 | 5.40 |
| | | | | 80 | 36.4 | 28.6 | 117.4 | 2.28 | 4.68 | 31.3 | 29.1 | 112.2 | 2.16 | 5.1 | 4.94 |
| | 5.4 | 2.1 | 4.9 | 60 | 41.5 | 34.2 | 102.7 | 2.15 | 5.66 | 36.4 | 34.9 | 97.4 | 2.02 | 5.2 | 6.02 |
| | | | | 70 | 40.0 | 32.3 | 111.2 | 2.26 | 5.18 | 34.7 | 33.0 | 105.7 | 2.13 | 5.3 | 5.50 |
| | | | | 80 | 38.5 | 30.4 | 119.6 | 2.38 | 4.74 | 33.1 | 31.0 | 114.0 | 2.24 | 5.4 | 5.03 |
| | 7.0 | 3.4 | 7.9 | 60 | 42.9 | 35.4 | 104.2 | 2.18 | 5.76 | 37.6 | 36.2 | 98.7 | 2.05 | 5.3 | 6.14 |
| | | | | 70 | 41.3 | 33.4 | 112.5 | 2.30 | 5.27 | 35.8 | 34.2 | 106.9 | 2.16 | 5.5 | 5.60 |
| | | | | 80 | 39.7 | 31.4 | 120.8 | 2.41 | 4.82 | 34.1 | 32.1 | 115.1 | 2.27 | 5.6 | 5.12 |

Notes:

1. Capacity data includes water pumping watts and are base upon 15% (by volume) propylene glycol antifreeze solution.
2. Desuperheater Capacity is based upon 0.4 GPM Flow per nominal ton at 90°F entering hot water temperature.
3. The manufacturer reserves the right to make changes in design and construction at any time without notice.
4. Extrapolation data down to 25°F for heating and interpolation between CFM, EWT & GPM data is permissible.
5. See Flow Rate Selection on page 7 for proper application.

GT024 Performance Data: 2.0 Ton, 500 CFM, Low Capacity Heating

| EWT | GPM | WPD | | Heating | | | | | | Heating with Desuperheater | | | | | |
|-----|-----|-----|-----|---------|------|------|-------|------|------|----------------------------|------|-------|------|-----|------|
| | | PSI | FT | EAT | HC | HE | LAT | KW | COP | HC | HE | LAT | KW | DH | COP |
| 30 | 2.2 | 0.9 | 2.1 | 60 | 14.9 | 10.7 | 87.7 | 0.98 | 4.47 | 13.1 | 10.7 | 84.2 | 0.97 | 1.9 | 4.53 |
| | | | | 70 | 14.5 | 10.1 | 96.9 | 1.03 | 4.12 | 12.6 | 10.2 | 93.3 | 1.01 | 1.9 | 4.20 |
| | | | | 80 | 14.1 | 9.5 | 106.0 | 1.08 | 3.81 | 12.1 | 9.5 | 102.4 | 1.06 | 2.0 | 3.89 |
| | 3.1 | 1.7 | 3.9 | 60 | 15.4 | 10.5 | 88.5 | 0.99 | 4.56 | 13.5 | 11.2 | 85.0 | 0.97 | 1.9 | 4.66 |
| | | | | 70 | 15.0 | 10.5 | 97.7 | 1.04 | 4.21 | 13.0 | 10.6 | 94.1 | 1.02 | 2.0 | 4.30 |
| | | | | 80 | 14.6 | 9.9 | 107.0 | 1.09 | 3.90 | 12.5 | 9.9 | 103.2 | 1.07 | 2.0 | 3.99 |
| | 4.0 | 2.7 | 6.2 | 60 | 15.6 | 11.4 | 88.9 | 0.99 | 4.62 | 13.7 | 11.5 | 85.3 | 0.97 | 1.9 | 4.73 |
| | | | | 70 | 15.2 | 10.8 | 98.1 | 1.04 | 4.28 | 13.2 | 9.3 | 94.4 | 1.02 | 2.0 | 4.36 |
| | | | | 80 | 14.8 | 10.1 | 107.4 | 1.09 | 3.96 | 12.7 | 10.2 | 103.5 | 1.07 | 2.1 | 4.04 |
| 50 | 2.2 | 0.8 | 1.9 | 60 | 19.3 | 15.0 | 95.8 | 1.03 | 5.53 | 16.9 | 15.1 | 91.3 | 0.99 | 2.4 | 5.72 |
| | | | | 70 | 18.8 | 14.1 | 104.7 | 1.08 | 5.09 | 16.3 | 14.2 | 100.1 | 1.05 | 2.5 | 5.25 |
| | | | | 80 | 18.1 | 13.3 | 113.5 | 1.13 | 4.69 | 15.6 | 13.4 | 108.8 | 1.10 | 2.5 | 4.83 |
| | 3.1 | 1.6 | 3.6 | 60 | 20.1 | 15.7 | 97.3 | 1.05 | 5.65 | 17.6 | 15.9 | 92.7 | 1.01 | 2.5 | 5.84 |
| | | | | 70 | 19.5 | 14.8 | 106.1 | 1.10 | 5.19 | 16.9 | 14.9 | 101.3 | 1.06 | 2.6 | 5.36 |
| | | | | 80 | 18.9 | 13.9 | 114.9 | 1.16 | 4.78 | 16.2 | 14.1 | 110.0 | 1.12 | 2.6 | 4.94 |
| | 4.0 | 2.5 | 5.8 | 60 | 20.6 | 16.1 | 98.1 | 1.05 | 5.74 | 18.0 | 16.2 | 93.3 | 1.01 | 2.6 | 5.95 |
| | | | | 70 | 19.9 | 15.2 | 106.8 | 1.11 | 5.28 | 17.3 | 15.4 | 102.0 | 1.07 | 2.6 | 5.45 |
| | | | | 80 | 19.2 | 14.3 | 115.6 | 1.16 | 4.85 | 16.5 | 14.4 | 110.6 | 1.12 | 2.7 | 5.01 |
| 70 | 2.2 | 0.8 | 1.9 | 60 | 23.5 | 18.9 | 103.6 | 1.09 | 6.32 | 20.6 | 19.1 | 98.1 | 1.04 | 2.9 | 6.63 |
| | | | | 70 | 22.7 | 17.8 | 112.0 | 1.15 | 5.80 | 19.7 | 18.0 | 106.5 | 1.10 | 3.0 | 6.07 |
| | | | | 80 | 21.8 | 16.7 | 120.5 | 1.20 | 5.32 | 18.8 | 17.0 | 114.8 | 1.15 | 3.1 | 5.57 |
| | 3.1 | 1.5 | 3.5 | 60 | 24.7 | 19.9 | 105.7 | 1.12 | 6.45 | 21.6 | 20.2 | 100.0 | 1.07 | 3.1 | 6.77 |
| | | | | 70 | 23.8 | 18.8 | 114.1 | 1.18 | 5.91 | 20.7 | 19.1 | 108.3 | 1.13 | 3.1 | 6.19 |
| | | | | 80 | 22.9 | 17.6 | 122.5 | 1.24 | 5.41 | 19.7 | 17.9 | 116.5 | 1.18 | 3.2 | 5.68 |
| | 4.0 | 2.4 | 5.5 | 60 | 25.4 | 20.5 | 107.0 | 1.13 | 6.55 | 22.2 | 20.9 | 101.1 | 1.08 | 3.2 | 6.89 |
| | | | | 70 | 24.4 | 19.4 | 115.3 | 1.19 | 6.00 | 21.2 | 19.7 | 109.3 | 1.14 | 3.2 | 6.30 |
| | | | | 80 | 23.5 | 18.2 | 123.6 | 1.25 | 5.50 | 20.2 | 18.5 | 117.5 | 1.19 | 3.3 | 5.78 |
| 90 | 2.2 | 0.8 | 1.8 | 60 | 27.1 | 22.3 | 110.2 | 1.08 | 7.35 | 23.7 | 22.7 | 104.0 | 1.08 | 3.4 | 7.39 |
| | | | | 70 | 26.1 | 21.0 | 118.4 | 1.22 | 6.26 | 22.7 | 21.4 | 112.0 | 1.13 | 3.5 | 6.75 |
| | | | | 80 | 25.1 | 19.7 | 126.5 | 1.26 | 5.85 | 21.6 | 20.1 | 120.0 | 1.19 | 3.5 | 6.18 |
| | 3.1 | 1.4 | 3.2 | 60 | 28.7 | 23.6 | 113.1 | 1.19 | 7.07 | 25.1 | 24.1 | 106.5 | 1.12 | 3.6 | 7.53 |
| | | | | 70 | 27.6 | 22.3 | 121.1 | 1.25 | 6.48 | 24.0 | 22.7 | 114.4 | 1.18 | 3.7 | 6.88 |
| | | | | 80 | 26.5 | 20.9 | 129.1 | 1.31 | 5.92 | 22.8 | 21.4 | 122.2 | 1.24 | 3.7 | 6.29 |
| | 4.0 | 2.2 | 5.1 | 60 | 29.6 | 24.4 | 114.8 | 1.21 | 7.20 | 25.9 | 25.0 | 108.0 | 1.13 | 3.7 | 7.68 |
| | | | | 70 | 28.5 | 23.1 | 122.8 | 1.27 | 6.59 | 24.7 | 23.6 | 115.8 | 1.19 | 3.8 | 7.00 |
| | | | | 80 | 27.4 | 21.7 | 130.7 | 1.33 | 6.03 | 23.5 | 22.2 | 123.6 | 1.25 | 3.8 | 6.40 |

Notes:

- Capacity data includes water pumping watts and are base upon 15% (by volume) propylene glycol antifreeze solution.
- Desuperheater Capacity is based upon 0.4 GPM Flow per nominal ton at 90°F entering hot water temperature.
- The manufacturer reserves the right to make changes in design and construction at any time without notice.
- Extrapolation data down to 25°F for heating and interpolation between CFM, EWT & GPM data is permissible.
- See Flow Rate Selection on page 7 for proper application.

GT024 Performance Data: 2.0 Ton, 900 CFM, High Capacity Cooling

| EWT | GPM | WPD | | EAT DB/ WB | Cooling | | | | | Cooling with Desuperheater | | | | | |
|-----|-----|-----|-----|------------------|---------|------|------|------|------|----------------------------|------|------|------|-----|------|
| | | PSI | FT | | TC | SC | HR | KW | EER | TC | SC | HR | KW | DH | EER |
| 50 | 3.9 | 1.3 | 3.1 | 75/63 | 28.0 | 19.6 | 33.0 | 1.44 | 19.5 | 28.0 | 19.6 | 33.0 | 1.41 | 2.4 | 19.9 |
| | | | | 80/67 | 30.4 | 20.4 | 35.1 | 1.47 | 20.7 | 30.4 | 20.4 | 35.1 | 1.44 | 2.4 | 21.2 |
| | | | | 85/71 | 32.9 | 21.2 | 37.2 | 1.50 | 21.9 | 32.9 | 21.2 | 37.2 | 1.47 | 2.5 | 22.4 |
| | 5.4 | 2.4 | 5.5 | 75/63 | 28.3 | 19.8 | 33.1 | 1.37 | 20.6 | 28.3 | 19.8 | 33.1 | 1.35 | 2.2 | 20.9 |
| | | | | 80/67 | 30.7 | 20.6 | 35.2 | 1.40 | 21.9 | 30.7 | 20.6 | 35.2 | 1.38 | 2.3 | 22.2 |
| | | | | 85/71 | 33.2 | 21.4 | 37.3 | 1.43 | 23.2 | 33.2 | 21.4 | 37.3 | 1.41 | 2.4 | 23.5 |
| | 7.0 | 3.9 | 8.9 | 75/63 | 28.6 | 19.8 | 33.3 | 1.33 | 21.5 | 28.6 | 19.8 | 33.3 | 1.33 | 2.1 | 21.5 |
| | | | | 80/67 | 31.1 | 20.6 | 35.4 | 1.36 | 22.8 | 31.1 | 20.8 | 35.4 | 1.35 | 2.2 | 22.9 |
| | | | | 85/71 | 33.6 | 21.4 | 37.5 | 1.39 | 24.2 | 33.6 | 21.4 | 37.6 | 1.38 | 2.2 | 24.3 |
| 70 | 3.9 | 1.3 | 3.0 | 75/63 | 26.3 | 19.2 | 32.1 | 1.73 | 15.2 | 26.4 | 19.3 | 32.2 | 1.69 | 3.4 | 15.7 |
| | | | | 80/67 | 28.5 | 20.0 | 34.1 | 1.77 | 16.1 | 28.7 | 20.1 | 34.2 | 1.72 | 3.5 | 16.7 |
| | | | | 85/71 | 30.8 | 20.8 | 36.2 | 1.80 | 17.2 | 31.0 | 20.9 | 36.3 | 1.76 | 3.6 | 17.6 |
| | 5.4 | 2.3 | 5.3 | 75/63 | 26.7 | 19.4 | 32.2 | 1.64 | 16.2 | 26.8 | 19.5 | 32.3 | 1.62 | 3.3 | 16.6 |
| | | | | 80/67 | 29.0 | 20.2 | 34.3 | 1.68 | 17.3 | 29.2 | 20.3 | 34.4 | 1.65 | 3.4 | 17.6 |
| | | | | 85/71 | 31.3 | 21.0 | 36.4 | 1.71 | 18.3 | 31.5 | 21.1 | 36.5 | 1.68 | 3.5 | 18.7 |
| | 7.0 | 3.7 | 8.5 | 75/63 | 26.9 | 19.4 | 32.4 | 1.59 | 16.9 | 27.1 | 19.5 | 32.5 | 1.59 | 3.1 | 17.1 |
| | | | | 80/67 | 29.3 | 20.2 | 34.5 | 1.63 | 18.0 | 29.5 | 20.3 | 34.6 | 1.62 | 3.2 | 18.2 |
| | | | | 85/71 | 31.6 | 21.0 | 36.5 | 1.66 | 19.0 | 31.8 | 21.1 | 36.7 | 1.65 | 3.3 | 19.3 |
| 90 | 3.9 | 1.2 | 2.8 | 75/63 | 23.9 | 18.4 | 30.9 | 2.14 | 11.2 | 24.1 | 18.6 | 31.0 | 2.07 | 4.5 | 11.7 |
| | | | | 80/67 | 26.0 | 19.2 | 32.9 | 2.18 | 11.9 | 26.2 | 19.3 | 33.0 | 2.12 | 4.6 | 12.4 |
| | | | | 85/71 | 28.1 | 20.0 | 34.9 | 2.21 | 12.7 | 28.3 | 20.1 | 35.0 | 2.15 | 4.7 | 13.2 |
| | 5.4 | 2.1 | 4.9 | 75/63 | 24.4 | 18.6 | 31.1 | 2.01 | 12.1 | 24.6 | 18.7 | 31.2 | 1.97 | 4.3 | 12.5 |
| | | | | 80/67 | 26.5 | 19.4 | 33.0 | 2.06 | 12.9 | 26.8 | 19.5 | 33.2 | 2.01 | 4.4 | 13.3 |
| | | | | 85/71 | 28.6 | 20.2 | 35.0 | 2.09 | 13.7 | 28.9 | 20.3 | 35.2 | 2.05 | 4.5 | 14.1 |
| | 7.0 | 3.4 | 7.9 | 75/63 | 24.7 | 18.6 | 31.1 | 1.96 | 12.6 | 24.9 | 18.7 | 31.4 | 1.93 | 4.1 | 12.9 |
| | | | | 80/67 | 26.8 | 19.4 | 33.1 | 2.00 | 13.4 | 27.1 | 19.5 | 33.4 | 1.97 | 4.3 | 13.7 |
| | | | | 85/71 | 28.9 | 20.2 | 35.1 | 2.04 | 14.2 | 29.2 | 20.3 | 35.4 | 2.01 | 4.4 | 14.5 |
| 110 | 3.9 | 1.2 | 2.7 | 75/63 | 20.9 | 17.3 | 29.4 | 2.66 | 7.8 | 21.2 | 17.4 | 29.5 | 2.58 | 5.5 | 8.2 |
| | | | | 80/67 | 22.6 | 18.0 | 31.3 | 2.70 | 8.4 | 23.0 | 18.1 | 31.4 | 2.63 | 5.7 | 8.8 |
| | | | | 85/71 | 24.5 | 18.7 | 33.2 | 2.76 | 8.9 | 24.9 | 18.9 | 33.3 | 2.67 | 5.9 | 9.3 |
| | 5.4 | 2.1 | 4.9 | 75/63 | 21.4 | 17.4 | 29.5 | 2.49 | 8.6 | 21.7 | 17.6 | 29.7 | 2.45 | 5.4 | 8.9 |
| | | | | 80/67 | 23.3 | 18.1 | 31.4 | 2.55 | 9.1 | 23.7 | 18.3 | 31.6 | 2.49 | 5.5 | 9.5 |
| | | | | 85/71 | 25.1 | 18.9 | 33.3 | 2.62 | 9.6 | 25.5 | 19.0 | 33.5 | 2.54 | 5.6 | 10.1 |
| | 7.0 | 3.4 | 7.8 | 75/63 | 21.6 | 17.4 | 29.5 | 2.44 | 8.9 | 22.0 | 17.6 | 29.8 | 2.40 | 5.1 | 9.1 |
| | | | | 80/67 | 23.5 | 18.1 | 31.4 | 2.47 | 9.5 | 23.9 | 18.3 | 31.7 | 2.46 | 5.3 | 9.7 |
| | | | | 85/71 | 25.4 | 18.9 | 33.3 | 2.52 | 10.1 | 25.8 | 19.0 | 33.6 | 2.49 | 5.5 | 10.4 |

Notes:

1. Capacity data includes water pumping watts and are base upon 15% (by volume) propylene glycol antifreeze solution.
2. Desuperheater Capacity is based upon 0.4 GPM Flow per nominal ton at 90°F entering hot water temperature.
3. The manufacturer reserves the right to make changes in design and construction at any time without notice.
4. Extrapolation data down to 25°F for heating and interpolation between CFM, EWT & GPM data is permissible.
5. See Flow Rate Selection on page 7 for proper application.

GT024 Performance Data: 2.0 Ton, 500 CFM, Low Capacity Cooling

| EWT | GPM | WPD | | EAT DB/ WB | Cooling | | | | | Cooling with Desuperheater | | | | | |
|-----|-----|-----|-----|------------------|---------|------|------|------|------|----------------------------|------|------|------|-----|------|
| | | PSI | FT | | TC | SC | HR | KW | EER | TC | SC | HR | KW | DH | EER |
| 50 | 2.2 | 0.9 | 2.0 | 75/63 | 19.3 | 13.5 | 22.8 | 0.74 | 26.0 | 19.3 | 13.5 | 22.8 | 0.73 | 1.6 | 26.5 |
| | | | | 80/67 | 21.0 | 14.1 | 24.2 | 0.76 | 27.6 | 21.0 | 14.1 | 24.2 | 0.74 | 1.7 | 28.2 |
| | | | | 85/71 | 22.7 | 14.6 | 25.7 | 0.78 | 29.2 | 22.7 | 14.7 | 25.7 | 0.76 | 1.7 | 29.8 |
| | 3.1 | 1.6 | 3.6 | 75/63 | 19.5 | 13.6 | 22.8 | 0.71 | 27.5 | 19.5 | 13.7 | 22.8 | 0.70 | 1.5 | 27.9 |
| | | | | 80/67 | 21.2 | 14.2 | 24.3 | 0.73 | 29.2 | 21.2 | 14.2 | 24.3 | 0.72 | 1.6 | 29.6 |
| | | | | 85/71 | 22.9 | 14.7 | 25.7 | 0.74 | 31.0 | 22.9 | 14.8 | 25.7 | 0.73 | 1.6 | 31.3 |
| | 4.0 | 2.5 | 5.8 | 75/63 | 19.7 | 13.6 | 23.0 | 0.69 | 28.6 | 19.7 | 13.7 | 23.0 | 0.69 | 1.5 | 28.7 |
| | | | | 80/67 | 21.4 | 14.2 | 24.4 | 0.70 | 30.5 | 21.4 | 14.2 | 24.4 | 0.70 | 1.5 | 30.6 |
| | | | | 85/71 | 23.2 | 14.7 | 25.9 | 0.72 | 32.2 | 23.2 | 14.8 | 25.9 | 0.71 | 1.5 | 32.5 |
| 70 | 2.2 | 0.8 | 1.9 | 75/63 | 18.1 | 13.3 | 22.2 | 0.89 | 20.3 | 18.2 | 13.3 | 22.2 | 0.87 | 2.3 | 20.9 |
| | | | | 80/67 | 19.7 | 13.8 | 23.6 | 0.92 | 21.5 | 19.8 | 13.9 | 22.3 | 0.89 | 2.4 | 22.3 |
| | | | | 85/71 | 21.3 | 14.3 | 25.0 | 0.93 | 22.9 | 21.4 | 14.4 | 25.0 | 0.91 | 2.5 | 23.5 |
| | 3.1 | 1.5 | 3.5 | 75/63 | 18.4 | 13.4 | 22.2 | 0.85 | 21.6 | 18.5 | 13.5 | 22.3 | 0.84 | 2.3 | 22.1 |
| | | | | 80/67 | 20.0 | 13.9 | 23.7 | 0.87 | 23.0 | 20.1 | 14.0 | 23.8 | 0.86 | 2.3 | 23.5 |
| | | | | 85/71 | 21.6 | 14.5 | 25.1 | 0.89 | 24.4 | 21.7 | 14.6 | 25.2 | 0.87 | 2.4 | 25.0 |
| | 4.0 | 2.4 | 5.5 | 75/63 | 18.6 | 13.4 | 22.4 | 0.83 | 22.5 | 18.7 | 13.5 | 22.4 | 0.82 | 2.1 | 22.8 |
| | | | | 80/67 | 20.2 | 13.9 | 23.8 | 0.84 | 24.0 | 20.3 | 14.0 | 23.9 | 0.84 | 2.2 | 24.2 |
| | | | | 85/71 | 21.8 | 14.5 | 25.2 | 0.86 | 25.4 | 21.9 | 14.6 | 25.3 | 0.85 | 2.3 | 25.7 |
| 90 | 2.2 | 0.8 | 1.8 | 75/63 | 16.5 | 12.7 | 21.3 | 1.11 | 14.9 | 16.7 | 12.8 | 21.4 | 1.07 | 3.1 | 15.5 |
| | | | | 80/67 | 17.9 | 13.2 | 22.7 | 1.13 | 15.9 | 18.1 | 13.3 | 22.8 | 1.09 | 3.2 | 16.5 |
| | | | | 85/71 | 19.4 | 13.8 | 24.1 | 1.15 | 16.9 | 19.6 | 13.9 | 24.2 | 1.12 | 3.3 | 17.5 |
| | 3.1 | 1.4 | 3.2 | 75/63 | 16.8 | 12.8 | 21.4 | 1.04 | 16.2 | 17.0 | 12.9 | 21.6 | 1.02 | 3.0 | 16.7 |
| | | | | 80/67 | 18.3 | 13.4 | 22.8 | 1.07 | 17.2 | 18.5 | 13.5 | 22.9 | 1.04 | 3.1 | 17.8 |
| | | | | 85/71 | 19.8 | 13.9 | 24.1 | 1.08 | 18.3 | 20.0 | 14.0 | 24.3 | 1.06 | 3.1 | 18.8 |
| | 4.0 | 2.2 | 5.2 | 75/63 | 17.0 | 12.8 | 21.5 | 0.01 | 16.8 | 17.2 | 12.9 | 21.6 | 1.00 | 2.9 | 17.2 |
| | | | | 80/67 | 18.5 | 13.4 | 22.8 | 0.03 | 17.9 | 18.7 | 13.5 | 23.0 | 1.02 | 2.9 | 18.3 |
| | | | | 85/71 | 20.0 | 13.9 | 24.2 | 0.06 | 18.9 | 20.2 | 14.0 | 24.4 | 1.04 | 3.0 | 19.4 |
| 110 | 2.2 | 0.8 | 1.7 | 75/63 | 14.4 | 11.9 | 20.3 | 1.38 | 10.4 | 14.6 | 12.0 | 10.4 | 1.34 | 3.8 | 10.9 |
| | | | | 80/67 | 15.6 | 12.4 | 21.6 | 1.40 | 11.2 | 15.9 | 12.5 | 21.7 | 1.36 | 3.9 | 11.7 |
| | | | | 85/71 | 16.9 | 12.9 | 22.9 | 1.43 | 11.8 | 17.2 | 13.0 | 23.0 | 1.38 | 4.0 | 12.4 |
| | 3.1 | 1.4 | 3.2 | 75/63 | 14.7 | 12.0 | 20.4 | 1.29 | 11.4 | 15.0 | 12.1 | 20.5 | 1.27 | 3.7 | 11.8 |
| | | | | 80/67 | 16.1 | 12.5 | 21.6 | 1.32 | 12.2 | 16.3 | 12.6 | 21.8 | 1.29 | 3.8 | 12.7 |
| | | | | 85/71 | 17.3 | 13.0 | 23.0 | 1.35 | 12.8 | 17.6 | 13.1 | 23.1 | 1.31 | 3.9 | 13.4 |
| | 4.0 | 2.2 | 5.1 | 75/63 | 14.9 | 12.0 | 20.4 | 1.26 | 11.8 | 15.2 | 12.1 | 20.6 | 1.24 | 3.5 | 12.2 |
| | | | | 80/67 | 16.2 | 12.5 | 21.6 | 1.28 | 12.7 | 16.5 | 12.6 | 21.9 | 1.28 | 3.7 | 12.9 |
| | | | | 85/71 | 17.5 | 13.0 | 23.0 | 1.30 | 13.4 | 17.8 | 13.1 | 23.2 | 1.29 | 3.8 | 13.8 |

Notes:

1. Capacity data includes water pumping watts and are base upon 15% (by volume) propylene glycol antifreeze solution.
2. Desuperheater Capacity is based upon 0.4 GPM Flow per nominal ton at 90°F entering hot water temperature.
3. The manufacturer reserves the right to make changes in design and construction at any time without notice.
4. Extrapolation data down to 25°F for heating and interpolation between CFM, EWT & GPM data is permissible.
5. See Flow Rate Selection on page 7 for proper application.

GT036 Performance Data: 3.0 Ton, 1300 CFM, High Capacity Heating

| EWT | GPM | WPD | | Heating | | | | | | Heating with Desuperheater | | | | | |
|-----|-----|-----|------|---------|------|------|-------|------|------|----------------------------|------|-------|------|-----|------|
| | | PSI | FT | EAT | HC | HE | LAT | KW | COP | HC | HE | LAT | KW | DH | COP |
| 30 | 5.0 | 1.8 | 4.2 | 60 | 30.0 | 21.6 | 81.4 | 2.46 | 3.58 | 26.3 | 21.6 | 78.7 | 2.43 | 3.7 | 3.62 |
| | | | | 70 | 29.2 | 20.3 | 90.8 | 2.59 | 3.30 | 25.3 | 20.4 | 88.0 | 2.55 | 3.9 | 3.36 |
| | | | | 80 | 28.3 | 19.1 | 100.1 | 2.72 | 3.05 | 24.3 | 19.2 | 97.3 | 2.66 | 4.0 | 3.11 |
| | 7.0 | 3.4 | 7.8 | 60 | 31.0 | 22.5 | 82.1 | 2.49 | 3.65 | 27.1 | 22.5 | 79.3 | 2.43 | 3.9 | 3.73 |
| | | | | 70 | 30.1 | 21.1 | 91.4 | 2.62 | 3.37 | 26.1 | 21.3 | 88.6 | 2.56 | 4.0 | 3.44 |
| | | | | 80 | 29.3 | 19.9 | 100.9 | 2.75 | 3.12 | 25.2 | 20.0 | 97.9 | 2.69 | 4.1 | 3.19 |
| | 9.0 | 5.4 | 12.5 | 60 | 31.4 | 22.9 | 82.3 | 2.48 | 3.70 | 27.5 | 23.0 | 79.6 | 2.43 | 3.9 | 3.78 |
| | | | | 70 | 30.5 | 21.6 | 91.8 | 2.62 | 3.42 | 26.5 | 18.6 | 88.9 | 2.56 | 4.0 | 3.49 |
| | | | | 80 | 29.7 | 20.3 | 101.2 | 2.75 | 3.17 | 25.5 | 20.4 | 98.2 | 2.69 | 4.2 | 3.23 |
| 50 | 5.0 | 1.7 | 3.9 | 60 | 38.9 | 30.1 | 87.7 | 2.58 | 4.42 | 34.0 | 30.4 | 84.2 | 2.49 | 4.8 | 4.57 |
| | | | | 70 | 37.7 | 28.4 | 96.9 | 2.72 | 4.07 | 32.7 | 28.6 | 93.3 | 2.63 | 5.0 | 4.20 |
| | | | | 80 | 36.4 | 26.7 | 105.9 | 2.85 | 3.75 | 31.3 | 26.9 | 102.3 | 2.76 | 5.1 | 3.86 |
| | 7.0 | 3.1 | 7.2 | 60 | 40.5 | 31.5 | 88.9 | 2.63 | 4.52 | 35.5 | 31.9 | 85.3 | 2.54 | 5.0 | 4.67 |
| | | | | 70 | 39.5 | 29.8 | 97.9 | 2.77 | 4.15 | 34.0 | 30.0 | 94.2 | 2.68 | 5.2 | 4.29 |
| | | | | 80 | 37.9 | 27.9 | 107.0 | 2.91 | 3.82 | 32.6 | 28.3 | 103.2 | 2.81 | 5.3 | 3.95 |
| | 9.0 | 5.0 | 11.6 | 60 | 41.3 | 32.4 | 89.4 | 2.64 | 4.59 | 36.2 | 32.7 | 85.8 | 2.54 | 5.1 | 4.76 |
| | | | | 70 | 40.0 | 30.5 | 98.5 | 2.78 | 4.22 | 34.7 | 30.9 | 94.7 | 2.69 | 5.3 | 4.36 |
| | | | | 80 | 38.7 | 28.7 | 107.5 | 2.92 | 3.88 | 33.2 | 29.0 | 103.7 | 2.82 | 5.4 | 4.01 |
| 70 | 5.0 | 1.7 | 3.9 | 60 | 47.3 | 38.0 | 93.7 | 2.74 | 5.06 | 41.4 | 38.5 | 89.5 | 2.61 | 5.9 | 5.30 |
| | | | | 70 | 45.6 | 35.8 | 102.5 | 2.88 | 4.64 | 39.6 | 36.3 | 98.2 | 2.76 | 6.0 | 4.85 |
| | | | | 80 | 43.9 | 33.6 | 111.3 | 3.02 | 4.26 | 37.8 | 34.2 | 106.9 | 2.89 | 6.2 | 4.45 |
| | 7.0 | 3.0 | 6.9 | 60 | 49.7 | 40.0 | 95.4 | 2.82 | 5.16 | 43.5 | 40.7 | 91.0 | 2.69 | 6.2 | 5.41 |
| | | | | 70 | 47.9 | 37.8 | 104.1 | 2.97 | 4.73 | 41.6 | 38.3 | 99.6 | 2.84 | 6.3 | 4.95 |
| | | | | 80 | 46.1 | 35.5 | 112.9 | 3.12 | 4.33 | 39.7 | 36.0 | 108.3 | 2.98 | 6.5 | 4.54 |
| | 9.0 | 4.8 | 11.1 | 60 | 51.0 | 41.3 | 96.3 | 2.85 | 5.24 | 44.7 | 42.0 | 91.8 | 2.71 | 6.4 | 5.51 |
| | | | | 70 | 49.2 | 38.9 | 105.0 | 3.00 | 4.80 | 42.7 | 39.6 | 100.4 | 2.86 | 6.5 | 5.04 |
| | | | | 80 | 47.3 | 36.6 | 113.7 | 3.15 | 4.40 | 40.7 | 37.2 | 109.0 | 3.00 | 6.6 | 4.62 |
| 90 | 5.0 | 1.6 | 3.6 | 60 | 54.5 | 44.8 | 98.8 | 2.72 | 5.88 | 47.7 | 45.7 | 94.0 | 2.70 | 6.8 | 5.91 |
| | | | | 70 | 52.5 | 42.2 | 107.4 | 3.07 | 5.01 | 45.6 | 43.0 | 102.5 | 2.85 | 6.9 | 5.40 |
| | | | | 80 | 50.5 | 39.7 | 116.0 | 3.16 | 4.68 | 43.4 | 40.4 | 110.9 | 3.00 | 7.1 | 4.94 |
| | 7.0 | 2.8 | 6.4 | 60 | 57.6 | 47.5 | 101.1 | 2.98 | 5.66 | 50.5 | 48.4 | 95.9 | 2.80 | 7.2 | 6.02 |
| | | | | 70 | 55.5 | 44.8 | 109.6 | 3.14 | 5.18 | 48.2 | 45.7 | 104.3 | 2.96 | 7.3 | 5.50 |
| | | | | 80 | 53.4 | 42.1 | 118.0 | 3.30 | 4.74 | 45.9 | 43.0 | 112.7 | 3.11 | 7.5 | 5.03 |
| | 9.0 | 4.4 | 10.3 | 60 | 59.6 | 49.2 | 102.4 | 3.03 | 5.76 | 52.2 | 50.2 | 97.1 | 2.84 | 7.4 | 6.14 |
| | | | | 70 | 57.3 | 46.4 | 110.8 | 3.19 | 5.27 | 49.7 | 47.4 | 105.4 | 3.00 | 7.6 | 5.60 |
| | | | | 80 | 55.0 | 43.6 | 119.2 | 3.35 | 4.82 | 47.3 | 44.6 | 113.7 | 3.15 | 7.7 | 5.12 |

Notes:

1. Capacity data includes water pumping watts and are base upon 15% (by volume) propylene glycol antifreeze solution.
2. Desuperheater Capacity is based upon 0.4 GPM Flow per nominal ton at 90°F entering hot water temperature.
3. The manufacturer reserves the right to make changes in design and construction at any time without notice.
4. Extrapolation data down to 25°F for heating and interpolation between CFM, EWT & GPM data is permissible.
5. See Flow Rate Selection on page 7 for proper application.

GT036 Performance Data: 3.0 Ton, 900 CFM, Low Capacity Heating

| EWT | GPM | WPD | | Heating | | | | | | Heating with Desuperheater | | | | | |
|-----|-----|-----|-----|---------|------|------|-------|------|------|----------------------------|------|-------|------|-----|------|
| | | PSI | FT | EAT | HC | HE | LAT | KW | COP | HC | HE | LAT | KW | DH | COP |
| 30 | 2.8 | 1.2 | 2.7 | 60 | 20.1 | 14.4 | 80.6 | 1.31 | 4.47 | 17.6 | 14.4 | 78.1 | 1.30 | 2.5 | 4.53 |
| | | | | 70 | 19.5 | 13.6 | 90.1 | 1.38 | 4.12 | 16.9 | 13.6 | 87.4 | 1.36 | 2.6 | 4.20 |
| | | | | 80 | 18.9 | 12.8 | 99.4 | 1.45 | 3.81 | 16.2 | 12.8 | 96.7 | 1.42 | 2.7 | 3.89 |
| | 3.9 | 2.2 | 5.0 | 60 | 20.7 | 15.0 | 81.3 | 1.33 | 4.56 | 18.1 | 15.0 | 78.6 | 1.30 | 2.6 | 4.66 |
| | | | | 70 | 20.1 | 14.1 | 90.7 | 1.40 | 4.21 | 17.4 | 14.2 | 87.9 | 1.37 | 2.7 | 4.30 |
| | | | | 80 | 19.6 | 13.3 | 100.1 | 1.47 | 3.90 | 16.8 | 13.4 | 97.3 | 1.44 | 2.7 | 3.99 |
| | 5.0 | 3.5 | 8.1 | 60 | 20.9 | 15.3 | 81.5 | 1.33 | 4.62 | 18.3 | 15.4 | 78.9 | 1.30 | 2.6 | 4.73 |
| | | | | 70 | 20.4 | 14.5 | 91.0 | 1.40 | 4.28 | 17.7 | 12.4 | 88.2 | 1.37 | 2.7 | 4.36 |
| | | | | 80 | 19.8 | 13.6 | 100.4 | 1.47 | 3.96 | 17.1 | 13.6 | 97.5 | 1.44 | 2.8 | 4.04 |
| 50 | 2.8 | 1.1 | 2.5 | 60 | 26.0 | 20.1 | 86.7 | 1.38 | 5.53 | 22.7 | 20.3 | 83.4 | 1.33 | 3.2 | 5.72 |
| | | | | 70 | 25.2 | 18.9 | 95.9 | 1.45 | 5.09 | 21.8 | 19.1 | 92.5 | 1.40 | 3.3 | 5.25 |
| | | | | 80 | 24.3 | 17.8 | 105.0 | 1.52 | 4.69 | 20.9 | 18.0 | 101.5 | 1.48 | 3.4 | 4.83 |
| | 3.9 | 2.0 | 4.7 | 60 | 27.1 | 21.1 | 87.8 | 1.40 | 5.65 | 23.7 | 21.3 | 84.4 | 1.36 | 3.4 | 5.84 |
| | | | | 70 | 26.2 | 19.9 | 96.9 | 1.48 | 5.19 | 22.7 | 20.1 | 93.4 | 1.43 | 3.5 | 5.36 |
| | | | | 80 | 25.3 | 18.7 | 106.0 | 1.55 | 4.78 | 21.8 | 18.9 | 102.4 | 1.50 | 3.6 | 4.94 |
| | 5.0 | 3.3 | 7.6 | 60 | 27.6 | 21.6 | 88.4 | 1.41 | 5.74 | 24.2 | 21.8 | 84.9 | 1.36 | 3.4 | 5.95 |
| | | | | 70 | 26.7 | 20.4 | 97.5 | 1.48 | 5.28 | 23.2 | 20.6 | 93.9 | 1.44 | 3.5 | 5.45 |
| | | | | 80 | 25.8 | 19.2 | 106.0 | 1.56 | 4.85 | 22.2 | 19.4 | 102.8 | 1.51 | 3.6 | 5.01 |
| 70 | 2.8 | 1.1 | 2.5 | 60 | 31.6 | 25.4 | 92.5 | 1.46 | 6.32 | 27.6 | 25.7 | 88.4 | 1.40 | 3.9 | 6.63 |
| | | | | 70 | 30.5 | 23.9 | 101.3 | 1.54 | 5.80 | 26.4 | 24.2 | 97.2 | 1.47 | 4.0 | 6.07 |
| | | | | 80 | 29.3 | 22.5 | 110.2 | 1.61 | 5.32 | 25.2 | 22.8 | 105.9 | 1.55 | 4.1 | 5.57 |
| | 3.9 | 2.0 | 4.5 | 60 | 33.2 | 26.7 | 94.1 | 1.51 | 6.45 | 29.0 | 27.2 | 89.9 | 1.44 | 4.1 | 6.77 |
| | | | | 70 | 32.0 | 25.2 | 102.9 | 1.59 | 5.91 | 27.8 | 25.6 | 98.6 | 1.51 | 4.2 | 6.19 |
| | | | | 80 | 30.8 | 23.7 | 111.7 | 1.67 | 5.41 | 26.5 | 24.1 | 107.2 | 1.59 | 4.3 | 5.68 |
| | 5.0 | 3.1 | 7.2 | 60 | 34.1 | 27.6 | 95.0 | 1.52 | 6.55 | 29.8 | 28.0 | 90.7 | 1.45 | 4.2 | 6.89 |
| | | | | 70 | 32.8 | 26.0 | 103.8 | 1.60 | 6.00 | 28.5 | 26.4 | 99.3 | 1.53 | 4.3 | 6.30 |
| | | | | 80 | 31.6 | 24.4 | 112.5 | 1.68 | 5.50 | 27.2 | 24.9 | 107.9 | 1.60 | 4.4 | 5.78 |
| 90 | 2.8 | 1.0 | 2.3 | 60 | 36.4 | 29.9 | 97.5 | 1.45 | 7.35 | 31.9 | 30.5 | 92.8 | 1.44 | 4.5 | 7.39 |
| | | | | 70 | 35.1 | 28.2 | 106.1 | 1.64 | 6.26 | 30.4 | 28.7 | 101.3 | 1.52 | 4.6 | 6.75 |
| | | | | 80 | 33.7 | 26.5 | 114.7 | 1.69 | 5.85 | 29.0 | 27.0 | 109.8 | 1.60 | 4.7 | 6.18 |
| | 3.9 | 1.8 | 4.1 | 60 | 38.5 | 31.7 | 99.6 | 1.59 | 7.07 | 33.7 | 32.3 | 94.7 | 1.50 | 4.8 | 7.53 |
| | | | | 70 | 37.1 | 29.9 | 108.1 | 1.68 | 6.48 | 32.2 | 30.5 | 103.1 | 1.58 | 4.9 | 6.88 |
| | | | | 80 | 35.6 | 28.1 | 116.6 | 1.76 | 5.92 | 30.6 | 28.7 | 111.5 | 1.66 | 5.0 | 6.29 |
| | 5.0 | 2.9 | 6.7 | 60 | 39.8 | 32.8 | 100.9 | 1.62 | 7.20 | 34.8 | 33.5 | 95.8 | 1.52 | 5.0 | 7.68 |
| | | | | 70 | 38.3 | 31.0 | 109.4 | 1.70 | 6.59 | 33.2 | 31.7 | 104.2 | 1.60 | 5.1 | 7.00 |
| | | | | 80 | 36.7 | 29.1 | 117.8 | 1.79 | 6.03 | 31.6 | 29.8 | 112.5 | 1.68 | 5.2 | 6.40 |

Notes:

- Capacity data includes water pumping watts and are base upon 15% (by volume) propylene glycol antifreeze solution.
- Desuperheater Capacity is based upon 0.4 GPM Flow per nominal ton at 90°F entering hot water temperature.
- The manufacturer reserves the right to make changes in design and construction at any time without notice.
- Extrapolation data down to 25°F for heating and interpolation between CFM, EWT & GPM data is permissible.
- See Flow Rate Selection on page 7 for proper application.

GT036 Performance Data: 3.0 Ton, 1300 CFM, High Capacity Cooling

| EWT | GPM | WPD | | EAT DB/ WB | Cooling | | | | | Cooling with Desuperheater | | | | | |
|-----|-----|-----|------|------------------|---------|------|------|------|------|----------------------------|------|------|------|-----|------|
| | | PSI | FT | | TC | SC | HR | KW | EER | TC | SC | HR | KW | DH | EER |
| 50 | 5.0 | 1.7 | 4.0 | 75/63 | 38.9 | 27.2 | 45.8 | 1.99 | 19.5 | 38.9 | 27.2 | 45.8 | 1.96 | 3.3 | 19.9 |
| | | | | 80/67 | 42.2 | 28.3 | 48.7 | 2.04 | 20.7 | 42.2 | 28.3 | 48.7 | 1.99 | 3.4 | 21.2 |
| | | | | 85/71 | 45.6 | 29.4 | 51.6 | 2.08 | 21.9 | 45.6 | 29.5 | 51.6 | 2.04 | 3.4 | 22.4 |
| | 7.0 | 3.1 | 7.2 | 75/63 | 39.3 | 27.4 | 45.9 | 1.91 | 20.6 | 39.3 | 27.5 | 45.9 | 1.88 | 3.1 | 20.9 |
| | | | | 80/67 | 42.6 | 28.5 | 48.8 | 1.95 | 21.9 | 42.6 | 28.6 | 48.9 | 1.92 | 3.2 | 22.2 |
| | | | | 85/71 | 46.1 | 29.7 | 51.8 | 1.98 | 23.2 | 46.1 | 29.7 | 51.8 | 1.96 | 3.3 | 23.5 |
| | 9.0 | 5.0 | 11.6 | 75/63 | 39.7 | 27.4 | 46.2 | 1.85 | 21.5 | 39.7 | 27.5 | 46.2 | 1.84 | 3.0 | 21.5 |
| | | | | 80/67 | 43.1 | 28.5 | 49.1 | 1.89 | 22.8 | 43.1 | 28.6 | 49.1 | 1.88 | 3.0 | 22.9 |
| | | | | 85/71 | 46.6 | 29.7 | 52.0 | 1.93 | 24.2 | 46.6 | 29.7 | 52.1 | 1.91 | 3.1 | 24.3 |
| 70 | 5.0 | 1.7 | 3.9 | 75/63 | 36.5 | 26.7 | 44.6 | 2.40 | 15.2 | 36.7 | 26.7 | 44.6 | 2.34 | 4.7 | 15.7 |
| | | | | 80/67 | 39.6 | 27.7 | 47.4 | 2.45 | 16.1 | 39.8 | 27.9 | 47.5 | 2.39 | 4.9 | 16.7 |
| | | | | 85/71 | 42.8 | 28.9 | 50.3 | 2.49 | 17.2 | 43.0 | 29.0 | 50.3 | 2.44 | 5.0 | 17.6 |
| | 7.0 | 3.0 | 6.9 | 75/63 | 37.0 | 26.9 | 44.7 | 2.28 | 16.2 | 37.2 | 27.1 | 44.9 | 2.24 | 4.6 | 16.6 |
| | | | | 80/67 | 40.2 | 28.1 | 47.6 | 2.33 | 17.3 | 40.5 | 28.2 | 47.8 | 2.30 | 4.7 | 17.6 |
| | | | | 85/71 | 43.4 | 29.2 | 50.5 | 2.38 | 18.3 | 43.7 | 29.3 | 50.7 | 2.33 | 4.8 | 18.7 |
| | 9.0 | 4.8 | 11.1 | 75/63 | 37.3 | 26.9 | 45.0 | 2.21 | 16.9 | 37.6 | 27.1 | 45.1 | 2.20 | 4.3 | 17.1 |
| | | | | 80/67 | 40.6 | 28.1 | 47.8 | 2.26 | 18.0 | 40.9 | 28.2 | 48.0 | 2.25 | 4.5 | 18.2 |
| | | | | 85/71 | 43.8 | 29.2 | 50.7 | 2.30 | 19.0 | 44.1 | 29.3 | 50.9 | 2.28 | 4.6 | 19.3 |
| 90 | 5.0 | 1.6 | 3.6 | 75/63 | 33.2 | 25.6 | 42.9 | 2.96 | 11.2 | 33.5 | 25.8 | 43.0 | 2.87 | 6.2 | 11.7 |
| | | | | 80/67 | 36.1 | 26.6 | 45.6 | 3.02 | 11.9 | 36.4 | 26.8 | 45.8 | 2.94 | 6.4 | 12.4 |
| | | | | 85/71 | 38.9 | 27.7 | 48.4 | 3.07 | 12.7 | 39.3 | 27.9 | 48.6 | 2.99 | 6.5 | 13.2 |
| | 7.0 | 2.8 | 6.4 | 75/63 | 33.8 | 25.8 | 43.1 | 2.79 | 12.1 | 34.1 | 26.0 | 43.4 | 2.73 | 6.0 | 12.5 |
| | | | | 80/67 | 36.8 | 26.9 | 45.8 | 2.86 | 12.9 | 37.1 | 27.1 | 46.1 | 2.78 | 6.1 | 13.3 |
| | | | | 85/71 | 39.8 | 28.0 | 48.6 | 2.90 | 13.7 | 40.1 | 28.2 | 48.9 | 2.85 | 6.3 | 14.1 |
| | 9.0 | 4.5 | 10.3 | 75/63 | 34.2 | 25.8 | 43.2 | 2.72 | 12.6 | 34.6 | 26.0 | 43.5 | 2.68 | 5.7 | 12.9 |
| | | | | 80/67 | 37.2 | 26.9 | 45.9 | 2.77 | 13.4 | 37.5 | 27.1 | 46.3 | 2.74 | 5.9 | 13.7 |
| | | | | 85/71 | 40.2 | 28.0 | 48.7 | 2.83 | 14.2 | 40.5 | 28.2 | 49.1 | 2.79 | 6.1 | 14.5 |
| 110 | 5.0 | 1.5 | 3.5 | 75/63 | 28.9 | 24.0 | 40.8 | 3.69 | 7.8 | 29.4 | 24.2 | 40.9 | 3.58 | 7.7 | 8.2 |
| | | | | 80/67 | 31.4 | 24.9 | 43.4 | 3.74 | 8.4 | 31.9 | 25.1 | 43.6 | 3.64 | 7.9 | 8.8 |
| | | | | 85/71 | 34.0 | 25.9 | 46.0 | 3.84 | 8.9 | 34.6 | 26.2 | 46.2 | 3.70 | 8.1 | 9.3 |
| | 7.0 | 2.8 | 6.4 | 75/63 | 29.7 | 24.2 | 41.0 | 3.46 | 8.6 | 30.2 | 24.4 | 41.2 | 3.40 | 7.4 | 8.9 |
| | | | | 80/67 | 32.3 | 25.2 | 43.5 | 3.53 | 9.1 | 32.8 | 25.4 | 43.8 | 3.45 | 7.7 | 9.5 |
| | | | | 85/71 | 34.9 | 26.2 | 46.2 | 3.63 | 9.6 | 35.5 | 26.4 | 46.5 | 3.52 | 7.8 | 10.1 |
| | 9.0 | 4.4 | 10.1 | 75/63 | 30.0 | 24.2 | 41.0 | 3.38 | 8.9 | 30.5 | 24.4 | 41.3 | 3.33 | 7.1 | 9.1 |
| | | | | 80/67 | 32.6 | 25.2 | 43.5 | 3.43 | 9.5 | 33.2 | 25.4 | 44.0 | 3.42 | 7.3 | 9.7 |
| | | | | 85/71 | 35.2 | 26.2 | 46.2 | 3.49 | 10.1 | 35.8 | 26.4 | 46.6 | 3.46 | 7.6 | 10.4 |

Notes:

1. Capacity data includes water pumping watts and are base upon 15% (by volume) propylene glycol antifreeze solution.
2. Desuperheater Capacity is based upon 0.4 GPM Flow per nominal ton at 90°F entering hot water temperature.
3. The manufacturer reserves the right to make changes in design and construction at any time without notice.
4. Extrapolation data down to 25°F for heating and interpolation between CFM, EWT & GPM data is permissible.
5. See Flow Rate Selection on page 7 for proper application.

GT036 Performance Data: 3.0 Ton, 900 CFM, Low Capacity Cooling

| EWT | GPM | WPD | | EAT DB/ WB | Cooling | | | | | Cooling with Desuperheater | | | | | |
|-----|-----|-----|-----|------------------|---------|------|------|------|------|----------------------------|------|------|------|-----|------|
| | | PSI | FT | | TC | SC | HR | KW | EER | TC | SC | HR | KW | DH | EER |
| 50 | 2.8 | 1.1 | 2.6 | 75/63 | 25.9 | 18.1 | 30.6 | 1.00 | 26.0 | 25.9 | 18.2 | 30.6 | 0.98 | 2.2 | 26.5 |
| | | | | 80/67 | 28.2 | 18.9 | 32.5 | 1.02 | 27.6 | 28.2 | 18.9 | 32.5 | 1.00 | 2.2 | 28.2 |
| | | | | 85/71 | 30.4 | 19.6 | 34.5 | 1.04 | 29.2 | 30.4 | 19.7 | 34.5 | 1.02 | 2.3 | 29.8 |
| | 3.9 | 2.0 | 4.7 | 75/63 | 26.2 | 18.3 | 30.7 | 0.95 | 27.5 | 26.2 | 18.3 | 30.7 | 0.94 | 2.1 | 27.9 |
| | | | | 80/67 | 28.5 | 19.0 | 32.6 | 0.97 | 29.2 | 28.5 | 19.1 | 32.6 | 0.96 | 2.1 | 29.6 |
| | | | | 85/71 | 30.8 | 19.8 | 34.6 | 0.99 | 31.0 | 30.8 | 19.8 | 34.6 | 0.98 | 2.2 | 31.3 |
| | 5.0 | 3.3 | 7.6 | 75/63 | 26.5 | 18.3 | 30.8 | 0.93 | 28.6 | 26.5 | 18.3 | 30.8 | 0.92 | 2.0 | 28.7 |
| | | | | 80/67 | 28.8 | 19.0 | 32.8 | 0.94 | 30.5 | 28.8 | 19.1 | 32.8 | 0.94 | 2.0 | 30.6 |
| | | | | 85/71 | 31.1 | 19.8 | 34.7 | 0.97 | 32.2 | 31.1 | 19.8 | 34.8 | 0.96 | 2.1 | 32.5 |
| 70 | 2.8 | 1.1 | 2.5 | 75/63 | 24.3 | 17.8 | 29.7 | 1.20 | 20.3 | 24.5 | 17.8 | 29.8 | 1.17 | 3.1 | 20.5 |
| | | | | 80/67 | 26.4 | 18.5 | 31.6 | 1.23 | 21.5 | 26.6 | 18.6 | 31.7 | 1.19 | 3.3 | 22.3 |
| | | | | 85/71 | 28.6 | 19.3 | 33.5 | 1.25 | 22.9 | 28.7 | 19.3 | 33.6 | 1.22 | 3.4 | 23.5 |
| | 3.9 | 2.0 | 4.5 | 75/63 | 24.7 | 18.0 | 29.9 | 1.14 | 21.6 | 24.9 | 18.1 | 30.0 | 1.12 | 3.0 | 22.1 |
| | | | | 80/67 | 26.9 | 18.7 | 31.8 | 1.17 | 23.0 | 27.0 | 18.8 | 31.9 | 1.15 | 3.1 | 23.5 |
| | | | | 85/71 | 29.0 | 19.5 | 33.7 | 1.19 | 24.4 | 29.2 | 19.6 | 33.8 | 1.17 | 3.2 | 25.0 |
| | 5.0 | 3.1 | 7.2 | 75/63 | 24.9 | 18.0 | 30.0 | 1.11 | 22.5 | 25.1 | 18.1 | 30.1 | 1.10 | 2.9 | 22.8 |
| | | | | 80/67 | 27.1 | 18.7 | 31.9 | 1.13 | 24.0 | 27.3 | 18.8 | 32.1 | 1.13 | 3.0 | 24.2 |
| | | | | 85/71 | 29.3 | 19.5 | 33.8 | 1.15 | 25.4 | 29.4 | 19.6 | 34.0 | 1.14 | 3.1 | 25.7 |
| 90 | 2.8 | 1.0 | 2.3 | 75/63 | 22.2 | 17.1 | 28.6 | 1.48 | 14.9 | 22.4 | 17.2 | 28.7 | 1.44 | 4.2 | 15.5 |
| | | | | 80/67 | 24.1 | 17.8 | 30.4 | 1.51 | 15.9 | 24.3 | 17.9 | 30.6 | 1.47 | 4.3 | 16.5 |
| | | | | 85/71 | 26.0 | 18.5 | 32.3 | 1.54 | 16.9 | 26.3 | 18.6 | 32.4 | 1.50 | 4.4 | 17.5 |
| | 3.9 | 1.8 | 4.2 | 75/63 | 22.6 | 17.2 | 28.8 | 1.40 | 16.2 | 22.8 | 17.4 | 28.9 | 1.37 | 4.0 | 16.7 |
| | | | | 80/67 | 24.6 | 18.0 | 30.6 | 1.43 | 17.2 | 24.8 | 18.1 | 30.8 | 1.39 | 4.1 | 17.8 |
| | | | | 85/71 | 26.5 | 18.7 | 32.4 | 1.45 | 18.3 | 26.8 | 18.8 | 32.6 | 1.43 | 4.2 | 18.8 |
| | 5.0 | 2.9 | 6.7 | 75/63 | 22.8 | 17.2 | 28.8 | 1.36 | 16.8 | 23.1 | 17.4 | 29.1 | 1.34 | 3.8 | 17.2 |
| | | | | 80/67 | 24.8 | 18.0 | 30.7 | 1.39 | 17.9 | 25.1 | 18.1 | 30.9 | 1.37 | 3.9 | 18.3 |
| | | | | 85/71 | 26.8 | 18.7 | 32.5 | 1.42 | 18.9 | 27.1 | 18.8 | 32.8 | 1.40 | 4.1 | 19.4 |
| 110 | 2.8 | 1.0 | 2.3 | 75/63 | 19.3 | 16.0 | 27.2 | 1.85 | 10.4 | 19.6 | 16.1 | 27.3 | 1.79 | 5.1 | 10.9 |
| | | | | 80/67 | 21.0 | 16.6 | 29.0 | 1.87 | 11.2 | 21.3 | 16.8 | 29.1 | 1.82 | 5.3 | 11.7 |
| | | | | 85/71 | 22.7 | 17.3 | 30.7 | 1.92 | 11.8 | 23.1 | 17.5 | 30.8 | 1.86 | 5.4 | 12.4 |
| | 3.9 | 1.8 | 4.1 | 75/63 | 19.8 | 16.2 | 27.3 | 1.73 | 11.4 | 20.1 | 16.3 | 27.5 | 1.70 | 5.0 | 11.8 |
| | | | | 80/67 | 21.6 | 16.8 | 29.1 | 1.77 | 12.2 | 21.9 | 16.9 | 29.3 | 1.73 | 5.1 | 12.7 |
| | | | | 85/71 | 23.3 | 17.5 | 30.8 | 1.82 | 12.8 | 23.7 | 17.6 | 31.0 | 1.76 | 5.2 | 13.4 |
| | 5.0 | 2.8 | 6.6 | 75/63 | 20.0 | 16.2 | 27.3 | 1.69 | 11.8 | 20.3 | 16.3 | 27.6 | 1.67 | 4.7 | 12.2 |
| | | | | 80/67 | 21.8 | 16.8 | 29.1 | 1.72 | 12.7 | 22.1 | 16.9 | 29.4 | 1.71 | 4.9 | 12.9 |
| | | | | 85/71 | 23.5 | 17.5 | 30.8 | 1.75 | 13.4 | 23.9 | 17.6 | 31.1 | 1.73 | 5.1 | 13.8 |

Notes:

- Capacity data includes water pumping watts and are base upon 15% (by volume) propylene glycol antifreeze solution.
- Desuperheater Capacity is based upon 0.4 GPM Flow per nominal ton at 90°F entering hot water temperature.
- The manufacturer reserves the right to make changes in design and construction at any time without notice.
- Extrapolation data down to 25°F for heating and interpolation between CFM, EWT & GPM data is permissible.
- See Flow Rate Selection on page 7 for proper application.

GT048 Performance Data: 4.0 Ton, 1700 CFM, High Capacity Heating

| EWT | GPM | WPD | | Heating | | | | | | Heating with Desuperheater | | | | | |
|-----|------|-----|------|---------|------|------|-------|------|------|----------------------------|------|-------|------|------|------|
| | | PSI | FT | EAT | HC | HE | LAT | KW | COP | HC | HE | LAT | KW | DH | COP |
| 30 | 6.7 | 2.2 | 5.0 | 60 | 43.6 | 31.3 | 83.8 | 3.68 | 3.48 | 38.2 | 31.4 | 80.8 | 3.63 | 5.4 | 3.52 |
| | | | | 70 | 42.4 | 29.5 | 93.1 | 3.87 | 3.21 | 36.8 | 29.7 | 90.0 | 3.80 | 5.6 | 3.27 |
| | | | | 80 | 41.1 | 27.8 | 102.4 | 4.06 | 2.97 | 35.3 | 27.8 | 99.2 | 3.98 | 5.8 | 3.03 |
| | 9.3 | 4.0 | 9.3 | 60 | 45.0 | 32.7 | 84.5 | 3.71 | 3.55 | 39.4 | 32.7 | 81.4 | 3.63 | 5.6 | 3.63 |
| | | | | 70 | 43.7 | 30.7 | 93.8 | 3.91 | 3.28 | 38.0 | 30.9 | 90.7 | 3.83 | 5.8 | 3.35 |
| | | | | 80 | 42.5 | 28.9 | 103.2 | 4.11 | 3.03 | 36.6 | 29.1 | 99.9 | 4.02 | 6.0 | 3.10 |
| | 12.0 | 6.5 | 15.0 | 60 | 45.6 | 33.3 | 84.8 | 3.71 | 3.60 | 39.9 | 33.5 | 81.7 | 3.63 | 5.7 | 3.68 |
| | | | | 70 | 44.4 | 31.4 | 94.2 | 3.91 | 3.33 | 38.5 | 27.0 | 91.0 | 3.83 | 5.7 | 3.39 |
| | | | | 80 | 43.2 | 29.5 | 103.5 | 4.10 | 3.08 | 37.1 | 29.7 | 100.2 | 4.03 | 6.1 | 3.14 |
| 50 | 6.7 | 2.0 | 4.7 | 60 | 56.5 | 43.8 | 90.8 | 3.85 | 4.30 | 49.4 | 44.1 | 86.9 | 3.72 | 7.0 | 4.45 |
| | | | | 70 | 54.8 | 41.2 | 99.8 | 4.06 | 3.96 | 47.5 | 41.6 | 95.9 | 3.93 | 7.2 | 4.09 |
| | | | | 80 | 52.9 | 38.8 | 108.8 | 4.25 | 3.65 | 45.5 | 39.1 | 104.8 | 4.13 | 7.4 | 3.75 |
| | 9.3 | 3.7 | 8.6 | 60 | 58.9 | 45.8 | 92.1 | 3.93 | 4.39 | 51.5 | 46.3 | 88.1 | 3.80 | 7.3 | 4.54 |
| | | | | 70 | 56.9 | 43.3 | 101.0 | 4.13 | 4.03 | 49.4 | 43.6 | 96.9 | 4.00 | 7.5 | 4.17 |
| | | | | 80 | 55.1 | 40.6 | 110.0 | 4.35 | 3.71 | 47.4 | 41.1 | 105.8 | 4.20 | 7.7 | 3.84 |
| | 12.0 | 6.0 | 14.0 | 60 | 60.1 | 47.0 | 92.7 | 3.94 | 4.46 | 52.6 | 47.4 | 88.6 | 3.80 | 7.5 | 4.63 |
| | | | | 70 | 58.1 | 44.4 | 101.7 | 4.15 | 4.10 | 50.4 | 44.9 | 97.5 | 4.02 | 7.7 | 4.24 |
| | | | | 80 | 56.2 | 41.7 | 110.6 | 4.36 | 3.77 | 48.3 | 42.2 | 106.3 | 4.22 | 7.9 | 3.90 |
| 70 | 6.7 | 2.0 | 4.7 | 60 | 68.7 | 55.2 | 97.4 | 4.09 | 4.92 | 60.2 | 55.9 | 92.8 | 3.91 | 8.6 | 5.16 |
| | | | | 70 | 66.3 | 52.0 | 106.1 | 4.31 | 4.51 | 57.5 | 52.7 | 101.3 | 4.12 | 8.8 | 4.72 |
| | | | | 80 | 63.8 | 48.9 | 114.8 | 4.52 | 4.14 | 54.9 | 49.7 | 109.9 | 4.32 | 9.0 | 4.33 |
| | 9.3 | 3.6 | 8.3 | 60 | 72.1 | 58.1 | 99.3 | 4.21 | 5.02 | 63.2 | 59.1 | 94.4 | 4.02 | 9.0 | 5.26 |
| | | | | 70 | 69.6 | 54.8 | 107.9 | 4.43 | 4.60 | 60.4 | 55.7 | 102.9 | 4.24 | 9.2 | 4.81 |
| | | | | 80 | 67.0 | 51.5 | 116.5 | 4.67 | 4.21 | 57.6 | 52.4 | 111.4 | 4.45 | 9.4 | 4.42 |
| | 12.0 | 5.8 | 13.3 | 60 | 74.1 | 60.0 | 100.4 | 4.26 | 5.09 | 64.9 | 60.9 | 95.3 | 4.05 | 9.2 | 5.36 |
| | | | | 70 | 71.4 | 56.5 | 108.9 | 4.49 | 4.67 | 62.0 | 57.5 | 103.8 | 4.27 | 9.4 | 4.90 |
| | | | | 80 | 68.7 | 53.1 | 117.4 | 4.71 | 4.28 | 59.1 | 54.1 | 112.2 | 4.48 | 9.7 | 4.49 |
| 90 | 6.7 | 1.9 | 4.3 | 60 | 79.2 | 65.1 | 103.1 | 4.06 | 5.72 | 69.4 | 66.3 | 97.8 | 4.04 | 9.9 | 5.75 |
| | | | | 70 | 76.3 | 61.3 | 111.6 | 4.59 | 4.87 | 66.2 | 62.5 | 106.1 | 4.26 | 10.1 | 5.25 |
| | | | | 80 | 73.4 | 57.6 | 120.0 | 4.73 | 4.55 | 63.1 | 58.7 | 114.3 | 4.47 | 10.3 | 4.80 |
| | 9.3 | 3.3 | 7.7 | 60 | 83.7 | 69.0 | 105.6 | 4.46 | 5.50 | 73.3 | 70.4 | 99.9 | 4.19 | 10.4 | 5.86 |
| | | | | 70 | 80.7 | 65.1 | 113.9 | 4.70 | 5.04 | 70.0 | 66.5 | 108.1 | 4.42 | 10.7 | 5.35 |
| | | | | 80 | 77.5 | 61.2 | 122.2 | 4.93 | 4.61 | 66.6 | 62.4 | 116.3 | 4.64 | 10.9 | 4.89 |
| | 12.0 | 5.3 | 12.3 | 60 | 86.5 | 71.4 | 107.1 | 4.53 | 5.60 | 75.8 | 72.9 | 101.3 | 4.25 | 10.8 | 5.97 |
| | | | | 70 | 83.2 | 67.4 | 115.3 | 4.76 | 5.12 | 72.2 | 68.9 | 109.3 | 4.48 | 11.0 | 5.45 |
| | | | | 80 | 79.9 | 63.4 | 123.5 | 5.00 | 4.69 | 68.7 | 64.7 | 117.4 | 4.70 | 11.2 | 4.98 |

Notes:

1. Capacity data includes water pumping watts and are base upon 15% (by volume) propylene glycol antifreeze solution.
2. Desuperheater Capacity is based upon 0.4 GPM Flow per nominal ton at 90°F entering hot water temperature.
3. The manufacturer reserves the right to make changes in design and construction at any time without notice.
4. Extrapolation data down to 25°F for heating and interpolation between CFM, EWT & GPM data is permissible.
5. See Flow Rate Selection on page 7 for proper application.

GT048 Performance Data: 4.0 Ton, 1100 CFM, Low Capacity Heating

| EWT | GPM | WPD | | Heating | | | | | | Heating with Desuperheater | | | | | |
|-----|-----|-----|-----|---------|------|------|-------|------|------|----------------------------|------|-------|------|-----|------|
| | | PSI | FT | EAT | HC | HE | LAT | KW | COP | HC | HE | LAT | KW | DH | COP |
| 30 | 3.9 | 1.4 | 3.2 | 60 | 29.0 | 20.8 | 84.4 | 1.98 | 4.28 | 25.4 | 20.8 | 81.3 | 1.96 | 3.6 | 4.33 |
| | | | | 70 | 28.1 | 19.6 | 93.7 | 2.09 | 3.94 | 24.4 | 19.7 | 90.6 | 2.05 | 3.7 | 4.02 |
| | | | | 80 | 27.3 | 18.4 | 102.9 | 2.19 | 3.64 | 23.4 | 18.5 | 99.7 | 2.15 | 3.8 | 3.72 |
| | 5.4 | 2.6 | 6.0 | 60 | 29.8 | 21.7 | 85.1 | 2.01 | 4.36 | 26.1 | 21.7 | 82.0 | 1.96 | 3.7 | 4.46 |
| | | | | 70 | 29.0 | 20.4 | 94.4 | 2.11 | 4.03 | 25.2 | 20.5 | 91.2 | 2.07 | 3.8 | 4.11 |
| | | | | 80 | 28.2 | 19.2 | 103.8 | 2.22 | 3.73 | 24.3 | 19.3 | 100.4 | 2.17 | 4.0 | 3.81 |
| | 7.0 | 4.1 | 9.6 | 60 | 30.2 | 22.1 | 85.4 | 2.00 | 4.42 | 26.5 | 22.2 | 82.3 | 1.96 | 3.8 | 4.52 |
| | | | | 70 | 29.4 | 20.9 | 94.8 | 2.11 | 4.09 | 25.5 | 17.9 | 91.5 | 2.07 | 3.9 | 4.17 |
| | | | | 80 | 28.6 | 19.6 | 104.1 | 2.22 | 3.79 | 24.6 | 19.7 | 100.7 | 2.17 | 4.0 | 3.86 |
| 50 | 3.9 | 1.3 | 3.0 | 60 | 37.5 | 29.0 | 91.5 | 2.08 | 5.28 | 37.5 | 29.3 | 87.6 | 2.01 | 4.7 | 5.46 |
| | | | | 70 | 36.3 | 27.3 | 100.6 | 2.19 | 4.86 | 36.0 | 27.6 | 96.5 | 2.12 | 4.8 | 5.02 |
| | | | | 80 | 35.1 | 25.7 | 109.6 | 2.30 | 4.48 | 34.5 | 25.9 | 105.4 | 2.23 | 4.9 | 4.61 |
| | 5.4 | 2.4 | 5.5 | 60 | 39.1 | 30.4 | 92.9 | 2.12 | 5.40 | 34.2 | 30.7 | 88.8 | 2.05 | 4.9 | 5.58 |
| | | | | 70 | 37.8 | 28.7 | 101.8 | 2.23 | 4.96 | 32.8 | 29.0 | 97.6 | 2.16 | 5.0 | 5.13 |
| | | | | 80 | 36.5 | 26.9 | 110.8 | 2.35 | 4.56 | 31.4 | 27.2 | 106.4 | 2.27 | 5.1 | 4.72 |
| | 7.0 | 3.9 | 8.9 | 60 | 39.8 | 31.2 | 93.5 | 2.13 | 5.48 | 34.9 | 31.5 | 89.4 | 2.05 | 5.0 | 5.69 |
| | | | | 70 | 38.6 | 29.4 | 102.5 | 2.24 | 5.04 | 33.5 | 29.8 | 98.2 | 2.17 | 5.1 | 5.21 |
| | | | | 80 | 37.3 | 27.7 | 111.4 | 2.36 | 4.63 | 32.0 | 28.0 | 107.0 | 2.28 | 5.2 | 4.79 |
| 70 | 3.9 | 1.3 | 3.0 | 60 | 45.6 | 36.6 | 98.4 | 2.21 | 6.04 | 39.9 | 37.1 | 93.6 | 2.11 | 5.7 | 6.33 |
| | | | | 70 | 44.0 | 34.5 | 107.0 | 2.33 | 5.54 | 38.2 | 35.0 | 102.1 | 2.22 | 5.8 | 5.80 |
| | | | | 80 | 42.3 | 32.4 | 115.6 | 2.44 | 5.09 | 36.4 | 32.9 | 110.6 | 2.33 | 5.9 | 5.32 |
| | 5.4 | 2.3 | 5.3 | 60 | 47.9 | 38.6 | 100.3 | 2.28 | 6.16 | 41.9 | 39.2 | 95.3 | 2.17 | 6.0 | 6.46 |
| | | | | 70 | 46.2 | 36.4 | 108.9 | 2.39 | 5.65 | 40.1 | 36.9 | 103.7 | 2.29 | 6.1 | 5.92 |
| | | | | 80 | 44.5 | 34.2 | 117.4 | 2.52 | 5.17 | 38.02 | 34.7 | 112.2 | 2.40 | 6.2 | 5.43 |
| | 7.0 | 3.7 | 8.5 | 60 | 49.2 | 39.8 | 101.4 | 2.30 | 6.26 | 43.0 | 40.4 | 96.2 | 2.19 | 6.1 | 6.58 |
| | | | | 70 | 47.4 | 37.5 | 109.9 | 2.42 | 5.73 | 41.1 | 38.1 | 104.6 | 2.31 | 6.3 | 6.02 |
| | | | | 80 | 45.6 | 35.3 | 118.4 | 2.54 | 5.26 | 39.2 | 35.9 | 113.0 | 2.42 | 6.4 | 5.52 |
| 90 | 3.9 | 1.2 | 2.8 | 60 | 52.6 | 43.2 | 104.2 | 2.19 | 7.02 | 46.0 | 44.0 | 98.7 | 2.18 | 6.5 | 7.06 |
| | | | | 70 | 50.6 | 40.7 | 112.6 | 2.48 | 5.98 | 43.9 | 41.5 | 107.0 | 2.30 | 6.7 | 6.45 |
| | | | | 80 | 48.7 | 38.2 | 121.0 | 2.55 | 5.59 | 41.8 | 39.0 | 115.2 | 2.42 | 6.8 | 5.90 |
| | 5.4 | 2.1 | 4.9 | 60 | 55.5 | 45.8 | 106.8 | 2.41 | 6.76 | 48.6 | 46.7 | 100.9 | 2.26 | 6.9 | 7.19 |
| | | | | 70 | 53.5 | 43.2 | 115.1 | 2.54 | 6.19 | 46.4 | 44.1 | 109.1 | 2.39 | 7.1 | 6.57 |
| | | | | 80 | 51.4 | 40.6 | 123.3 | 2.66 | 5.66 | 44.2 | 41.4 | 117.2 | 2.51 | 7.2 | 6.01 |
| | 7.0 | 3.4 | 7.9 | 60 | 57.4 | 47.4 | 108.3 | 2.45 | 6.88 | 50.3 | 48.4 | 102.3 | 2.29 | 7.1 | 7.34 |
| | | | | 70 | 55.2 | 44.7 | 116.5 | 2.57 | 6.29 | 47.9 | 45.7 | 110.3 | 2.42 | 7.3 | 6.69 |
| | | | | 80 | 53.0 | 42.0 | 124.6 | 2.70 | 5.76 | 45.6 | 42.9 | 118.4 | 2.54 | 7.4 | 6.12 |

Notes:

- Capacity data includes water pumping watts and are base upon 15% (by volume) propylene glycol antifreeze solution.
- Desuperheater Capacity is based upon 0.4 GPM Flow per nominal ton at 90°F entering hot water temperature.
- The manufacturer reserves the right to make changes in design and construction at any time without notice.
- Extrapolation data down to 25°F for heating and interpolation between CFM, EWT & GPM data is permissible.
- See Flow Rate Selection on page 7 for proper application.

GT048 Performance Data: 4.0 Ton, 1700 CFM, High Capacity Cooling

| EWT | GPM | WPD | | EAT DB/ WB | Cooling | | | | | Cooling with Desuperheater | | | | | |
|-----|------|-----|------|------------------|---------|------|------|------|------|----------------------------|------|------|------|------|------|
| | | PSI | FT | | TC | SC | HR | KW | EER | TC | SC | HR | KW | DH | EER |
| 50 | 6.7 | 2.1 | 4.8 | 75/63 | 56.5 | 39.5 | 66.5 | 2.96 | 19.1 | 56.5 | 39.5 | 66.5 | 2.91 | 4.5 | 19.4 |
| | | | | 80/67 | 61.3 | 41.1 | 70.8 | 3.03 | 20.2 | 61.3 | 41.2 | 70.7 | 2.96 | 4.6 | 20.7 |
| | | | | 85/71 | 66.2 | 42.7 | 75.0 | 3.09 | 21.4 | 66.2 | 42.8 | 75.0 | 3.03 | 4.7 | 21.9 |
| | 9.3 | 3.7 | 8.6 | 75/63 | 57.0 | 39.8 | 66.7 | 2.83 | 20.2 | 57.0 | 39.9 | 66.7 | 2.79 | 4.5 | 20.4 |
| | | | | 80/67 | 61.9 | 41.4 | 70.9 | 2.89 | 21.4 | 61.9 | 41.5 | 71.0 | 2.85 | 4.6 | 21.7 |
| | | | | 85/71 | 66.9 | 43.1 | 75.2 | 2.95 | 22.7 | 66.9 | 43.1 | 75.2 | 2.91 | 4.8 | 23.0 |
| | 12.0 | 6.0 | 14.0 | 75/63 | 57.6 | 39.8 | 67.1 | 2.75 | 21.0 | 57.6 | 39.9 | 67.1 | 2.74 | 4.3 | 21.1 |
| | | | | 80/67 | 62.6 | 41.4 | 71.4 | 2.80 | 22.3 | 62.6 | 41.5 | 71.4 | 2.79 | 4.4 | 22.4 |
| | | | | 85/71 | 67.6 | 43.1 | 75.6 | 2.86 | 23.6 | 67.6 | 43.1 | 75.7 | 2.84 | 4.5 | 23.8 |
| 70 | 6.7 | 2.0 | 4.7 | 75/63 | 53.0 | 38.3 | 64.7 | 3.56 | 14.9 | 53.3 | 38.8 | 64.8 | 3.48 | 6.8 | 15.3 |
| | | | | 80/67 | 57.5 | 40.3 | 68.8 | 3.65 | 15.8 | 57.8 | 40.5 | 68.9 | 3.54 | 7.1 | 16.3 |
| | | | | 85/71 | 62.2 | 41.9 | 73.0 | 3.70 | 16.8 | 62.5 | 42.1 | 73.1 | 3.63 | 7.3 | 17.2 |
| | 9.3 | 3.6 | 8.3 | 75/63 | 53.8 | 39.1 | 65.0 | 3.39 | 15.9 | 54.1 | 39.3 | 65.2 | 3.33 | 6.6 | 16.2 |
| | | | | 80/67 | 58.4 | 40.7 | 69.1 | 3.46 | 16.9 | 58.8 | 40.9 | 69.4 | 3.41 | 6.8 | 17.2 |
| | | | | 85/71 | 63.1 | 42.4 | 73.3 | 3.53 | 17.9 | 63.5 | 42.6 | 73.6 | 3.46 | 7.0 | 18.3 |
| | 12.0 | 5.8 | 13.3 | 75/63 | 54.2 | 39.1 | 65.3 | 3.29 | 16.5 | 54.6 | 39.3 | 65.5 | 3.27 | 6.3 | 16.7 |
| | | | | 80/67 | 59.0 | 40.7 | 69.5 | 3.35 | 17.6 | 59.4 | 40.9 | 69.7 | 3.34 | 6.5 | 17.8 |
| | | | | 85/71 | 63.7 | 42.4 | 73.6 | 3.42 | 18.6 | 64.0 | 42.6 | 73.9 | 3.39 | 6.7 | 18.9 |
| 90 | 6.7 | 1.9 | 4.3 | 75/63 | 48.2 | 37.1 | 62.3 | 4.40 | 10.9 | 48.7 | 37.4 | 62.5 | 4.27 | 9.0 | 11.4 |
| | | | | 80/67 | 52.4 | 38.6 | 66.2 | 4.49 | 11.7 | 52.9 | 39.0 | 66.5 | 4.36 | 9.3 | 12.1 |
| | | | | 85/71 | 56.6 | 40.3 | 70.3 | 4.56 | 12.4 | 57.1 | 40.5 | 70.6 | 4.44 | 9.5 | 12.9 |
| | 9.3 | 3.3 | 7.7 | 75/63 | 49.1 | 37.5 | 62.6 | 4.14 | 11.9 | 49.6 | 37.8 | 63.0 | 4.06 | 8.7 | 12.2 |
| | | | | 80/67 | 53.4 | 39.1 | 66.6 | 4.25 | 12.6 | 53.9 | 39.3 | 66.9 | 4.14 | 8.9 | 13.0 |
| | | | | 85/71 | 57.7 | 40.6 | 70.5 | 4.31 | 13.4 | 58.3 | 40.9 | 71.0 | 4.23 | 9.2 | 13.8 |
| | 12.0 | 5.4 | 12.4 | 75/63 | 49.7 | 37.5 | 62.7 | 4.04 | 12.3 | 50.2 | 37.8 | 63.2 | 3.99 | 8.3 | 12.6 |
| | | | | 80/67 | 54.0 | 39.1 | 66.7 | 4.11 | 13.1 | 54.5 | 39.3 | 67.3 | 4.07 | 8.6 | 13.4 |
| | | | | 85/71 | 58.3 | 40.6 | 70.8 | 4.21 | 13.9 | 58.9 | 40.9 | 71.4 | 4.14 | 8.8 | 14.2 |
| 110 | 6.7 | 1.8 | 4.2 | 75/63 | 42.0 | 34.8 | 59.3 | 5.49 | 7.7 | 42.7 | 35.1 | 59.5 | 5.33 | 11.1 | 8.0 |
| | | | | 80/67 | 45.6 | 36.2 | 63.1 | 5.56 | 8.2 | 46.4 | 36.5 | 63.3 | 5.41 | 11.5 | 8.6 |
| | | | | 85/71 | 49.4 | 37.6 | 66.8 | 5.70 | 8.7 | 50.2 | 38.0 | 67.1 | 5.50 | 11.8 | 9.1 |
| | 9.3 | 3.3 | 7.7 | 75/63 | 43.1 | 35.2 | 59.5 | 5.13 | 8.4 | 43.8 | 35.5 | 59.8 | 5.06 | 10.8 | 8.7 |
| | | | | 80/67 | 46.9 | 36.6 | 63.2 | 5.25 | 8.9 | 47.7 | 36.9 | 63.7 | 5.13 | 11.1 | 9.3 |
| | | | | 85/71 | 50.6 | 38.1 | 67.1 | 5.39 | 9.4 | 41.5 | 38.4 | 67.5 | 5.23 | 11.4 | 9.8 |
| | 12.0 | 5.3 | 12.1 | 75/63 | 43.5 | 35.2 | 59.5 | 5.03 | 8.7 | 44.3 | 35.5 | 60.1 | 4.95 | 10.3 | 8.9 |
| | | | | 80/67 | 47.4 | 36.6 | 63.2 | 5.09 | 9.3 | 48.2 | 36.9 | 63.9 | 5.08 | 10.7 | 9.5 |
| | | | | 85/71 | 51.1 | 38.1 | 67.1 | 5.19 | 9.8 | 52.0 | 38.4 | 67.8 | 5.13 | 11.0 | 10.1 |

Notes:

1. Capacity data includes water pumping watts and are base upon 15% (by volume) propylene glycol antifreeze solution.
2. Desuperheater Capacity is based upon 0.4 GPM Flow per nominal ton at 90°F entering hot water temperature.
3. The manufacturer reserves the right to make changes in design and construction at any time without notice.
4. Extrapolation data down to 25°F for heating and interpolation between CFM, EWT & GPM data is permissible.
5. See Flow Rate Selection on page 7 for proper application.

GT048 Performance Data: 4.0 Ton, 1100 CFM, Low Capacity Cooling

| EWT | GPM | WPD | | EAT DB/ WB | Cooling | | | | | Cooling with Desuperheater | | | | | |
|-----|-----|-----|-----|------------------|---------|------|------|------|------|----------------------------|------|------|------|-----|------|
| | | PSI | FT | | TC | SC | HR | KW | EER | TC | SC | HR | KW | DH | EER |
| 50 | 3.9 | 1.3 | 3.1 | 75/63 | 37.5 | 26.2 | 44.1 | 1.45 | 25.8 | 37.5 | 26.2 | 44.1 | 1.43 | 3.2 | 26.3 |
| | | | | 80/67 | 40.7 | 27.3 | 47.0 | 1.49 | 27.4 | 40.7 | 27.3 | 46.9 | 1.45 | 3.2 | 28.0 |
| | | | | 85/71 | 43.9 | 28.3 | 49.7 | 1.52 | 29.0 | 43.9 | 28.4 | 49.8 | 1.48 | 3.3 | 29.6 |
| | 5.4 | 2.4 | 5.5 | 75/63 | 37.8 | 26.4 | 44.3 | 1.39 | 27.3 | 37.8 | 26.5 | 44.3 | 1.37 | 3.0 | 27.6 |
| | | | | 80/67 | 41.1 | 27.5 | 47.0 | 1.42 | 29.0 | 41.1 | 27.5 | 47.1 | 1.40 | 3.1 | 29.4 |
| | | | | 85/71 | 44.4 | 28.6 | 49.9 | 1.45 | 30.7 | 44.4 | 28.6 | 49.9 | 1.43 | 3.2 | 31.1 |
| | 7.0 | 3.9 | 8.9 | 75/63 | 38.2 | 26.4 | 44.5 | 1.35 | 28.4 | 38.2 | 26.5 | 44.5 | 1.34 | 2.8 | 28.5 |
| | | | | 80/67 | 41.6 | 27.5 | 47.3 | 1.38 | 30.2 | 41.6 | 27.5 | 47.4 | 1.37 | 2.9 | 30.3 |
| | | | | 85/71 | 44.9 | 28.6 | 50.1 | 1.40 | 31.9 | 44.9 | 28.6 | 50.2 | 1.39 | 3.0 | 32.2 |
| 70 | 3.9 | 1.3 | 3.0 | 75/63 | 35.1 | 25.7 | 42.9 | 1.75 | 20.1 | 35.3 | 25.8 | 43.0 | 1.71 | 4.5 | 20.7 |
| | | | | 80/67 | 38.2 | 26.7 | 45.6 | 1.79 | 21.3 | 38.4 | 26.8 | 45.7 | 1.74 | 4.7 | 22.1 |
| | | | | 85/71 | 41.2 | 27.8 | 48.4 | 1.82 | 22.7 | 41.5 | 27.9 | 48.5 | 1.78 | 4.8 | 23.3 |
| | 5.4 | 2.3 | 5.3 | 75/63 | 35.7 | 26.0 | 43.1 | 1.66 | 21.5 | 35.9 | 26.1 | 43.3 | 1.63 | 4.4 | 22.0 |
| | | | | 80/67 | 38.8 | 27.0 | 45.9 | 1.70 | 22.8 | 39.0 | 27.2 | 46.0 | 1.67 | 4.5 | 23.3 |
| | | | | 85/71 | 41.9 | 28.1 | 48.7 | 1.73 | 24.2 | 42.1 | 28.2 | 48.8 | 1.70 | 4.6 | 24.8 |
| | 7.0 | 3.7 | 8.5 | 75/63 | 36.0 | 26.0 | 43.3 | 1.61 | 22.3 | 36.2 | 26.1 | 43.5 | 1.60 | 4.2 | 22.6 |
| | | | | 80/67 | 39.2 | 27.0 | 46.1 | 1.65 | 23.8 | 39.4 | 27.2 | 46.3 | 1.64 | 4.3 | 24.0 |
| | | | | 85/71 | 42.2 | 28.1 | 48.8 | 1.68 | 25.2 | 42.5 | 28.2 | 49.1 | 1.66 | 4.5 | 25.5 |
| 90 | 3.9 | 1.2 | 2.8 | 75/63 | 32.0 | 24.6 | 41.3 | 2.16 | 14.8 | 32.3 | 24.8 | 41.5 | 2.09 | 6.0 | 15.4 |
| | | | | 80/67 | 34.8 | 25.6 | 43.9 | 2.20 | 15.8 | 35.1 | 25.8 | 44.1 | 2.14 | 6.2 | 16.4 |
| | | | | 85/71 | 37.5 | 26.7 | 46.6 | 2.24 | 16.8 | 37.9 | 26.8 | 46.8 | 2.18 | 6.3 | 17.4 |
| | 5.4 | 2.1 | 4.9 | 75/63 | 32.6 | 24.9 | 41.6 | 2.03 | 16.0 | 32.9 | 25.1 | 41.8 | 1.99 | 5.8 | 16.5 |
| | | | | 80/67 | 35.5 | 26.0 | 44.2 | 2.08 | 17.0 | 35.8 | 26.1 | 44.4 | 2.03 | 5.9 | 17.6 |
| | | | | 85/71 | 38.3 | 27.0 | 46.8 | 2.11 | 17.1 | 38.7 | 27.2 | 47.1 | 2.08 | 6.1 | 18.6 |
| | 7.0 | 3.4 | 7.9 | 75/63 | 33.0 | 24.9 | 41.6 | 1.98 | 16.6 | 33.3 | 25.1 | 41.9 | 1.96 | 5.5 | 17.0 |
| | | | | 80/67 | 35.8 | 26.0 | 44.3 | 2.02 | 17.8 | 36.2 | 26.1 | 44.6 | 2.00 | 5.7 | 18.1 |
| | | | | 85/71 | 38.7 | 27.0 | 47.0 | 2.06 | 18.7 | 39.1 | 27.2 | 47.4 | 2.03 | 5.8 | 19.2 |
| 110 | 3.9 | 1.2 | 2.7 | 75/63 | 27.9 | 23.1 | 39.3 | 2.69 | 10.4 | 28.4 | 23.3 | 39.5 | 2.61 | 7.4 | 10.9 |
| | | | | 80/67 | 30.3 | 24.0 | 41.9 | 2.73 | 11.1 | 30.8 | 24.2 | 42.0 | 2.66 | 7.6 | 11.6 |
| | | | | 85/71 | 32.7 | 24.9 | 44.3 | 2.80 | 11.7 | 33.3 | 25.2 | 44.5 | 2.70 | 7.8 | 12.3 |
| | 5.4 | 2.1 | 4.9 | 75/63 | 28.6 | 23.3 | 39.5 | 2.52 | 11.3 | 29.1 | 23.5 | 39.7 | 2.48 | 7.2 | 11.7 |
| | | | | 80/67 | 31.3 | 24.3 | 41.9 | 2.58 | 12.1 | 31.7 | 24.4 | 42.2 | 2.52 | 7.4 | 12.6 |
| | | | | 85/71 | 33.6 | 25.3 | 44.5 | 2.65 | 12.7 | 34.2 | 25.5 | 44.8 | 2.57 | 7.5 | 13.3 |
| | 7.0 | 3.4 | 7.8 | 75/63 | 28.9 | 23.3 | 39.5 | 2.47 | 11.7 | 29.4 | 23.5 | 39.8 | 2.43 | 6.8 | 12.1 |
| | | | | 80/67 | 31.4 | 24.3 | 41.9 | 2.50 | 12.6 | 32.0 | 24.4 | 42.4 | 2.49 | 7.1 | 12.8 |
| | | | | 85/71 | 33.9 | 25.3 | 44.5 | 2.55 | 13.3 | 34.5 | 25.5 | 45.0 | 2.52 | 7.3 | 13.7 |

Notes:

- Capacity data includes water pumping watts and are base upon 15% (by volume) propylene glycol antifreeze solution.
- Desuperheater Capacity is based upon 0.4 GPM Flow per nominal ton at 90°F entering hot water temperature.
- The manufacturer reserves the right to make changes in design and construction at any time without notice.
- Extrapolation data down to 25°F for heating and interpolation between CFM, EWT & GPM data is permissible.
- See Flow Rate Selection on page 7 for proper application.

GT060 Performance Data: 5.0 Ton, 2100 CFM, High Capacity Heating

| EWT | GPM | WPD | | Heating | | | | | | Heating with Desuperheater | | | | | |
|-----|------|-----|------|---------|------|------|-------|------|------|----------------------------|------|-------|------|------|------|
| | | PSI | FT | EAT | HC | HE | LAT | KW | COP | HC | HE | LAT | KW | DH | COP |
| 30 | 8.3 | 2.2 | 5.1 | 60 | 49.9 | 35.8 | 82.0 | 4.21 | 3.48 | 43.7 | 35.9 | 79.3 | 4.16 | 6.2 | 3.52 |
| | | | | 70 | 48.5 | 33.7 | 91.4 | 4.43 | 3.21 | 42.1 | 33.9 | 88.6 | 4.35 | 6.4 | 3.27 |
| | | | | 80 | 47.0 | 31.8 | 100.7 | 4.65 | 2.97 | 40.4 | 31.8 | 97.8 | 4.55 | 6.6 | 3.03 |
| | 11.7 | 4.1 | 9.6 | 60 | 51.5 | 37.4 | 82.7 | 4.25 | 3.55 | 45.1 | 37.5 | 79.9 | 4.16 | 6.4 | 3.63 |
| | | | | 70 | 50.0 | 35.1 | 92.1 | 4.48 | 3.28 | 43.4 | 35.4 | 89.1 | 4.38 | 6.6 | 3.35 |
| | | | | 80 | 48.7 | 33.0 | 101.5 | 4.70 | 3.03 | 41.8 | 33.2 | 98.4 | 4.60 | 6.8 | 3.10 |
| | 15.0 | 6.7 | 15.4 | 60 | 52.1 | 38.1 | 83.0 | 4.25 | 3.60 | 45.6 | 38.3 | 80.1 | 4.16 | 6.5 | 3.68 |
| | | | | 70 | 50.8 | 36.0 | 92.4 | 4.47 | 3.33 | 44.0 | 30.9 | 89.4 | 4.38 | 6.7 | 3.39 |
| | | | | 80 | 49.4 | 33.7 | 101.8 | 4.70 | 3.08 | 42.4 | 33.9 | 98.7 | 4.61 | 6.9 | 3.14 |
| 50 | 8.3 | 2.1 | 4.8 | 60 | 64.6 | 50.1 | 88.5 | 4.41 | 4.30 | 56.6 | 50.5 | 84.9 | 4.26 | 8.0 | 4.45 |
| | | | | 70 | 62.7 | 47.1 | 97.6 | 4.64 | 3.96 | 54.4 | 47.6 | 94.0 | 4.50 | 8.3 | 4.09 |
| | | | | 80 | 60.5 | 44.3 | 106.7 | 4.87 | 3.65 | 52.0 | 44.8 | 102.9 | 4.73 | 8.5 | 3.75 |
| | 11.7 | 3.8 | 8.9 | 60 | 67.3 | 52.4 | 89.7 | 4.49 | 4.39 | 59.0 | 53.0 | 86.0 | 4.35 | 8.4 | 4.54 |
| | | | | 70 | 65.1 | 49.5 | 98.7 | 4.73 | 4.03 | 56.5 | 49.9 | 94.9 | 4.57 | 8.6 | 4.17 |
| | | | | 80 | 63.0 | 46.4 | 107.8 | 4.97 | 3.71 | 54.2 | 47.0 | 103.9 | 4.81 | 8.8 | 3.84 |
| | 15.0 | 6.2 | 14.4 | 60 | 68.7 | 53.8 | 90.3 | 4.51 | 4.46 | 60.2 | 54.3 | 86.5 | 4.35 | 8.6 | 4.63 |
| | | | | 70 | 66.5 | 50.8 | 99.3 | 4.75 | 4.10 | 57.7 | 51.3 | 95.4 | 4.60 | 8.8 | 4.24 |
| | | | | 80 | 64.3 | 47.7 | 108.3 | 4.99 | 3.77 | 55.2 | 48.3 | 104.4 | 4.83 | 9.0 | 3.90 |
| 70 | 8.3 | 2.1 | 4.8 | 60 | 78.6 | 63.2 | 94.7 | 4.68 | 4.92 | 68.8 | 64.0 | 90.3 | 4.47 | 9.8 | 5.16 |
| | | | | 70 | 75.8 | 59.5 | 103.4 | 4.93 | 4.51 | 65.8 | 60.3 | 99.0 | 4.71 | 10.0 | 4.72 |
| | | | | 80 | 73.0 | 55.9 | 112.2 | 5.17 | 4.14 | 62.8 | 56.8 | 107.7 | 4.95 | 10.3 | 4.33 |
| | 11.7 | 3.7 | 8.5 | 60 | 82.6 | 66.5 | 96.4 | 4.82 | 5.02 | 72.3 | 67.6 | 91.9 | 4.60 | 10.3 | 5.26 |
| | | | | 70 | 79.6 | 62.8 | 105.1 | 5.07 | 4.60 | 69.1 | 63.7 | 100.5 | 4.85 | 10.5 | 4.81 |
| | | | | 80 | 76.7 | 58.9 | 113.8 | 5.34 | 4.21 | 65.9 | 59.9 | 109.1 | 5.09 | 10.8 | 4.42 |
| | 15.0 | 5.9 | 13.7 | 60 | 84.8 | 68.6 | 97.4 | 4.88 | 5.09 | 74.2 | 69.7 | 92.7 | 4.64 | 10.6 | 5.36 |
| | | | | 70 | 81.7 | 64.7 | 106.0 | 5.13 | 4.67 | 70.9 | 65.8 | 101.3 | 4.89 | 10.8 | 4.90 |
| | | | | 80 | 78.6 | 60.8 | 114.7 | 5.39 | 4.28 | 67.6 | 61.9 | 109.8 | 5.13 | 11.0 | 4.49 |
| 90 | 8.3 | 1.9 | 4.4 | 60 | 90.6 | 74.5 | 100.0 | 4.65 | 5.72 | 79.4 | 75.9 | 95.0 | 4.62 | 11.3 | 5.75 |
| | | | | 70 | 87.3 | 70.1 | 108.5 | 5.26 | 4.87 | 75.8 | 71.5 | 103.4 | 4.87 | 11.5 | 5.25 |
| | | | | 80 | 83.9 | 66.0 | 117.0 | 5.41 | 4.55 | 72.2 | 67.2 | 111.8 | 5.12 | 11.8 | 4.80 |
| | 11.7 | 3.4 | 7.9 | 60 | 95.8 | 78.9 | 102.2 | 5.10 | 5.50 | 83.9 | 80.5 | 97.0 | 4.80 | 11.9 | 5.86 |
| | | | | 70 | 92.3 | 74.5 | 110.7 | 5.37 | 5.04 | 80.1 | 76.0 | 105.3 | 5.06 | 12.2 | 5.35 |
| | | | | 80 | 88.7 | 70.0 | 119.1 | 5.64 | 4.61 | 76.2 | 71.4 | 113.6 | 5.31 | 12.5 | 4.89 |
| | 15.0 | 5.5 | 12.6 | 60 | 99.0 | 81.7 | 103.7 | 5.18 | 5.60 | 86.7 | 83.5 | 98.2 | 4.86 | 12.3 | 5.97 |
| | | | | 70 | 95.2 | 77.1 | 112.0 | 5.45 | 5.12 | 82.7 | 78.8 | 106.4 | 5.12 | 12.6 | 5.45 |
| | | | | 80 | 91.5 | 72.5 | 120.3 | 5.72 | 4.69 | 78.6 | 74.1 | 114.7 | 5.38 | 12.8 | 4.98 |

Notes:

1. Capacity data includes water pumping watts and are base upon 15% (by volume) propylene glycol antifreeze solution.
2. Desuperheater Capacity is based upon 0.4 GPM Flow per nominal ton at 90°F entering hot water temperature.
3. The manufacturer reserves the right to make changes in design and construction at any time without notice.
4. Extrapolation data down to 25°F for heating and interpolation between CFM, EWT & GPM data is permissible.
5. See Flow Rate Selection on page 7 for proper application.

GT060 Performance Data: 5.0 Ton, 1300 CFM, Low Capacity Heating

| EWT | GPM | WPD | | Heating | | | | | | Heating with Desuperheater | | | | | |
|-----|------|-----|------|---------|------|------|-------|------|------|----------------------------|------|-------|------|-----|------|
| | | PSI | FT | EAT | HC | HE | LAT | KW | COP | HC | HE | LAT | KW | DH | COP |
| 30 | 5.6 | 1.4 | 3.3 | 60 | 34.9 | 25.1 | 84.9 | 2.39 | 4.28 | 30.6 | 25.1 | 81.8 | 2.37 | 4.3 | 4.33 |
| | | | | 70 | 33.9 | 23.6 | 94.2 | 2.52 | 3.94 | 29.4 | 23.7 | 91.0 | 2.48 | 4.5 | 4.02 |
| | | | | 80 | 32.9 | 22.2 | 103.4 | 2.64 | 3.64 | 28.2 | 22.3 | 100.1 | 2.59 | 4.6 | 3.72 |
| | 7.8 | 2.7 | 6.2 | 60 | 36.0 | 26.1 | 85.6 | 2.42 | 4.36 | 31.5 | 26.2 | 82.4 | 2.37 | 4.5 | 4.46 |
| | | | | 70 | 35.0 | 24.6 | 94.9 | 2.55 | 4.03 | 30.4 | 24.7 | 91.6 | 2.49 | 4.6 | 4.11 |
| | | | | 80 | 34.0 | 23.1 | 104.2 | 2.68 | 3.73 | 29.3 | 23.2 | 100.8 | 2.62 | 4.8 | 3.81 |
| | 10.0 | 4.3 | 10.0 | 60 | 36.4 | 26.6 | 86.0 | 2.42 | 4.42 | 31.9 | 26.8 | 82.7 | 2.36 | 4.5 | 4.52 |
| | | | | 70 | 35.5 | 25.2 | 95.3 | 2.55 | 4.09 | 30.8 | 21.6 | 91.9 | 2.49 | 4.7 | 4.17 |
| | | | | 80 | 34.5 | 23.6 | 104.6 | 2.67 | 3.79 | 29.7 | 23.7 | 101.1 | 2.62 | 4.8 | 3.86 |
| 50 | 5.6 | 1.3 | 3.1 | 60 | 45.2 | 35.0 | 92.2 | 2.51 | 5.28 | 39.5 | 35.3 | 88.2 | 2.42 | 5.6 | 5.46 |
| | | | | 70 | 43.8 | 33.0 | 101.2 | 2.64 | 4.86 | 38.0 | 33.2 | 97.1 | 2.56 | 5.8 | 5.02 |
| | | | | 80 | 42.3 | 31.0 | 110.2 | 2.77 | 4.48 | 36.4 | 31.3 | 105.9 | 2.69 | 5.9 | 4.61 |
| | 7.8 | 2.5 | 5.8 | 60 | 47.1 | 36.7 | 93.5 | 2.56 | 5.40 | 41.2 | 37.1 | 89.4 | 2.47 | 5.9 | 5.58 |
| | | | | 70 | 45.5 | 34.6 | 102.4 | 2.69 | 4.96 | 39.5 | 34.9 | 98.1 | 2.60 | 6.0 | 5.13 |
| | | | | 80 | 44.1 | 32.5 | 111.4 | 2.83 | 4.56 | 37.9 | 32.9 | 107.0 | 2.74 | 6.2 | 4.72 |
| | 10.0 | 4.0 | 9.3 | 60 | 48.0 | 37.6 | 94.2 | 2.57 | 5.48 | 42.1 | 38.0 | 90.0 | 2.48 | 6.0 | 5.69 |
| | | | | 70 | 46.5 | 35.5 | 103.1 | 2.70 | 5.04 | 40.4 | 35.9 | 98.7 | 2.62 | 6.1 | 5.21 |
| | | | | 80 | 44.9 | 33.3 | 112.0 | 2.84 | 4.63 | 38.6 | 33.7 | 107.5 | 2.75 | 6.3 | 4.79 |
| 70 | 5.6 | 1.3 | 3.1 | 60 | 55.0 | 44.2 | 99.1 | 2.67 | 6.04 | 48.1 | 44.7 | 94.3 | 2.54 | 6.8 | 6.33 |
| | | | | 70 | 53.0 | 41.6 | 107.8 | 2.80 | 5.54 | 46.0 | 42.2 | 102.8 | 2.68 | 7.0 | 5.80 |
| | | | | 80 | 51.1 | 39.1 | 116.4 | 2.94 | 5.09 | 43.9 | 39.7 | 111.3 | 2.81 | 7.2 | 5.32 |
| | 7.8 | 2.4 | 5.5 | 60 | 57.7 | 46.5 | 101.1 | 2.74 | 6.16 | 50.5 | 47.3 | 96.0 | 2.62 | 7.2 | 6.46 |
| | | | | 70 | 55.7 | 43.9 | 109.7 | 2.89 | 5.65 | 48.3 | 44.5 | 104.4 | 2.76 | 7.4 | 5.92 |
| | | | | 80 | 53.6 | 41.2 | 118.2 | 3.04 | 5.17 | 46.1 | 41.9 | 112.8 | 2.90 | 7.5 | 5.43 |
| | 10.0 | 3.8 | 8.9 | 60 | 59.3 | 48.0 | 102.2 | 2.78 | 6.26 | 51.9 | 48.7 | 97.0 | 2.64 | 7.4 | 6.58 |
| | | | | 70 | 57.1 | 45.2 | 110.7 | 2.92 | 5.73 | 49.6 | 46.0 | 105.3 | 2.78 | 7.6 | 6.02 |
| | | | | 80 | 55.0 | 42.5 | 119.2 | 3.07 | 5.26 | 47.3 | 43.3 | 113.7 | 2.92 | 7.7 | 5.52 |
| 90 | 5.6 | 1.2 | 2.9 | 60 | 63.4 | 52.1 | 105.1 | 2.64 | 7.02 | 55.5 | 53.1 | 99.5 | 2.63 | 7.9 | 7.06 |
| | | | | 70 | 61.0 | 49.0 | 113.5 | 2.99 | 5.98 | 53.0 | 50.0 | 107.7 | 2.77 | 8.1 | 6.45 |
| | | | | 80 | 58.7 | 46.1 | 121.8 | 3.08 | 5.59 | 50.5 | 47.0 | 115.9 | 2.91 | 8.2 | 5.90 |
| | 7.8 | 2.2 | 5.1 | 60 | 67.0 | 55.2 | 107.7 | 2.90 | 6.76 | 58.6 | 56.3 | 101.8 | 2.73 | 8.3 | 7.19 |
| | | | | 70 | 64.5 | 52.1 | 116.0 | 3.06 | 6.19 | 56.0 | 53.2 | 109.9 | 2.88 | 8.5 | 6.57 |
| | | | | 80 | 62.0 | 48.9 | 124.2 | 3.21 | 5.66 | 53.3 | 49.9 | 118.0 | 3.02 | 8.7 | 6.01 |
| | 10.0 | 3.6 | 8.2 | 60 | 69.2 | 57.1 | 109.3 | 2.95 | 6.88 | 60.6 | 58.4 | 103.2 | 2.76 | 8.6 | 7.34 |
| | | | | 70 | 66.6 | 53.9 | 117.4 | 3.10 | 6.29 | 57.8 | 55.1 | 111.2 | 2.92 | 8.8 | 6.69 |
| | | | | 80 | 64.0 | 50.7 | 125.6 | 3.26 | 5.76 | 55.0 | 51.8 | 119.2 | 3.06 | 9.0 | 6.12 |

Notes:

- Capacity data includes water pumping watts and are base upon 15% (by volume) propylene glycol antifreeze solution.
- Desuperheater Capacity is based upon 0.4 GPM Flow per nominal ton at 90°F entering hot water temperature.
- The manufacturer reserves the right to make changes in design and construction at any time without notice.
- Extrapolation data down to 25°F for heating and interpolation between CFM, EWT & GPM data is permissible.
- See Flow Rate Selection on page 7 for proper application.

GT060 Performance Data: 5.0 Ton, 2100 CFM, High Capacity Cooling

| EWT | GPM | WPD | | EAT DB/ WB | Cooling | | | | | Cooling with Desuperheater | | | | | |
|-----|------|-----|------|------------------|---------|------|------|------|------|----------------------------|------|------|------|------|------|
| | | PSI | FT | | TC | SC | HR | KW | EER | TC | SC | HR | KW | DH | EER |
| 50 | 8.3 | 2.1 | 5.0 | 75/63 | 64.6 | 45.2 | 76.1 | 3.43 | 18.8 | 64.6 | 45.2 | 76.1 | 3.36 | 5.4 | 19.2 |
| | | | | 80/67 | 70.2 | 47.0 | 81.0 | 3.51 | 20.2 | 70.2 | 47.1 | 80.9 | 3.43 | 5.6 | 20.5 |
| | | | | 85/71 | 75.8 | 48.9 | 85.8 | 3.58 | 21.2 | 75.8 | 49.0 | 85.8 | 3.50 | 5.7 | 21.6 |
| | 11.7 | 3.8 | 8.9 | 75/63 | 65.3 | 45.6 | 76.3 | 3.28 | 19.9 | 65.3 | 45.6 | 76.3 | 3.23 | 5.2 | 20.2 |
| | | | | 80/67 | 70.9 | 47.4 | 81.1 | 3.34 | 21.2 | 70.9 | 47.5 | 81.3 | 3.30 | 5.3 | 21.5 |
| | | | | 85/71 | 76.6 | 49.3 | 86.0 | 3.41 | 22.4 | 76.6 | 49.4 | 86.1 | 3.37 | 5.4 | 22.7 |
| | 15.0 | 6.2 | 14.4 | 75/63 | 65.9 | 45.6 | 76.7 | 3.18 | 20.7 | 65.9 | 45.6 | 76.7 | 3.17 | 4.9 | 20.8 |
| | | | | 80/67 | 71.7 | 47.4 | 81.7 | 3.24 | 22.1 | 71.7 | 47.5 | 81.7 | 3.23 | 5.0 | 22.2 |
| | | | | 85/71 | 77.4 | 49.3 | 86.4 | 3.31 | 23.4 | 77.4 | 49.4 | 86.6 | 3.29 | 5.2 | 23.5 |
| 70 | 8.3 | 2.1 | 4.8 | 75/63 | 60.6 | 44.4 | 74.1 | 4.12 | 14.7 | 61.0 | 44.4 | 74.2 | 4.02 | 7.8 | 15.1 |
| | | | | 80/67 | 65.8 | 46.1 | 78.7 | 4.22 | 15.6 | 66.2 | 46.3 | 78.9 | 4.10 | 8.1 | 16.1 |
| | | | | 85/71 | 71.1 | 48.0 | 83.5 | 4.29 | 16.6 | 71.5 | 48.2 | 83.7 | 4.20 | 8.4 | 17.0 |
| | 11.7 | 3.7 | 8.5 | 75/63 | 61.5 | 44.8 | 74.3 | 3.92 | 15.7 | 61.9 | 45.0 | 74.6 | 3.86 | 7.6 | 16.0 |
| | | | | 80/67 | 66.9 | 46.6 | 79.1 | 4.01 | 16.7 | 67.3 | 46.8 | 79.4 | 3.95 | 7.8 | 17.0 |
| | | | | 85/71 | 72.2 | 48.5 | 83.9 | 4.09 | 17.7 | 72.6 | 48.7 | 84.2 | 4.01 | 8.0 | 18.1 |
| | 15.0 | 5.9 | 13.7 | 75/63 | 62.1 | 44.8 | 74.7 | 3.80 | 16.3 | 62.4 | 45.0 | 75.0 | 3.78 | 7.2 | 16.5 |
| | | | | 80/67 | 67.5 | 46.6 | 79.5 | 3.88 | 17.4 | 67.9 | 46.8 | 79.8 | 3.86 | 7.4 | 17.6 |
| | | | | 85/71 | 72.9 | 48.5 | 84.2 | 3.96 | 18.4 | 73.3 | 48.7 | 84.6 | 3.93 | 7.7 | 18.7 |
| 90 | 8.3 | 1.9 | 4.4 | 75/63 | 55.1 | 42.5 | 71.3 | 5.10 | 10.8 | 55.7 | 42.8 | 71.5 | 4.94 | 10.3 | 11.3 |
| | | | | 80/67 | 59.9 | 44.2 | 75.8 | 5.19 | 11.5 | 60.5 | 44.6 | 76.1 | 5.05 | 10.6 | 12.0 |
| | | | | 85/71 | 64.7 | 46.1 | 80.5 | 5.28 | 12.3 | 65.4 | 46.3 | 80.7 | 5.14 | 10.9 | 12.7 |
| | 11.7 | 3.4 | 7.9 | 75/63 | 56.2 | 42.9 | 71.7 | 4.80 | 11.7 | 56.8 | 43.2 | 72.1 | 4.70 | 10.0 | 12.1 |
| | | | | 80/67 | 61.1 | 44.8 | 76.2 | 4.91 | 12.4 | 61.7 | 45.0 | 76.6 | 4.79 | 10.2 | 12.9 |
| | | | | 85/71 | 66.1 | 46.5 | 80.7 | 4.99 | 13.3 | 66.7 | 46.8 | 81.3 | 4.90 | 10.5 | 13.6 |
| | 15.0 | 5.5 | 12.7 | 75/63 | 56.9 | 42.9 | 71.8 | 4.67 | 12.2 | 57.4 | 43.2 | 72.3 | 4.62 | 9.6 | 12.4 |
| | | | | 80/67 | 61.8 | 44.8 | 76.3 | 4.76 | 13.0 | 62.4 | 45.0 | 77.0 | 4.71 | 9.8 | 13.3 |
| | | | | 85/71 | 66.7 | 46.5 | 81.0 | 4.87 | 13.7 | 67.4 | 46.8 | 81.7 | 4.79 | 10.1 | 14.1 |
| 110 | 8.3 | 1.9 | 4.3 | 75/63 | 48.1 | 39.8 | 67.8 | 6.35 | 7.6 | 48.9 | 40.2 | 68.1 | 6.16 | 12.7 | 7.9 |
| | | | | 80/67 | 52.2 | 41.4 | 72.2 | 6.44 | 8.1 | 53.1 | 41.8 | 72.5 | 6.27 | 13.1 | 8.5 |
| | | | | 85/71 | 56.5 | 43.0 | 76.5 | 6.59 | 8.6 | 57.4 | 43.5 | 76.7 | 6.37 | 13.5 | 9.0 |
| | 11.7 | 3.4 | 7.9 | 75/63 | 49.3 | 40.2 | 68.1 | 5.94 | 8.3 | 50.1 | 40.6 | 68.5 | 5.85 | 12.3 | 8.6 |
| | | | | 80/67 | 53.7 | 41.8 | 72.3 | 6.08 | 8.8 | 54.6 | 42.2 | 72.9 | 5.94 | 12.7 | 9.2 |
| | | | | 85/71 | 57.9 | 43.6 | 76.7 | 6.24 | 9.3 | 58.9 | 43.9 | 77.3 | 6.05 | 13.0 | 9.7 |
| | 15.0 | 5.4 | 12.5 | 75/63 | 49.8 | 40.2 | 68.1 | 5.82 | 8.6 | 50.7 | 40.6 | 68.7 | 5.73 | 11.8 | 8.8 |
| | | | | 80/67 | 54.2 | 41.8 | 72.3 | 5.90 | 9.2 | 55.1 | 42.2 | 73.1 | 5.88 | 12.2 | 9.4 |
| | | | | 85/71 | 58.5 | 43.6 | 76.7 | 6.01 | 9.7 | 59.5 | 43.9 | 77.5 | 5.94 | 12.6 | 10.0 |

Notes:

1. Capacity data includes water pumping watts and are base upon 15% (by volume) propylene glycol antifreeze solution.
2. Desuperheater Capacity is based upon 0.4 GPM Flow per nominal ton at 90°F entering hot water temperature.
3. The manufacturer reserves the right to make changes in design and construction at any time without notice.
4. Extrapolation data down to 25°F for heating and interpolation between CFM, EWT & GPM data is permissible.
5. See Flow Rate Selection on page 7 for proper application.

GT060 Performance Data: 5.0 Ton, 1300 CFM, Low Capacity Cooling

| EWT | GPM | WPD | | EAT DB/ WB | Cooling | | | | | Cooling with Desuperheater | | | | | |
|-----|------|-----|-----|------------------|---------|------|------|------|------|----------------------------|------|------|------|-----|------|
| | | PSI | FT | | TC | SC | HR | KW | EER | TC | SC | HR | KW | DH | EER |
| 50 | 5.6 | 1.4 | 3.2 | 75/63 | 45.2 | 31.6 | 53.2 | 1.77 | 25.6 | 45.2 | 31.6 | 53.2 | 1.73 | 3.8 | 26.0 |
| | | | | 80/67 | 49.1 | 32.9 | 56.6 | 1.81 | 27.1 | 49.1 | 32.9 | 56.5 | 1.77 | 3.9 | 27.8 |
| | | | | 85/71 | 53.0 | 34.2 | 60.0 | 1.84 | 28.7 | 53.0 | 34.2 | 60.0 | 1.81 | 4.0 | 29.3 |
| | 7.8 | 2.5 | 5.8 | 75/63 | 45.6 | 31.8 | 53.4 | 1.69 | 27.0 | 45.6 | 31.9 | 53.4 | 1.67 | 3.6 | 27.4 |
| | | | | 80/67 | 49.5 | 33.2 | 56.7 | 1.72 | 28.7 | 49.5 | 33.2 | 56.8 | 1.70 | 3.7 | 29.1 |
| | | | | 85/71 | 53.5 | 34.5 | 60.2 | 1.76 | 30.4 | 53.5 | 34.5 | 60.2 | 1.74 | 3.8 | 30.8 |
| | 10.0 | 4.0 | 9.3 | 75/63 | 46.1 | 31.8 | 53.6 | 1.64 | 28.1 | 46.1 | 31.9 | 53.6 | 1.63 | 3.4 | 28.2 |
| | | | | 80/67 | 50.1 | 33.2 | 57.1 | 1.67 | 30.0 | 50.1 | 33.2 | 57.1 | 1.67 | 3.5 | 30.1 |
| | | | | 85/71 | 54.1 | 34.5 | 60.4 | 1.71 | 31.7 | 54.1 | 34.5 | 60.5 | 1.70 | 3.6 | 31.9 |
| 70 | 5.6 | 1.3 | 3.1 | 75/63 | 42.4 | 31.0 | 51.8 | 2.13 | 19.9 | 42.6 | 31.1 | 51.9 | 2.07 | 5.5 | 20.5 |
| | | | | 80/67 | 46.0 | 32.2 | 55.0 | 2.17 | 21.2 | 46.3 | 32.4 | 55.1 | 2.11 | 5.7 | 21.9 |
| | | | | 85/71 | 49.7 | 33.5 | 58.4 | 2.21 | 22.5 | 50.0 | 33.7 | 58.5 | 2.16 | 5.8 | 23.1 |
| | 7.8 | 2.4 | 5.5 | 75/63 | 43.0 | 31.3 | 52.0 | 2.02 | 21.3 | 43.3 | 31.4 | 52.2 | 1.99 | 5.3 | 21.8 |
| | | | | 80/67 | 46.8 | 32.6 | 55.3 | 2.07 | 22.6 | 47.0 | 32.7 | 55.5 | 2.03 | 5.5 | 23.1 |
| | | | | 85/71 | 50.5 | 33.9 | 58.7 | 2.11 | 24.0 | 50.8 | 34.1 | 58.9 | 2.07 | 5.6 | 24.6 |
| | 10.0 | 3.8 | 8.9 | 75/63 | 43.4 | 31.3 | 52.2 | 1.96 | 22.1 | 43.6 | 31.4 | 52.4 | 1.95 | 5.0 | 22.4 |
| | | | | 80/67 | 47.2 | 32.6 | 55.6 | 2.00 | 23.6 | 47.5 | 32.7 | 55.8 | 1.99 | 5.2 | 23.8 |
| | | | | 85/71 | 50.9 | 33.9 | 58.9 | 2.04 | 24.9 | 51.2 | 34.1 | 59.1 | 2.02 | 5.4 | 25.3 |
| 90 | 5.6 | 1.2 | 2.9 | 75/63 | 38.6 | 29.7 | 49.8 | 2.63 | 14.7 | 38.9 | 29.9 | 50.0 | 2.55 | 7.2 | 15.3 |
| | | | | 80/67 | 41.9 | 30.9 | 53.0 | 2.68 | 15.7 | 42.3 | 31.2 | 53.2 | 2.60 | 7.4 | 16.3 |
| | | | | 85/71 | 45.3 | 32.2 | 56.2 | 2.72 | 16.6 | 45.7 | 32.4 | 56.4 | 2.65 | 7.6 | 17.2 |
| | 7.8 | 2.2 | 5.2 | 75/63 | 39.3 | 30.0 | 50.1 | 2.47 | 15.9 | 39.7 | 30.2 | 50.4 | 2.42 | 7.0 | 16.4 |
| | | | | 80/67 | 42.7 | 31.3 | 53.3 | 2.53 | 16.9 | 43.2 | 31.4 | 53.6 | 2.47 | 7.1 | 17.5 |
| | | | | 85/71 | 46.2 | 32.5 | 56.4 | 2.57 | 18.0 | 46.6 | 32.7 | 56.8 | 2.53 | 7.3 | 18.5 |
| | 10.0 | 3.6 | 8.3 | 75/63 | 39.8 | 30.0 | 50.2 | 2.41 | 16.5 | 40.1 | 30.2 | 50.6 | 2.38 | 6.7 | 16.9 |
| | | | | 80/67 | 43.2 | 31.3 | 53.4 | 2.45 | 17.6 | 43.6 | 31.4 | 53.8 | 2.43 | 6.9 | 18.0 |
| | | | | 85/71 | 46.7 | 32.5 | 56.6 | 2.51 | 18.6 | 47.1 | 32.7 | 57.1 | 2.47 | 7.0 | 19.1 |
| 110 | 5.6 | 1.2 | 2.8 | 75/63 | 33.6 | 27.8 | 47.4 | 3.27 | 10.3 | 34.2 | 28.1 | 47.6 | 3.18 | 8.9 | 10.8 |
| | | | | 80/67 | 36.5 | 29.0 | 50.5 | 3.32 | 11.0 | 37.1 | 29.2 | 50.7 | 3.23 | 9.2 | 11.5 |
| | | | | 85/71 | 39.5 | 30.1 | 53.5 | 3.40 | 11.6 | 40.2 | 30.4 | 53.6 | 3.28 | 9.5 | 12.2 |
| | 7.8 | 2.2 | 5.1 | 75/63 | 34.5 | 28.1 | 47.6 | 3.06 | 11.2 | 35.0 | 28.4 | 47.9 | 3.02 | 8.6 | 11.6 |
| | | | | 80/67 | 37.5 | 29.2 | 50.6 | 3.13 | 12.0 | 38.2 | 29.5 | 50.9 | 3.06 | 8.9 | 12.5 |
| | | | | 85/71 | 40.5 | 30.5 | 53.6 | 3.22 | 12.6 | 41.2 | 30.7 | 54.0 | 3.12 | 9.1 | 13.2 |
| | 10.0 | 3.5 | 8.1 | 75/63 | 34.8 | 28.1 | 47.6 | 3.00 | 11.6 | 35.4 | 28.4 | 48.0 | 2.96 | 8.3 | 12.0 |
| | | | | 80/67 | 37.9 | 29.2 | 50.6 | 3.04 | 12.5 | 38.5 | 29.5 | 51.1 | 3.03 | 8.5 | 12.7 |
| | | | | 85/71 | 40.9 | 30.5 | 53.6 | 3.10 | 13.2 | 41.6 | 30.7 | 54.2 | 3.06 | 8.8 | 13.6 |

Notes:

- Capacity data includes water pumping watts and are base upon 15% (by volume) propylene glycol antifreeze solution.
- Desuperheater Capacity is based upon 0.4 GPM Flow per nominal ton at 90°F entering hot water temperature.
- The manufacturer reserves the right to make changes in design and construction at any time without notice.
- Extrapolation data down to 25°F for heating and interpolation between CFM, EWT & GPM data is permissible.
- See Flow Rate Selection on page 7 for proper application.

GT072 Performance Data: 6.0 Ton, 2350 CFM, High Capacity Heating

| EWT | GPM | WPD | | Heating | | | | | | Heating with Desuperheater | | | | | |
|-----|------|-----|------|---------|-------|------|-------|------|------|----------------------------|------|-------|------|------|------|
| | | PSI | FT | EAT | HC | HE | LAT | KW | COP | HC | HE | LAT | KW | DH | COP |
| 30 | 10.0 | 3.2 | 7.5 | 60 | 57.1 | 41.0 | 82.5 | 4.81 | 3.48 | 50.0 | 41.1 | 79.7 | 4.75 | 7.1 | 3.52 |
| | | | | 70 | 55.5 | 38.6 | 91.9 | 5.07 | 3.21 | 48.1 | 38.8 | 89.0 | 4.97 | 7.3 | 3.27 |
| | | | | 80 | 53.7 | 36.3 | 101.2 | 5.31 | 2.97 | 46.2 | 36.4 | 98.2 | 5.20 | 7.5 | 3.03 |
| | 14.0 | 6.1 | 14.0 | 60 | 58.8 | 42.7 | 83.2 | 4.86 | 3.55 | 51.5 | 42.8 | 80.3 | 4.75 | 7.3 | 3.63 |
| | | | | 70 | 57.2 | 40.2 | 92.5 | 5.12 | 3.28 | 49.6 | 40.4 | 89.6 | 5.01 | 7.6 | 3.35 |
| | | | | 80 | 55.6 | 37.8 | 101.9 | 5.38 | 3.03 | 47.8 | 38.0 | 98.8 | 5.26 | 7.8 | 3.10 |
| | 18.0 | 9.7 | 22.5 | 60 | 59.6 | 43.5 | 83.5 | 4.85 | 3.60 | 52.2 | 43.8 | 80.6 | 4.75 | 7.4 | 3.68 |
| | | | | 70 | 58.0 | 41.1 | 92.9 | 5.11 | 3.33 | 50.3 | 35.4 | 89.8 | 5.01 | 7.7 | 3.39 |
| | | | | 80 | 56.4 | 38.6 | 102.2 | 5.37 | 3.08 | 48.5 | 38.8 | 99.1 | 5.27 | 7.9 | 3.14 |
| 50 | 10.0 | 3.0 | 7.0 | 60 | 73.9 | 57.2 | 89.1 | 5.04 | 4.30 | 64.7 | 57.7 | 85.5 | 4.87 | 9.2 | 4.45 |
| | | | | 70 | 71.6 | 53.9 | 98.2 | 5.31 | 3.96 | 62.2 | 54.4 | 94.5 | 5.14 | 9.5 | 4.09 |
| | | | | 80 | 69.2 | 50.7 | 107.3 | 5.56 | 3.65 | 59.5 | 51.2 | 103.4 | 5.40 | 9.7 | 3.75 |
| | 14.0 | 5.6 | 13.0 | 60 | 77.0 | 59.9 | 90.3 | 5.13 | 4.39 | 67.4 | 60.6 | 86.6 | 4.97 | 9.6 | 4.54 |
| | | | | 70 | 74.4 | 56.6 | 99.3 | 5.41 | 4.03 | 64.6 | 57.1 | 95.5 | 5.23 | 9.8 | 4.17 |
| | | | | 80 | 72.1 | 53.1 | 108.4 | 5.69 | 3.71 | 61.9 | 53.7 | 104.4 | 5.50 | 10.1 | 3.84 |
| | 18.0 | 9.1 | 21.0 | 60 | 78.6 | 61.5 | 90.9 | 5.16 | 4.46 | 68.8 | 62.1 | 87.1 | 4.97 | 9.8 | 4.63 |
| | | | | 70 | 76.0 | 58.0 | 100.0 | 5.43 | 4.10 | 66.0 | 58.7 | 96.0 | 5.25 | 10.1 | 4.24 |
| | | | | 80 | 73.4 | 54.5 | 108.9 | 5.71 | 3.77 | 63.1 | 55.2 | 104.9 | 5.52 | 10.3 | 3.90 |
| 70 | 10.0 | 3.0 | 7.0 | 60 | 89.9 | 72.2 | 95.4 | 5.35 | 4.92 | 78.7 | 73.1 | 91.0 | 5.11 | 11.2 | 5.16 |
| | | | | 70 | 86.7 | 68.1 | 104.1 | 5.63 | 4.51 | 75.2 | 69.0 | 99.6 | 5.38 | 11.5 | 4.72 |
| | | | | 80 | 83.5 | 63.9 | 112.9 | 5.91 | 4.14 | 71.8 | 64.9 | 108.3 | 5.65 | 11.7 | 4.33 |
| | 14.0 | 5.4 | 12.5 | 60 | 94.4 | 76.0 | 97.2 | 5.51 | 5.02 | 82.6 | 77.3 | 92.6 | 5.26 | 11.7 | 5.26 |
| | | | | 70 | 91.0 | 71.7 | 105.9 | 5.80 | 4.60 | 79.0 | 72.8 | 101.1 | 5.54 | 12.0 | 4.81 |
| | | | | 80 | 87.7 | 67.4 | 114.5 | 6.10 | 4.21 | 75.4 | 68.5 | 109.7 | 5.82 | 12.3 | 4.42 |
| | 18.0 | 8.6 | 20.0 | 60 | 96.9 | 78.4 | 98.2 | 5.58 | 5.09 | 84.8 | 79.7 | 93.4 | 5.30 | 12.1 | 5.36 |
| | | | | 70 | 93.4 | 74.0 | 106.8 | 5.87 | 4.67 | 81.1 | 75.2 | 101.9 | 5.58 | 12.3 | 4.90 |
| | | | | 80 | 89.9 | 69.5 | 115.4 | 6.16 | 4.28 | 77.3 | 70.7 | 110.4 | 5.86 | 12.6 | 4.49 |
| 90 | 10.0 | 2.8 | 6.5 | 60 | 103.6 | 85.1 | 100.8 | 5.31 | 5.72 | 90.7 | 86.8 | 95.7 | 5.28 | 12.9 | 5.75 |
| | | | | 70 | 99.8 | 80.2 | 109.3 | 6.01 | 4.87 | 86.6 | 81.8 | 104.1 | 5.57 | 13.2 | 5.25 |
| | | | | 80 | 96.0 | 75.4 | 117.8 | 6.18 | 4.55 | 82.5 | 76.8 | 112.5 | 5.85 | 13.5 | 4.80 |
| | 14.0 | 5.0 | 11.5 | 60 | 109.5 | 90.2 | 103.1 | 5.83 | 5.50 | 95.9 | 92.0 | 97.8 | 5.48 | 13.6 | 5.86 |
| | | | | 70 | 105.5 | 85.1 | 111.6 | 6.14 | 5.04 | 91.6 | 86.9 | 106.1 | 5.78 | 13.9 | 5.35 |
| | | | | 80 | 101.4 | 80.0 | 119.9 | 6.45 | 4.61 | 87.1 | 81.6 | 114.3 | 6.07 | 14.2 | 4.89 |
| | 18.0 | 8.0 | 18.5 | 60 | 113.2 | 93.4 | 104.6 | 5.92 | 5.60 | 99.1 | 95.4 | 99.0 | 5.55 | 14.1 | 5.97 |
| | | | | 70 | 108.9 | 88.1 | 112.9 | 6.23 | 5.12 | 94.5 | 90.1 | 107.2 | 5.86 | 14.4 | 5.45 |
| | | | | 80 | 104.6 | 82.9 | 121.2 | 6.54 | 4.69 | 89.9 | 84.7 | 115.4 | 6.15 | 14.7 | 4.98 |

Notes:

1. Capacity data includes water pumping watts and are base upon 15% (by volume) propylene glycol antifreeze solution.
2. Desuperheater Capacity is based upon 0.4 GPM Flow per nominal ton at 90°F entering hot water temperature.
3. The manufacturer reserves the right to make changes in design and construction at any time without notice.
4. Extrapolation data down to 25°F for heating and interpolation between CFM, EWT & GPM data is permissible.
5. See Flow Rate Selection on page 7 for proper application.

GT072 Performance Data: 6.0 Ton, 1650 CFM, Low Capacity Heating

| EWT | GPM | WPD | | Heating | | | | | | Heating with Desuperheater | | | | | |
|-----|------|-----|------|---------|------|------|-------|------|------|----------------------------|------|-------|------|------|------|
| | | PSI | FT | EAT | HC | HE | LAT | KW | COP | HC | HE | LAT | KW | DH | COP |
| 30 | 8.3 | 2.6 | 6.0 | 60 | 44.6 | 32.0 | 85.0 | 3.65 | 3.58 | 39.0 | 32.0 | 81.9 | 3.61 | 5.5 | 3.62 |
| | | | | 70 | 43.3 | 30.1 | 94.3 | 3.84 | 3.30 | 37.6 | 30.3 | 91.1 | 3.77 | 5.7 | 3.36 |
| | | | | 80 | 41.9 | 28.4 | 103.5 | 4.03 | 3.05 | 36.1 | 28.4 | 100.2 | 3.95 | 5.9 | 3.11 |
| | 11.7 | 4.8 | 11.2 | 60 | 45.9 | 33.3 | 85.8 | 3.69 | 3.65 | 40.2 | 33.4 | 82.6 | 3.61 | 5.7 | 3.73 |
| | | | | 70 | 44.6 | 31.4 | 95.1 | 3.88 | 3.37 | 38.7 | 31.5 | 91.7 | 3.80 | 5.9 | 3.44 |
| | | | | 80 | 43.4 | 29.5 | 104.4 | 4.08 | 3.12 | 37.3 | 29.7 | 100.9 | 3.99 | 6.1 | 3.19 |
| | 15.0 | 7.8 | 17.9 | 60 | 46.5 | 34.0 | 86.1 | 3.68 | 3.70 | 40.7 | 34.2 | 82.8 | 3.60 | 5.8 | 3.78 |
| | | | | 70 | 45.3 | 32.1 | 95.4 | 3.88 | 3.42 | 39.3 | 27.6 | 92.1 | 3.80 | 6.0 | 3.49 |
| | | | | 80 | 44.1 | 30.1 | 104.7 | 4.07 | 3.17 | 37.9 | 30.3 | 101.3 | 4.00 | 6.2 | 3.23 |
| 50 | 8.3 | 2.4 | 5.6 | 60 | 57.6 | 44.7 | 92.3 | 3.82 | 4.42 | 50.5 | 45.1 | 88.3 | 3.70 | 7.2 | 4.57 |
| | | | | 70 | 55.9 | 42.1 | 101.4 | 4.03 | 4.07 | 48.5 | 42.4 | 97.2 | 3.90 | 7.4 | 4.20 |
| | | | | 80 | 54.0 | 39.6 | 110.3 | 4.22 | 3.75 | 46.4 | 39.9 | 106.1 | 4.10 | 7.6 | 3.86 |
| | 11.7 | 4.5 | 10.4 | 60 | 60.1 | 46.8 | 93.7 | 3.90 | 4.52 | 52.6 | 47.3 | 89.5 | 3.77 | 7.5 | 4.67 |
| | | | | 70 | 58.1 | 44.2 | 102.6 | 4.10 | 4.15 | 50.4 | 44.6 | 98.3 | 3.97 | 7.7 | 4.29 |
| | | | | 80 | 56.2 | 41.4 | 111.6 | 4.31 | 3.82 | 48.3 | 41.9 | 107.1 | 4.17 | 7.9 | 3.95 |
| | 15.0 | 7.2 | 16.7 | 60 | 61.3 | 48.0 | 94.4 | 3.92 | 4.59 | 53.7 | 48.4 | 90.1 | 3.77 | 7.6 | 4.76 |
| | | | | 70 | 59.3 | 45.3 | 103.3 | 4.12 | 4.22 | 51.5 | 45.8 | 98.9 | 3.99 | 7.8 | 4.36 |
| | | | | 80 | 57.3 | 42.6 | 112.2 | 4.33 | 3.88 | 49.3 | 43.1 | 107.7 | 4.19 | 8.1 | 4.01 |
| 70 | 8.3 | 2.4 | 5.6 | 60 | 70.1 | 56.4 | 99.4 | 4.06 | 5.06 | 61.4 | 57.1 | 94.5 | 3.88 | 8.7 | 5.30 |
| | | | | 70 | 67.7 | 53.1 | 108.0 | 4.27 | 4.64 | 58.7 | 53.8 | 102.9 | 4.09 | 8.9 | 4.85 |
| | | | | 80 | 65.2 | 49.9 | 116.6 | 4.48 | 4.26 | 56.0 | 50.7 | 111.4 | 4.29 | 9.1 | 4.45 |
| | 11.7 | 4.3 | 10.0 | 60 | 73.7 | 59.3 | 101.3 | 4.18 | 5.16 | 64.5 | 60.3 | 96.2 | 3.99 | 9.2 | 5.41 |
| | | | | 70 | 71.0 | 56.0 | 109.9 | 4.40 | 4.73 | 61.6 | 56.8 | 104.6 | 4.20 | 9.4 | 4.95 |
| | | | | 80 | 68.4 | 52.6 | 118.4 | 4.63 | 4.33 | 58.8 | 53.4 | 113.0 | 4.42 | 9.6 | 4.54 |
| | 15.0 | 6.9 | 15.9 | 60 | 75.6 | 61.2 | 102.4 | 4.23 | 5.24 | 66.2 | 62.2 | 97.2 | 4.02 | 9.4 | 5.51 |
| | | | | 70 | 72.9 | 57.7 | 110.9 | 4.45 | 4.80 | 63.3 | 58.7 | 105.5 | 4.24 | 9.6 | 5.04 |
| | | | | 80 | 70.2 | 54.2 | 119.4 | 4.67 | 4.40 | 60.3 | 55.2 | 113.8 | 4.45 | 9.9 | 4.62 |
| 90 | 8.3 | 2.2 | 5.2 | 60 | 80.9 | 66.4 | 105.4 | 4.03 | 5.88 | 70.8 | 67.7 | 99.7 | 4.01 | 10.1 | 5.91 |
| | | | | 70 | 77.9 | 62.6 | 113.7 | 4.56 | 5.01 | 67.6 | 63.8 | 107.9 | 4.23 | 10.3 | 5.40 |
| | | | | 80 | 74.9 | 58.8 | 122.0 | 4.69 | 4.68 | 64.4 | 60.0 | 116.1 | 4.44 | 10.5 | 4.94 |
| | 11.7 | 4.0 | 9.2 | 60 | 85.5 | 70.4 | 108.0 | 4.43 | 5.66 | 74.8 | 71.8 | 102.0 | 4.16 | 10.6 | 6.02 |
| | | | | 70 | 82.4 | 66.4 | 116.2 | 4.66 | 5.18 | 71.5 | 67.8 | 110.1 | 4.39 | 10.9 | 5.50 |
| | | | | 80 | 79.1 | 62.5 | 124.4 | 4.89 | 4.74 | 68.0 | 63.7 | 118.2 | 4.61 | 11.1 | 5.03 |
| | 15.0 | 6.4 | 14.7 | 60 | 88.3 | 72.9 | 109.6 | 4.49 | 5.76 | 77.3 | 74.5 | 103.4 | 4.21 | 11.0 | 6.14 |
| | | | | 70 | 85.0 | 68.8 | 117.7 | 4.73 | 5.27 | 73.7 | 70.3 | 111.4 | 4.45 | 11.2 | 5.60 |
| | | | | 80 | 81.6 | 64.7 | 125.8 | 4.96 | 4.82 | 70.2 | 66.1 | 119.4 | 4.67 | 11.5 | 5.12 |

Notes:

- Capacity data includes water pumping watts and are base upon 15% (by volume) propylene glycol antifreeze solution.
- Desuperheater Capacity is based upon 0.4 GPM Flow per nominal ton at 90°F entering hot water temperature.
- The manufacturer reserves the right to make changes in design and construction at any time without notice.
- Extrapolation data down to 25°F for heating and interpolation between CFM, EWT & GPM data is permissible.
- See Flow Rate Selection on page 7 for proper application.

GT072 Performance Data: 6.0 Ton, 2350 CFM, High Capacity Cooling

| EWT | GPM | WPD | | EAT DB/ WB | Cooling | | | | | Cooling with Desuperheater | | | | | |
|-----|------|-----|------|------------------|---------|------|------|------|------|----------------------------|------|------|------|------|------|
| | | PSI | FT | | TC | SC | HR | KW | EER | TC | SC | HR | KW | DH | EER |
| 50 | 10.0 | 3.1 | 7.2 | 75/63 | 71.1 | 49.7 | 83.7 | 4.65 | 15.3 | 71.1 | 49.8 | 83.7 | 4.57 | 6.0 | 15.6 |
| | | | | 80/67 | 77.2 | 51.7 | 89.1 | 4.76 | 16.2 | 77.2 | 51.8 | 89.0 | 4.66 | 6.1 | 16.6 |
| | | | | 85/71 | 83.4 | 53.8 | 94.4 | 4.86 | 17.2 | 83.4 | 53.9 | 94.4 | 4.76 | 6.3 | 17.5 |
| | 14.0 | 5.6 | 13.0 | 75/63 | 71.8 | 50.1 | 84.0 | 4.45 | 16.1 | 71.8 | 50.2 | 84.0 | 4.39 | 5.7 | 16.4 |
| | | | | 80/67 | 78.0 | 52.2 | 89.2 | 4.54 | 17.2 | 78.0 | 52.3 | 89.4 | 4.48 | 5.8 | 17.4 |
| | | | | 85/71 | 84.3 | 54.2 | 94.7 | 4.63 | 18.2 | 84.3 | 54.3 | 94.7 | 4.58 | 6.0 | 18.4 |
| | 18.0 | 9.1 | 21.0 | 75/63 | 72.5 | 50.1 | 84.4 | 4.32 | 16.8 | 72.5 | 50.2 | 84.4 | 4.30 | 5.4 | 16.9 |
| | | | | 80/67 | 78.8 | 52.2 | 89.8 | 4.40 | 17.9 | 78.8 | 52.3 | 89.8 | 4.39 | 5.5 | 18.0 |
| | | | | 85/71 | 85.1 | 54.2 | 95.1 | 4.50 | 18.9 | 85.1 | 54.3 | 95.3 | 4.46 | 5.7 | 19.1 |
| 70 | 10.0 | 3.0 | 7.0 | 75/63 | 66.7 | 48.8 | 81.5 | 5.60 | 11.9 | 67.1 | 48.9 | 81.6 | 5.46 | 8.6 | 12.3 |
| | | | | 80/67 | 72.4 | 50.7 | 86.6 | 5.73 | 12.6 | 72.8 | 50.9 | 86.8 | 5.57 | 8.9 | 13.1 |
| | | | | 85/71 | 78.2 | 52.8 | 91.9 | 5.82 | 13.4 | 78.7 | 53.0 | 92.0 | 5.70 | 9.2 | 13.8 |
| | 14.0 | 5.4 | 12.5 | 75/63 | 67.7 | 49.2 | 81.8 | 5.33 | 12.7 | 68.1 | 49.5 | 82.1 | 5.24 | 8.3 | 13.0 |
| | | | | 80/67 | 73.6 | 51.3 | 87.0 | 5.44 | 13.5 | 74.0 | 51.5 | 87.3 | 5.36 | 8.6 | 13.8 |
| | | | | 85/71 | 79.4 | 53.3 | 92.3 | 5.55 | 14.3 | 79.9 | 53.6 | 92.6 | 5.44 | 8.8 | 14.7 |
| | 18.0 | 8.6 | 20.0 | 75/63 | 68.3 | 49.2 | 82.2 | 5.16 | 13.2 | 68.7 | 49.5 | 82.5 | 5.14 | 7.9 | 13.4 |
| | | | | 80/67 | 74.3 | 51.3 | 87.5 | 5.27 | 14.1 | 74.7 | 51.5 | 87.8 | 5.24 | 8.2 | 14.2 |
| | | | | 85/71 | 80.2 | 53.3 | 92.6 | 5.38 | 14.9 | 80.6 | 53.6 | 93.1 | 5.33 | 8.5 | 15.1 |
| 90 | 10.0 | 2.8 | 6.5 | 75/63 | 60.7 | 46.7 | 78.4 | 6.92 | 8.8 | 61.2 | 47.1 | 78.7 | 6.71 | 11.4 | 9.1 |
| | | | | 80/67 | 65.9 | 48.6 | 83.4 | 7.05 | 9.4 | 66.6 | 49.0 | 83.7 | 6.85 | 11.7 | 9.7 |
| | | | | 85/71 | 71.2 | 50.7 | 88.5 | 7.17 | 9.9 | 71.9 | 50.9 | 88.8 | 6.98 | 12.0 | 10.3 |
| | 14.0 | 5.0 | 11.6 | 75/63 | 61.8 | 47.2 | 78.8 | 6.51 | 9.5 | 62.4 | 47.6 | 79.3 | 6.38 | 10.9 | 9.8 |
| | | | | 80/67 | 67.3 | 49.2 | 83.8 | 6.67 | 10.1 | 67.9 | 49.5 | 84.3 | 6.50 | 11.2 | 10.4 |
| | | | | 85/71 | 72.7 | 51.1 | 88.8 | 6.77 | 10.7 | 73.4 | 51.5 | 89.4 | 6.65 | 11.5 | 11.0 |
| | 18.0 | 8.1 | 18.6 | 75/63 | 62.6 | 47.2 | 79.0 | 6.34 | 9.9 | 63.2 | 47.6 | 79.6 | 6.27 | 10.5 | 10.1 |
| | | | | 80/67 | 68.0 | 49.2 | 84.0 | 6.46 | 10.5 | 68.6 | 49.5 | 84.7 | 6.39 | 10.8 | 10.7 |
| | | | | 85/71 | 73.4 | 51.1 | 89.1 | 6.61 | 11.1 | 74.1 | 51.5 | 89.8 | 6.50 | 11.1 | 11.4 |
| 110 | 10.0 | 2.7 | 6.2 | 75/63 | 52.9 | 43.8 | 74.6 | 8.62 | 6.1 | 53.8 | 44.2 | 74.9 | 8.37 | 14.0 | 6.4 |
| | | | | 80/67 | 57.4 | 45.6 | 79.4 | 8.74 | 6.6 | 58.4 | 45.9 | 79.7 | 8.51 | 14.4 | 6.9 |
| | | | | 85/71 | 62.1 | 47.3 | 84.1 | 8.95 | 6.9 | 63.2 | 47.9 | 84.4 | 8.65 | 14.9 | 7.3 |
| | 14.0 | 5.0 | 11.5 | 75/63 | 54.2 | 44.3 | 74.9 | 8.07 | 6.7 | 55.1 | 44.6 | 75.3 | 7.94 | 13.6 | 6.9 |
| | | | | 80/67 | 59.1 | 46.0 | 79.6 | 8.25 | 7.2 | 60.1 | 46.4 | 80.1 | 8.06 | 14.0 | 7.5 |
| | | | | 85/71 | 63.7 | 47.9 | 84.4 | 8.47 | 7.5 | 64.8 | 48.3 | 85.0 | 8.21 | 14.3 | 7.9 |
| | 18.0 | 7.9 | 18.2 | 75/63 | 54.8 | 44.3 | 74.9 | 7.90 | 6.9 | 55.7 | 44.6 | 75.6 | 7.78 | 13.0 | 7.2 |
| | | | | 80/67 | 59.6 | 46.0 | 79.6 | 8.00 | 7.5 | 60.6 | 46.4 | 80.4 | 7.98 | 13.4 | 7.6 |
| | | | | 85/71 | 64.3 | 47.9 | 84.4 | 8.15 | 7.9 | 65.4 | 48.3 | 85.3 | 8.07 | 13.9 | 8.1 |

Notes:

1. Capacity data includes water pumping watts and are base upon 15% (by volume) propylene glycol antifreeze solution.
2. Desuperheater Capacity is based upon 0.4 GPM Flow per nominal ton at 90°F entering hot water temperature.
3. The manufacturer reserves the right to make changes in design and construction at any time without notice.
4. Extrapolation data down to 25°F for heating and interpolation between CFM, EWT & GPM data is permissible.
5. See Flow Rate Selection on page 7 for proper application.

GT072 Performance Data: 6.0 Ton, 1650 CFM, Low Capacity Cooling

| EWT | GPM | WPD | | EAT DB/ WB | Cooling | | | | | Cooling with Desuperheater | | | | | |
|-----|------|-----|------|------------------|---------|------|------|------|------|----------------------------|------|------|------|------|------|
| | | PSI | FT | | TC | SC | HR | KW | EER | TC | SC | HR | KW | DH | EER |
| 50 | 8.3 | 2.5 | 5.8 | 75/63 | 56.8 | 39.7 | 66.8 | 2.73 | 20.8 | 56.8 | 39.7 | 66.8 | 2.68 | 4.8 | 21.2 |
| | | | | 80/67 | 61.7 | 41.3 | 71.1 | 2.79 | 22.1 | 61.7 | 41.4 | 71.0 | 2.73 | 4.9 | 22.6 |
| | | | | 85/71 | 66.6 | 42.9 | 75.4 | 2.85 | 23.4 | 66.6 | 43.0 | 75.4 | 2.79 | 5.0 | 23.9 |
| | 11.7 | 4.5 | 10.3 | 75/63 | 57.3 | 40.0 | 67.1 | 2.61 | 22.0 | 57.3 | 40.1 | 67.1 | 2.57 | 4.5 | 22.3 |
| | | | | 80/67 | 62.3 | 41.7 | 71.3 | 2.66 | 23.4 | 62.3 | 41.7 | 71.4 | 2.63 | 4.7 | 23.7 |
| | | | | 85/71 | 67.3 | 43.3 | 75.6 | 2.72 | 24.8 | 67.3 | 43.4 | 75.6 | 2.68 | 4.8 | 25.1 |
| | 15.0 | 7.2 | 16.7 | 75/63 | 57.9 | 40.0 | 67.4 | 2.53 | 22.9 | 57.9 | 40.1 | 67.4 | 2.52 | 4.3 | 23.0 |
| | | | | 80/67 | 63.0 | 41.7 | 71.7 | 2.58 | 24.4 | 63.0 | 41.7 | 71.7 | 2.57 | 4.4 | 24.5 |
| | | | | 85/71 | 68.0 | 43.3 | 75.9 | 2.64 | 25.8 | 68.0 | 43.4 | 76.1 | 2.62 | 4.5 | 26.0 |
| 70 | 8.3 | 2.4 | 5.6 | 75/63 | 53.2 | 39.0 | 65.1 | 3.28 | 16.2 | 53.6 | 39.0 | 65.2 | 3.20 | 6.9 | 16.7 |
| | | | | 80/67 | 57.8 | 40.5 | 69.2 | 3.36 | 17.2 | 58.1 | 40.7 | 69.3 | 3.27 | 7.1 | 17.8 |
| | | | | 85/71 | 62.5 | 42.1 | 73.4 | 3.41 | 18.3 | 62.9 | 42.3 | 73.5 | 3.34 | 7.3 | 18.8 |
| | 11.7 | 4.3 | 9.9 | 75/63 | 54.1 | 39.3 | 65.3 | 3.12 | 17.3 | 54.4 | 39.5 | 65.5 | 3.07 | 6.6 | 17.7 |
| | | | | 80/67 | 58.7 | 41.0 | 69.5 | 3.19 | 18.4 | 59.1 | 41.1 | 69.8 | 3.14 | 6.9 | 18.8 |
| | | | | 85/71 | 63.4 | 42.6 | 73.7 | 3.25 | 19.5 | 63.8 | 42.8 | 74.0 | 3.19 | 7.0 | 20.0 |
| | 15.0 | 6.9 | 15.9 | 75/63 | 54.5 | 39.3 | 65.6 | 3.03 | 18.0 | 54.8 | 39.5 | 65.9 | 3.01 | 6.3 | 18.2 |
| | | | | 80/67 | 59.3 | 41.0 | 69.9 | 3.09 | 19.2 | 59.7 | 41.2 | 70.1 | 3.08 | 6.5 | 19.4 |
| | | | | 85/71 | 64.0 | 42.6 | 74.0 | 3.15 | 20.3 | 64.4 | 42.8 | 74.3 | 3.13 | 6.8 | 20.6 |
| 90 | 8.3 | 2.2 | 5.2 | 75/63 | 48.4 | 37.3 | 62.6 | 4.06 | 11.9 | 48.9 | 37.6 | 62.8 | 3.93 | 9.1 | 12.4 |
| | | | | 80/67 | 52.7 | 38.9 | 66.6 | 4.14 | 12.7 | 53.2 | 39.2 | 66.8 | 4.02 | 9.3 | 13.2 |
| | | | | 85/71 | 56.9 | 40.5 | 70.7 | 4.20 | 13.5 | 57.4 | 40.7 | 70.9 | 4.09 | 9.6 | 14.0 |
| | 11.7 | 4.0 | 9.2 | 75/63 | 49.4 | 37.7 | 63.0 | 3.82 | 12.9 | 49.9 | 38.0 | 63.3 | 3.74 | 8.7 | 13.3 |
| | | | | 80/67 | 53.7 | 39.3 | 66.9 | 3.91 | 13.7 | 54.2 | 39.5 | 67.3 | 3.81 | 9.0 | 14.2 |
| | | | | 85/71 | 58.0 | 40.8 | 70.9 | 3.97 | 14.6 | 58.6 | 41.1 | 71.4 | 3.90 | 9.2 | 15.0 |
| | 15.0 | 6.4 | 14.8 | 75/63 | 50.0 | 37.7 | 63.1 | 3.72 | 13.4 | 50.4 | 38.0 | 63.5 | 3.67 | 8.4 | 13.7 |
| | | | | 80/67 | 54.3 | 39.3 | 67.1 | 3.79 | 14.3 | 54.8 | 39.5 | 67.6 | 3.75 | 8.6 | 14.6 |
| | | | | 85/71 | 58.6 | 40.8 | 71.1 | 3.88 | 15.1 | 59.2 | 41.1 | 71.7 | 3.81 | 8.9 | 15.5 |
| 110 | 8.3 | 2.2 | 5.0 | 75/63 | 42.2 | 35.0 | 59.6 | 5.06 | 8.4 | 43.0 | 35.3 | 59.8 | 4.91 | 11.2 | 8.8 |
| | | | | 80/67 | 45.9 | 36.4 | 63.4 | 5.12 | 9.0 | 46.6 | 36.7 | 63.7 | 4.99 | 11.5 | 9.4 |
| | | | | 85/71 | 49.6 | 37.8 | 67.2 | 5.25 | 9.5 | 50.5 | 38.2 | 67.4 | 5.07 | 11.9 | 9.9 |
| | 11.7 | 4.0 | 9.1 | 75/63 | 43.3 | 35.3 | 59.8 | 4.73 | 9.2 | 44.0 | 35.6 | 60.1 | 4.66 | 10.8 | 9.5 |
| | | | | 80/67 | 47.2 | 36.7 | 63.5 | 4.84 | 9.7 | 48.0 | 37.0 | 64.0 | 4.73 | 11.2 | 10.1 |
| | | | | 85/71 | 50.9 | 38.3 | 67.4 | 4.97 | 10.2 | 51.8 | 38.6 | 67.9 | 4.82 | 11.4 | 10.7 |
| | 15.0 | 6.3 | 14.5 | 75/63 | 43.8 | 35.3 | 59.8 | 4.63 | 9.5 | 44.5 | 35.6 | 60.4 | 4.56 | 10.4 | 9.7 |
| | | | | 80/67 | 47.6 | 36.7 | 63.5 | 4.69 | 10.1 | 48.4 | 37.0 | 64.2 | 4.68 | 10.7 | 10.3 |
| | | | | 85/71 | 51.4 | 38.3 | 67.4 | 4.78 | 10.7 | 52.2 | 38.6 | 68.1 | 4.73 | 11.1 | 11.0 |

Notes:

- Capacity data includes water pumping watts and are base upon 15% (by volume) propylene glycol antifreeze solution.
- Desuperheater Capacity is based upon 0.4 GPM Flow per nominal ton at 90°F entering hot water temperature.
- The manufacturer reserves the right to make changes in design and construction at any time without notice.
- Extrapolation data down to 25°F for heating and interpolation between CFM, EWT & GPM data is permissible.
- See Flow Rate Selection on page 7 for proper application.

GT096 Performance Data: 8.0 Ton, 3200 CFM, High Capacity Heating

| EWT | GPM | WPD | | Heating | | | | | | Heating with Desuperheater | | | | | |
|-----|------|-----|------|---------|-------|-------|-------|------|------|----------------------------|-------|-------|------|------|------|
| | | PSI | FT | EAT | HC | HE | LAT | KW | COP | HC | HE | LAT | KW | DH | COP |
| 30 | 14.5 | 2.2 | 5.0 | 60 | 82.4 | 59.1 | 83.8 | 6.94 | 3.48 | 72.2 | 59.3 | 80.9 | 6.86 | 10.3 | 3.52 |
| | | | | 70 | 80.1 | 55.7 | 93.2 | 7.32 | 3.21 | 69.5 | 56.0 | 90.1 | 7.18 | 10.6 | 3.27 |
| | | | | 80 | 77.6 | 52.5 | 102.4 | 7.67 | 2.97 | 66.7 | 52.6 | 99.3 | 7.52 | 10.9 | 3.03 |
| | 20.2 | 4.0 | 9.3 | 60 | 84.9 | 61.7 | 84.6 | 7.02 | 3.55 | 74.4 | 61.8 | 81.5 | 6.86 | 10.6 | 3.63 |
| | | | | 70 | 82.6 | 58.0 | 93.9 | 7.39 | 3.28 | 71.7 | 58.3 | 90.7 | 7.23 | 10.9 | 3.35 |
| | | | | 80 | 80.3 | 54.5 | 103.2 | 7.76 | 3.03 | 69.1 | 54.9 | 100.0 | 7.59 | 11.3 | 3.10 |
| | 26.0 | 6.5 | 15.0 | 60 | 86.0 | 62.8 | 84.9 | 7.01 | 3.60 | 75.3 | 63.2 | 81.8 | 6.86 | 10.7 | 3.68 |
| | | | | 70 | 83.8 | 59.4 | 94.2 | 7.38 | 3.33 | 72.7 | 51.1 | 91.0 | 7.24 | 11.1 | 3.39 |
| | | | | 80 | 81.5 | 55.7 | 103.6 | 7.75 | 3.08 | 70.1 | 56.0 | 100.3 | 7.60 | 11.4 | 3.14 |
| 50 | 14.5 | 2.0 | 4.7 | 60 | 106.6 | 82.6 | 90.9 | 7.27 | 4.30 | 93.4 | 83.4 | 87.0 | 7.03 | 13.3 | 4.45 |
| | | | | 70 | 103.4 | 77.8 | 99.9 | 7.66 | 3.96 | 89.8 | 78.5 | 96.0 | 7.42 | 13.7 | 4.09 |
| | | | | 80 | 99.9 | 73.2 | 108.9 | 8.03 | 3.65 | 85.9 | 73.9 | 104.9 | 7.80 | 14.0 | 3.75 |
| | 20.2 | 3.7 | 8.6 | 60 | 111.2 | 86.5 | 92.2 | 7.41 | 4.39 | 97.3 | 87.5 | 88.2 | 7.17 | 13.8 | 4.54 |
| | | | | 70 | 107.5 | 81.7 | 101.1 | 7.81 | 4.03 | 93.3 | 82.4 | 97.0 | 7.55 | 14.2 | 4.17 |
| | | | | 80 | 104.0 | 76.6 | 110.1 | 8.21 | 3.71 | 89.4 | 77.6 | 105.9 | 7.94 | 14.6 | 3.84 |
| | 26.0 | 6.0 | 14.0 | 60 | 113.4 | 88.8 | 92.8 | 7.45 | 4.46 | 99.3 | 89.6 | 88.7 | 7.18 | 14.1 | 4.63 |
| | | | | 70 | 109.8 | 83.8 | 101.8 | 7.84 | 4.10 | 95.3 | 84.7 | 97.6 | 7.59 | 14.5 | 4.24 |
| | | | | 80 | 106.0 | 78.7 | 110.7 | 8.24 | 3.77 | 91.2 | 79.6 | 106.4 | 7.97 | 14.9 | 3.90 |
| 70 | 14.5 | 2.0 | 4.7 | 60 | 129.8 | 104.3 | 97.5 | 7.73 | 4.92 | 113.6 | 105.6 | 92.9 | 7.38 | 16.2 | 5.16 |
| | | | | 70 | 125.1 | 98.3 | 106.2 | 8.13 | 4.51 | 108.6 | 99.6 | 101.4 | 7.77 | 16.5 | 4.72 |
| | | | | 80 | 120.5 | 92.3 | 114.9 | 8.53 | 4.14 | 103.6 | 93.8 | 110.0 | 8.16 | 16.9 | 4.33 |
| | 20.2 | 3.6 | 8.3 | 60 | 136.2 | 109.8 | 99.4 | 7.96 | 5.02 | 119.3 | 111.6 | 94.5 | 7.59 | 17.0 | 5.26 |
| | | | | 70 | 131.4 | 103.6 | 108.0 | 8.38 | 4.60 | 114.0 | 105.1 | 103.0 | 8.00 | 17.4 | 4.81 |
| | | | | 80 | 126.6 | 97.3 | 116.6 | 8.81 | 4.21 | 108.8 | 98.9 | 111.5 | 8.40 | 17.8 | 4.42 |
| | 26.0 | 5.8 | 13.3 | 60 | 139.9 | 113.2 | 100.5 | 8.05 | 5.09 | 122.5 | 115.1 | 95.4 | 7.65 | 17.4 | 5.36 |
| | | | | 70 | 134.9 | 106.8 | 109.0 | 8.47 | 4.67 | 117.0 | 108.6 | 103.9 | 8.06 | 17.8 | 4.90 |
| | | | | 80 | 129.8 | 100.3 | 117.6 | 8.89 | 4.28 | 111.6 | 102.1 | 112.3 | 8.47 | 18.2 | 4.49 |
| 90 | 14.5 | 1.9 | 4.3 | 60 | 149.6 | 122.9 | 103.3 | 7.67 | 5.72 | 131.0 | 125.3 | 97.9 | 7.63 | 18.6 | 5.75 |
| | | | | 70 | 144.1 | 115.8 | 111.7 | 8.67 | 4.87 | 125.0 | 118.1 | 106.2 | 8.04 | 19.0 | 5.25 |
| | | | | 80 | 138.5 | 108.9 | 120.1 | 8.92 | 4.55 | 119.1 | 110.9 | 114.5 | 8.45 | 19.5 | 4.80 |
| | 20.2 | 3.3 | 7.7 | 60 | 158.1 | 130.3 | 105.7 | 8.42 | 5.50 | 138.4 | 132.9 | 100.1 | 7.91 | 19.7 | 5.86 |
| | | | | 70 | 152.4 | 122.9 | 114.1 | 8.87 | 5.04 | 132.2 | 125.5 | 108.3 | 8.35 | 20.1 | 5.35 |
| | | | | 80 | 146.4 | 115.5 | 122.4 | 9.31 | 4.61 | 125.8 | 117.8 | 116.4 | 8.77 | 20.6 | 4.89 |
| | 26.0 | 5.3 | 12.3 | 60 | 163.4 | 134.9 | 107.3 | 8.55 | 5.60 | 143.1 | 137.8 | 101.4 | 8.02 | 20.3 | 5.97 |
| | | | | 70 | 157.2 | 127.3 | 115.5 | 8.99 | 5.12 | 136.4 | 130.1 | 109.5 | 8.46 | 20.8 | 5.45 |
| | | | | 80 | 151.0 | 119.7 | 123.7 | 9.44 | 4.69 | 129.8 | 122.2 | 117.6 | 8.89 | 21.2 | 4.98 |

Notes:

1. Capacity data includes water pumping watts and are base upon 15% (by volume) propylene glycol antifreeze solution.
2. Desuperheater Capacity is based upon 0.4 GPM Flow per nominal ton at 90°F entering hot water temperature.
3. The manufacturer reserves the right to make changes in design and construction at any time without notice.
4. Extrapolation data down to 25°F for heating and interpolation between CFM, EWT & GPM data is permissible.
5. See Flow Rate Selection on page 7 for proper application.

GT096 Performance Data: 8.0 Ton, 1600 CFM, Low Capacity Heating

| EWT | GPM | WPD | | Heating | | | | | | Heating with Desuperheater | | | | | |
|-----|------|-----|------|---------|------|------|-------|------|------|----------------------------|------|-------|------|------|------|
| | | PSI | FT | EAT | HC | HE | LAT | KW | COP | HC | HE | LAT | KW | DH | COP |
| 30 | 7.2 | 2.1 | 4.9 | 60 | 41.2 | 29.6 | 83.8 | 3.57 | 3.38 | 36.1 | 29.6 | 80.9 | 3.53 | 5.1 | 3.42 |
| | | | | 70 | 40.0 | 27.8 | 93.2 | 3.77 | 3.12 | 34.7 | 28.0 | 90.1 | 3.70 | 5.3 | 3.17 |
| | | | | 80 | 38.8 | 26.2 | 102.4 | 3.95 | 2.88 | 33.3 | 26.3 | 99.3 | 3.87 | 5.4 | 2.94 |
| | 10.1 | 3.9 | 9.1 | 60 | 42.5 | 30.8 | 84.6 | 3.61 | 3.45 | 37.2 | 30.9 | 81.5 | 3.53 | 5.3 | 3.52 |
| | | | | 70 | 41.3 | 29.0 | 93.9 | 3.80 | 3.18 | 35.8 | 29.2 | 90.7 | 3.72 | 5.5 | 3.25 |
| | | | | 80 | 40.2 | 27.3 | 103.2 | 3.99 | 2.95 | 34.5 | 27.4 | 100.0 | 3.91 | 5.6 | 3.01 |
| | 13.0 | 6.3 | 14.6 | 60 | 43.0 | 31.4 | 84.9 | 3.61 | 3.49 | 37.7 | 31.6 | 81.8 | 3.53 | 5.4 | 3.57 |
| | | | | 70 | 41.9 | 29.7 | 94.2 | 3.80 | 3.23 | 36.3 | 25.5 | 91.0 | 3.72 | 5.5 | 3.30 |
| | | | | 80 | 40.8 | 27.8 | 103.6 | 3.99 | 2.99 | 35.0 | 28.0 | 100.3 | 3.91 | 5.7 | 3.05 |
| 50 | 7.2 | 2.0 | 4.5 | 60 | 53.3 | 41.3 | 90.9 | 3.74 | 4.17 | 46.7 | 41.7 | 87.0 | 3.62 | 6.6 | 4.32 |
| | | | | 70 | 51.7 | 38.9 | 99.9 | 3.94 | 3.84 | 44.9 | 39.2 | 96.0 | 3.82 | 6.8 | 3.97 |
| | | | | 80 | 50.0 | 36.6 | 108.9 | 4.13 | 3.54 | 43.0 | 36.9 | 104.9 | 4.02 | 7.0 | 3.65 |
| | 10.1 | 3.6 | 8.4 | 60 | 55.6 | 43.3 | 92.2 | 3.82 | 4.27 | 48.7 | 43.8 | 88.2 | 3.69 | 6.9 | 4.41 |
| | | | | 70 | 53.7 | 40.9 | 101.1 | 4.02 | 3.92 | 46.6 | 41.2 | 97.0 | 3.89 | 7.1 | 4.05 |
| | | | | 80 | 52.0 | 38.3 | 110.1 | 4.23 | 3.61 | 44.7 | 38.8 | 105.9 | 4.08 | 7.3 | 3.73 |
| | 13.0 | 5.9 | 13.6 | 60 | 56.7 | 44.4 | 92.8 | 3.83 | 4.34 | 49.6 | 44.8 | 88.7 | 3.70 | 7.1 | 4.50 |
| | | | | 70 | 54.9 | 41.9 | 101.8 | 4.04 | 3.99 | 47.6 | 42.4 | 97.6 | 3.90 | 7.3 | 4.12 |
| | | | | 80 | 53.0 | 39.4 | 110.7 | 4.24 | 3.66 | 45.6 | 39.8 | 106.4 | 4.10 | 7.4 | 3.79 |
| 70 | 7.2 | 2.0 | 4.5 | 60 | 64.9 | 52.1 | 97.5 | 3.98 | 4.78 | 56.8 | 52.8 | 92.9 | 3.80 | 8.1 | 5.01 |
| | | | | 70 | 62.6 | 49.1 | 106.2 | 4.18 | 4.38 | 54.3 | 49.8 | 101.4 | 4.00 | 8.3 | 4.58 |
| | | | | 80 | 60.3 | 46.1 | 114.9 | 4.39 | 4.02 | 51.8 | 46.9 | 110.0 | 4.20 | 8.5 | 4.20 |
| | 10.1 | 3.5 | 8.1 | 60 | 68.1 | 54.9 | 99.4 | 4.10 | 4.87 | 59.6 | 55.8 | 94.5 | 3.91 | 8.5 | 5.11 |
| | | | | 70 | 65.7 | 51.8 | 108.0 | 4.31 | 4.47 | 57.0 | 52.6 | 103.0 | 4.12 | 8.7 | 4.68 |
| | | | | 80 | 63.3 | 48.6 | 116.6 | 4.54 | 4.09 | 54.4 | 49.4 | 111.5 | 4.32 | 8.9 | 4.29 |
| | 13.0 | 5.6 | 12.9 | 60 | 70.0 | 56.6 | 100.5 | 4.14 | 4.95 | 61.3 | 57.5 | 95.4 | 3.94 | 8.7 | 5.21 |
| | | | | 70 | 67.4 | 53.4 | 109.0 | 4.36 | 4.53 | 58.5 | 54.3 | 103.9 | 4.15 | 8.9 | 4.76 |
| | | | | 80 | 64.9 | 50.2 | 117.6 | 4.58 | 4.16 | 55.8 | 51.1 | 112.3 | 4.36 | 9.1 | 4.37 |
| 90 | 7.2 | 1.8 | 4.2 | 60 | 74.8 | 61.4 | 103.3 | 3.95 | 5.55 | 65.5 | 62.6 | 97.9 | 3.93 | 9.3 | 5.58 |
| | | | | 70 | 72.0 | 57.9 | 111.7 | 4.46 | 4.73 | 62.5 | 59.0 | 106.2 | 4.14 | 9.5 | 5.10 |
| | | | | 80 | 69.3 | 54.4 | 120.1 | 4.59 | 4.42 | 59.5 | 55.5 | 114.5 | 4.35 | 9.7 | 4.67 |
| | 10.1 | 3.2 | 7.4 | 60 | 79.1 | 65.1 | 105.7 | 4.33 | 5.35 | 69.2 | 66.4 | 100.1 | 4.07 | 9.8 | 5.69 |
| | | | | 70 | 76.2 | 61.4 | 114.1 | 4.56 | 4.89 | 66.1 | 62.7 | 108.3 | 4.30 | 10.1 | 5.20 |
| | | | | 80 | 73.2 | 57.8 | 122.4 | 4.79 | 4.48 | 62.9 | 58.9 | 116.4 | 4.51 | 10.3 | 4.75 |
| | 13.0 | 5.2 | 12.0 | 60 | 81.7 | 67.4 | 107.3 | 4.40 | 5.44 | 71.5 | 68.9 | 101.4 | 4.13 | 10.2 | 5.80 |
| | | | | 70 | 78.6 | 63.6 | 115.5 | 4.63 | 4.98 | 68.2 | 65.1 | 109.5 | 4.35 | 10.4 | 5.29 |
| | | | | 80 | 75.5 | 59.8 | 123.7 | 4.86 | 4.55 | 64.9 | 61.1 | 117.6 | 4.57 | 10.6 | 4.84 |

Notes:

1. Capacity data includes water pumping watts and are base upon 15% (by volume) propylene glycol antifreeze solution.
2. Desuperheater Capacity is based upon 0.4 GPM Flow per nominal ton at 90°F entering hot water temperature.
3. The manufacturer reserves the right to make changes in design and construction at any time without notice.
4. Extrapolation data down to 25°F for heating and interpolation between CFM, EWT & GPM data is permissible.
5. See Flow Rate Selection on page 7 for proper application.

GT096 Performance Data: 8.0 Ton, 3200 CFM, High Capacity Cooling

| EWT | GPM | WPD | | EAT DB/ WB | Cooling | | | | | Cooling with Desuperheater | | | | | |
|-----|------|-----|------|------------------|---------|------|-------|-------|------|----------------------------|------|-------|-------|------|------|
| | | PSI | FT | | TC | SC | HR | KW | EER | TC | SC | HR | KW | DH | EER |
| 50 | 14.5 | 2.1 | 4.8 | 75/63 | 96.2 | 67.2 | 113.3 | 5.88 | 16.4 | 96.2 | 67.4 | 113.3 | 5.77 | 8.1 | 16.7 |
| | | | | 80/67 | 104.5 | 70.0 | 120.6 | 6.02 | 17.4 | 104.5 | 70.1 | 120.4 | 5.89 | 8.3 | 17.6 |
| | | | | 85/71 | 112.9 | 72.8 | 127.7 | 6.14 | 18.4 | 112.9 | 72.9 | 127.8 | 6.01 | 8.5 | 18.8 |
| | 20.2 | 3.7 | 8.6 | 75/63 | 97.2 | 67.8 | 113.7 | 5.62 | 17.3 | 97.2 | 68.0 | 113.7 | 5.55 | 7.7 | 17.5 |
| | | | | 80/67 | 105.5 | 70.6 | 120.8 | 5.74 | 18.4 | 105.5 | 70.7 | 121.0 | 5.67 | 7.9 | 18.6 |
| | | | | 85/71 | 114.0 | 73.4 | 128.1 | 5.85 | 19.5 | 114.0 | 73.5 | 128.2 | 5.78 | 8.1 | 19.7 |
| | 26.0 | 6.0 | 14.0 | 75/63 | 98.2 | 67.8 | 114.2 | 5.46 | 18.0 | 98.2 | 68.0 | 114.3 | 5.43 | 7.3 | 18.1 |
| | | | | 80/67 | 106.7 | 70.6 | 121.6 | 5.57 | 19.2 | 106.7 | 70.7 | 121.6 | 5.54 | 7.5 | 19.2 |
| | | | | 85/71 | 115.2 | 73.4 | 128.7 | 5.69 | 20.3 | 115.2 | 73.5 | 129.0 | 5.64 | 7.7 | 20.4 |
| 70 | 14.5 | 2.0 | 4.7 | 75/63 | 90.2 | 66.0 | 110.3 | 7.08 | 12.8 | 90.8 | 66.2 | 110.5 | 6.91 | 11.7 | 13.1 |
| | | | | 80/67 | 98.0 | 68.6 | 117.2 | 7.24 | 13.5 | 98.6 | 68.9 | 117.4 | 7.04 | 12.1 | 14.0 |
| | | | | 85/71 | 105.9 | 71.4 | 124.4 | 7.36 | 14.4 | 106.5 | 71.7 | 124.6 | 7.20 | 12.4 | 14.8 |
| | 20.2 | 3.6 | 8.3 | 75/63 | 91.6 | 66.6 | 110.7 | 6.73 | 13.6 | 92.2 | 67.0 | 111.1 | 6.62 | 11.3 | 13.9 |
| | | | | 80/67 | 99.6 | 69.4 | 117.8 | 6.88 | 14.5 | 100.1 | 69.7 | 118.2 | 6.77 | 11.7 | 14.8 |
| | | | | 85/71 | 107.5 | 72.2 | 125.0 | 7.01 | 15.3 | 108.1 | 72.5 | 125.4 | 6.88 | 11.9 | 15.7 |
| | 26.0 | 5.8 | 13.3 | 75/63 | 92.4 | 66.6 | 111.3 | 6.53 | 14.2 | 93.0 | 67.0 | 111.7 | 6.49 | 10.7 | 14.3 |
| | | | | 80/67 | 100.6 | 69.4 | 118.4 | 6.66 | 15.1 | 101.1 | 69.7 | 118.8 | 6.63 | 11.1 | 15.3 |
| | | | | 85/71 | 108.5 | 72.2 | 125.4 | 6.80 | 16.0 | 109.1 | 72.5 | 126.0 | 6.74 | 11.5 | 16.2 |
| 90 | 14.5 | 1.9 | 4.3 | 75/63 | 82.1 | 63.3 | 106.1 | 8.75 | 9.4 | 82.9 | 63.8 | 106.5 | 8.48 | 15.4 | 9.8 |
| | | | | 80/67 | 89.3 | 65.9 | 112.9 | 8.91 | 10.0 | 90.1 | 66.4 | 113.3 | 8.66 | 15.8 | 10.4 |
| | | | | 85/71 | 96.4 | 68.6 | 119.8 | 9.06 | 10.6 | 97.3 | 68.9 | 120.2 | 8.82 | 16.2 | 11.0 |
| | 20.2 | 3.3 | 7.7 | 75/63 | 83.7 | 63.9 | 106.7 | 8.23 | 10.2 | 84.5 | 64.4 | 107.3 | 8.06 | 14.8 | 10.5 |
| | | | | 80/67 | 91.0 | 66.6 | 113.5 | 8.43 | 10.8 | 91.9 | 67.0 | 114.1 | 8.22 | 15.2 | 11.2 |
| | | | | 85/71 | 98.4 | 69.2 | 120.2 | 8.55 | 11.5 | 99.3 | 69.7 | 121.0 | 8.41 | 15.6 | 11.8 |
| | 26.0 | 5.4 | 12.4 | 75/63 | 84.7 | 63.9 | 106.9 | 8.02 | 10.6 | 85.5 | 64.4 | 107.7 | 7.92 | 14.2 | 10.8 |
| | | | | 80/67 | 92.0 | 66.6 | 113.7 | 8.17 | 11.3 | 92.9 | 67.0 | 114.7 | 8.08 | 14.6 | 11.5 |
| | | | | 85/71 | 99.4 | 69.2 | 120.6 | 8.36 | 11.9 | 100.3 | 69.7 | 121.6 | 8.22 | 15.0 | 12.2 |
| 110 | 14.5 | 1.8 | 4.2 | 75/63 | 71.6 | 59.3 | 101.0 | 10.90 | 6.6 | 72.8 | 59.8 | 101.3 | 10.58 | 19.0 | 6.9 |
| | | | | 80/67 | 77.8 | 61.7 | 107.5 | 11.04 | 7.0 | 79.1 | 62.2 | 107.9 | 10.75 | 19.6 | 7.4 |
| | | | | 85/71 | 84.1 | 64.1 | 113.9 | 11.31 | 7.4 | 85.5 | 64.8 | 114.3 | 10.93 | 20.2 | 7.8 |
| | 20.2 | 3.3 | 7.7 | 75/63 | 73.4 | 59.9 | 101.4 | 10.20 | 7.2 | 74.6 | 60.4 | 101.9 | 10.04 | 18.4 | 7.4 |
| | | | | 80/67 | 79.9 | 62.3 | 107.7 | 10.43 | 7.7 | 81.3 | 62.8 | 108.5 | 10.19 | 19.0 | 8.0 |
| | | | | 85/71 | 86.3 | 64.9 | 114.2 | 10.71 | 8.1 | 87.7 | 65.4 | 115.0 | 10.38 | 19.4 | 8.5 |
| | 26.0 | 5.3 | 12.1 | 75/63 | 74.2 | 59.9 | 101.4 | 9.98 | 7.4 | 75.4 | 60.4 | 102.3 | 9.84 | 17.6 | 7.7 |
| | | | | 80/67 | 80.7 | 62.3 | 107.7 | 10.12 | 8.0 | 82.1 | 62.8 | 108.9 | 10.09 | 18.2 | 8.1 |
| | | | | 85/71 | 87.1 | 64.9 | 114.2 | 10.30 | 8.4 | 88.5 | 65.4 | 115.4 | 10.20 | 18.8 | 8.7 |

Notes:

1. Capacity data includes water pumping watts and are base upon 15% (by volume) propylene glycol antifreeze solution.
2. Desuperheater Capacity is based upon 0.4 GPM Flow per nominal ton at 90°F entering hot water temperature.
3. The manufacturer reserves the right to make changes in design and construction at any time without notice.
4. Extrapolation data down to 25°F for heating and interpolation between CFM, EWT & GPM data is permissible.
5. See Flow Rate Selection on page 7 for proper application.

GT096 Performance Data: 8.0 Ton, 1600 CFM, Low Capacity Cooling

| EWT | GPM | WPD | | EAT DB/ WB | Cooling | | | | | Cooling with Desuperheater | | | | | |
|-----|------|-----|------|------------------|---------|------|------|------|------|----------------------------|------|------|------|------|------|
| | | PSI | FT | | TC | SC | HR | KW | EER | TC | SC | HR | KW | DH | EER |
| 50 | 7.2 | 2.0 | 4.7 | 75/63 | 48.1 | 33.6 | 56.6 | 2.96 | 16.2 | 48.1 | 33.7 | 56.6 | 2.91 | 4.0 | 16.6 |
| | | | | 80/67 | 52.3 | 35.0 | 60.3 | 3.03 | 17.3 | 52.3 | 35.1 | 60.2 | 2.96 | 4.1 | 17.6 |
| | | | | 85/71 | 56.4 | 36.4 | 63.9 | 3.09 | 18.3 | 56.4 | 36.5 | 63.9 | 3.03 | 4.2 | 18.7 |
| | 10.1 | 3.6 | 8.4 | 75/63 | 48.6 | 33.9 | 56.8 | 2.83 | 17.2 | 48.6 | 34.0 | 56.8 | 2.79 | 3.9 | 17.4 |
| | | | | 80/67 | 52.8 | 35.3 | 60.4 | 2.89 | 18.3 | 52.8 | 35.4 | 60.5 | 2.85 | 4.0 | 18.5 |
| | | | | 85/71 | 57.0 | 36.7 | 64.1 | 2.95 | 19.4 | 57.0 | 36.8 | 64.1 | 2.91 | 4.0 | 19.6 |
| | 13.0 | 5.9 | 13.6 | 75/63 | 49.1 | 33.9 | 57.1 | 2.75 | 17.9 | 49.1 | 34.0 | 57.1 | 2.73 | 3.7 | 18.0 |
| | | | | 80/67 | 53.4 | 35.3 | 60.8 | 2.80 | 19.0 | 53.4 | 35.4 | 60.8 | 2.79 | 3.8 | 19.1 |
| | | | | 85/71 | 57.6 | 36.7 | 64.4 | 2.86 | 20.1 | 57.6 | 36.8 | 64.5 | 2.84 | 3.9 | 20.3 |
| 70 | 7.2 | 2.0 | 4.5 | 75/63 | 45.1 | 33.0 | 55.1 | 3.56 | 12.7 | 45.4 | 33.1 | 55.2 | 3.48 | 5.8 | 13.1 |
| | | | | 80/67 | 49.0 | 34.3 | 58.6 | 3.64 | 13.4 | 49.3 | 34.5 | 68.7 | 3.54 | 6.0 | 13.9 |
| | | | | 85/71 | 53.0 | 35.7 | 62.2 | 3.70 | 14.3 | 53.3 | 35.9 | 62.3 | 3.63 | 6.2 | 14.7 |
| | 10.1 | 3.5 | 8.1 | 75/63 | 45.8 | 33.3 | 55.3 | 3.39 | 13.5 | 46.1 | 33.5 | 55.5 | 3.33 | 5.6 | 13.8 |
| | | | | 80/67 | 49.8 | 34.7 | 58.9 | 3.46 | 14.4 | 50.1 | 34.9 | 59.1 | 3.41 | 5.8 | 14.7 |
| | | | | 85/71 | 53.8 | 36.1 | 62.5 | 3.53 | 15.2 | 54.1 | 36.3 | 62.7 | 3.46 | 5.9 | 15.6 |
| | 13.0 | 5.6 | 12.9 | 75/63 | 46.2 | 33.3 | 55.6 | 3.29 | 14.1 | 46.5 | 33.5 | 55.8 | 3.27 | 5.3 | 14.2 |
| | | | | 80/67 | 50.3 | 34.7 | 59.2 | 3.35 | 15.0 | 50.6 | 34.9 | 59.4 | 3.34 | 5.5 | 15.2 |
| | | | | 85/71 | 54.2 | 36.1 | 62.7 | 3.42 | 15.9 | 54.6 | 36.3 | 63.0 | 3.39 | 5.7 | 16.1 |
| 90 | 7.2 | 1.8 | 4.2 | 75/63 | 41.1 | 31.6 | 53.1 | 4.40 | 9.3 | 41.5 | 31.9 | 53.3 | 4.27 | 7.7 | 9.7 |
| | | | | 80/67 | 44.6 | 32.9 | 56.4 | 4.49 | 9.9 | 45.1 | 33.2 | 56.6 | 4.36 | 7.9 | 10.3 |
| | | | | 85/71 | 48.2 | 34.3 | 59.9 | 4.56 | 10.6 | 48.7 | 34.5 | 60.1 | 4.44 | 8.1 | 11.0 |
| | 10.1 | 3.3 | 7.5 | 75/63 | 41.9 | 31.9 | 53.4 | 4.14 | 10.1 | 42.3 | 32.2 | 53.6 | 4.06 | 7.4 | 10.4 |
| | | | | 80/67 | 45.5 | 33.3 | 56.7 | 4.24 | 10.7 | 46.0 | 33.5 | 57.0 | 4.13 | 7.6 | 11.1 |
| | | | | 85/71 | 49.2 | 34.6 | 60.1 | 4.31 | 11.4 | 49.7 | 34.9 | 60.5 | 4.23 | 7.8 | 11.7 |
| | 13.0 | 5.2 | 12.0 | 75/63 | 42.3 | 31.9 | 53.5 | 4.04 | 10.5 | 42.8 | 32.2 | 53.8 | 3.99 | 7.1 | 10.7 |
| | | | | 80/67 | 46.0 | 33.3 | 56.8 | 4.11 | 11.2 | 46.5 | 33.5 | 57.3 | 4.07 | 7.3 | 11.4 |
| | | | | 85/71 | 49.7 | 34.6 | 60.3 | 4.21 | 11.8 | 50.2 | 34.9 | 60.8 | 4.14 | 7.5 | 12.1 |
| 110 | 7.2 | 1.8 | 4.0 | 75/63 | 35.8 | 29.7 | 50.5 | 5.48 | 6.5 | 36.4 | 29.9 | 50.7 | 5.32 | 9.5 | 6.8 |
| | | | | 80/67 | 38.9 | 30.8 | 53.8 | 5.56 | 7.0 | 39.5 | 31.1 | 53.9 | 5.41 | 9.8 | 7.3 |
| | | | | 85/71 | 42.0 | 32.0 | 56.9 | 5.70 | 7.4 | 42.8 | 32.4 | 57.1 | 5.50 | 10.1 | 7.8 |
| | 10.1 | 3.2 | 7.4 | 75/63 | 36.7 | 30.0 | 50.7 | 5.13 | 7.2 | 37.3 | 30.2 | 51.0 | 5.05 | 9.2 | 7.4 |
| | | | | 80/67 | 40.0 | 31.1 | 53.9 | 5.25 | 7.6 | 40.6 | 31.4 | 54.2 | 5.13 | 9.5 | 7.9 |
| | | | | 85/71 | 43.1 | 32.4 | 57.1 | 5.39 | 8.0 | 43.9 | 32.7 | 57.5 | 5.23 | 9.7 | 8.4 |
| | 13.0 | 5.1 | 11.8 | 75/63 | 37.1 | 30.0 | 50.7 | 5.02 | 7.4 | 37.7 | 30.2 | 51.2 | 4.95 | 8.8 | 7.6 |
| | | | | 80/67 | 40.4 | 31.1 | 53.9 | 5.09 | 7.9 | 41.0 | 31.4 | 54.4 | 5.08 | 9.1 | 8.1 |
| | | | | 85/71 | 43.5 | 32.4 | 57.1 | 5.19 | 8.4 | 44.3 | 32.7 | 57.7 | 5.13 | 9.4 | 8.6 |

Notes:

- Capacity data includes water pumping watts and are base upon 15% (by volume) propylene glycol antifreeze solution.
- Desuperheater Capacity is based upon 0.4 GPM Flow per nominal ton at 90°F entering hot water temperature.
- The manufacturer reserves the right to make changes in design and construction at any time without notice.
- Extrapolation data down to 25°F for heating and interpolation between CFM, EWT & GPM data is permissible.
- See Flow Rate Selection on page 7 for proper application.

GT120 Performance Data: 10.0 Ton, 4000 CFM, High Capacity Heating

| EWT | GPM | WPD | | Heating | | | | | | Heating with Desuperheater | | | | | |
|-----|------|-----|------|---------|-------|-------|-------|-------|------|----------------------------|-------|-------|-------|------|------|
| | | PSI | FT | EAT | HC | HE | LAT | KW | COP | HC | HE | LAT | KW | DH | COP |
| 30 | 15.6 | 2.3 | 5.3 | 60 | 94.6 | 67.9 | 81.9 | 7.96 | 3.48 | 82.8 | 68.0 | 79.2 | 7.87 | 11.8 | 3.52 |
| | | | | 70 | 91.9 | 63.9 | 91.3 | 8.39 | 3.21 | 79.7 | 64.3 | 88.5 | 8.24 | 12.1 | 3.27 |
| | | | | 80 | 89.0 | 60.2 | 100.6 | 8.79 | 2.97 | 76.5 | 60.3 | 97.7 | 8.62 | 12.5 | 3.03 |
| | 21.8 | 4.3 | 9.8 | 60 | 97.4 | 70.8 | 82.6 | 8.05 | 3.55 | 85.3 | 70.9 | 79.7 | 7.87 | 12.1 | 3.63 |
| | | | | 70 | 94.7 | 66.5 | 91.9 | 8.48 | 3.28 | 82.2 | 66.9 | 89.0 | 8.30 | 12.5 | 3.35 |
| | | | | 80 | 92.2 | 62.6 | 101.3 | 8.90 | 3.03 | 79.2 | 62.9 | 98.3 | 8.70 | 12.9 | 3.10 |
| | 28.0 | 6.8 | 15.8 | 60 | 98.7 | 72.1 | 82.8 | 8.04 | 3.60 | 86.4 | 72.5 | 80.0 | 7.87 | 12.3 | 3.68 |
| | | | | 70 | 96.1 | 68.1 | 92.2 | 8.47 | 3.33 | 83.4 | 58.6 | 89.3 | 8.30 | 12.7 | 3.39 |
| | | | | 80 | 93.5 | 63.9 | 101.6 | 8.89 | 3.08 | 80.4 | 64.3 | 98.6 | 8.72 | 13.1 | 3.14 |
| 50 | 15.6 | 2.1 | 4.9 | 60 | 122.3 | 94.8 | 88.3 | 8.34 | 4.30 | 107.1 | 95.6 | 84.8 | 8.07 | 15.2 | 4.45 |
| | | | | 70 | 118.7 | 89.2 | 97.5 | 8.79 | 3.96 | 103.0 | 90.0 | 93.8 | 8.51 | 15.7 | 4.09 |
| | | | | 80 | 114.6 | 84.0 | 106.5 | 9.22 | 3.65 | 98.5 | 84.7 | 102.8 | 8.95 | 16.1 | 3.75 |
| | 21.8 | 4.0 | 9.1 | 60 | 127.5 | 99.3 | 89.5 | 8.50 | 4.39 | 111.6 | 100.4 | 85.8 | 8.23 | 15.9 | 4.54 |
| | | | | 70 | 123.3 | 93.7 | 98.5 | 8.96 | 4.03 | 107.0 | 94.6 | 94.8 | 8.66 | 16.3 | 4.17 |
| | | | | 80 | 119.3 | 87.9 | 107.6 | 9.42 | 3.71 | 102.6 | 89.0 | 103.7 | 9.10 | 16.8 | 3.84 |
| | 28.0 | 6.4 | 14.7 | 60 | 130.1 | 101.9 | 90.1 | 8.54 | 4.46 | 113.9 | 102.8 | 86.4 | 8.24 | 16.2 | 4.63 |
| | | | | 70 | 125.9 | 96.1 | 99.1 | 9.00 | 4.10 | 109.3 | 97.2 | 95.3 | 8.70 | 16.6 | 4.24 |
| | | | | 80 | 121.7 | 90.3 | 108.2 | 9.45 | 3.77 | 104.6 | 91.4 | 104.2 | 9.14 | 17.1 | 3.90 |
| 70 | 15.6 | 2.1 | 4.9 | 60 | 148.8 | 119.6 | 94.5 | 8.87 | 4.92 | 130.3 | 121.1 | 90.2 | 8.46 | 18.5 | 5.16 |
| | | | | 70 | 143.6 | 112.7 | 103.2 | 9.33 | 4.51 | 124.6 | 114.2 | 98.8 | 8.92 | 19.0 | 4.72 |
| | | | | 80 | 138.3 | 105.9 | 112.0 | 9.78 | 4.14 | 118.9 | 107.6 | 107.5 | 9.36 | 19.4 | 4.33 |
| | 21.8 | 3.8 | 8.8 | 60 | 156.3 | 125.9 | 96.2 | 9.13 | 5.02 | 136.8 | 128.0 | 91.7 | 8.71 | 19.5 | 5.26 |
| | | | | 70 | 150.7 | 118.8 | 104.9 | 9.61 | 4.60 | 130.8 | 120.6 | 100.3 | 9.18 | 19.9 | 4.81 |
| | | | | 80 | 145.2 | 111.6 | 113.6 | 10.11 | 4.21 | 124.8 | 113.4 | 108.9 | 9.64 | 20.4 | 4.42 |
| | 28.0 | 6.1 | 14.0 | 60 | 160.5 | 129.9 | 97.2 | 9.23 | 5.09 | 140.5 | 132.0 | 92.5 | 8.78 | 20.0 | 5.36 |
| | | | | 70 | 154.7 | 122.5 | 105.8 | 9.72 | 4.67 | 134.3 | 124.6 | 101.1 | 9.25 | 20.5 | 4.90 |
| | | | | 80 | 148.9 | 115.1 | 114.5 | 10.20 | 4.28 | 128.0 | 117.1 | 109.6 | 9.71 | 20.9 | 4.49 |
| 90 | 15.6 | 2.0 | 4.6 | 60 | 171.6 | 141.0 | 99.7 | 8.80 | 5.72 | 150.2 | 143.7 | 94.8 | 8.75 | 21.4 | 5.75 |
| | | | | 70 | 165.3 | 132.8 | 108.3 | 9.95 | 4.87 | 143.4 | 135.5 | 103.2 | 9.22 | 21.8 | 5.25 |
| | | | | 80 | 158.9 | 124.9 | 116.8 | 10.24 | 4.55 | 136.6 | 127.2 | 111.6 | 9.69 | 22.3 | 4.80 |
| | 21.8 | 3.5 | 8.1 | 60 | 181.4 | 149.4 | 102.0 | 9.66 | 5.50 | 158.8 | 152.5 | 96.8 | 9.08 | 22.6 | 5.86 |
| | | | | 70 | 174.8 | 141.0 | 110.5 | 10.17 | 5.04 | 151.7 | 144.0 | 105.1 | 9.58 | 23.1 | 5.35 |
| | | | | 80 | 167.9 | 132.5 | 118.9 | 10.68 | 4.61 | 144.3 | 135.2 | 113.4 | 10.06 | 23.6 | 4.89 |
| | 28.0 | 5.6 | 13.0 | 60 | 187.4 | 154.7 | 103.4 | 9.81 | 5.60 | 164.1 | 158.0 | 98.0 | 9.20 | 23.3 | 5.97 |
| | | | | 70 | 180.3 | 146.0 | 111.7 | 10.31 | 5.12 | 156.5 | 149.3 | 106.2 | 9.70 | 23.8 | 5.45 |
| | | | | 80 | 173.2 | 137.3 | 120.1 | 10.83 | 4.69 | 148.9 | 140.2 | 114.5 | 10.19 | 24.3 | 4.98 |

Notes:

1. Capacity data includes water pumping watts and are base upon 15% (by volume) propylene glycol antifreeze solution.
2. Desuperheater Capacity is based upon 0.4 GPM Flow per nominal ton at 90°F entering hot water temperature.
3. The manufacturer reserves the right to make changes in design and construction at any time without notice.
4. Extrapolation data down to 25°F for heating and interpolation between CFM, EWT & GPM data is permissible.
5. See Flow Rate Selection on page 7 for proper application.

GT120 Performance Data: 10.0 Ton, 2000 CFM, Low Capacity Heating

| EWT | GPM | WPD | | Heating | | | | | | Heating with Desuperheater | | | | | |
|-----|------|-----|------|---------|------|------|-------|------|------|----------------------------|------|-------|------|------|------|
| | | PSI | FT | EAT | HC | HE | LAT | KW | COP | HC | HE | LAT | KW | DH | COP |
| 30 | 8.3 | 2.2 | 5.0 | 60 | 47.3 | 33.9 | 81.9 | 4.10 | 3.38 | 41.4 | 34.0 | 79.2 | 4.05 | 5.9 | 3.42 |
| | | | | 70 | 45.9 | 31.9 | 91.3 | 4.32 | 3.12 | 39.8 | 32.1 | 88.4 | 4.24 | 6.1 | 3.17 |
| | | | | 80 | 44.5 | 30.1 | 100.6 | 4.52 | 2.88 | 38.2 | 30.1 | 97.7 | 4.44 | 6.2 | 2.94 |
| | 11.7 | 4.0 | 9.3 | 60 | 48.7 | 35.4 | 82.5 | 4.14 | 3.45 | 42.6 | 35.4 | 79.7 | 4.05 | 6.1 | 3.52 |
| | | | | 70 | 47.4 | 33.3 | 91.9 | 4.36 | 3.18 | 41.1 | 33.5 | 89.0 | 4.27 | 6.3 | 3.25 |
| | | | | 80 | 46.1 | 31.3 | 101.3 | 4.58 | 2.95 | 39.6 | 31.5 | 98.3 | 4.48 | 6.5 | 3.01 |
| | 15.0 | 6.5 | 15.0 | 60 | 49.3 | 36.0 | 82.8 | 4.14 | 3.49 | 43.2 | 36.2 | 80.0 | 4.05 | 6.1 | 3.57 |
| | | | | 70 | 48.0 | 34.0 | 92.2 | 4.36 | 3.23 | 41.7 | 29.3 | 89.3 | 4.27 | 6.3 | 3.30 |
| | | | | 80 | 46.7 | 31.9 | 101.6 | 4.57 | 2.99 | 40.2 | 32.1 | 98.6 | 4.49 | 6.6 | 3.05 |
| 50 | 8.3 | 2.0 | 4.7 | 60 | 61.1 | 47.4 | 88.3 | 4.29 | 4.17 | 53.5 | 47.8 | 84.8 | 4.15 | 7.6 | 4.32 |
| | | | | 70 | 59.3 | 44.6 | 97.5 | 4.52 | 3.84 | 51.5 | 45.0 | 93.8 | 4.38 | 7.8 | 3.97 |
| | | | | 80 | 57.3 | 42.0 | 106.5 | 4.74 | 3.54 | 49.2 | 42.3 | 102.8 | 4.60 | 8.0 | 3.65 |
| | 11.7 | 3.7 | 8.6 | 60 | 63.7 | 49.6 | 89.5 | 4.38 | 4.27 | 55.8 | 50.2 | 85.8 | 4.23 | 7.9 | 4.41 |
| | | | | 70 | 61.6 | 46.8 | 98.5 | 4.61 | 3.92 | 53.5 | 47.3 | 94.8 | 4.46 | 8.1 | 4.05 |
| | | | | 80 | 59.6 | 43.9 | 107.6 | 4.84 | 3.61 | 51.3 | 44.5 | 103.7 | 4.68 | 8.4 | 3.73 |
| | 15.0 | 6.0 | 14.0 | 60 | 65.0 | 50.9 | 90.1 | 4.40 | 4.34 | 56.9 | 51.4 | 86.4 | 4.24 | 8.1 | 4.50 |
| | | | | 70 | 62.9 | 48.0 | 99.1 | 4.63 | 3.99 | 54.6 | 48.6 | 95.3 | 4.48 | 8.3 | 4.12 |
| | | | | 80 | 60.8 | 45.1 | 108.1 | 4.86 | 3.66 | 52.3 | 45.7 | 104.2 | 4.70 | 8.5 | 3.79 |
| 70 | 8.3 | 2.0 | 4.7 | 60 | 74.4 | 59.8 | 94.4 | 4.56 | 4.78 | 65.1 | 60.5 | 90.2 | 4.35 | 9.3 | 5.01 |
| | | | | 70 | 71.7 | 56.3 | 103.2 | 4.80 | 4.38 | 62.3 | 57.1 | 98.8 | 4.59 | 9.5 | 4.58 |
| | | | | 80 | 69.1 | 52.9 | 112.0 | 5.03 | 4.02 | 59.4 | 53.8 | 107.5 | 4.82 | 9.7 | 4.20 |
| | 11.7 | 3.6 | 8.3 | 60 | 78.1 | 62.9 | 96.2 | 4.70 | 4.87 | 68.4 | 64.0 | 91.7 | 4.48 | 9.7 | 5.11 |
| | | | | 70 | 75.3 | 59.4 | 104.9 | 4.94 | 4.47 | 65.4 | 60.3 | 100.3 | 4.72 | 10.0 | 4.68 |
| | | | | 80 | 72.6 | 55.8 | 113.6 | 5.20 | 4.09 | 62.4 | 56.7 | 108.9 | 4.96 | 10.2 | 4.29 |
| | 15.0 | 5.8 | 13.3 | 60 | 80.2 | 64.9 | 97.1 | 4.75 | 4.95 | 70.2 | 66.0 | 92.5 | 4.52 | 10.0 | 5.21 |
| | | | | 70 | 77.3 | 61.2 | 105.8 | 5.00 | 4.53 | 67.1 | 62.3 | 101.1 | 4.76 | 10.2 | 4.76 |
| | | | | 80 | 74.4 | 57.5 | 114.5 | 5.25 | 4.16 | 64.0 | 58.5 | 109.6 | 5.00 | 10.4 | 4.37 |
| 90 | 8.3 | 1.9 | 4.3 | 60 | 85.8 | 70.5 | 99.7 | 4.53 | 5.55 | 75.1 | 71.8 | 94.8 | 4.50 | 10.7 | 5.58 |
| | | | | 70 | 82.6 | 66.4 | 108.2 | 5.12 | 4.73 | 71.7 | 67.7 | 103.2 | 4.74 | 10.9 | 5.10 |
| | | | | 80 | 79.4 | 62.4 | 116.8 | 5.27 | 4.42 | 68.3 | 63.6 | 111.6 | 4.99 | 11.2 | 4.67 |
| | 11.7 | 3.3 | 7.7 | 60 | 90.6 | 74.7 | 102.0 | 4.97 | 5.35 | 79.4 | 76.2 | 96.7 | 4.67 | 11.3 | 5.69 |
| | | | | 70 | 87.3 | 70.5 | 110.4 | 5.23 | 4.89 | 75.8 | 71.9 | 105.1 | 4.93 | 11.5 | 5.20 |
| | | | | 80 | 83.9 | 66.2 | 118.9 | 5.49 | 4.48 | 72.1 | 67.6 | 113.4 | 5.17 | 11.8 | 4.75 |
| | 15.0 | 5.3 | 12.3 | 60 | 93.7 | 77.3 | 103.4 | 5.05 | 5.44 | 82.0 | 79.0 | 98.0 | 4.73 | 11.7 | 5.80 |
| | | | | 70 | 90.1 | 73.0 | 111.7 | 5.31 | 4.98 | 78.2 | 74.6 | 106.2 | 4.99 | 11.9 | 5.29 |
| | | | | 80 | 86.6 | 68.6 | 120.1 | 5.57 | 4.55 | 74.4 | 70.1 | 114.4 | 5.24 | 12.2 | 4.84 |

Notes:

1. Capacity data includes water pumping watts and are base upon 15% (by volume) propylene glycol antifreeze solution.
2. Desuperheater Capacity is based upon 0.4 GPM Flow per nominal ton at 90°F entering hot water temperature.
3. The manufacturer reserves the right to make changes in design and construction at any time without notice.
4. Extrapolation data down to 25°F for heating and interpolation between CFM, EWT & GPM data is permissible.
5. See Flow Rate Selection on page 7 for proper application.

GT120 Performance Data: 10.0 Ton, 4000 CFM, High Capacity Cooling

| EWT | GPM | WPD | | EAT DB/ WB | Cooling | | | | | Cooling with Desuperheater | | | | | |
|-----|------|-----|------|------------------|---------|------|-------|-------|------|----------------------------|------|-------|-------|------|------|
| | | PSI | FT | | TC | SC | HR | KW | EER | TC | SC | HR | KW | DH | EER |
| 50 | 15.6 | 2.2 | 5.1 | 75/63 | 123.8 | 86.5 | 145.7 | 7.57 | 16.4 | 123.8 | 86.7 | 145.7 | 7.43 | 10.4 | 16.7 |
| | | | | 80/67 | 134.5 | 90.1 | 155.2 | 7.74 | 17.4 | 134.5 | 90.2 | 154.9 | 7.57 | 10.7 | 17.8 |
| | | | | 85/71 | 145.2 | 93.7 | 164.4 | 7.90 | 18.4 | 145.2 | 93.8 | 164.4 | 7.73 | 10.9 | 18.8 |
| | 21.8 | 4.0 | 9.1 | 75/63 | 125.1 | 87.3 | 146.2 | 7.23 | 17.3 | 125.1 | 87.4 | 146.2 | 7.14 | 9.9 | 17.5 |
| | | | | 80/67 | 135.8 | 90.9 | 155.4 | 7.38 | 18.4 | 135.8 | 91.0 | 155.7 | 7.29 | 10.2 | 18.6 |
| | | | | 85/71 | 146.7 | 94.4 | 164.9 | 7.53 | 19.5 | 146.7 | 94.6 | 164.9 | 7.44 | 10.4 | 19.7 |
| | 28.0 | 6.4 | 14.7 | 75/63 | 126.3 | 87.3 | 147.0 | 7.02 | 18.0 | 126.3 | 87.4 | 147.0 | 6.99 | 9.4 | 18.1 |
| | | | | 80/67 | 137.3 | 90.9 | 156.4 | 7.16 | 19.2 | 137.3 | 91.0 | 156.5 | 7.13 | 9.7 | 19.2 |
| | | | | 85/71 | 148.3 | 94.4 | 165.6 | 7.32 | 20.3 | 148.3 | 94.6 | 165.9 | 7.26 | 9.9 | 20.4 |
| 70 | 15.6 | 2.1 | 4.9 | 75/63 | 116.1 | 85.0 | 141.9 | 9.11 | 12.8 | 116.8 | 85.1 | 142.1 | 8.89 | 15.0 | 13.1 |
| | | | | 80/67 | 126.1 | 88.3 | 150.8 | 9.31 | 13.5 | 126.8 | 88.7 | 151.1 | 9.05 | 15.5 | 14.0 |
| | | | | 85/71 | 136.3 | 91.9 | 160.0 | 9.47 | 14.4 | 137.1 | 92.3 | 160.3 | 9.27 | 16.0 | 14.8 |
| | 21.8 | 3.8 | 8.8 | 75/63 | 117.9 | 85.7 | 142.4 | 8.66 | 13.6 | 118.6 | 86.2 | 142.9 | 8.52 | 15.5 | 13.9 |
| | | | | 80/67 | 128.1 | 89.3 | 151.6 | 8.85 | 14.5 | 128.9 | 89.7 | 152.1 | 8.71 | 15.0 | 14.8 |
| | | | | 85/71 | 138.3 | 92.9 | 160.8 | 9.02 | 15.3 | 139.1 | 93.3 | 161.3 | 8.85 | 15.3 | 15.7 |
| | 28.0 | 6.1 | 14.0 | 75/63 | 118.9 | 85.7 | 143.2 | 8.40 | 14.2 | 119.6 | 86.2 | 143.7 | 8.35 | 13.7 | 14.3 |
| | | | | 80/67 | 129.4 | 89.3 | 152.4 | 8.57 | 15.1 | 130.1 | 89.7 | 152.9 | 8.53 | 14.2 | 15.3 |
| | | | | 85/71 | 139.6 | 92.9 | 161.3 | 8.75 | 16.0 | 140.4 | 93.3 | 162.1 | 8.67 | 14.7 | 16.2 |
| 90 | 15.6 | 2.0 | 4.6 | 75/63 | 105.7 | 81.4 | 136.5 | 11.25 | 9.4 | 106.7 | 82.1 | 137.0 | 10.91 | 19.8 | 9.8 |
| | | | | 80/67 | 114.8 | 84.7 | 145.2 | 11.47 | 10.0 | 115.9 | 85.4 | 145.7 | 11.14 | 20.3 | 10.4 |
| | | | | 85/71 | 124.0 | 88.3 | 154.1 | 11.66 | 10.6 | 125.2 | 88.7 | 154.7 | 11.35 | 20.8 | 11.0 |
| | 21.8 | 3.5 | 8.2 | 75/63 | 107.7 | 82.2 | 137.3 | 10.59 | 10.2 | 108.7 | 82.8 | 138.1 | 10.37 | 19.1 | 10.5 |
| | | | | 80/67 | 117.1 | 85.7 | 146.0 | 10.85 | 10.8 | 118.3 | 86.2 | 146.8 | 10.57 | 19.6 | 11.2 |
| | | | | 85/71 | 126.6 | 89.1 | 154.7 | 11.01 | 11.5 | 127.8 | 89.7 | 155.7 | 10.82 | 20.1 | 11.8 |
| | 28.0 | 5.7 | 13.1 | 75/63 | 109.0 | 82.2 | 137.6 | 10.32 | 10.6 | 110.0 | 82.8 | 138.6 | 10.19 | 18.3 | 10.8 |
| | | | | 80/67 | 118.4 | 85.7 | 146.2 | 10.51 | 11.3 | 119.6 | 86.2 | 147.5 | 10.39 | 18.8 | 11.5 |
| | | | | 85/71 | 127.9 | 89.1 | 155.2 | 10.57 | 11.9 | 129.1 | 89.7 | 156.5 | 10.58 | 19.3 | 12.2 |
| 110 | 15.6 | 1.9 | 4.4 | 75/63 | 92.1 | 76.3 | 129.9 | 14.02 | 6.6 | 93.7 | 77.0 | 130.4 | 13.61 | 24.4 | 6.9 |
| | | | | 80/67 | 100.0 | 79.4 | 138.3 | 14.21 | 7.0 | 101.7 | 80.0 | 138.8 | 13.83 | 25.2 | 7.4 |
| | | | | 85/71 | 108.2 | 82.4 | 146.5 | 14.56 | 7.4 | 110.0 | 83.3 | 147.0 | 14.06 | 25.9 | 7.8 |
| | 21.8 | 3.5 | 8.1 | 75/63 | 94.4 | 77.1 | 130.4 | 13.12 | 7.2 | 96.0 | 77.7 | 131.2 | 12.92 | 23.6 | 7.4 |
| | | | | 80/67 | 102.8 | 80.1 | 138.6 | 13.41 | 7.7 | 104.6 | 80.8 | 139.6 | 13.11 | 24.4 | 8.0 |
| | | | | 85/71 | 111.0 | 83.5 | 147.0 | 13.78 | 8.1 | 112.9 | 84.1 | 148.0 | 13.36 | 24.9 | 8.5 |
| | 28.0 | 5.5 | 12.8 | 75/63 | 95.4 | 77.1 | 130.4 | 12.84 | 7.4 | 97.1 | 77.7 | 131.7 | 12.66 | 22.6 | 7.7 |
| | | | | 80/67 | 103.9 | 80.1 | 138.6 | 13.02 | 8.0 | 105.6 | 80.8 | 140.1 | 12.98 | 23.4 | 8.1 |
| | | | | 85/71 | 112.0 | 83.5 | 147.0 | 13.26 | 8.4 | 113.9 | 84.1 | 148.5 | 13.12 | 24.1 | 8.7 |

Notes:

1. Capacity data includes water pumping watts and are base upon 15% (by volume) propylene glycol antifreeze solution.
2. Desuperheater Capacity is based upon 0.4 GPM Flow per nominal ton at 90°F entering hot water temperature.
3. The manufacturer reserves the right to make changes in design and construction at any time without notice.
4. Extrapolation data down to 25°F for heating and interpolation between CFM, EWT & GPM data is permissible.
5. See Flow Rate Selection on page 7 for proper application.

GT120 Performance Data: 10.0 Ton, 2000 CFM, Low Capacity Cooling

| EWT | GPM | WPD | | EAT DB/ WB | Cooling | | | | | Cooling with Desuperheater | | | | | |
|-----|------|-----|------|------------------|---------|------|------|------|------|----------------------------|------|------|------|------|------|
| | | PSI | FT | | TC | SC | HR | KW | EER | TC | SC | HR | KW | DH | EER |
| 50 | 8.3 | 2.1 | 4.8 | 75/63 | 61.9 | 43.3 | 72.9 | 3.81 | 16.2 | 61.9 | 43.3 | 72.9 | 3.74 | 5.2 | 16.6 |
| | | | | 80/67 | 67.2 | 45.0 | 77.6 | 3.90 | 17.3 | 67.2 | 45.1 | 77.5 | 3.81 | 5.3 | 17.6 |
| | | | | 85/71 | 72.6 | 46.8 | 82.2 | 3.98 | 18.3 | 72.6 | 46.9 | 82.2 | 3.89 | 5.5 | 18.7 |
| | 11.7 | 3.7 | 8.6 | 75/63 | 62.5 | 43.6 | 73.1 | 3.64 | 17.2 | 62.5 | 43.7 | 73.1 | 3.59 | 5.0 | 17.4 |
| | | | | 80/67 | 67.9 | 45.4 | 77.7 | 3.72 | 18.3 | 67.9 | 45.5 | 77.8 | 3.67 | 5.1 | 18.5 |
| | | | | 85/71 | 73.4 | 47.2 | 82.4 | 3.79 | 19.4 | 73.4 | 47.3 | 82.5 | 3.75 | 5.2 | 19.6 |
| | 15.0 | 6.0 | 14.0 | 75/63 | 63.2 | 43.6 | 73.5 | 3.53 | 17.9 | 63.2 | 43.7 | 73.5 | 3.52 | 4.7 | 18.0 |
| | | | | 80/67 | 68.7 | 45.4 | 78.2 | 3.61 | 19.0 | 68.7 | 45.5 | 78.2 | 3.59 | 4.8 | 19.1 |
| | | | | 85/71 | 74.1 | 47.2 | 82.8 | 3.68 | 20.1 | 74.1 | 47.3 | 83.0 | 3.65 | 5.0 | 20.3 |
| 70 | 8.3 | 2.0 | 4.7 | 75/63 | 58.1 | 42.5 | 70.9 | 4.58 | 12.7 | 58.4 | 42.6 | 71.1 | 4.47 | 7.5 | 13.1 |
| | | | | 80/67 | 63.0 | 44.2 | 75.4 | 4.69 | 13.4 | 63.4 | 44.4 | 75.5 | 4.56 | 7.8 | 13.9 |
| | | | | 85/71 | 68.1 | 45.9 | 80.0 | 4.79 | 14.3 | 68.5 | 46.1 | 80.2 | 4.67 | 8.0 | 14.7 |
| | 11.7 | 3.6 | 8.3 | 75/63 | 59.0 | 42.9 | 71.2 | 4.36 | 13.5 | 59.3 | 43.1 | 71.5 | 4.29 | 7.2 | 13.8 |
| | | | | 80/67 | 64.1 | 44.7 | 75.8 | 4.46 | 14.4 | 64.4 | 44.9 | 76.1 | 4.39 | 7.5 | 14.7 |
| | | | | 85/71 | 69.2 | 46.4 | 80.4 | 4.54 | 15.2 | 69.6 | 46.7 | 80.7 | 4.45 | 7.6 | 15.6 |
| | 15.0 | 5.8 | 13.3 | 75/63 | 59.5 | 42.9 | 71.6 | 4.23 | 14.1 | 59.8 | 43.1 | 71.8 | 4.20 | 6.9 | 14.2 |
| | | | | 80/67 | 64.7 | 44.7 | 76.2 | 4.31 | 15.0 | 65.1 | 44.9 | 76.5 | 4.29 | 7.1 | 15.2 |
| | | | | 85/71 | 69.8 | 46.4 | 80.6 | 4.40 | 15.9 | 70.2 | 46.7 | 81.0 | 4.36 | 7.4 | 16.1 |
| 90 | 8.3 | 1.9 | 4.3 | 75/63 | 52.8 | 40.7 | 68.3 | 5.66 | 9.3 | 53.3 | 41.0 | 68.5 | 5.49 | 9.9 | 9.7 |
| | | | | 80/67 | 57.4 | 42.4 | 72.6 | 5.77 | 9.9 | 58.0 | 42.7 | 72.9 | 5.61 | 10.2 | 10.3 |
| | | | | 85/71 | 62.0 | 44.2 | 77.1 | 5.87 | 10.6 | 62.6 | 44.4 | 77.3 | 5.71 | 10.4 | 11.0 |
| | 11.7 | 3.3 | 7.7 | 75/63 | 53.8 | 41.1 | 68.7 | 5.33 | 10.1 | 54.4 | 41.4 | 69.0 | 5.22 | 9.5 | 10.4 |
| | | | | 80/67 | 58.6 | 42.9 | 73.0 | 5.46 | 10.7 | 59.1 | 43.1 | 73.4 | 5.32 | 9.8 | 11.1 |
| | | | | 85/71 | 63.3 | 44.5 | 77.3 | 5.54 | 11.4 | 63.9 | 44.9 | 77.8 | 5.44 | 10.0 | 11.7 |
| | 15.0 | 5.4 | 12.4 | 75/63 | 54.5 | 41.1 | 68.8 | 5.19 | 10.5 | 55.0 | 41.4 | 69.3 | 5.13 | 9.2 | 10.7 |
| | | | | 80/67 | 59.2 | 42.9 | 73.1 | 5.29 | 11.2 | 59.8 | 43.1 | 73.8 | 5.23 | 9.4 | 11.4 |
| | | | | 85/71 | 63.9 | 44.5 | 77.6 | 5.41 | 11.8 | 64.5 | 44.9 | 78.2 | 5.32 | 9.7 | 12.1 |
| 110 | 8.3 | 1.8 | 4.2 | 75/63 | 46.1 | 38.2 | 65.0 | 7.06 | 6.5 | 46.8 | 38.5 | 65.2 | 6.85 | 12.2 | 6.8 |
| | | | | 80/67 | 50.0 | 39.7 | 69.2 | 7.15 | 7.0 | 50.9 | 40.0 | 69.4 | 6.96 | 12.6 | 7.3 |
| | | | | 85/71 | 54.1 | 41.2 | 73.2 | 7.33 | 7.4 | 55.0 | 41.7 | 73.5 | 7.08 | 13.0 | 7.8 |
| | 11.7 | 3.3 | 7.7 | 75/63 | 47.2 | 38.5 | 65.2 | 6.60 | 7.2 | 48.0 | 38.9 | 65.6 | 6.50 | 11.8 | 7.4 |
| | | | | 80/67 | 51.4 | 40.1 | 69.3 | 6.75 | 7.6 | 52.3 | 40.4 | 69.8 | 6.60 | 12.2 | 7.9 |
| | | | | 85/71 | 55.5 | 41.7 | 73.5 | 6.93 | 8.0 | 56.4 | 42.1 | 74.0 | 6.72 | 12.5 | 8.4 |
| | 15.0 | 5.3 | 12.1 | 75/63 | 47.7 | 38.5 | 65.2 | 6.46 | 7.4 | 48.5 | 38.9 | 65.8 | 6.37 | 11.3 | 7.6 |
| | | | | 80/67 | 51.9 | 40.1 | 69.3 | 6.55 | 7.9 | 52.8 | 40.4 | 70.1 | 6.53 | 11.7 | 8.1 |
| | | | | 85/71 | 56.0 | 41.7 | 73.5 | 6.67 | 8.4 | 57.0 | 42.1 | 74.3 | 6.60 | 12.1 | 8.6 |

Notes:

- Capacity data includes water pumping watts and are base upon 15% (by volume) propylene glycol antifreeze solution.
- Desuperheater Capacity is based upon 0.4 GPM Flow per nominal ton at 90°F entering hot water temperature.
- The manufacturer reserves the right to make changes in design and construction at any time without notice.
- Extrapolation data down to 25°F for heating and interpolation between CFM, EWT & GPM data is permissible.
- See Flow Rate Selection on page 7 for proper application.

GT144 Performance Data: 12.0 Ton, 4400 CFM, High Capacity Heating

| EWT | GPM | WPD | | Heating | | | | | | Heating with Desuperheater | | | | | |
|-----|------|-----|------|---------|-------|-------|-------|-------|------|----------------------------|-------|-------|-------|------|------|
| | | PSI | FT | EAT | HC | HE | LAT | KW | COP | HC | HE | LAT | KW | DH | COP |
| 30 | 17.8 | 2.3 | 5.4 | 60 | 113.1 | 81.1 | 83.8 | 9.80 | 3.38 | 99.0 | 81.3 | 80.8 | 9.69 | 14.1 | 3.42 |
| | | | | 70 | 109.8 | 76.4 | 93.1 | 10.33 | 3.12 | 95.4 | 76.9 | 90.1 | 10.14 | 14.5 | 3.17 |
| | | | | 80 | 106.4 | 72.0 | 102.4 | 10.83 | 2.88 | 91.5 | 72.1 | 99.3 | 10.62 | 14.9 | 2.94 |
| | 24.9 | 4.4 | 10.1 | 60 | 116.5 | 84.6 | 84.5 | 9.91 | 3.45 | 102.0 | 84.8 | 81.5 | 9.69 | 14.5 | 3.52 |
| | | | | 70 | 113.3 | 79.6 | 93.8 | 10.43 | 3.18 | 98.4 | 80.1 | 90.7 | 10.22 | 15.0 | 3.25 |
| | | | | 80 | 110.2 | 74.8 | 103.2 | 10.96 | 2.95 | 94.8 | 75.3 | 99.9 | 10.72 | 15.5 | 3.01 |
| | 32.0 | 7.0 | 16.2 | 60 | 118.0 | 86.2 | 84.8 | 9.90 | 3.49 | 103.3 | 86.7 | 81.7 | 9.69 | 14.7 | 3.57 |
| | | | | 70 | 114.9 | 81.4 | 94.2 | 10.43 | 3.23 | 99.7 | 70.1 | 91.0 | 10.22 | 15.2 | 3.30 |
| | | | | 80 | 111.8 | 76.4 | 103.5 | 10.94 | 2.99 | 96.1 | 76.9 | 100.2 | 10.74 | 15.7 | 3.05 |
| 50 | 17.8 | 2.2 | 5.0 | 60 | 146.3 | 113.3 | 90.8 | 10.27 | 4.17 | 128.1 | 114.4 | 87.0 | 9.93 | 18.2 | 4.32 |
| | | | | 70 | 141.9 | 106.7 | 99.9 | 10.82 | 3.84 | 123.2 | 107.7 | 95.9 | 10.48 | 18.8 | 3.97 |
| | | | | 80 | 137.1 | 100.4 | 108.8 | 11.34 | 3.54 | 117.9 | 101.3 | 104.8 | 11.02 | 19.3 | 3.65 |
| | 24.9 | 4.1 | 9.4 | 60 | 152.5 | 118.7 | 92.1 | 10.47 | 4.27 | 133.5 | 120.1 | 88.1 | 10.13 | 19.0 | 4.41 |
| | | | | 70 | 147.4 | 112.1 | 101.0 | 11.02 | 3.92 | 128.0 | 113.1 | 96.9 | 10.66 | 19.5 | 4.05 |
| | | | | 80 | 142.7 | 105.1 | 110.0 | 11.59 | 3.61 | 122.7 | 106.4 | 105.8 | 11.21 | 20.0 | 3.73 |
| | 32.0 | 6.6 | 15.1 | 60 | 155.6 | 121.9 | 92.7 | 10.52 | 4.34 | 136.3 | 123.0 | 88.7 | 10.14 | 19.4 | 4.50 |
| | | | | 70 | 150.6 | 114.9 | 101.7 | 11.07 | 3.99 | 130.7 | 116.3 | 97.5 | 10.72 | 19.9 | 4.12 |
| | | | | 80 | 145.5 | 108.0 | 110.6 | 11.63 | 3.66 | 125.1 | 109.3 | 106.3 | 11.26 | 20.4 | 3.79 |
| 70 | 17.8 | 2.2 | 5.0 | 60 | 178.0 | 143.0 | 97.5 | 10.92 | 4.78 | 155.9 | 144.9 | 92.8 | 10.42 | 22.2 | 5.01 |
| | | | | 70 | 171.7 | 134.8 | 106.1 | 11.48 | 4.38 | 149.0 | 136.6 | 101.4 | 10.98 | 22.7 | 4.58 |
| | | | | 80 | 165.3 | 126.6 | 114.8 | 12.04 | 4.02 | 142.2 | 128.7 | 109.9 | 11.53 | 23.2 | 4.20 |
| | 24.9 | 3.9 | 9.0 | 60 | 186.9 | 150.6 | 99.3 | 11.24 | 4.87 | 163.7 | 153.1 | 94.4 | 10.72 | 23.3 | 5.11 |
| | | | | 70 | 180.3 | 142.1 | 107.9 | 11.83 | 4.47 | 156.5 | 144.2 | 102.9 | 11.30 | 23.8 | 4.68 |
| | | | | 80 | 173.6 | 133.5 | 116.5 | 12.44 | 4.09 | 149.3 | 135.7 | 111.4 | 11.87 | 24.4 | 4.29 |
| | 32.0 | 6.2 | 14.4 | 60 | 191.9 | 155.3 | 100.4 | 11.37 | 4.95 | 168.1 | 157.9 | 95.4 | 10.81 | 23.9 | 5.21 |
| | | | | 70 | 185.0 | 146.5 | 108.9 | 11.96 | 4.53 | 160.6 | 149.0 | 103.8 | 11.39 | 24.5 | 4.76 |
| | | | | 80 | 178.0 | 137.6 | 117.5 | 12.56 | 4.16 | 153.1 | 140.1 | 112.2 | 11.96 | 25.0 | 4.37 |
| 90 | 17.8 | 2.0 | 4.7 | 60 | 205.2 | 168.6 | 103.2 | 10.83 | 5.55 | 179.7 | 171.9 | 97.8 | 10.77 | 25.6 | 5.58 |
| | | | | 70 | 197.6 | 158.8 | 111.6 | 12.25 | 4.73 | 171.6 | 162.0 | 106.1 | 11.36 | 26.1 | 5.10 |
| | | | | 80 | 190.0 | 149.3 | 120.0 | 12.60 | 4.42 | 163.4 | 152.2 | 114.4 | 11.94 | 26.7 | 4.67 |
| | 24.9 | 3.6 | 8.3 | 60 | 216.9 | 178.7 | 105.6 | 11.89 | 5.35 | 189.9 | 182.4 | 100.0 | 11.18 | 27.0 | 5.69 |
| | | | | 70 | 209.0 | 168.6 | 114.0 | 12.52 | 4.89 | 181.4 | 172.2 | 108.2 | 11.79 | 27.6 | 5.20 |
| | | | | 80 | 200.8 | 158.5 | 122.3 | 13.14 | 4.48 | 172.6 | 161.7 | 116.3 | 12.39 | 28.2 | 4.75 |
| | 32.0 | 5.8 | 13.3 | 60 | 224.1 | 185.0 | 107.2 | 12.08 | 5.44 | 196.3 | 189.0 | 101.3 | 11.33 | 27.9 | 5.80 |
| | | | | 70 | 215.6 | 174.6 | 115.4 | 12.70 | 4.98 | 187.2 | 178.6 | 109.4 | 11.95 | 28.5 | 5.29 |
| | | | | 80 | 207.1 | 164.2 | 123.6 | 13.33 | 4.55 | 178.1 | 167.7 | 117.5 | 12.55 | 29.1 | 4.84 |

Notes:

1. Capacity data includes water pumping watts and are base upon 15% (by volume) propylene glycol antifreeze solution.
2. Desuperheater Capacity is based upon 0.4 GPM Flow per nominal ton at 90°F entering hot water temperature.
3. The manufacturer reserves the right to make changes in design and construction at any time without notice.
4. Extrapolation data down to 25°F for heating and interpolation between CFM, EWT & GPM data is permissible.
5. See Flow Rate Selection on page 7 for proper application.

GT144 Performance Data: 12.0 Ton, 2400 CFM, Low Capacity Heating

| EWT | GPM | WPD | | Heating | | | | | | Heating with Desuperheater | | | | | |
|-----|------|-----|------|---------|-------|------|-------|------|------|----------------------------|------|-------|------|------|------|
| | | PSI | FT | EAT | HC | HE | LAT | KW | COP | HC | HE | LAT | KW | DH | COP |
| 30 | 10.0 | 2.2 | 5.0 | 60 | 56.5 | 40.5 | 81.8 | 5.04 | 3.28 | 49.5 | 40.6 | 79.1 | 4.99 | 7.0 | 3.32 |
| | | | | 70 | 54.9 | 38.2 | 91.2 | 5.32 | 3.02 | 47.6 | 38.4 | 88.4 | 5.22 | 7.3 | 3.08 |
| | | | | 80 | 53.2 | 36.0 | 100.5 | 5.57 | 2.80 | 45.7 | 36.0 | 97.6 | 5.46 | 7.5 | 2.85 |
| | 14.0 | 4.0 | 9.3 | 60 | 58.2 | 42.3 | 82.5 | 5.10 | 3.35 | 51.0 | 42.4 | 79.7 | 4.99 | 7.2 | 3.42 |
| | | | | 70 | 56.6 | 39.7 | 91.8 | 5.37 | 3.09 | 49.1 | 40.0 | 89.0 | 5.26 | 7.5 | 3.15 |
| | | | | 80 | 55.1 | 37.4 | 101.2 | 5.64 | 2.86 | 47.3 | 37.6 | 98.3 | 5.52 | 7.7 | 2.93 |
| | 18.0 | 6.5 | 15.0 | 60 | 59.0 | 43.1 | 82.7 | 5.09 | 3.39 | 51.6 | 43.3 | 79.9 | 4.98 | 7.3 | 3.47 |
| | | | | 70 | 57.4 | 40.7 | 92.1 | 5.37 | 3.14 | 49.8 | 35.0 | 89.2 | 5.26 | 7.6 | 3.20 |
| | | | | 80 | 55.9 | 38.2 | 101.5 | 5.63 | 2.91 | 48.0 | 38.4 | 98.5 | 5.53 | 7.8 | 2.96 |
| 50 | 10.0 | 2.0 | 4.7 | 60 | 73.1 | 56.6 | 88.2 | 5.29 | 4.05 | 64.0 | 57.1 | 84.7 | 5.11 | 9.1 | 4.19 |
| | | | | 70 | 70.9 | 53.3 | 97.4 | 5.57 | 3.73 | 61.5 | 53.8 | 93.7 | 5.39 | 9.4 | 3.85 |
| | | | | 80 | 68.5 | 50.2 | 106.4 | 5.84 | 3.44 | 58.9 | 50.6 | 102.7 | 5.67 | 9.6 | 3.54 |
| | 14.0 | 3.7 | 8.6 | 60 | 76.2 | 59.3 | 89.4 | 5.39 | 4.14 | 66.7 | 60.0 | 85.7 | 5.21 | 9.5 | 4.28 |
| | | | | 70 | 73.7 | 56.0 | 98.4 | 5.67 | 3.80 | 63.9 | 56.5 | 94.7 | 5.49 | 9.7 | 3.93 |
| | | | | 80 | 71.3 | 52.5 | 107.5 | 5.97 | 3.50 | 61.3 | 53.2 | 103.6 | 5.77 | 10.0 | 3.62 |
| | 18.0 | 6.0 | 14.0 | 60 | 77.7 | 60.9 | 90.0 | 5.41 | 4.21 | 68.1 | 61.4 | 86.3 | 5.22 | 9.7 | 4.37 |
| | | | | 70 | 75.2 | 57.4 | 99.0 | 5.70 | 3.87 | 65.3 | 58.1 | 95.2 | 5.51 | 9.9 | 4.00 |
| | | | | 80 | 72.7 | 53.9 | 108.0 | 5.99 | 3.56 | 62.5 | 54.6 | 104.1 | 5.79 | 10.2 | 3.68 |
| 70 | 10.0 | 2.0 | 4.7 | 60 | 88.9 | 71.4 | 94.3 | 5.62 | 4.64 | 77.9 | 72.4 | 90.0 | 5.36 | 11.1 | 4.86 |
| | | | | 70 | 85.8 | 67.3 | 103.1 | 5.91 | 4.25 | 74.4 | 68.2 | 98.7 | 5.65 | 11.3 | 4.45 |
| | | | | 80 | 82.6 | 63.2 | 111.9 | 6.20 | 3.90 | 71.0 | 64.3 | 107.4 | 5.93 | 11.6 | 4.08 |
| | 14.0 | 3.6 | 8.3 | 60 | 93.4 | 75.2 | 96.0 | 5.79 | 4.73 | 81.7 | 76.5 | 91.5 | 5.52 | 11.6 | 4.96 |
| | | | | 70 | 90.1 | 71.0 | 104.7 | 6.09 | 4.34 | 78.2 | 72.0 | 100.2 | 5.81 | 11.9 | 4.54 |
| | | | | 80 | 86.7 | 66.7 | 113.5 | 6.41 | 3.97 | 74.6 | 67.8 | 108.8 | 6.11 | 12.2 | 4.16 |
| | 18.0 | 5.8 | 13.3 | 60 | 95.9 | 77.6 | 97.0 | 5.85 | 4.80 | 84.0 | 78.9 | 92.4 | 5.56 | 11.9 | 5.05 |
| | | | | 70 | 92.4 | 73.2 | 105.7 | 6.16 | 4.40 | 80.2 | 74.4 | 100.9 | 5.86 | 12.2 | 4.62 |
| | | | | 80 | 89.0 | 68.8 | 114.3 | 6.46 | 4.03 | 76.5 | 70.0 | 109.5 | 6.15 | 12.5 | 4.24 |
| 90 | 10.0 | 1.9 | 4.3 | 60 | 102.5 | 84.2 | 99.6 | 5.57 | 5.39 | 89.8 | 85.8 | 94.6 | 5.54 | 12.8 | 5.42 |
| | | | | 70 | 98.7 | 79.3 | 108.1 | 6.30 | 4.59 | 85.7 | 80.9 | 103.1 | 5.84 | 13.1 | 4.95 |
| | | | | 80 | 95.0 | 74.6 | 116.6 | 6.49 | 4.29 | 81.6 | 76.0 | 111.5 | 6.14 | 13.3 | 4.53 |
| | 14.0 | 3.3 | 7.7 | 60 | 108.4 | 89.3 | 101.8 | 6.12 | 5.19 | 94.9 | 91.1 | 96.6 | 5.75 | 13.5 | 5.52 |
| | | | | 70 | 104.4 | 84.2 | 110.3 | 6.44 | 4.75 | 90.6 | 86.0 | 105.0 | 6.07 | 13.8 | 5.04 |
| | | | | 80 | 100.3 | 79.2 | 118.7 | 6.77 | 4.34 | 86.2 | 80.8 | 113.3 | 6.37 | 14.1 | 4.61 |
| | 18.0 | 5.3 | 12.3 | 60 | 112.0 | 92.4 | 103.2 | 6.22 | 5.28 | 98.0 | 94.4 | 97.8 | 5.83 | 13.9 | 5.63 |
| | | | | 70 | 107.7 | 87.2 | 111.6 | 6.54 | 4.83 | 93.5 | 89.2 | 106.1 | 6.15 | 14.2 | 5.14 |
| | | | | 80 | 103.5 | 82.0 | 119.9 | 6.86 | 4.42 | 88.9 | 83.8 | 114.3 | 6.46 | 14.5 | 4.70 |

Notes:

- Capacity data includes water pumping watts and are base upon 15% (by volume) propylene glycol antifreeze solution.
- Desuperheater Capacity is based upon 0.4 GPM Flow per nominal ton at 90°F entering hot water temperature.
- The manufacturer reserves the right to make changes in design and construction at any time without notice.
- Extrapolation data down to 25°F for heating and interpolation between CFM, EWT & GPM data is permissible.
- See Flow Rate Selection on page 7 for proper application.

GT144 Performance Data: 12.0 Ton, 4400 CFM, High Capacity Cooling

| EWT | GPM | WPD | | EAT DB/ WB | Cooling | | | | | Cooling with Desuperheater | | | | | |
|-----|------|-----|------|------------------|---------|-------|-------|-------|------|----------------------------|-------|-------|-------|------|------|
| | | PSI | FT | | TC | SC | HR | KW | EER | TC | SC | HR | KW | DH | EER |
| 50 | 17.8 | 2.3 | 5.2 | 75/63 | 146.9 | 102.7 | 173.0 | 8.98 | 16.4 | 146.9 | 102.9 | 173.0 | 8.81 | 12.4 | 16.7 |
| | | | | 80/67 | 159.6 | 106.9 | 184.2 | 9.19 | 17.4 | 159.6 | 107.1 | 183.9 | 8.99 | 12.7 | 17.8 |
| | | | | 85/71 | 172.3 | 111.2 | 195.1 | 9.37 | 18.4 | 172.3 | 111.4 | 195.1 | 9.18 | 13.0 | 18.8 |
| | 24.9 | 4.1 | 9.4 | 75/63 | 148.4 | 103.6 | 173.6 | 8.58 | 17.3 | 148.4 | 103.8 | 173.6 | 8.47 | 11.8 | 17.5 |
| | | | | 80/67 | 161.1 | 107.8 | 184.5 | 8.76 | 18.4 | 161.1 | 108.0 | 184.8 | 6.65 | 12.1 | 18.6 |
| | | | | 85/71 | 174.2 | 112.1 | 195.7 | 8.94 | 19.5 | 174.2 | 112.3 | 195.7 | 8.83 | 12.4 | 19.7 |
| | 32.0 | 6.6 | 15.1 | 75/63 | 149.9 | 103.6 | 174.5 | 8.33 | 18.0 | 149.9 | 103.8 | 174.5 | 8.30 | 11.2 | 18.1 |
| | | | | 80/67 | 163.0 | 107.8 | 185.7 | 8.50 | 19.2 | 163.0 | 108.0 | 185.7 | 8.47 | 11.5 | 19.2 |
| | | | | 85/71 | 176.0 | 112.1 | 196.6 | 8.68 | 20.3 | 176.0 | 112.3 | 196.9 | 8.62 | 11.8 | 20.4 |
| 70 | 17.8 | 2.2 | 5.0 | 75/63 | 137.8 | 100.9 | 168.4 | 10.81 | 12.8 | 138.6 | 101.0 | 168.7 | 10.55 | 17.8 | 13.1 |
| | | | | 80/67 | 149.6 | 104.8 | 179.0 | 11.05 | 13.5 | 150.5 | 105.3 | 179.3 | 10.75 | 18.4 | 14.0 |
| | | | | 85/71 | 161.7 | 109.0 | 189.9 | 11.24 | 14.4 | 162.7 | 109.5 | 190.3 | 11.00 | 19.0 | 14.8 |
| | 24.9 | 3.9 | 9.0 | 75/63 | 139.9 | 101.8 | 169.0 | 10.28 | 13.6 | 140.7 | 102.3 | 169.6 | 10.11 | 17.2 | 13.9 |
| | | | | 80/67 | 152.1 | 106.0 | 179.9 | 10.51 | 14.5 | 152.9 | 106.5 | 180.5 | 10.34 | 17.8 | 14.8 |
| | | | | 85/71 | 164.2 | 110.3 | 190.8 | 10.71 | 15.3 | 165.1 | 110.8 | 191.5 | 10.50 | 18.1 | 15.7 |
| | 32.0 | 6.2 | 14.4 | 75/63 | 141.1 | 101.8 | 169.9 | 9.97 | 14.2 | 142.0 | 102.3 | 170.5 | 9.92 | 16.3 | 14.3 |
| | | | | 80/67 | 153.6 | 106.0 | 180.8 | 10.17 | 15.1 | 154.5 | 106.5 | 181.5 | 10.12 | 16.9 | 15.3 |
| | | | | 85/71 | 165.7 | 110.3 | 191.4 | 10.38 | 16.0 | 166.6 | 110.8 | 192.4 | 10.29 | 17.5 | 16.2 |
| 90 | 17.8 | 2.0 | 4.7 | 75/63 | 125.4 | 96.6 | 162.0 | 13.36 | 9.4 | 126.6 | 97.4 | 162.6 | 12.94 | 23.5 | 9.8 |
| | | | | 80/67 | 136.3 | 100.6 | 172.3 | 13.61 | 10.0 | 137.6 | 101.3 | 173.0 | 13.22 | 24.1 | 10.4 |
| | | | | 85/71 | 147.2 | 104.8 | 182.9 | 13.83 | 10.6 | 148.6 | 105.3 | 183.6 | 13.47 | 24.7 | 11.0 |
| | 24.9 | 3.6 | 8.4 | 75/63 | 127.8 | 97.5 | 163.0 | 12.57 | 10.2 | 129.0 | 98.3 | 163.9 | 12.31 | 22.6 | 10.5 |
| | | | | 80/67 | 139.0 | 101.8 | 173.3 | 12.88 | 10.8 | 140.4 | 102.3 | 174.2 | 12.55 | 23.2 | 11.2 |
| | | | | 85/71 | 150.2 | 105.7 | 183.6 | 13.06 | 11.5 | 151.7 | 106.5 | 184.8 | 13.84 | 23.8 | 11.8 |
| | 32.0 | 5.8 | 13.4 | 75/63 | 129.3 | 97.5 | 163.3 | 12.25 | 10.6 | 130.6 | 98.3 | 164.5 | 12.09 | 21.7 | 10.8 |
| | | | | 80/67 | 140.5 | 101.8 | 173.6 | 12.47 | 11.3 | 141.9 | 102.3 | 175.1 | 12.34 | 22.3 | 11.5 |
| | | | | 85/71 | 151.7 | 105.7 | 184.2 | 12.76 | 11.9 | 153.2 | 106.5 | 185.7 | 12.55 | 22.9 | 12.2 |
| 110 | 17.8 | 2.0 | 4.5 | 75/63 | 109.3 | 90.6 | 154.2 | 16.64 | 6.6 | 111.2 | 91.3 | 154.8 | 16.15 | 29.0 | 6.9 |
| | | | | 80/67 | 118.7 | 94.2 | 164.2 | 16.86 | 7.0 | 120.7 | 95.0 | 164.8 | 16.42 | 29.9 | 7.4 |
| | | | | 85/71 | 128.4 | 97.8 | 173.9 | 17.28 | 7.4 | 130.6 | 98.9 | 174.5 | 16.69 | 30.8 | 7.8 |
| | 24.9 | 3.6 | 8.3 | 75/63 | 112.1 | 91.5 | 154.8 | 15.57 | 7.2 | 114.0 | 92.2 | 155.7 | 15.33 | 28.1 | 7.4 |
| | | | | 80/67 | 122.1 | 95.1 | 164.5 | 15.92 | 7.7 | 124.1 | 95.9 | 165.7 | 15.55 | 29.0 | 8.0 |
| | | | | 85/71 | 131.8 | 99.0 | 174.5 | 16.35 | 8.1 | 134.0 | 99.8 | 175.7 | 15.86 | 29.6 | 8.5 |
| | 32.0 | 5.7 | 13.2 | 75/63 | 113.3 | 91.5 | 154.8 | 15.24 | 7.4 | 115.2 | 92.2 | 156.3 | 15.02 | 26.8 | 7.7 |
| | | | | 80/67 | 123.3 | 95.1 | 164.5 | 15.45 | 8.0 | 125.4 | 95.9 | 166.3 | 15.41 | 27.8 | 8.1 |
| | | | | 85/71 | 133.0 | 99.0 | 174.5 | 15.74 | 8.4 | 135.2 | 99.8 | 176.3 | 15.57 | 28.7 | 8.7 |

Notes:

1. Capacity data includes water pumping watts and are base upon 15% (by volume) propylene glycol antifreeze solution.
2. Desuperheater Capacity is based upon 0.4 GPM Flow per nominal ton at 90°F entering hot water temperature.
3. The manufacturer reserves the right to make changes in design and construction at any time without notice.
4. Extrapolation data down to 25°F for heating and interpolation between CFM, EWT & GPM data is permissible.
5. See Flow Rate Selection on page 7 for proper application.

GT144 Performance Data: 12.0 Ton, 2400 CFM, Low Capacity Cooling

| EWT | GPM | WPD | | EAT DB/ WB | Cooling | | | | | Cooling with Desuperheater | | | | | |
|-----|------|-----|------|------------------|---------|------|------|------|------|----------------------------|------|------|------|------|------|
| | | PSI | FT | | TC | SC | HR | KW | EER | TC | SC | HR | KW | DH | EER |
| 50 | 10.0 | 2.1 | 4.8 | 75/63 | 73.5 | 51.3 | 86.5 | 4.52 | 16.2 | 73.5 | 51.4 | 86.5 | 4.44 | 6.2 | 16.6 |
| | | | | 80/67 | 79.8 | 53.5 | 92.1 | 4.63 | 17.3 | 79.8 | 53.6 | 91.9 | 4.52 | 6.3 | 17.6 |
| | | | | 85/75 | 86.2 | 55.6 | 97.5 | 4.72 | 18.3 | 86.2 | 55.7 | 97.6 | 4.62 | 6.5 | 18.7 |
| | 14.0 | 3.7 | 8.6 | 75/63 | 74.2 | 51.8 | 86.8 | 4.32 | 17.2 | 74.2 | 51.9 | 86.8 | 4.26 | 5.9 | 17.4 |
| | | | | 80/67 | 80.6 | 53.9 | 92.2 | 4.41 | 18.3 | 80.6 | 54.0 | 92.4 | 4.36 | 6.0 | 18.5 |
| | | | | 85/75 | 87.1 | 56.0 | 97.8 | 4.50 | 19.4 | 87.1 | 56.1 | 97.9 | 4.45 | 6.2 | 19.6 |
| | 18.0 | 6.0 | 14.0 | 75/63 | 75.0 | 51.8 | 87.2 | 4.19 | 17.9 | 75.0 | 51.9 | 87.2 | 4.18 | 5.6 | 18.0 |
| | | | | 80/67 | 81.5 | 53.9 | 92.8 | 4.28 | 19.0 | 81.5 | 54.0 | 92.9 | 4.26 | 5.7 | 19.1 |
| | | | | 85/75 | 88.0 | 56.0 | 98.3 | 4.37 | 20.1 | 88.0 | 56.1 | 98.5 | 4.34 | 5.9 | 20.3 |
| 70 | 10.0 | 2.0 | 4.7 | 75/63 | 68.9 | 50.4 | 84.2 | 5.44 | 12.7 | 69.3 | 50.5 | 84.4 | 5.31 | 8.9 | 13.1 |
| | | | | 80/67 | 74.8 | 52.4 | 89.5 | 5.56 | 13.4 | 75.2 | 52.6 | 89.7 | 5.41 | 9.2 | 13.9 |
| | | | | 85/75 | 80.9 | 54.5 | 95.0 | 5.66 | 14.3 | 81.3 | 54.8 | 95.1 | 5.54 | 9.5 | 14.7 |
| | 14.0 | 3.6 | 8.3 | 75/63 | 70.0 | 50.9 | 84.5 | 5.17 | 13.5 | 70.4 | 51.1 | 84.8 | 5.09 | 8.6 | 13.8 |
| | | | | 80/67 | 76.0 | 53.0 | 90.0 | 5.29 | 14.4 | 76.5 | 53.3 | 90.3 | 5.21 | 8.9 | 14.7 |
| | | | | 85/75 | 82.1 | 55.1 | 95.4 | 5.39 | 15.2 | 82.6 | 55.4 | 95.7 | 5.28 | 9.1 | 15.6 |
| | 18.0 | 5.8 | 13.3 | 75/63 | 70.6 | 50.9 | 85.0 | 5.02 | 14.1 | 71.0 | 51.1 | 85.3 | 4.99 | 8.1 | 14.2 |
| | | | | 80/67 | 76.8 | 53.0 | 90.4 | 5.12 | 15.0 | 77.2 | 53.3 | 90.7 | 5.10 | 8.5 | 15.2 |
| | | | | 85/75 | 82.8 | 55.1 | 95.7 | 5.22 | 15.9 | 83.3 | 55.4 | 96.2 | 5.18 | 8.7 | 16.1 |
| 90 | 10.0 | 1.9 | 4.3 | 75/63 | 62.7 | 48.3 | 81.0 | 6.72 | 9.3 | 63.3 | 48.7 | 81.3 | 6.52 | 11.8 | 9.7 |
| | | | | 80/67 | 68.2 | 50.3 | 86.2 | 6.85 | 9.9 | 68.8 | 50.7 | 86.5 | 6.66 | 12.1 | 10.3 |
| | | | | 85/75 | 73.6 | 52.4 | 91.5 | 6.96 | 10.6 | 74.3 | 52.6 | 91.8 | 6.78 | 12.4 | 11.0 |
| | 14.0 | 3.3 | 7.7 | 75/63 | 63.9 | 48.8 | 81.5 | 6.33 | 10.1 | 64.5 | 49.2 | 81.9 | 6.20 | 11.3 | 10.4 |
| | | | | 80/67 | 69.5 | 50.9 | 86.6 | 6.48 | 10.7 | 70.2 | 51.1 | 87.1 | 6.31 | 11.6 | 11.1 |
| | | | | 85/75 | 75.1 | 52.9 | 91.8 | 6.57 | 11.4 | 75.8 | 53.3 | 92.4 | 6.46 | 11.9 | 11.7 |
| | 18.0 | 5.4 | 12.4 | 75/63 | 64.7 | 48.8 | 81.6 | 6.16 | 10.5 | 65.3 | 49.2 | 82.2 | 6.09 | 10.9 | 10.7 |
| | | | | 80/67 | 70.3 | 50.9 | 86.8 | 6.28 | 11.2 | 70.9 | 51.1 | 87.5 | 6.21 | 11.2 | 11.4 |
| | | | | 85/75 | 75.9 | 52.9 | 92.1 | 6.42 | 11.8 | 76.6 | 53.3 | 92.9 | 6.32 | 11.5 | 12.1 |
| 110 | 10.0 | 1.8 | 4.2 | 75/63 | 54.7 | 45.3 | 77.1 | 8.37 | 6.5 | 55.6 | 45.7 | 77.4 | 8.13 | 14.5 | 6.8 |
| | | | | 80/67 | 59.4 | 47.1 | 82.1 | 8.49 | 7.0 | 60.4 | 47.5 | 82.4 | 8.26 | 14.9 | 7.3 |
| | | | | 85/75 | 64.2 | 48.9 | 86.9 | 8.70 | 7.4 | 65.3 | 49.5 | 87.2 | 8.40 | 15.4 | 7.8 |
| | 14.0 | 3.3 | 7.7 | 75/63 | 56.0 | 45.7 | 77.4 | 7.84 | 7.2 | 57.0 | 46.1 | 77.8 | 7.72 | 14.0 | 7.4 |
| | | | | 80/67 | 61.0 | 47.6 | 82.2 | 8.01 | 7.6 | 62.1 | 47.9 | 82.8 | 7.83 | 14.5 | 7.9 |
| | | | | 85/75 | 65.9 | 49.5 | 87.2 | 8.23 | 8.0 | 67.0 | 49.9 | 87.8 | 7.98 | 14.8 | 8.4 |
| | 18.0 | 5.3 | 12.1 | 75/63 | 56.6 | 45.7 | 77.4 | 7.67 | 7.4 | 57.6 | 46.1 | 78.1 | 7.56 | 13.4 | 7.6 |
| | | | | 80/67 | 61.6 | 47.6 | 82.2 | 7.78 | 7.9 | 62.7 | 47.9 | 83.1 | 7.75 | 13.9 | 8.1 |
| | | | | 85/75 | 66.5 | 49.5 | 87.2 | 7.92 | 8.4 | 67.6 | 49.9 | 88.1 | 7.84 | 14.3 | 8.6 |

Notes:

1. Capacity data includes water pumping watts and are base upon 15% (by volume) propylene glycol antifreeze solution.
2. Desuperheater Capacity is based upon 0.4 GPM Flow per nominal ton at 90°F entering hot water temperature.
3. The manufacturer reserves the right to make changes in design and construction at any time without notice.
4. Extrapolation data down to 25°F for heating and interpolation between CFM, EWT & GPM data is permissible.
5. See Flow Rate Selection on page 7 for proper application.

Physical Data

| Dual Capacity and Dual Compressor (GT096 - 144) | | | | | | | | |
|--|--------------|--------------|--------------|--------------|--------------|------------------------|------------------------|------------------------|
| Model Number | GT024 | GT036 | GT048 | GT060 | GT072 | GT096 | GT120 | GT144 |
| Fan Wheel (in.) | 9 x 7 | 9 x 9 | 11x10 | 11x10 | | 12 x 12 | 15 x 15 | 15 x 15 |
| Fan Motor ECM (HP) | 1/2 | 1/2 | 1.0 | 1.0 | | 2 - 1.0 | 2 - 1.0 | 2 - 1.0 |
| PSC (HP) | - | - | - | - | | 2 - 0.5 or 1 - 1.5* | 2 - 1.0 or 1 - 2.0* | 2 - 1.0 or 1 - 2.0* |
| Refrigerant Charge (oz.) | 48.0 | 64.0 | 64.0 | 80.0 | | 64.0 Each | 72.0 Each | 80.0 Each |
| Air Coil | | | | | | | | |
| Face Area (Sq.Ft.) | 4.2 | 5.6 | 6.3 | 6.3 | | 8.9 | 8.9 | 8.9 |
| Dimensions (in.) | 20x30 | 25x32 | 25x36 | 25x36 | | 34x36 | 34x36 | 34x36 |
| Number Of Rows | 3 | 3 | 3 | 4 | | 3 | 4 | 5 |
| Filter 1" Thick | 30x24 | 32x28 | 36x28 | 36x28 | | 36x38 | 36x38 | 36x38 |
| Unit Weight (nominal) - lbs | 190 | 270 | 310 | 360 | | 600 | 680 | 700 |
| Horizontal – Single Compressor Dual Capacity | | | | | | | | |
| Fan Wheel (in.) | 9 x 7 | 9 x 9 | 11x10 | 11x10 | | | | |
| Fan Motor (HP) ECM | 1/2 | 1/2 | 1.0 | 1.0 | | | | |
| Refrigerant Charge (oz.) | 48.0 | 64.0 | 64.0 | 80.0 | | | | |
| Air Coil | | | | | | | | |
| Face Area (Sq.Ft.) | 4.0 | 5.5 | 6.4 | 6.4 | | | | |
| Dimensions (in.) | 18x32 | 18x44 | 20x46 | 20x46 | | | | |
| Number Of Rows | 3 | 3 | 3 | 4 | | | | |
| Filter 1" Thick | 18x36 | 18x48 | 20x50 | 20x50 | | | | |
| Unit Weight (nominal) - lbs | 200 | 270 | 310 | 360 | | | | |

Dimensional Data: Vertical Cabinets

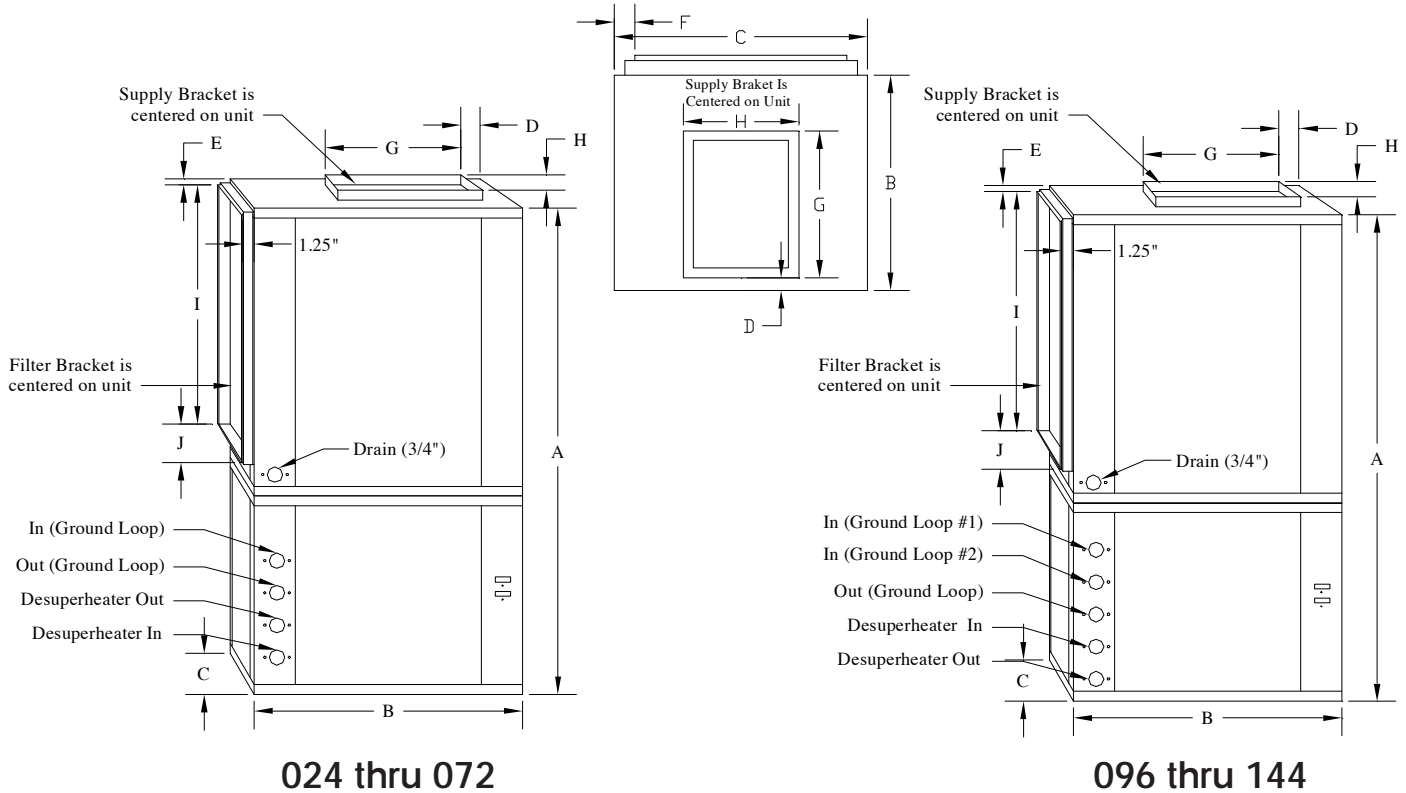

024 thru 072

096 thru 144

| Model | Dimensional Data | | | | | | Supply Air | | Return Air | | Water Loop | |
|-------|------------------|------|------|------|-----|-----|------------|------|------------|-------|------------|--------|
| | A | B | C | D | E | F | G | H | I | J | IN | OUT |
| 024 | 50.25 | 22.0 | 25.5 | 0.75 | 1.7 | 2.4 | 14.0 | 12.0 | 28.2 | 20.7 | 3/4" | 3/4" |
| 036 | 54.25 | 26.0 | 30.5 | 0.75 | 1.7 | 2.4 | 14.0 | 16.0 | 30.2 | 25.7 | 3/4" | 3/4" |
| 048 | 60.25 | 26.0 | 30.5 | 0.75 | 1.8 | 2.4 | 16.0 | 16.0 | 34.2 | 25.7 | 1.0" | 1.0" |
| 060 | 60.25 | 28.0 | 30.5 | 0.75 | 1.7 | 2.4 | 16.0 | 18.0 | 34.2 | 25.7 | 1.0" | 1.0" |
| 072 | 60.25 | 28.0 | 30.5 | 0.75 | 1.7 | 2.4 | 16.0 | 18.0 | 34.2 | 25.7 | 1.0" | 1.0" |
| 096 | 59.25 | 32.0 | 39.5 | 0.25 | 1.7 | 2.4 | 20.0 | 24.0 | 34.00 | 34.75 | 1.0" | 1-1/4" |
| 120 | 59.25 | 32.0 | 39.5 | 0.25 | 1.7 | 2.4 | 20.0 | 24.0 | 34.00 | 34.75 | 1.0" | 1-1/2" |
| 144 | 59.25 | 32.0 | 39.5 | 0.25 | 1.7 | 2.4 | 20.0 | 24.0 | 34.00 | 34.75 | 1.0" | 1-1/2" |

Notes

Down Flow equipment has the same dimensional data in an inverted configuration.
 All Desuperheater connections are 3/4" FPT.
 All measurements are in inches.

Dimensional Data: Horizontal Cabinets

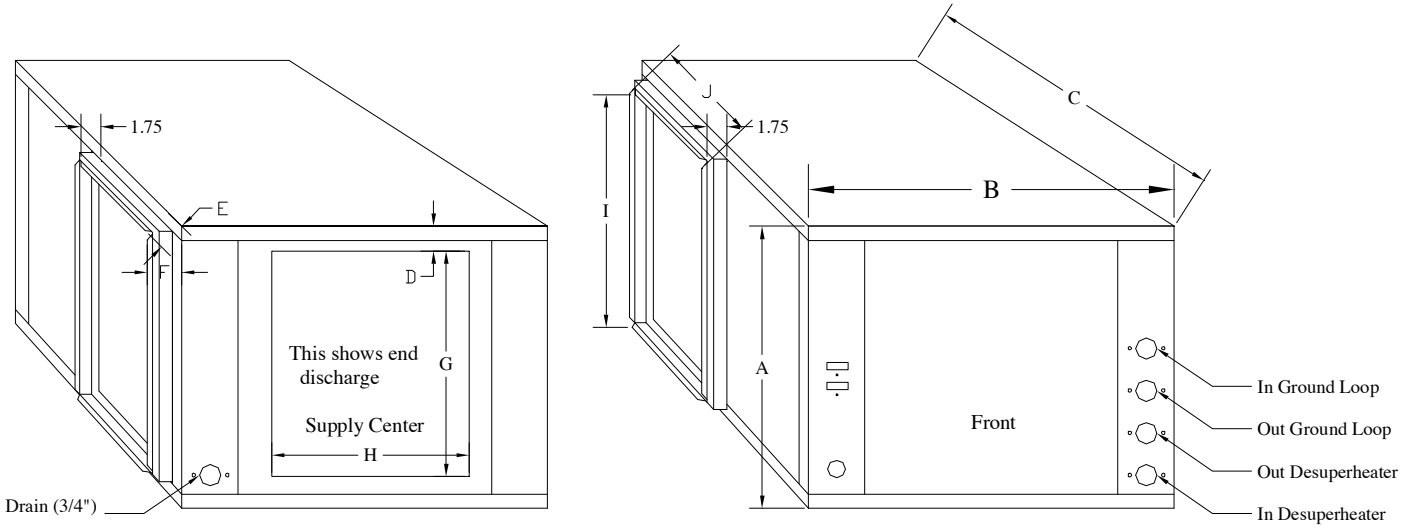

Note: Electro Module (Strip Heater) can only be internal mounted in end discharge units, as show on above drawing.

| Model | Dimensional Data | | | | | | Supply Air | | Return Air | | Water Loop | |
|-------|------------------|------|------|-----|------|-----|------------|------|------------|-------|------------|------|
| | A | B | C | D | E | F | G | H | I | J | IN | OUT |
| 024 | 22.0 | 26.0 | 54.0 | 2.0 | 1.75 | 2.0 | 14.0 | 12.0 | 16.75 | 33.25 | 3/4" | 3/4" |
| 036 | 22.0 | 28.0 | 66.0 | 2.0 | 1.75 | 2.0 | 16.0 | 14.0 | 16.75 | 45.25 | 3/4" | 3/4" |
| 048 | 24.0 | 30.0 | 68.0 | 2.0 | 1.72 | 2.0 | 16.0 | 16.0 | 18.75 | 47.25 | 1.0" | 1.0" |
| 060 | 24.0 | 30.0 | 68.0 | 2.0 | 1.75 | 2.0 | 16.0 | 16.0 | 18.75 | 47.25 | 1.0" | 1.0" |

Notes

All Desuperheater connections are 3/4" FPT.
All measurements are in inches.

Electrical Data: Unit Electrical Data

| Model | 60Hz Power | | Compressor | | Fan Motor | | Total Unit FLA | Minimum Circuit Ampacity | Minimum Circuit Size |
|--|------------|-------|------------|------------|-----------|---------|----------------|--------------------------|----------------------|
| | Volts | Phase | RLA | LRA | FLA | LRA | | | |
| 024 | 208-230 | 1 | 6.2 | 52.0 | 1.1 | 2.5 | 7.3 | 10.0 | 15.0 |
| 036 | 208-230 | 1 | 13.3 | 82.0 | 1.7 | 4.5 | 15.0 | 20.0 | 30.0 |
| | 208-230 | 3 | 8.1 | 58.0 | 1.7 | 4.5 | 9.8 | 15.0 | 20.0 |
| 048 | 208-230 | 1 | 17.3 | 96.0 | 3.1 | 8.0 | 20.4 | 30.0 | 45.0 |
| | 208-230 | 3 | 11.5 | 88.0 | 3.4 | 8.0 | 14.6 | 20.0 | 30.0 |
| 060 | 208-230 | 1 | 22.2 | 118.0 | 4.3 | 10.4 | 26.5 | 35.0 | 55.0 |
| | 208-230 | 3 | 14.9 | 135.0 | 4.3 | 10.4 | 19.2 | 25.0 | 40.0 |
| 072 | 208-230 | 1 | 25.0 | 125.0 | 4.3 | 10.4 | 29.3 | 40 | 60 |
| | 208-230 | 3 | 15.5 | 110 | 4.3 | 10.4 | 19.8 | 30 | 45 |
| 096* | 208-230 | 1 | 21.8 Each | 134.0 Each | 2-1.7* | 2-4.5* | 47 | 30.0 Each | 45.0 Each |
| | 208-230 | 3 | 14.4 Each | 123.0 Each | 2-1.7* | 2-4.5* | 32.2 | 25.0 Each | 30.0 Each |
| 120* | 208-230 | 1 | 24.7 Each | 158.0 Each | 2-5.0* | 2-38.3* | 58 | 40.0 Each | 55.0 Each |
| | 208-230 | 3 | 16.3 Each | 155.0 Each | 2-5.0* | 2-38.3* | 41.2 | 30.0 Each | 45.0 Each |
| 144* | 208-230 | 1 | 25.7 Each | 148.0 Each | 2-5.4* | 2-40.0* | 62.2 | 45.0 Each | 50.0 Each |
| | 208-230 | 3 | 18.2 Each | 149.0 Each | 2-5.4* | 2-40.0* | 47.2 | 35.0 Each | 40.0 Each |
| Shown Below Are the Specifications For Belt Driven Blowers (Optional). | | | | | | | | | |
| 096 | 208-230 | 1 | 21.8 Each | 134.0 Each | 8.9 | 50.3 | 52.5 | 40.0 Each | 45.0 Each |
| | 208-230 | 3 | 14.4 Each | 123.0 Each | 4.4 | 26.4 | 33.2 | 25.0 Each | 30.0 Each |
| | 460 | 3 | 6.2 Each | 46.0 Each | 2 | 12.1 | 14.4 | 10.0 Each | 10.0 Each |
| | 575 | 3 | 5.0 Each | 37.0 Each | 1.4 | 8.4 | 14 | 10.0 Each | 10.0 Each |
| 120 | 208-230 | 1 | 24.7 Each | 158.0 Each | 10 | 66 | 59.4 | 80.0 Each | 100.0 Each |
| | 208-230 | 3 | 16.3 Each | 155.0 Each | 5.8 | 34.8 | 38.4 | 50.0 Each | 60.0 Each |
| | 460 | 3 | 8.0 Each | 75.0 Each | 2.6 | 15.6 | 18.6 | 10.0 Each | 15.0 Each |
| | 575 | 3 | 6.5 Each | 54.0 Each | 1.9 | 13.8 | 14.9 | 10.0 Each | 15.0 Each |
| 144 | 208-230 | 1 | 25.7 Each | 148.0 Each | 11 | 66 | 62.4 | 45.0 Each | 55.0 Each |
| | 208-230 | 3 | 18.2 Each | 149.0 Each | 5.8 | 34.8 | 42.2 | 30.0 Each | 40.0 Each |
| | 460 | 3 | 9.1 Each | 75.0 Each | 3 | 15.6 | 21.2 | 15.0 Each | 20.0 Each |
| | 575 | 3 | 7.3 Each | 54.0 Each | 2.3 | 13.8 | 16.9 | 10.0 Each | 15.0 Each |

Notes:

* These models come standard with direct drive twin blowers. Fan motor FLA & RLA are shown for each motor.

1. 096, 120 & 144 models come with two compressors; separate refrigerant systems.

These models may be operated as two-stage equipment.

PSC = Blower capacity remains constant.

ECM = Blower Capacity variable speed.

2. Make sure compressors and blower motors do not run backwards on three-phase equipment.

3. Always refer to unit nameplate data prior to installation

Installing Wires (High Voltage): Main Electric Supply for GT Series (compressor compartment) should enter the unit at the heat pump high voltage wiring entrance. Wire should be run through a conduit up to the cabinet and wired to the heat pump main contactor.

GT Series 024, 036, 048, 060, & 072 2-Stage Compressor with ECM Motor Wiring Diagram

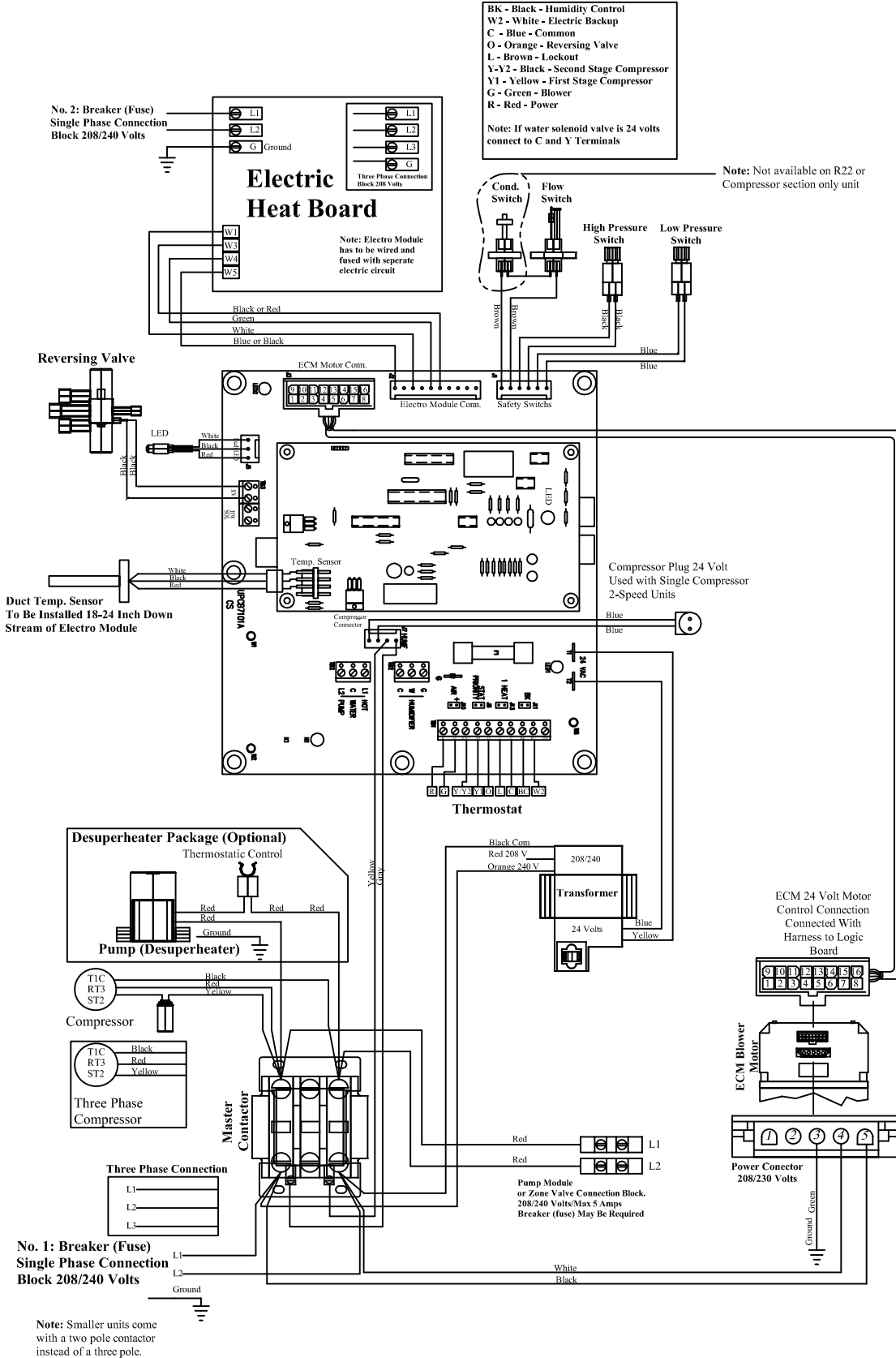

GT Series 096, 120 & 144 Dual Compressor with ECM Motor Wiring Diagram

Note: Not available on R22 or Compressor section only unit

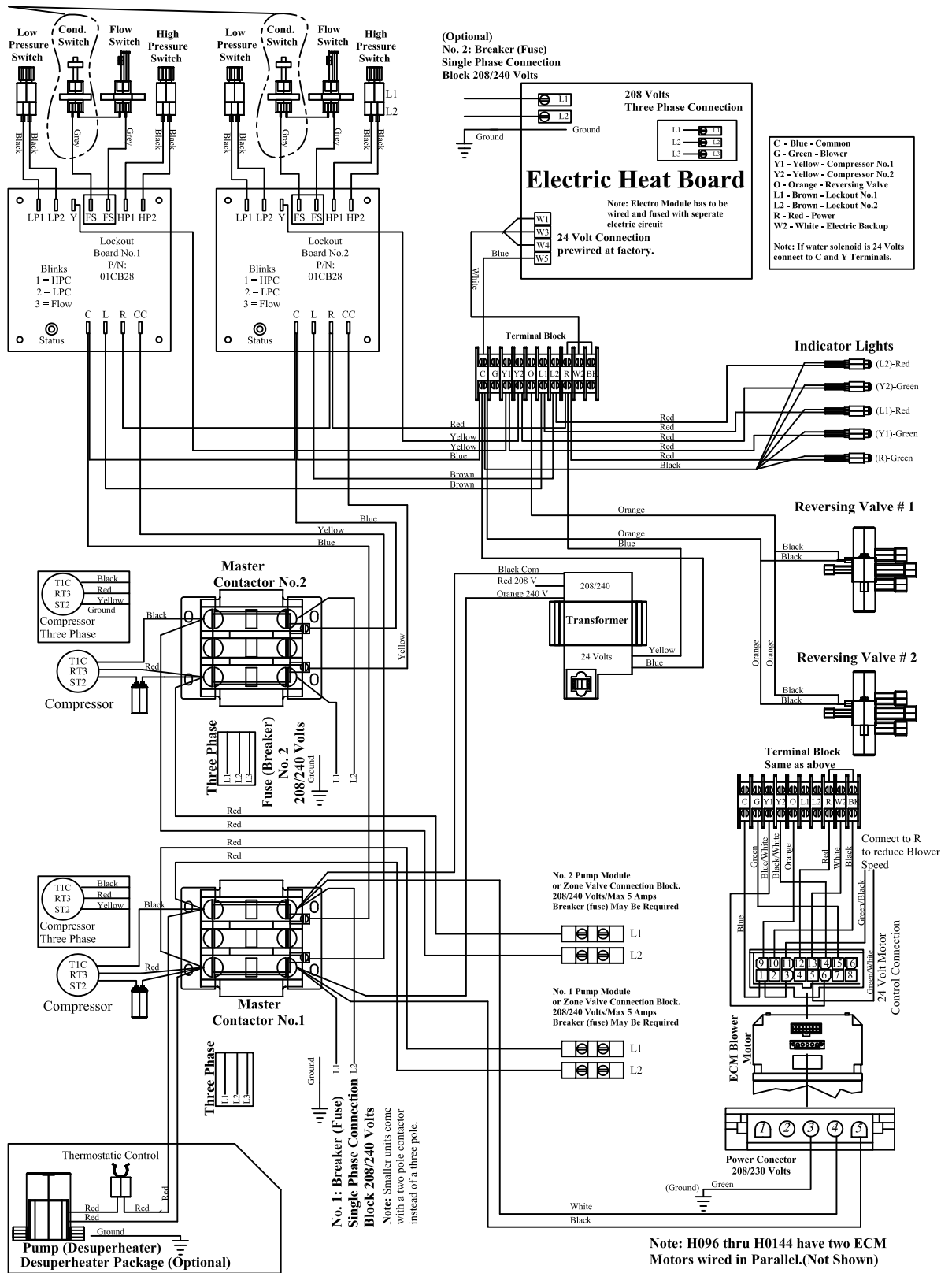

Note: H096 thru H0144 have two ECM Motors wired in Parallel.(Not Shown)

GT Series 096, 120 & 144 Dual Compressor with PSC Motor Wiring Diagram

Note: Not available on R22 or Compressor section only unit

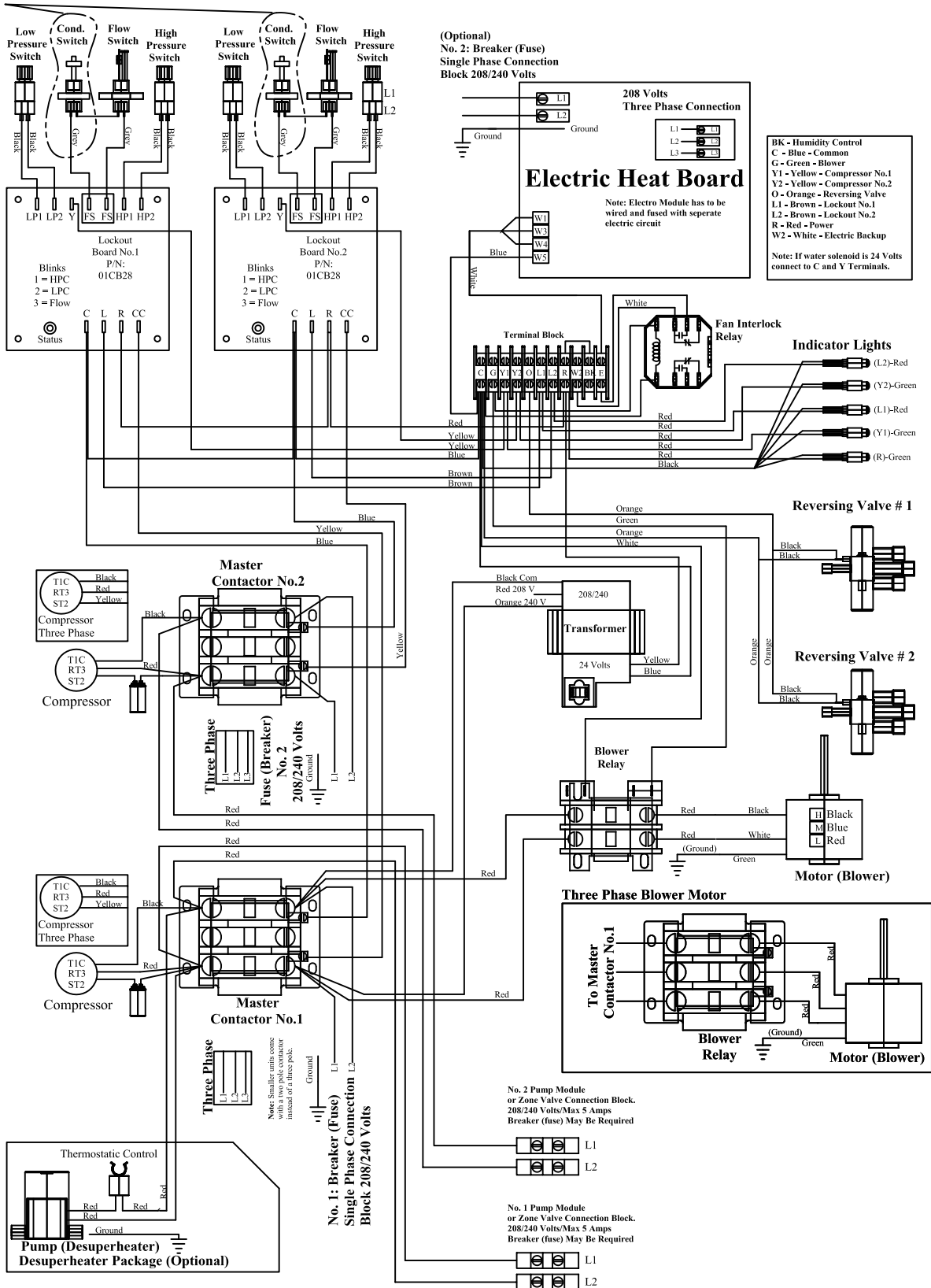

Electrical Data: Auxiliary Heater Electrical Data

| Model Number | Unit Model | kW | Volts | Amps | Minimum Circuit Size | Maximum Circuit Size | Fuse Size Amps (Inside Heater) | Minimum CFM |
|--------------|------------|----|-------|------|----------------------|----------------------|--------------------------------|-------------|
| AHTR101A | 024 - 072 | 10 | 240 | 40.0 | 50.0 | 90.0 | None | 600 |
| AHTR151A | 036 - 072 | 15 | 240 | 60.0 | 75.0 | 135.0 | 2 - 30 & 2 - 50 | 900 |
| AHTR201A | 048 - 072 | 20 | 240 | 80.0 | 100.0 | 180.0 | 4 - 50 | 1200 |

Note: 20kW heater not recommended for GT036

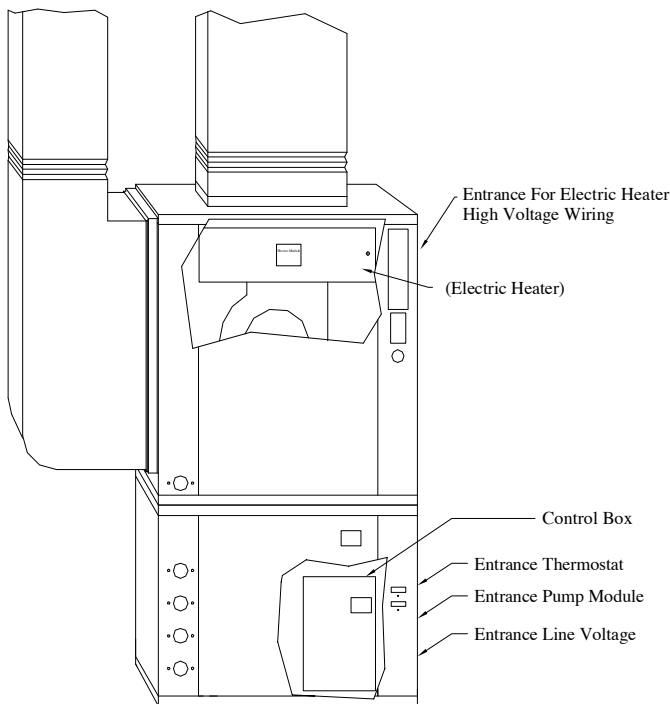

All line voltage knockouts are 1-1/8".
All low voltage knockouts are 7/8".

Installing Electric Heater High Voltage Wires:

A: Wires should enter the unit at the entrance of Electric Heater wiring entrance. Wire should be run through a conduit up to the cabinet and wired to the Electric Heater terminal strip (See wiring diagram located inside units electric box cover).

B: A separate circuit/breaker must be installed for the Electric Heater. It is not recommended to operate the Electric Heater on the same Line or Fuse (breaker) that the unit is powered.

All wiring **MUST** be done in strict compliance with local, state, national or any other applicable codes.

Note: If Electric Auxiliary is used, never disconnect power to the heat unit as it may be required to properly heat the home. Major damage may result.

Blower Data

ECM Blower

| Model | Blower Speed | CFM Nominal |
|-------|--------------|-------------|
| GT024 | High | 900 |
| | Low | 450 |
| GT036 | High | 1300 |
| | Low | 650 |
| GT048 | High | 1700 |
| | Low | 850 |
| GT060 | High | 2100 |
| | Low | 1050 |
| GT072 | High | 2350 |
| | Low | 1650 |

Note: ECM Motors will maintain a nominal CFM (approximately 400 CFM Per Ton) between .10 and .80 Static Pressure.
 Constant Fan Speed is 50% of High Speed
 Auxiliary Heat Speed is 110% of High Speed

PSC Blower

| Model | Blower Speed | CFM Nominal | Static Pressure (inches w.c.) | | | | | | | | | | |
|-------|--------------|-------------|-------------------------------|------|-----|------|------|------|------|------|------|------|------|
| | | | 0.1 | 0.15 | 0.2 | 0.25 | 0.3 | 0.35 | 0.4 | 0.5 | 0.6 | 0.7 | 0.8 |
| GT096 | High | 3200 | - | - | - | 3280 | 3250 | 3220 | 3200 | 3100 | 2950 | 2810 | 2560 |
| GT120 | High | 4000 | - | - | - | 4075 | 4050 | 4025 | 4000 | 3900 | 3700 | 3500 | 3100 |
| GT144 | High | 4500 | - | - | - | 4575 | 4550 | 4525 | 4500 | 4350 | 4100 | 3900 | 3400 |

Notes

ECM Blower Motors: Sizes 024 through 072 Models come standard with ECM Blower Motors.

PSC Blower Motors: are optional and come with 3 speed taps. To change the speed of the motor to a higher or lower speed, remove the electric box cover that is mounted on the blower. Locate the label on the motor to identify the wire color for each speed. Remove wire nut of existing speed and replace with wire of selected speed.

Operating Pressures

| Heating - Without Desuperheater | | | | | | | |
|---------------------------------|-------------|---------------------------|-------------------------|------------------|-----------------|------------------------------|-----------------------------|
| EWT (°F) | GPM Per Ton | Discharge Pressure (PSIG) | Suction Pressure (PSIG) | Sub Cooling (°F) | Super Heat (°F) | Air Temperature Rise (°F-DB) | Water Temperature Drop (°F) |
| 30 | 1.5 | 285-310 | 68-76 | 4-10 | 8-12 | 14-20 | 5-8 |
| | 3 | 290-315 | 70-80 | 4-10 | 8-12 | 16-22 | 3-6 |
| 50 | 1.5 | 315-345 | 100-110 | 6-12 | 9-14 | 22-28 | 7-10 |
| | 3 | 320-350 | 105-115 | 6-12 | 9-14 | 24-30 | 5-8 |
| 70 | 1.5 | 355-395 | 135-145 | 7-12 | 10-15 | 30-36 | 9-12 |
| | 3 | 360-390 | 140-150 | 7-12 | 10-15 | 32-38 | 7-10 |
| Cooling - Without Desuperheater | | | | | | | |
| EWT (°F) | GPM Per Ton | Discharge Pressure (PSIG) | Suction Pressure (PSIG) | Sub Cooling (°F) | Super Heat (°F) | Air Temperature Drop (°F-DB) | Water Temperature Rise (°F) |
| 50 | 1.5 | 220-235 | 120-130 | 10-16 | 12-20 | 20-26 | 19-23 |
| | 3 | 190-210 | 120-130 | 10-16 | 12-20 | 20-26 | 9-12 |
| 70 | 1.5 | 280-300 | 125-135 | 8-14 | 10-16 | 19-24 | 18-22 |
| | 3 | 250-270 | 125-135 | 8-14 | 10-16 | 19-24 | 9-12 |
| 90 | 1.5 | 360-380 | 130-145 | 8-14 | 10-14 | 18-22 | 17-21 |
| | 3 | 330-350 | 130-140 | 8-14 | 10-14 | 18-22 | 8-11 |

01CB30 Board Control Feature and Operation, For Two Speed Units With ECM Technology,

The G Series, Logic Controlled System

(01CB30) is a microprocessor-based printed circuit board. It is located in the unit control box for convenient accessibility. This control board is specially design for the G series units which integrate the ECM blower motor. The microprocessor provides control of the entire unit as well as outputs for status modes, faults and diagnostics. A LED is located on front corner of the unit for quick inspection without removing any access panels.

Low voltage strip provide all necessary terminal for field installations. The board accepts standard 24VAC Thermostat inputs.

Startup

The unit will not operate until all inputs and safety controls are checked for normal conditions.

Fault Retry & Diagnostics

All faults are retried three times, with 5 minute delay between each attempt, before finally locking the unit out. An output signal (L) is made available for a fault LED at the thermostat. The “fault retry” feature is designed to prevent nuisance service calls.

Safety Controls

The G Series control receives separate signals for a high pressure switch for safety, a low pressure switch to prevent loss/low refrigerant charge damage & a flow switch for freeze protection.

Fan Speed Control

The BK terminal on the G series board allows field speed reduction of 15% blower speed for cooling in the dehumidification mode.

Flow Switch (Freeze Protection) Operation

When the 24vac is applied to the Y/Y2 or Y terminal, the control is monitoring the flow switch input. If the flow switch opens (no water flow), the control board will energize the compressor contractor, and start the compressor, after the random start is over. If the flow switch is still open after the 30 seconds, the control will de-energize the compressor contractor. The control board won't start the sequence unless the flow switch closes. If the flow switch opens while the compressor is energizes, the control board will energize the compressor contractor for a minimum time period of 30 seconds, after 30 seconds, the control board will de-energize the compressor contractor and go into a soft lockout. The control board will not energize the compressor contractor unless the flow switch closes and the anti-short cycle time has expired. If the flow switch opens three times with-in 1 hour, the control board will go into manual lockout and the fault indicator will energize. When the flow switch is open, or if in lockout mode, the status led on the control board will blink, three times.

Condensation Overflow Protection

The G Series units come standard with a condensation sensor. If sensor is sensing condensation liquid the compressor will shut down and the flow status light will blink, three times.

G Series Microprocessor driven Logic Control Board

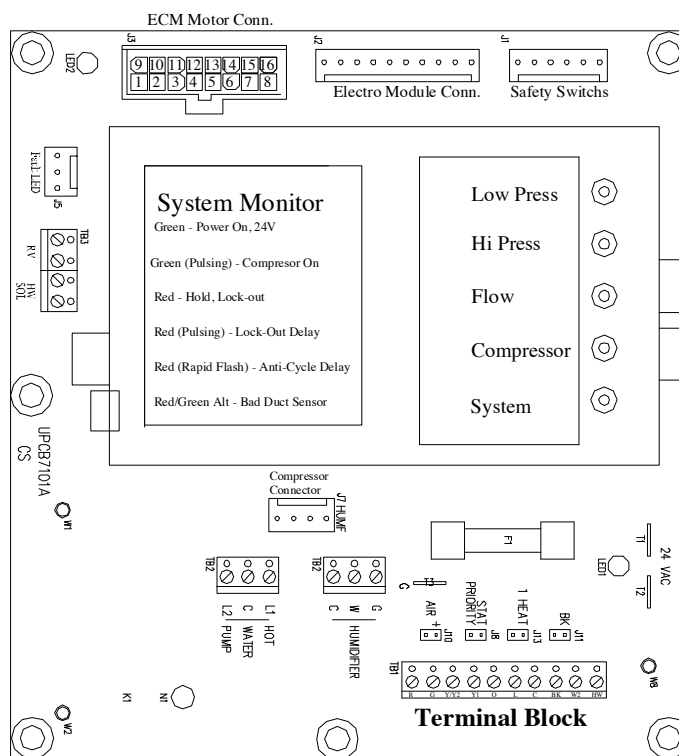

Anti-Short Cycle Operation

If all safety controls are satisfactory, the compressor contractor will energize when the control board receives 24VAC on the thermostat input “Y/Y2 or Y1” terminal. If the 24VAC on the “Y/Y2 or Y1” terminal is removed, the control board will de-energize the compressor contractor and go into a 300 second lockout. If the 24VAC is reapplied to the “Y/Y2 or Y1” terminal again, the control board will not energize the compressor contractor until after the 300 second lockout is over.

High & Low Pressure Safety Operation

When the 24vac is applied to the “Y/Y2 or Y1” terminal, the control board is monitoring the high & low pressure switch input to make sure that they are closed. The control board won't start the sequence unless the high & Low pressure switch are closed. If the high & low pressure switch opens while the compressor contractor is energized, the control will de-energize the compressor contractor and go into a soft lockout. The control board will not energize the compressor contractor unless the high or low pressure switch closes and the anti-short cycle time has expired. If the high or low pressure switch opens three times with in 1 hour, the control board will go into manual lockout and the fault contact will energize. When the high or low pressure switch opens or if in lockout

01CB30 Board Control Physical Layout

Back Board

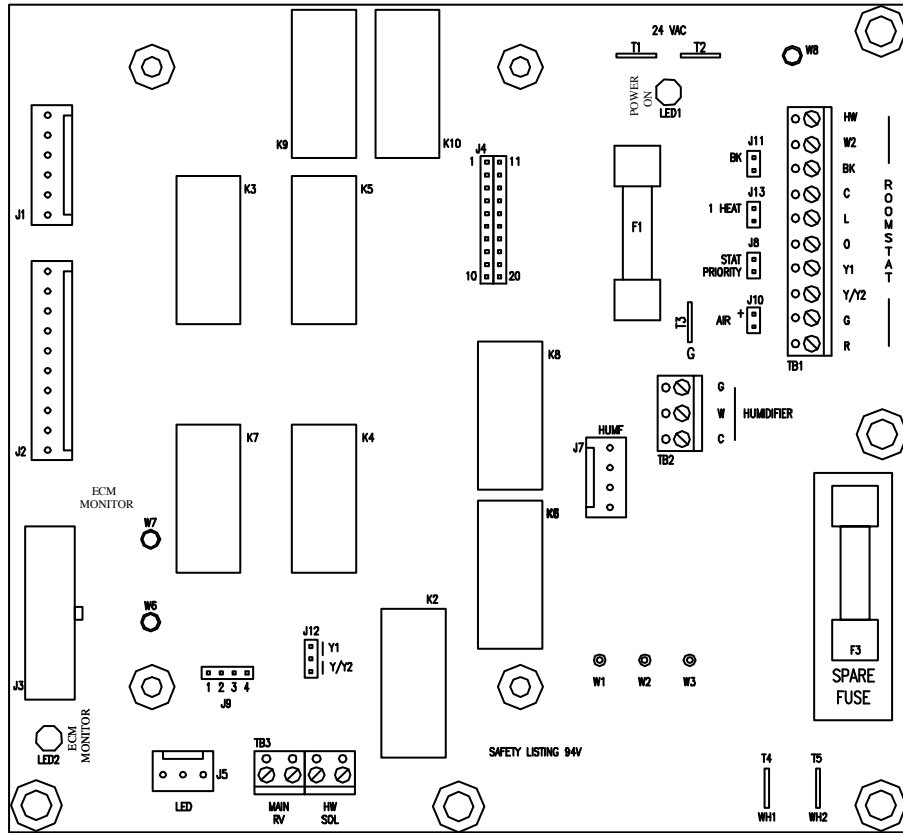

Top Board

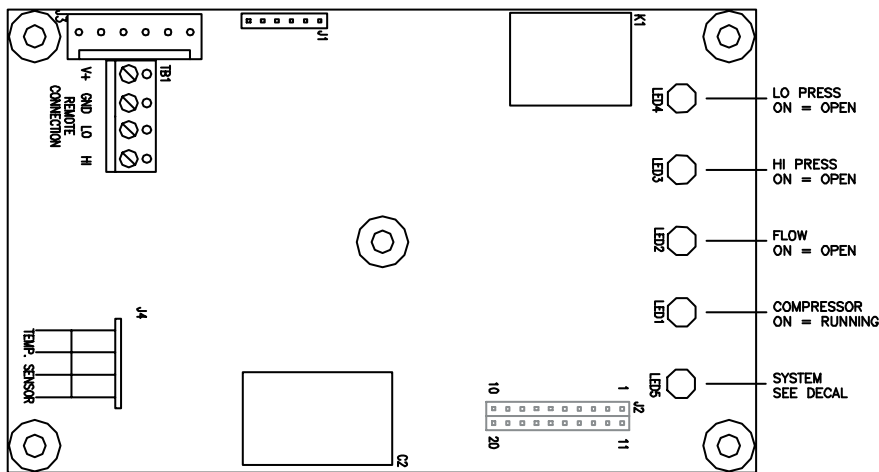

Plenum Temperature Sensor

Plenum temperature sensor should be installed 18" to 24" above (or from) the Electro Module Elements. Stage 1 is a direct function of W2 stat input only. The controller has the ability to interrupt or deactivate stage 2 and stage 3. Sensor must be enabled, to function by connecting means of software to the board data port. For more information on sensor see your Electro Module PC software manual.



Controls Sequence of Operation

Setup – Palm/PC

Factory can change any number or delays for convenience of checkout, trouble shooting, and temperatures. Also stored on board, fault history troubleshooting.

Control Board Lockout Functions

High and Low Pressure switches, only create Soft Lockout mode.

Jumper Setup

J8 = stat priority – “Y” is priority over HW terminal if jumper is installed.

J9 = ECM jumpers - relates to specific models. Can also be used to lower motor speed.

J10 = Air+ - Change the continuous fan speed “G” call (50%) to 65 % continuous air, if jumper is installed.

J11 = BK - Cooling only, If jumper is installed fan is running at normal speed, When a humidistat is connected to BK terminal remove jumper. When humidistat calls, (0 volts at BK terminal) fan will reduce speed by 15%.

J12, selects single speed or dual speed compressor (three posts, two positions) - jumper installed at Y/Y2 sets up standard single stage stat where “basic Y” is connected to

Y/Y2 screw. Jumper installed at Y1 set up Y1 input as first stage stat where “basic Y or Y1 on thermostat” is connected on Y1 screw. Jumper set at Y1 requires a 2 Heat/2 Cool thermostat and if Backup installed a 3 Heat/2 Cool Thermostat.

J13, 1 HEAT – Heating mode only, with pin jumper installed, Y1 activates both compressor speed 1 and speed 2. Stat Y/Y2 basically has no function (heat only).

Heating Operation

Heat, 1st stage (Y/Y1)

The fan motor is started on low speed immediately, the loop pump is also started at the Y/Y1 call, and the compressor is energized at low capacity. The fan motor speed is changed to 70% in 30 seconds, after Y call.

Heat, 2nd stage (Y & W2) Single Capacity Units

The second stage heat is energized. The fan motor speed is changed to 100% after W2 calls. After 10 Minutes of continuous W2 Call, and plenum temperature is not at max, the fan motor will change to 110%.

Heat, 2nd stage (Y1 & Y2) Dual Capacity Units

The second stage heat is energized. The fan motor speed is changed to 85% after Y2 calls.

Heat, 3rd stage (Y1, Y2 & W2) Dual Capacity Units

The third stage heat is energized. The fan motor speed is changed to 100% after W2 calls. After 10 Minutes of continuous W2 Call, and plenum temperature is not at max, the fan motor will change to 110%.

Emergency Heat (W2 Only)

The fan motor is started on high speed, and the first stage heat is energized. 10 second after continuous demand the addition stages of resistance heat will sequence to desired temperature, (if temperature sensor is installed).

Cooling Operation

In cooling mode the O terminal (reversing valve) is always energized.

Cool, 1st stage (Y, O or Y1, O) Dual Capacity Units

The fan motor is started on low speed immediately, the loop pump is also started at the Y1 call, and the compressor is energized at low capacity. The fan motor speed is changed to 70% in 30 seconds, after Y1 call.

Cool, 2nd stage (Y1 & Y2) Dual Capacity Units

The second stage cool is energized. The fan motor speed is changed to 85% and after 15 seconds to 100% (85% if Humidistat calls), after Y2 calls.

Humidifier Terminal Strip

The G Terminal allows a direct 24 volt signal (from the thermostat G terminal) if the O is not energized. The W terminal allows a direct 24 volt signal (from the thermostat Y terminal) if the O is not energized. Both G & W are de-energized when the O terminal represents cooling.

Fan (G Only)

The “G” terminal starts the fan at low speed. Regardless of the fan input “G” from thermostat, the fan will remain on low speed for 30 seconds at the end of each heating, cooling or emergency heat cycle.

Indicator LEDs

Top Board, Controller & External (outside) Corner System - red and green color with various combinations.

Green = on solid - power-on, ready or no t-stat call.

Pulsing - compressor relay on.

Red = pulsing - in lockout mode.

On solid - in lockout hold mode.

Fast pulsing - in anti-cycle delay (ACD).

Green/red = alternating - detected bad temperature sensor or not plugged in.

Top Board, Controller

Compressor: Yellow = On indicates voltage to compressor contactor coil.

Flow: Red = on indicates no flow. If there's no t-stat call, LED is on representing no flow.

High Pressure: Red = on indicates open. Momentary open declares lockout hold (set at 600 PSI).

Low Pressure: Red = on indicates open. Momentary open declares lockout hold (Set at 40 PSI).

L Fault LED (Thermostat)

Pulsing = in lockout mode or bad temperature sensor.

01CB28 Lockout Board Control Feature and Operation, For Single Speed & Dual Compressor Units

The G Series Logic Controlled System

(01CB28) is a microprocessor-based printed circuit board. It is located in the unit control box for convenient accessibility. This control board is specially design for the G series units. The Board provides control of the unit as well as outputs for status modes, faults and diagnostics.

Startup

The unit will not operate until all inputs and safety controls are checked for normal conditions.

Fault Retry & Diagnostics

All faults are retried three times, with 5 minute delay between each attempt, before finally locking the unit out.

- 1 Blink for high pressure switch
- 2 Blinks for low pressure switch
- 3 Blinks for flow switch

Safety Controls

The G Series control receives separate signals for a high pressure switch for safety, a low pressure switch to prevent loss refrigerant charge damage & a flow switch for freeze protection.

Testing

The G Series control allows service personal to shorten timing delays for fast diagnostics. If jumper is set to no positions, timing is set to standard, If jumper is set to yes position; timing is reduced for service and startup.

Flow Switch (Freeze Protection) Operation

When the 24vac is applied to the y terminal, the control is monitoring the flow switch input. If the flow switch opens (no water flow), the control board will energize the compressor contractor, and start the compressor, after the random start is over. If the flow switch is still open after the 30 seconds, the control will de-energize the compressor contractor. The control board won't start the sequence unless the flow switch closes. If the flow switch opens while the compressor is energizes, the control board will energize the compressor contractor for a minimum time period of 30 seconds, after 30 seconds, the control board will de-energize the compressor contractor and go into a soft lockout. The control board will not energize the compressor contractor unless the flow switch closes and the anti-short cycle time has expired. If the flow switch opens three times with-in 1 hour, the control board will go into manual lockout and the fault indicator will energize. When the flow switch is open , or if in lockout mode, the status led on the control board will blink, three times.

Condensation Overflow Protection

The G Series units come standard with a condensation sensor. If sensor is sensing condensation liquid the compressor will shut down and the flow status light will blink, three times.

G Series Logic Control Board

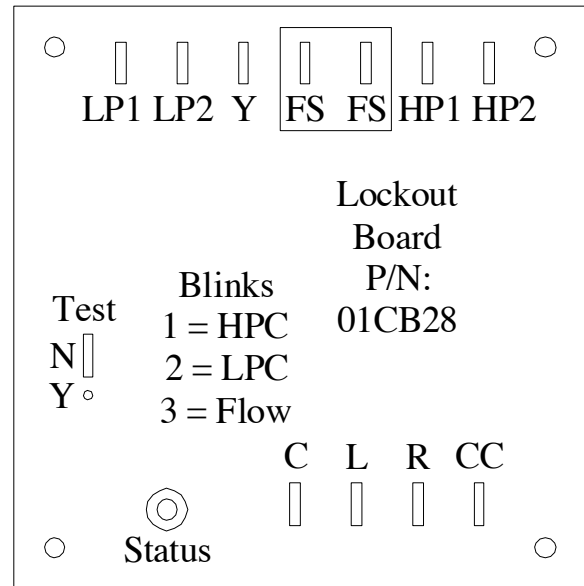

LP1 - Low Pressure
LP2 - Low Pressure
Y - H/C Call
FS - Flow Switch
FS - Flow Switch
SS - Contactor

HP1 - High Pressure
HP2 - High Pressure
C - Common
L - Fault
R - Power

Anti-Short Cycle Operation

If all safety controls are satisfactory, the compressor contractor will energize when the control board receives 24VAC on the thermostat input "y" terminal. If the 24VAC on the "y" terminal is removed, the control board will de-energize the compressor contractor and go into a 300 second lockout. If the 24VAC is reapplied to the "y" terminal again, the control board will not energize the compressor contractor until after the 300 second lockout is over.

High & Low Pressure Safety Operation

When the 24vac is applied to the "y" terminal, the control board is monitoring the high & low pressure switch input to make sure that they are closed. The control board won't start the sequence unless the high & Low pressure switch are closed. If the high & low pressure switch opens while the compressor contractor is energized, the control will de-energize the compressor contractor and go into a soft lockout. The control board will not energize the compressor contractor unless the high or low pressure switch closes and the anti-short cycle time has expired. If the high or low pressure switch opens three times with in 1 hour, the control board will go into manual lockout and the fault contact will energize. When the high or low pressure switch opens or if in lockout mode, the status led on the control board will board will blink, one for high & two for low pressure switch.

Engineering Specifications

General

The Geothermal Heat Pump system and the earth loop shall be one system and include all interconnecting piping and controls to provide an efficient, harmoniously balanced package. All units shall be tested and rated by ETL in accordance with UL and CSA test laboratory safety and performance standards. Each unit shall be computer run-tested at the factory. Each unit shall be mounted on a pallet and shipped in a corrugated box. Units shall be designed to operate with entering liquid temperature between 25°F and 110°F.

Refrigerant Circuit

Compressor shall be hermetically sealed high efficient scroll, mounted on vibration isolators. The air heat exchanger (coated) coil shall use high-density technology, low-face velocity and incorporate enhanced aluminum fins bonded to copper tubing not less than three rows deep. The coaxial water heat exchanger shall be designed for low water pressure drop and constructed of an optional cupro-nickel or standard copper inner tube and a steel outer tube with enhanced heat exchanger surface. An optional domestic water desuperheater coil of vented double wall copper construction for potable water with high limit control shall be employed. The thermostatic expansion device shall be bi-directional, mechanical controlled and shall provide proper superheat over the entire liquid temperature range with minimal hunting. The reversing valve shall be of copper construction with a 24V AC solenoid valve with fail-to-heating position.

Cabinet

The cabinet shall be of heavy gauge steel. It shall be bolted together and incorporate a condensate pan and be installed with high-density insulation, with smoke and flame spread of class 1 type and acoustic value of NRC .45. It shall be oriented to allow complete component service access from all sides. Electrical box shall be of heavy gauge steel located on the access panel side of the cabinet. A duct collar shall be provided on the supply air opening and a return air filter, rack & duct collar shall be provided on the return air opening. Standard size 1-inch filters shall be provided with each.

Controls and Blower Motor

Units shall incorporate a microprocessor based control board. All equipment shall incorporate both high and low pressure switches and freeze protection with total refrigerant circuit lockout with manual reset. The board shall provide a terminal block, LED status, fault indicators, fault memory and accessory output. All units shall have knockouts for entrance of line & low voltage wiring.

Fan Motor & Assembly.

The fan shall be a direct driven type. The motor shall be a variable-speed ECM or optional high efficiency PSC motor with direct driven or belt driven blowers that can be easily removed from the heat pump without duct disconnection. The ECM fan motor shall be soft starting and maintain constant CFM over its operating static pressure range. The fan motor shall be isolated from the housing by rubber grommets. The ECM motors shall be long life ball bearing type. The PSC motor shall be thermostatic overload protection and to have permanently lubricated.

Piping & Connections

Loop water connections (supply/return) shall be 1-inch FPT brass swivel connection, which provide a union for easy connection. Larger fitting shall be female copper (1¼ to 1½) connection. All water piping shall be insulated to prevent condensation at low water temperatures. The condensation connection shall be ¾" female brass connection.

Hanger Kit (for field installed horizontal units)

The hanger kit shall consist of galvanized steel brackets, isolators, bolts & lock washers. Bracket shall be designed to fasten to the unit's bottom cabinet and be connected to ceiling with 3/8" threaded rod. Units size 024 shall include four brackets and units sizes 036-060 shall include six brackets

Secondary Drain Pan.

A secondary drain pan should be field furnished and installed under the unit, on horizontal unit or any other unit that is mounted overhead in an attic, second floor

Options, Accessories, & Warranty

Desuperheater

Optional desuperheater package of vented double wall copper constructed heat exchanger coil suitable for potable water shall be provided. The heat exchanger and hot water circulating pump shall be factory installed inside the cabinet.

Field Installed Hydronic Pump Module (Flow Center)

Pump module shall be self contained and provide all liquid flow, liquid fill and connection required for earth loop system. The pumps shall be wired to the pump terminal strip inside unit electric box.

Field Installed Thermostat

A multiple-stage manual or autochangeover electronic/digital thermostat shall be provided with the unit. The thermostat shall provide two or three stage heating and one or two stage cooling with comfort temperature control. An AUTO-OFF fan switch, an EMERG-HEAT OFF- COOL-AUTO system switch, and indicating LEDs. The thermostat shall provide display in °F or °C. An option remote outdoor sensor shall be available.

Field Installed Electric Auxiliary Heater

An Electric resistance heater shall provide emergency and/or supplemental heating. Vertical unit shall have the control console and element (coils) assembly mounted internally. Horizontal units shall have the control board and elements (coils) assembly mounted inside on end discharge units and on side discharge the control board shall be mounted inside while the elements (coils) assembly should be mounted outside the cabinet. The heater shall provide operation control based upon signals from the thermostat or compressor section controls. A Low Voltage wiring harness shall be provided with electric heat package.

Zone Control System

Call your Factory representative for information on Zoning.

Warranty

Residential Class Equipment

Enertech Manufacturing, LLC warrants the REFRIGERANT SYSTEM, to include the compressor, condenser, evaporator, expansion valve, and reversing valve, to be free from defect in material and workmanship for a period of TEN (10) YEARS FROM THE DATE OF INSTALLATION.†

Enertech Manufacturing, LLC warrants its GEOTHERMAL UNIT against defect in materials and workmanship for FIVE (5) YEARS FROM THE DATE OF INSTALLATION.†

Enertech Manufacturing, LLC warrants SERVICE LABOR ALLOWANCES for TWO (2) YEARS FROM THE DATE OF INSTALLATION† for servicing, removing, or reinstalling parts for the refrigerant circuit, steel cabinets or for any defect in materials and workmanship as set forth above.

† Warranty start date will be delivery date unless proof of startup (no later than 90 days after invoice) is presented. All warranties must be purchased within 90 days of invoice. For unoccupied spec homes, extended warranty may be purchased within 360 days of invoice. Warranty commences at startup date.

Revision Table

| Date: | By: | Page: | Description: |
|----------------|-----|-------|-------------------------------------|
| 08 Oct, 2008 | DS | 44-47 | Updated Wiring Diagrams |
| 08 Oct, 2008 | DS | 41 | Updated Vertical Dimensional Data |
| 08 Oct, 2008 | DS | All | Added GT072 Model Information |
| 08 Oct, 2008 | DS | All | Discontinued GT074 Models |
| 22 May, 2008 | DS | 7 | Corrected Flow Calculation Examples |
| 29 April, 2008 | DS | All | Minor Formatting Corrections |
| 11 April, 2008 | DS | All | First Published |

GeoComfort[®]

Geothermal Systems

2506 South Elm Street
Greenville, IL 62246
www.geocomfort.com

(888)-436-3783
(618)-664-9010
Fax: (618)-664-4597



Enertech Manufacturing is continually working to improve its products. As a result, the design and specifications of each product may change without notice and may not be as described herein. For the most up-to-date information, please visit our website, or contact our Customer Service department at (618)-664-9010. Statements and other information contained herein are not express warranties and do not form the basis of any bargain between the parties, but are merely Enertech Manufacturing's opinion or commendation of its products.