

SUBMITTAL INFORMATION

Curb Boxes - (EA2-xx-40-xxR style)

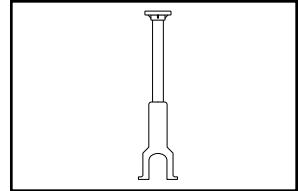

ARCH PATTERN - 1" UPPER SECTION - PLUG STYLE LID - WITH STATIONARY ROD

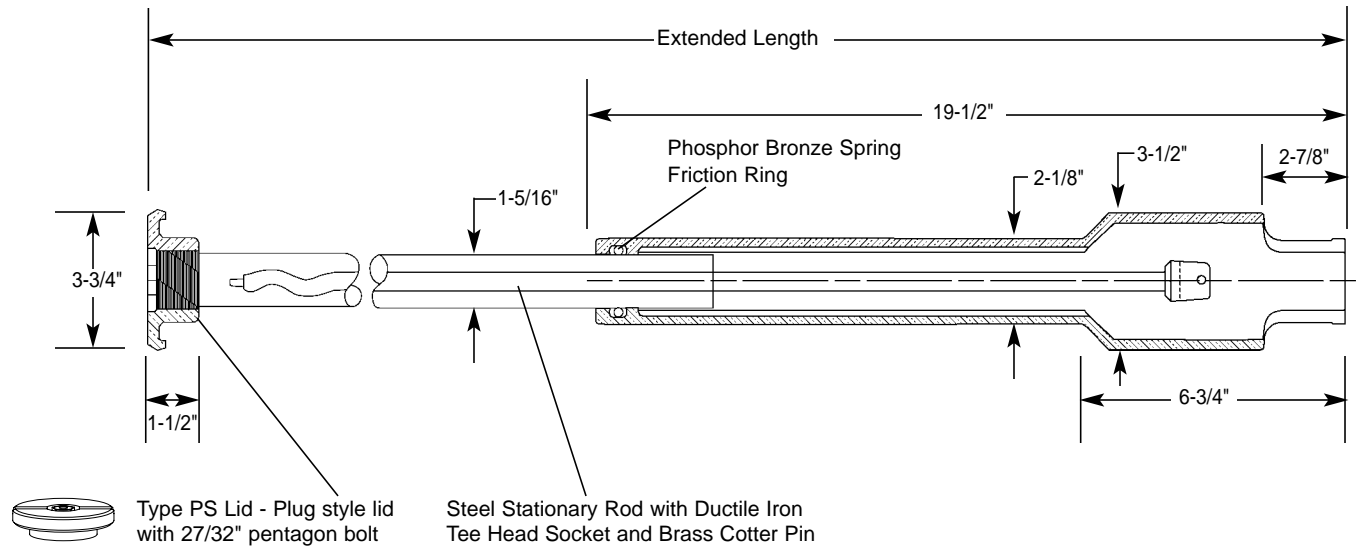

*EXTENDED LENGTH	ROD LENGTH	APPROX. WT. LBS.	CATALOG NUMBER	✓ SUBMITTED ITEM(S)
3'	18"	16	EA2-30-40-18R	
3'-6"	24"	17	EA2-35-40-24R	
4'	30"	19	EA2-40-40-30R	
4'-6"	36"	20	EA2-45-40-36R	
5'	42"	21	EA2-50-40-42R	
5'-6"	48"	22	EA2-55-40-48R	
6'	54"	24	EA2-60-40-54R	
6'-6"	60"	25	EA2-65-40-60R	
7'	66"	26	EA2-70-40-66R	
7'-6"	72"	27	EA2-75-40-72R	
8'	78"	28	EA2-80-40-78R	
9'	84"	30	EA2-90-40-84R	

*Telescopes to 1 foot less than extended length.

FEATURES

- Arch base for use with Curb Stops in sizes 1" and smaller.
- Adaptable to 1-1/4", 1-1/2" and 2" Curb Stops by placing on the CB-7 Curb Box Base.
- Lid and Base made of Cast Iron per ASTM A48, Class 25.
- Brass plug conforms to AWWA Standard C800 (ASTM B-62, UNS No C83600 - 85-5-5-5).
- Upper Section made of Steel.
- Painted Black Asphalt.

The Ford Meter Box Company considers the information in this submittal form to be correct at the time of publication. Item and option availability, including specifications, are subject to change without notice. Please verify that your product information is current.



The Ford Meter Box Company, Inc.

P.O. Box 443, Wabash, Indiana U.S.A. 46992-0443

Phone: 260-563-3171 / Fax: 800-826-3487

Overseas Fax: 260-563-0167

<http://www.fordmeterbox.com>

04/30/02

Submitted By: