

<b>JOB:</b>  <b>UNIT TAG:</b> <b>ENGINEER:</b> <b>CONTRACTOR:</b>	<b>REPRESENTATIVE:</b>  <b>ORDER NO.</b> <b>SUBMITTED BY:</b> <b>APPROVED BY:</b>	<b>DATE:</b> <b>DATE:</b> <b>DATE:</b>
---	---	--

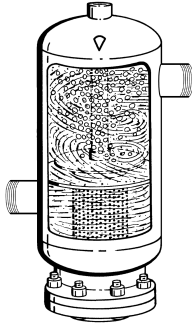
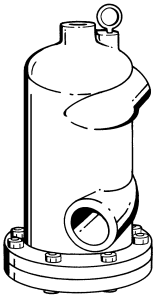

# ROLAIRTROL<sup>®</sup>

## Air Separator

NPT With Strainer  
Air Control and Elimination

**DESCRIPTION**

The Rolairtrol Air Separator is an ASME vessel designed with tangential openings to create a low velocity vortex where air is separated and removed from the circulating water.

**MAXIMUM WORKING PRESSURE**

125 PSIG (862 kPa)

**OPERATING TEMPERATURE RANGE**

-20°F (-29°C) to +350°F (177°C)

**CONSTRUCTION MATERIALS**

- | Designed and constructed per ASME Section VIII, Division 1
- | Body – Models R-2 & R-2-1/2: Cast Iron
- | Shell – Models R-3: Carbon Steel
- | System Strainer: Models R-2 & R-2-1/2: Galvanized Steel with 3/16" (4.8mm) diameter perforations and 51% open area
- | System Strainer: Model R-3: 304 stainless steel with 3/16" (4.8 mm) diameter perforations and 51% open area
- | Air Collector Tube: Stainless steel with 5/32" (4mm) diameter perforations and 63% open area
- | Baffle/Collector Tube Support Assembly: Carbon Steel
- | Bottom Reducing Flange Gasket: Armide fiber

**SCHEDULE**

PART NUMBER	MODEL NUMBER	Capacity GPM (m <sup>3</sup> /hr)	NPT Tangential Opening in. (mm)	TAGGING INFORMATION	QUANTITY
5360-02N-12-001	R-2N	56 (12.7)	2 (50.8)		
5360-25N-12-001	R-2-1/2N	90 (20.4)	2-1/2 (63.5)		
5360-03N-12-003	R-3N	190 (43.2)	3 (76.2)		
5360-03N-12-004	R-3NB	190 (43.2)	3 (76.2)		

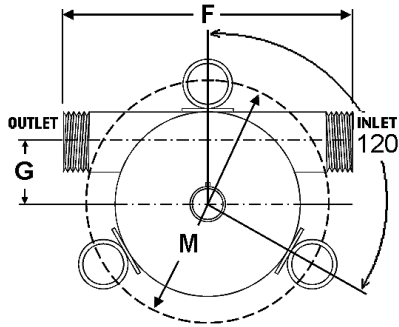
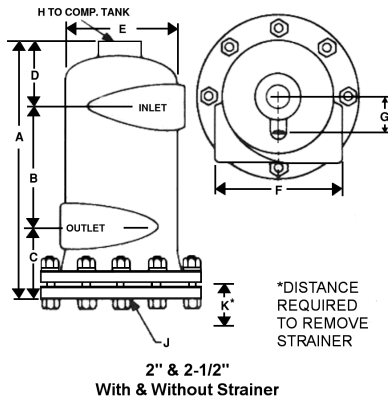

3" MODELS WITH STRAINER AND OPTIONAL BRACKET SUPPORTS

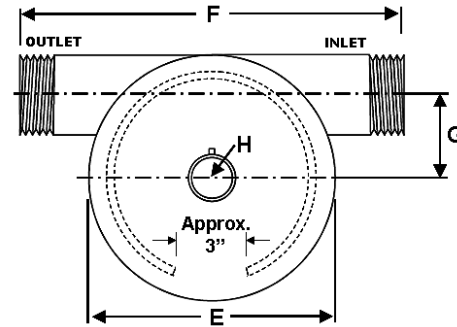
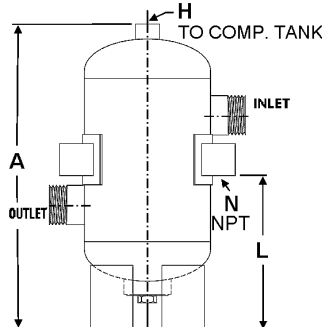

3" MODELS WITH STRAINER

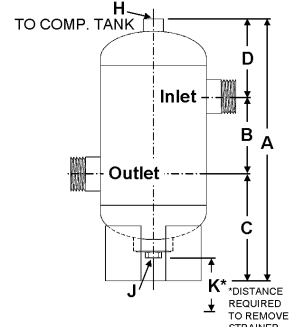

DIMENSIONS in Inches (mm) AND WEIGHTS in Lbs (kg.)

MODEL NUMBER	A	B	C	D	E	F	G	H	J	K	Cv	Strainer Free Area in in <sup>2</sup> (mm <sup>2</sup> )	Approx. Volume in Gallons (Ltr.)	Approx. Shpg. Wt. in Lbs. (Kg)	Flood Wt. Less Bracket in Lbs. (Kg)
R-2N	15-7/8 (403)	7 (179)	4 (102)	4-7/8 (124)	6-5/8 (168)	7-3/8 (187)	2 (51)	1 (25)	1 (25)	8-1/2 (216)	44	32 (20,645)	2 (7.6)	55 (25)	70 (32)
R-2-1/2N	17-3/8 (441)	7-1/2 (191)	4-1/2 (114)	5-3/8 (137)	8-3/8 (213)	9-3/4 (248)	2-5/8 (67)	1 (25)	1 (25)	8-1/2 (216)	64	45 (29,032)	3 (11.4)	90 (41)	115 (52)
R-3N (B)	26-7/8 (683)	8 (203)	10-13/16 (275)	8-1/16 (205)	10-3/4 (273)	16-3/4 (426)	3-5/8 (92)	1-1/4 (32)	3 (76)	12 (305)	80	66 (42,581)	7 (26.5)	95 (43)	155 (70)

Important Note: Dimensions not to be used for construction.

SUPPORT NOTES:

1. Model "R" Rolairtrol Air Separators have strainers which must be removed and cleaned after 24 hours operation, 30 days operation and as required to maintain proper system air separation. Before installing the model "R" Rolairtrol, refer to (K) in the dimensions and weights table, which notes minimum distances to be maintained between the blowdown connection and the floor or other equipment for strainer removal.
2. Lifting lugs are for the transportation and installation of the empty vessel, and are not to be used for complete or partial support of the flood vessel.
3. The RL skirt can support flooded vessel weight, but an R model bottom flange (strainer housing) cannot support the flooded weight of the vessel.
4. Welding to the pressure vessel boundary will void the ASME stamp.
5. Standard Rolairtrol design up to 12" can be hung from the nozzles using hangers. Optional, factory welded, support brackets are available for an additional cost.

MODEL NUMBER	L	M	N	Weights of Brackets
RL-3NB	13-3/8 (340)	14 (356)	2 (51)	9 (4)

MODEL NUMBERING

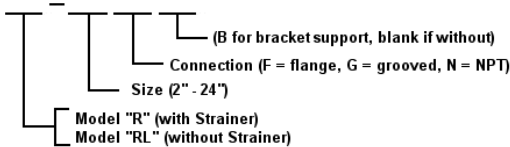

R MODELS (WITH STRAINER)

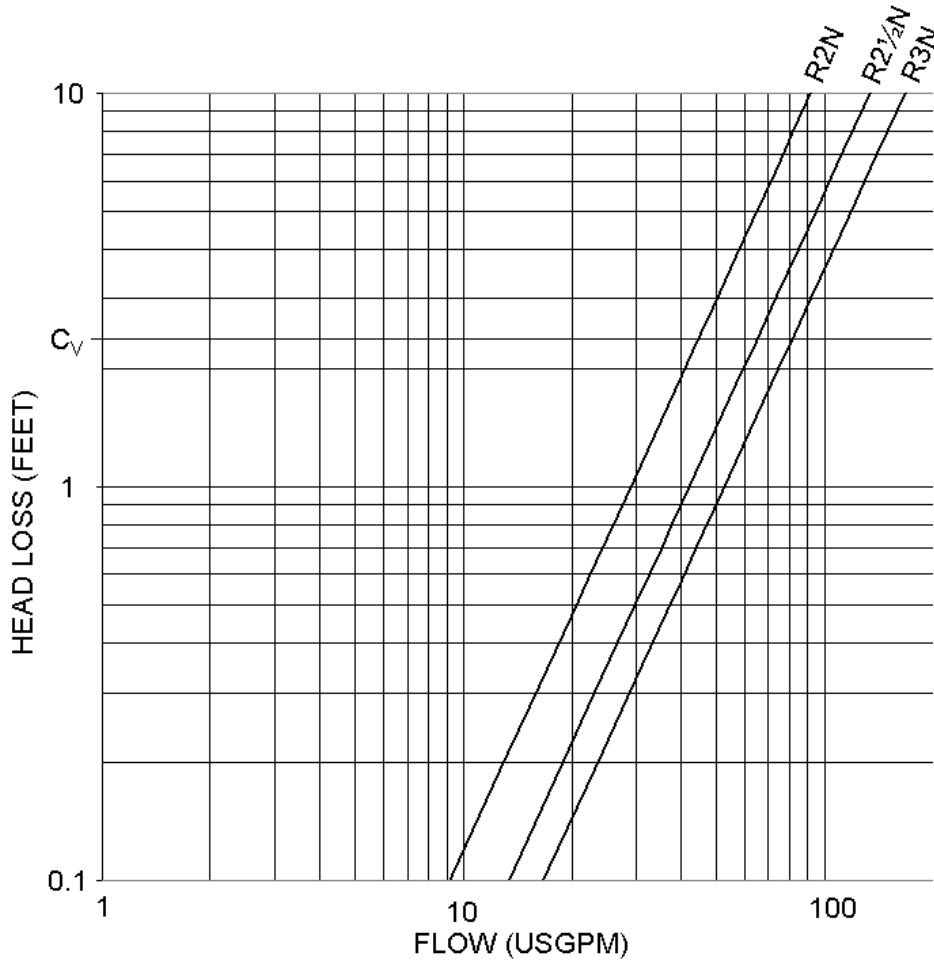

**Note:** Pressure drops for a range of flow are indicated on this chart. Users should select Rolairtrol using B&G published capacity guidance, and ASHRAE pipe sizing recommendations for optimal performance.

**TYPICAL ROLAIRTROL SPECIFICATIONS**

Furnish and install, as shown on plans, a centrifugal type air separator. The unit shall have \_\_\_\_ " inlet and outlet NPT connections tangential to the vessel shell. The unit shall have an internal stainless steel air collector tube with 5/32" (4mm) diameter perforations and 63 percent open area designed to direct accumulated air to the compression tank (air control system) or air vent (air elimination system) via an NPT vent connection at top of unit.

The unit shall have a removable galvanized steel/304 stainless steel system strainer with 3/16" (4.8mm) diameter perforations and a free area of not less than five times the cross-sectional area of the connecting pipe. The strainer shall be located at the bottom of the vessel to reduce floor space required for strainer removal.

A blowdown connection shall be provided to facilitate routine cleaning of the strainer and the separator. Specify B&G Model MBV-1 Rolairtrol accessory for manual blowdown.

**Refer to submittal A-329 for information on the MBV-1 manual blowdown valve.**

Vessel shell diameter to be three times the nominal inlet/outlet pipe diameter, with a minimum vessel volume for sufficient velocity reduction.

The air separator must be designed, constructed and stamped for 125 psig @ 375°F (862 kPa @ 191°C) in accordance with Section VIII, Division I of the ASME Boiler and Pressure Vessel Code, and registered with the National Board of Boiler and Pressure Vessel Inspectors. The air separator(s) shall be painted with one shop coat of light gray air dry enamel.

A manufacturer's Data Report for Pressure Vessels, Form U-1 as required by the provisions of the ASME Boiler and Pressure Vessel Code, shall be furnished for each air separator upon request.

Each air separator shall be ITT Bell & Gossett Model No. \_\_\_\_ Rolairtrol Air Separator for \_\_\_\_ GPM ( \_\_\_\_ m<sup>3</sup>), Shell Dia. \_\_\_\_" ( \_\_\_\_ mm) and Min. Vessel Volume \_\_\_\_ Gal ( \_\_\_\_ liters).

