

Hub 3.0 Specifications

Application

The LeakSmart® Hub 3.0 is a smarter, more flexible, and disaster proof system hub that communicates between sensors, the cut-in valve or valve controller, and you. New built-in WiFi now frees the hub from being installed next to your router. Place it anywhere you like in the home for optimal coverage and strengthened communication between devices. Built-in re-chargeable battery works even if power goes out. Latest Zigbee 3.0 protocol ensures it works even if WiFi is down.

Features

- Supports Zigbee Networking
- Battery back-up
- AC power
- LED status lights
- Supports one valve, multiple sensors and two range extenders - up to 32 devices
- 5-year manufacturer's warranty*

Product Specifications

- Frequency:** 2405 to 2480 MHz
- Operating Voltage:** 110 to 240 VAC
- Operating Temperature:** -22°F - 158°F (-30°C to 70°C)
- Power Adapter:** 6'
- Input AC Voltage:** 110 to 240 VAC, 50/60 Hz
- DC Output:** 5 Volt
- Battery:** Lithium NI18350A

Materials

High performance engineered polymer

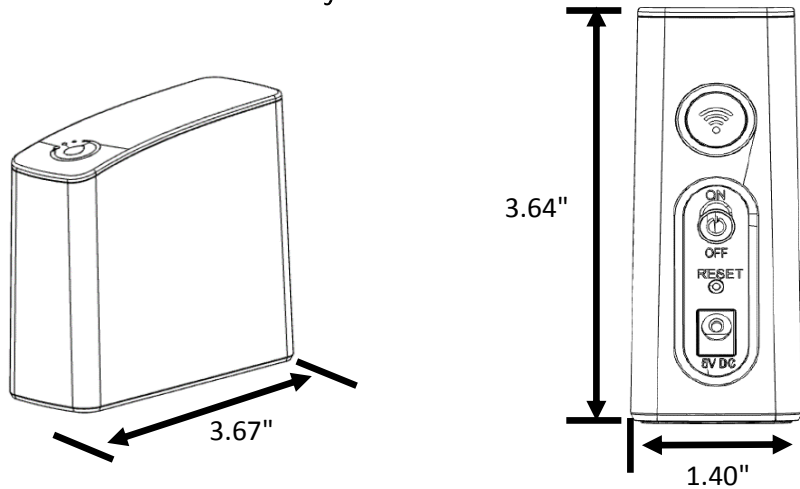

* Dimensions for reference purposes only

Approvals



* 5-year manufacturer's warranty when purchased and installed by a professional installer.