



**Precision Plumbing Products**

*"Specify with Confidence - Install with Pride"*

**PRIME-RITE  
TRAP PRIMER VALVE**

www.pppinc.net

"... Automatically maintains  
**a constant water seal in floor**  
drain traps."

Just the facts:

This innovative trap priming system automatically primes up to two floor drain traps using our patented water distribution system. The PRIME-RITE requires no adjustment but must be installed on a cold water line of 1 1/2" (38mm) diameter or less and must serve a frequently used fixture such as a urinal or a water closet. The priming valve is automatically activated when it senses a pressure drop of 10 PSIG (70 kpa). The valve's operating range is 20 to 80 PSIG (138 to 552 kpa).

**PRIME-RITE TRAP PRIMING VALVE SPECIFICATIONS:**

PPP Model #PR-500 is machined from C69300 ECO corrosion resistant brass.

PPP Model # PR-500 AUS is machined from C69300 ECO DZR corrosion resistant brass.

PPP Model #PR-500AUS approved to Australian Standards Lic. #IP92.

This priming valve contains: No springs, diaphragms, or plastic parts.

**NO Adjustment Required!**

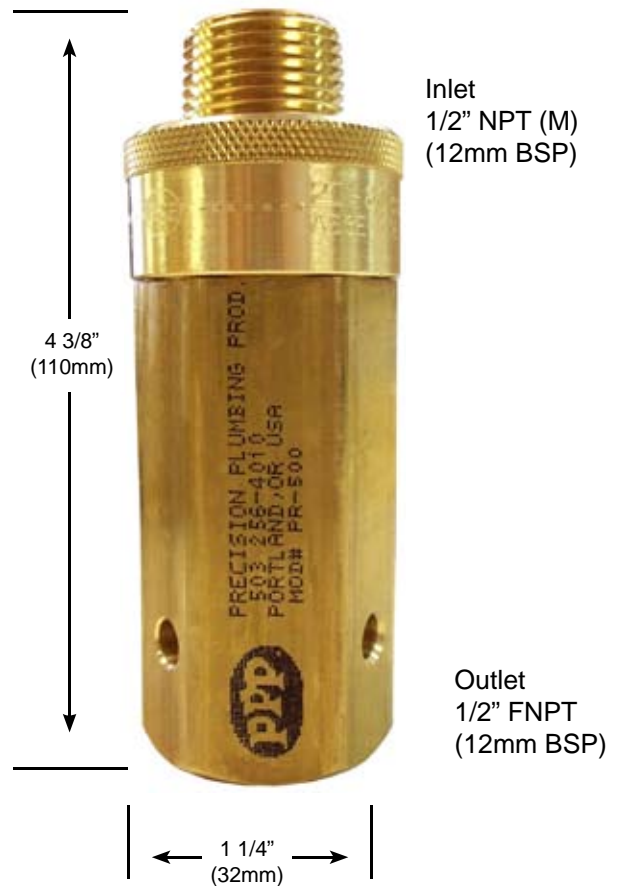

**PART NO: PR-500/PR-500AUS**

**PROJECT SUBMITTAL**

Project: \_\_\_\_\_

Contractor: \_\_\_\_\_

Engineer: \_\_\_\_\_

Date Submitted: \_\_\_\_\_

Prepared By: \_\_\_\_\_

PATENT NO. 4,497,337



TRAP PRIMER DISTRIBUTION UNITS

DISTRIBUTION UNIT DU-4 & DU-U.

A metered amount of water from the floor drain trap primer is distributed to as many as two (2) floor drain traps by means of the patented distribution unit. The priming valve must have a minimum elevation of 12" inches (305mm) above the finished floor.

DISTRIBUTION UNIT INSTALLATION:

- Must be installed level.
- Must be installed with clear plastic cover.
- Must be installed with access for periodic inspection.
- Do not subject trap primer valve to rough-in pressure test.
- For further detail see information sheet specific for the distribution units.

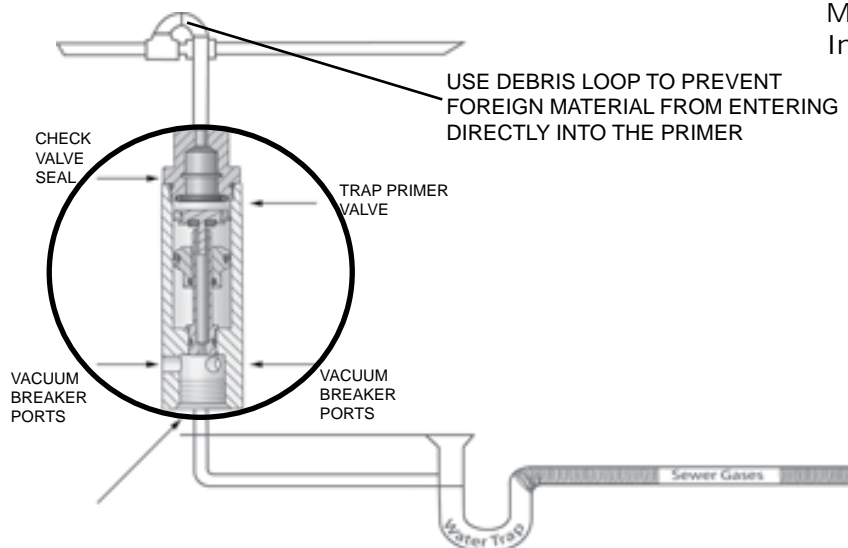
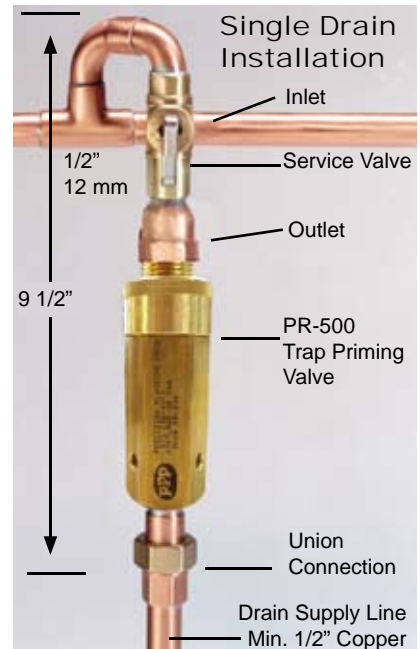

THE PRIMING VALVE MUST HAVE A MINIMUM ELEVATION OF 12 INCHES (305MM) ABOVE THE FINISHED FLOOR

NOTE: Consult plumbing inspector prior to installing distribution units.

Multiple Drain Installation

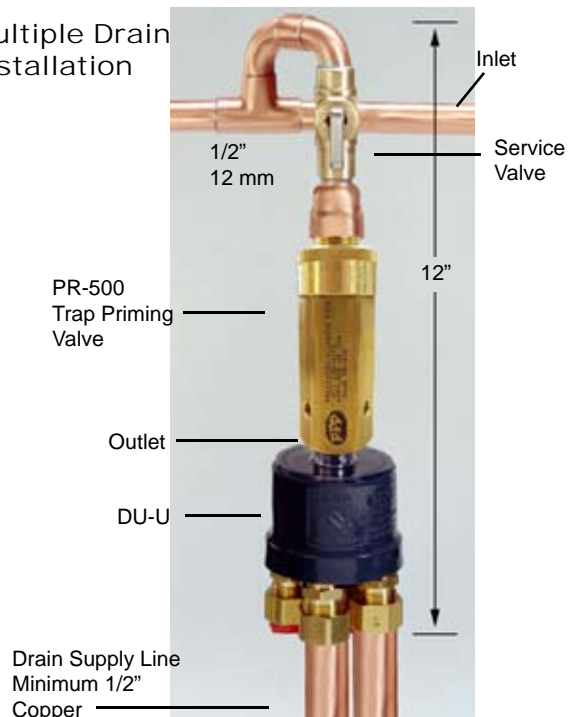

Precision Plumbing Products  
Division of JL Industries, Inc.

Airport Business Center  
6807 NE 79th Court, Suite E  
Portland, Oregon 97218

T (503) 256-4010  
F (503) 253-8165

www.pppinc.net